

B. F. OSBORN.

Plow Coupling.

No. 106,864.

Patented Oct. 30, 1870.

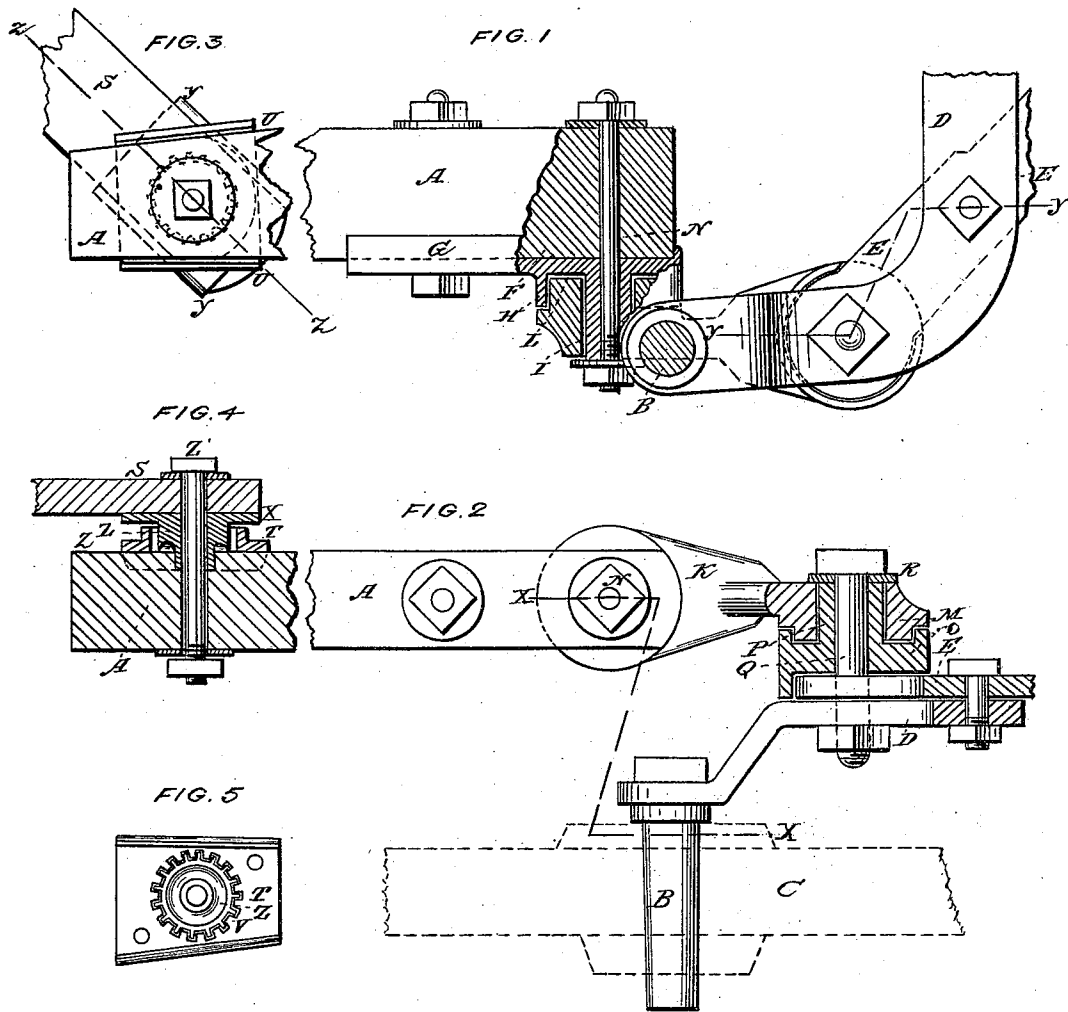

WITNESSES:

*Gustave Dietrich*  
*S. S. Makee*

INVENTOR:

*B. F. Osborn*  
PER *Wm. M. [Signature]*  
attorney

# UNITED STATES PATENT OFFICE.

BENJAMIN F. OSBORN, OF NASHVILLE, TENNESSEE, ASSIGNOR TO T. H. JONES & CO., OF SAME PLACE.

## IMPROVEMENT IN CULTIVATORS.

Specification forming part of Letters Patent No. 106,864, dated August 30, 1870.

*To all whom it may concern:*

Be it known that I, BENJAMIN F. OSBORN, of Nashville, in the county of Davidson and State of Tennessee, have invented a new and useful Improvement in Walking-Cultivators; and I do hereby declare that the following is a full, clear, and exact description thereof, which will enable others skilled in the art to make and use the same, reference being had to the accompanying drawings, forming a part of this specification.

This invention relates to improvements in the construction and arrangement of the joints of the horizontal bars of the frame of cultivators with the axle and the hitching apparatus, to make permanent and durable joints, and to provide for moving the frame vertically and horizontally.

Figure 1 shows a side view, partly sectioned, of part of one of the beams of the frame, also the connection of the same with a part of the apparatus for supporting the short axles and connecting them together, also for hitching the animals. Fig. 2 shows the same partly in plan view and partly in section. Fig. 3 shows in side elevation the manner of connecting the handles to the beams of the frame. Fig. 4 is a section of the same on the line *xx* of Fig. 3, and Fig. 5 is a face view of one of the plates used for connecting the handles.

Similar letters of reference indicate corresponding parts.

The bars A represent parts of the long beams of the frame, running rearward from the wheels, for supporting the cultivator-stocks, also the handle for guiding the machine. The object of the first part of the invention is to connect these bars with the short axles, the hitching apparatus, and the bent bar by which the two axles are bent together, that they may have independent vibration vertically and laterally.

B represents the short axles for the wheels C, on which the front ends of these bars are supported.

D represents parts of the bent bar connecting the two axles.

E represents part of the hitching apparatus.

For connecting the bars A with these parts a metal plate, F, with vertical flanges G rising from the upper edges, and with a circular

flange, H, projecting from the lower side, and a central tubular stud, also projecting from the lower side, is bolted or otherwise fastened to the under side of each beam at the forward end, as shown. Then a joint, K, with a circular horizontal face, L, having an annular groove for the flange H, and a central hole for the stud I at one end, and a circular vertical face, M, having a similar annular groove and circular hole at the other end, is connected to the plate F by a vertical bolt, N, and to the bars D and E by stud O, having a tubular pivot, P, fitting the hole through the vertical face M of the joint K, and confined to the bars D E by a bolt, Q, which also holds the joint A on the stud O by a washer, R. The bars A turn laterally on the horizontal face L of the joint K, and the latter turns vertically on the stud O. The faces of these working parts are made broad and strong, and bear the necessary workings without material wear and without danger of breaking by lateral strain.

For attaching the handles S to the bars A, I employ the plates T, with flanges U lapping the edges of the beam A, with a circular toothed hole, V; also the plates X, with flanges Y lapping the edges of the handles and a central toothed stud, Z, fitting the toothed holes V. These two plates are clamped between the handles and the beam by the bolts Z' passing through the handles, beams, and plates, so as to hold the handles at any required angle. The teeth interlock the plates, so as to hold them from turning. For shifting them to change the pitch of the handles, the bolts are unscrewed, so as to admit of drawing the stud Z out of the hole V.

Having thus described my invention, I claim as new and desire to secure by Letters Patent—

The arrangement, with respect to the beams A A and bars D E of a cultivator, of flanged vertical stud-plates F G H, groove-joint K L M, horizontal stud-plate O P, and bolts N G, to admit of lateral and vertical adjustment, as shown and described.

BENJ. F. OSBORN.

Witnesses:

JO. B. WILLIAMS,  
H. NORVELL.