

(19) World Intellectual Property Organization
International Bureau



(43) International Publication Date
3 June 2011 (03.06.2011)

PCT

(10) International Publication Number
WO 2011/066220 A2

(51) International Patent Classification:
B65D 1/22 (2006.01)

(21) International Application Number:
PCT/US2010/057620

(22) International Filing Date:
22 November 2010 (22.11.2010)

(25) Filing Language: English

(26) Publication Language: English

(30) Priority Data:
61/264,970 30 November 2009 (30.11.2009) US
61/301,734 5 February 2010 (05.02.2010) US

(72) Inventor; and

(71) Applicant : STERN, R., Gabriel [US/US]; P.O. Box 89,
Milltown, NJ 08850-0089 (US).

(74) Agents: BRANCOLINI, John, R. et al.; PEPPER
HAMILTON LLP, 500 Grant Street, 50th Floor, Pitts-
burgh, PA 15219.2502 (US).

(81) Designated States (*unless otherwise indicated, for every
kind of national protection available*): AE, AG, AL, AM,

AO, AT, AU, AZ, BA, BB, BG, BH, BR, BW, BY, BZ,
CA, CH, CL, CN, CO, CR, CU, CZ, DE, DK, DM, DO,
DZ, EC, EE, EG, ES, FI, GB, GD, GE, GH, GM, GT,
HN, HR, HU, ID, IL, IN, IS, JP, KE, KG, KM, KN, KP,
KR, KZ, LA, LC, LK, LR, LS, LT, LU, LY, MA, MD,
ME, MG, MK, MN, MW, MX, MY, MZ, NA, NG, NI,
NO, NZ, OM, PE, PG, PH, PL, PT, RO, RS, RU, SC, SD,
SE, SG, SK, SL, SM, ST, SV, SY, TH, TJ, TM, TN, TR,
TT, TZ, UA, UG, US, UZ, VC, VN, ZA, ZM, ZW.

(84) Designated States (*unless otherwise indicated, for every
kind of regional protection available*): ARIPO (BW, GH,
GM, KE, LR, LS, MW, MZ, NA, SD, SL, SZ, TZ, UG,
ZM, ZW), Eurasian (AM, AZ, BY, KG, KZ, MD, RU, TJ,
TM), European (AL, AT, BE, BG, CH, CY, CZ, DE, DK,
EE, ES, FI, FR, GB, GR, HR, HU, IE, IS, IT, LT, LU,
LV, MC, MK, MT, NL, NO, PL, PT, RO, RS, SE, SI, SK,
SM, TR), OAPI (BF, BJ, CF, CG, CI, CM, GA, GN, GQ,
GW, ML, MR, NE, SN, TD, TG).

Published:

— *without international search report and to be republished
upon receipt of that report (Rule 48.2(g))*



WO 2011/066220 A2

(54) Title: STORAGE CONTAINER SYSTEM INCLUDING UNIVERSAL LIDS

(57) Abstract: A storage system comprising a plurality of storage vessels, wherein each storage vessel has a unique opening diameter such that the storage vessels are adapted to nest within one another, and a plurality of identical lids, wherein each lid is configured to seal each of the storage vessels. Once sealed, the storage vessels are configured to stack and detachably affix on top of one another, providing a convenient way to store the sealed vessels. Each of the identical lids are configured to seal each of the storage vessels such that any combination of storage vessel and lid will result in a tightly sealed storage vessel, lock each of the storage vessels via a locking mechanism, and stack on top of one another via an attachment mechanism such that the identical lids form a compact set of lids that is adapted to be placed onto the compact set of storage vessels.

A. TITLE

STORAGE CONTAINER SYSTEM INCLUDING UNIVERSAL LIDS

B. CROSS REFERENCE TO RELATED APPLICATION

[0001] This application claims the priority benefit of U.S. Provisional Application No. 61/264,970 filed November 30, 2009 and U.S. Provisional Application No. 61/301,734 filed February 5, 2010, the contents of which are both hereby incorporated by reference.

C-E. NOT APPLICABLE

F. BACKGROUND

[0002] The present disclosure relates to a system of storage containers or vessels having a universal lid. More specifically, the present disclosure relates to a system of nested, stackable storage vessels of varied diameters having multiple universal lids, each of which is configured to fit each storage vessel in the system.

[0003] Storage containers have become increasingly popular in recent years. Many people use storage containers to preserve food and/or other items, extending the useable time of many food products. Also, storage containers are used increasingly to transport food between various locations such as from a home to an office, or from a restaurant to a home. Additionally, storage containers are used to store clothing, tools, medication, other household products, and any other item that someone would want to store or preserve.

[0004] Storage containers typically include two components, a lower portion or vessel sized and shaped to hold a certain quantity of an item, and a cover or lid. The vessel and lid are typically constructed from a food grade plastic, providing a lightweight but strong

material. Using plastic also allows for the storage container to be kept in a refrigerator or to be heated in a microwave, thus increasing the functionality of the storage container when used to store food.

[0005] Generally, storage containers are manufactured by various manufacturers and have unique characteristics. For example, each manufacturer may produce a different set of vessels having varying opening diameters, thus resulting in different sized lids for each vessel. As such, each vessel has a unique lid. If this lid is lost or damaged, the vessel is basically useless as a storage container. Similarly, different diameter vessels provides for storage issues when the storage containers themselves need stored. Several vessels may be stacked inside one another, however, the lids must be placed in another location which could result in the lids being lost or misplaced.

G. SUMMARY

[0006] Before the present methods are described, it is to be understood that this invention is not limited to the particular systems, methodologies or protocols described, as these may vary. It is also to be understood that the terminology used herein is for the purpose of describing particular embodiments only, and is not intended to limit the scope of the present disclosure which will be limited only by the appended claims.

[0007] It must be noted that as used herein and in the appended claims, the singular forms “a,” “an,” and “the” include plural reference unless the context clearly dictates otherwise. Thus, for example, reference to a “coil” is a reference to one or more coils and equivalents thereof known to those skilled in the art, and so forth. Unless defined otherwise, all technical and scientific terms used herein have the same meanings as commonly understood by one of ordinary skill in the art. As used herein, the term “comprising” means “including, but not limited to.”

[0008] In one general respect, the embodiments described herein disclose a storage system. The storage system comprises a plurality of storage vessels, wherein each of the plurality of storage vessels has a unique opening diameter such that the plurality of storage vessels are adapted to nest within one another, and a plurality of identical lids, wherein each lid is configured to seal each of the plurality of storage vessels.

[0009] In another general respect, the embodiment disclose a storage system. The storage system comprises a plurality of storage vessels, wherein each of the plurality of storage vessels has a uniquely sized opening such that the plurality of storage vessels are adapted to nest within one another to form a compact set of storage vessels, and a plurality of identical lids. The storage vessels comprise an attachment mechanism such that the bottom of each vessel is configured to stack and detachably affix onto the top of each lid. Each of the plurality of identical lids are configured to seal each of the plurality of storage vessels such that any combination of storage vessel and lid will result in a tightly sealed storage vessel, lock each of the plurality of storage vessels via a locking mechanism, and stack on top of one another via an attachment mechanism when not sealing a vessel such that the plurality of identical lids form a compact set of lids that is adapted to be placed onto the compact set of storage vessels.

H. BRIEF DESCRIPTION OF THE DRAWINGS

[0010] FIG. 1 illustrates an exemplary set of nested storage containers or vessels according to an embodiment.

[0011] FIG. 2A illustrates an exemplary universal lid according to an embodiment.

[0012] FIG. 2B illustrates an exemplary set of stacked universal lids such as the lid shown in FIG. 2A.

[0013] FIG. 3 illustrates an exemplary view of multiple vessels and universal lids according to an embodiment;

[0014] FIG. 4 illustrates an exploded view of a storage system included multiple vessels and universal lids according to an embodiment.

[0015] FIG. 5 illustrates an exemplary view of stacked vessels, each vessel sealed with a universal lid such as the lid shown in FIG. 2A and 2B.

[0016] FIG. 6A illustrates an alternative exemplary universal lid according to an embodiment.

[0017] FIG. 6B illustrates an additional view of the universal lid as shown in FIG. 6A.

[0018] FIG. 7 illustrates a storage system including a set of nested vessels and the universal lid as shown in FIG. 6A.

I. DETAILED DESCRIPTION

[0019] The present invention is directed to a storage system including multiple storage containers or vessels, each vessel having a unique diameter such that the vessels are sized to be nested inside one another. The storage system also includes one or more identical universal lids. The universal lids are configured to tightly seal and lock each vessel in the storage system such that a person utilizing the storage system can conveniently use any of the provided universal lids to seal any of the vessels included in the system. Once sealed, the vessels are configured to stack and detachably affix on top of one another, providing a convenient way to store the sealed vessels. Depending on the intended use, the storage system components may be disposable (e.g., for a take-out food container) or reusable (e.g., for medication storage or long-term food storage).

[0020] FIG. 1 shows an exemplary set **100** of stackable, nested storage vessels. For example, a small vessel **106**, a medium vessel **104** and a large vessel **102** may be included in set **100**. As shown in FIG. 1, medium vessel **104** may be sized such that it fits inside of large vessel **102**. Similarly, small vessel **106** may be sized such that it fits inside of medium vessel **104**; thereby resulting in a compact, nested set **100** of vessels. It should be noted that while round vessels are shown in FIG. 1, they are shown by way of example only. Additional shapes such as square, rectangle, oval and other similarly shaped vessels may be included in a set **100** of vessels.

[0021] Various sizes of vessels may be included in set **100**. For example, the set **100** may include vessels having openings such as:

- .5 inches, 1 inch, 1.5 inches
- 2 inches, 3 inches, 4 inches
- 3 inches, 5 inches, 7 inches
- 5 inches, 6 inches, 8 inches
- 20 inches, 22 inches, 24 inches

It should be noted these opening sizes are shown by way of example only. Similarly, three opening sizes are shown by way of example only, the set **100** may include any number of vessels.

[0022] FIG. 2A illustrates an exemplary universal or multi-fit lid **200**. The lid **200** may include various diameters of attachment rims **202A**, **202B** and **202C**. The various attachment rims **202A**, **202B** and **202C** may be sized depending on the types of vessels to be sealed with the lid **200**. For example, if the lid **200** is intended to seal an exemplary set of vessels having diameters of six inches, eight inches and ten inches, attachment rim **202A** may be sized such that it seals to a six inch diameter vessel, attachment rim **202B** may be sized such that it attaches to an eight inch diameter vessel, and attachment rim **202C** may be sized

such that it attaches to a ten inch diameter vessel. Thus, a set of storage containers may include three or four nestable, stackable vessels having varying diameters.

[0023] The configuration and arrangement of the various attachment rims **202A**, **202B** and **202C** may vary depending on the type of vessel to close. For example, if the vessel uses a friction fit to hold the lid **200** on, the attachment rims may be smooth plastic, slightly contoured toward the center of the lid to provide any necessary friction to hold the lid on the vessel. Each attachment rim may include a locking feature **204**. The locking feature results in the lid **200** locking to the vessel such that the lid is not easily removed via bumping, dropping, knocking over, or other similar disturbances. For example, the locking feature **204** may be a bayonet fitting. A bayonet fitting or coupling includes a pin or similar protrusion on one component (i.e., the lid) and an L-shaped slot or groove in a second component (i.e., the vessel). The pin enters the slot and locks via a twisting motion. A spring or detent may be included in the slot that locks the pin into the slot, thereby requiring additional force or a twisting motion to separate the two components. By incorporating a bayonet fitting, the lid and vessel may be tightly locked, thereby forming a watertight seal. Alternatively, if the vessel opening is threaded and uses a screw-on lid **200**, the attachment rims **202A**, **202B** and **202C** of the lid may include locking threads such that the lid may be screwed onto the individual vessels. Similarly, a push to release locking feature **204** may be included in the lid similar to a child-proof locking feature on a medication bottle. Additional configurations may be used for the attachment rims **202A**, **202B** and **202C** as well such as a varying diameter attachment rim where by twisting the lid **200** the diameter of the attachment rim changes slightly, thus providing a more universal size for the lid. It should be noted that these types of attachment rims are shown by way of example only, and any other suitable method for configuring the attachment rims may be incorporated.

[0024] Once locked, the lid **200** may provide a watertight seal with the vessel thereby preventing any spilling or leaking from the vessel if the sealed vessel is shaken, knocked over, dropped, or similarly disturbed.

[0025] The lid **200** may have various shapes depending on the intended application. As shown in FIG. 2, the lid **200** has a semi-collapsed dome shape. The lid **200** may also be flat, having each of the fasteners on a single plane. Alternatively, the lid **200** may be shaped similarly to a cone or funnel, providing smooth sides angled between each of the fasteners. Another alternative may be a pyramid shape or a stepped pyramid, wherein each of the varying diameters of fasteners steps in like sections of cylinders having decreasing diameters. It should be noted that the shape and geometry of the lid **200** may be determined based upon the intended application and what shape vessels are being utilized. For example, if the set of storage vessels is rectangular or square in shape, lid **200** may be shaped accordingly to accommodate the vessels.

[0026] The lid may also have a grip and/or handle **206** that allows a user's hand to have a better grip to open and/or close the lid. For example, a small protrusion may encircle the outside edge of the lid **200**, thereby providing additional space to grip. The grip **206** may also include an inward depression on the top surface of the lid **200**, thereby allowing a user's fingers to grab the lid with additional force. The grip **206** may also include an outward protrusion on the top surface of the lid **200**, thereby allowing a user's fingers to grab the lid with additional force.

[0027] The grip **206** may also include an ergonomically designed portion that includes a combination of protrusions and/or depressions allowing for a grip shaped to a user's hand. The ergonomic grip **206** may allow for the user to comfortably grip the lid **200** and apply a strong leveraging effect on the lid, thereby providing a person with lesser

physical strength (e.g., a child, elderly person and/or a physically disabled person) to apply the necessary force to twist, lift or otherwise unlock and remove a sealed lid from a vessel.

[0028] The lid **200** may further include an attachment point **208** for connecting to various other lids **200**. For example, a small tab and indentation **208** may be included on the top and/or bottom of the lid **200** such that when another lid is placed on top of the lid, the tab from one lid snaps into the indentation on another lid. Alternative types of fasteners **208** may be used to hold the interconnected lids together such as a small ring indentation on the top of a first lid, and a small attachment rim on the bottom of a second lid positioned such that when the second lid is placed on top of the first lid, the attachment rim locks into the small ring indentation. It should be noted that these interconnection means are shown by way of example only and other similar methods of interconnecting the lids may be used.

[0029] An equal number of identical lids **200** may be included based upon the number of vessels included in a storage set. For example, set **100** as shown in FIG. 1 may be sold with three lids **200**, one for each vessel in the set. As shown in FIG. 2B, the three lids **200** may be configured such that they stack on top of one another, locking together via the attachment point **208** on each lid.

[0030] FIG. 3 illustrates various components of a storage system including a set of multiple vessels **102**, **104** and **106** as well as multiple, identical lids **200**. It should be noted that only two lids are shown in FIG. 3 for convenience of illustrations. A storage system such as the one shown in FIG. 3 would include an equal number of lids and vessels. Various advantages of such a set of vessels and lids include easy of use, ease of replacement for any damaged or lost components, aid to physically challenged people (e.g., a blind or otherwise visually impaired person would not need to try multiple lids to find an appropriate lid as each lid fits each vessel), and other similar advantages that may be realized.

[0031] It should be noted that vessel **106** is shown as transparent in FIG. 3 by way of example only and shows an exemplary impression in the bottom of vessel **106** that is configured to fit the attachment point **208** on lid **200** when stacking sealed vessels (e.g., see FIG. 5 and the accompanying description below). It should also be noted the shape of the impression on the bottom of the vessel **106** may vary. For example, the impression may be a circle, oval, square, or any other shape configured and sized to fit the attachment point **208** on lid **200**. Additionally, the bottom of the vessel **106** may be thickened around the impression such that the inside bottom surface of the vessel is smooth and flat allowing for easy cleaning of the vessel. A similar impression may be included on each vessel (e.g., vessels **102**, **104** and **106**) in the storage system.

[0032] The attachment rims **202A**, **202B** and **202C** of lids **200** may be configured such that they fit vessels **102**, **104** and **106** respectively. Once the vessels are stacked and nested, a lid **200** may attach to the largest, outside vessel such that all the nested, stacked vessels are covered. The remaining lids **200** may connect to the attached lid, thus resulting in a single, compact, connected set of storage containers. FIG. 4 illustrates an exploded view of such a storage system. The nested, stacked vessels **102**, **104** and **106** are shown along with included lids **200**.

[0033] As shown in FIG. 5, the components of the storage system may be arranged in a stacked configuration. For example, when a first lid **200** is placed on the large vessel **102**, and a second lid is placed on the medium vessel **104**, the sealed medium vessel may be stacked on top of the sealed large vessel. An impression or similar locking feature on the bottom of the medium vessel **104** (e.g., similar to the impression shown on vessel **106** in FIG. 3) may detachably affix or attach onto a protrusion on the lid **200** of the large vessel, thereby providing for a set of stacked storage containers. Similarly, a third lid **200** may be used to seal the small vessel **106**, and the sealed small vessel may be stacked on top of the sealed

medium vessel. It should be noted the vessels are shown stacked small-medium-large by way of example only. The universal features of both the lid **200** provides for alternative stacking patterns. For example, a sealed small vessel **106** may be placed on the sealed large vessel **102**. Similarly, if a person has multiple sets **100** of vessels and lids **200**, a sealed medium vessel **104** may be placed directly on top of another sealed medium vessel **104**. When not all being used, the storage vessels may be nested inside one another and the lids may be stacked on top of the nested storage vessels for convenient, organized storage.

[0034] Once sealed, each vessel may be further wrapped or otherwise manufactured to be tamper proof. For example, a restaurant may use the present invention to provide for a set of to go containers having various sized vessels using a single lid. Once the food is placed in the vessel and sealed with the lid, the vessel may be wrapped or a paper seal may be placed on the vessel to prevent tampering.

[0035] FIGS. 6A, 6B and 7 illustrate the nested, stacked arrangement of storage vessels as discussed above with an alternative design for a universal lid. As shown in FIGS. 6A and 6B, a ridged design may be incorporated in the construction of a lid **600**. FIGS. 6A and 6B illustrate various views of the lid **600**. The lid **600** may be constructed with various ridges that form a combination of peaks and valleys **602**. The valleys **602** may be sized and shaped such that each valley is spaced to accept various sized vessels. The spacing of the valleys **602** may alternate on each side of the lid **600**. For example, as shown in the right image of FIG. 6A, the valleys **602** may alternate between the left side of the lid **600** (as positioned in FIG. 6A) and the right side of the lid. Each individual valley **602** on a side may be spaced by a constant amount, for example, .5 inches. However, by staggering the valleys **602** on each side of the lid **600**, the actual spacing between all valleys on the lid, in this example, would be .25 inches. This provides the lid **600** with twice as many potential vessels

it may seal and close in the same size as a lid only having valleys (or spaced ridges or edges) on a single side.

[0036] As shown in FIG. 7, the ridged, or “zig-zag” lid **600** may be used with a similar set of nested, stacked vessels as discussed before. Like above, the small vessel **106** may be placed inside the medium vessel **104**, which is in turn placed inside the large vessel **102**. Multiple lids **600** may be provided (e.g., equal in number to the amount of vessels included in the set). However, due to its universal nature, the lid **600** may be purchased or acquired separately from a set of vessels and still function to close the various vessels in the set.

[0037] If included in a set, the lid **600** may include various color coded peaks or valleys **602** that correspond to a color coded storage vessel. For example, if the small vessel **106** has a 6 inch opening, it may be colored green. The corresponding 6 inch diameter valley **602** on the lid **600** may also be colored green. Similarly, the medium vessel **104** and its corresponding valley **602** may be colored red, and the large vessel **102**, and its corresponding valley **602** may be colored blue. The color coding may be used as a simple means to aid a user of the lid **600** quickly determine which side of the lid is to be used with a certain vessel. In the event the lid **600** is purchased separately from a set of storage vessels, each of the valleys **602** of the lid may be a unique color corresponding to a certain diameter opening. The center, flat portion of the lid **600** may include a legend listing the various diameters of the valleys **602** as well as the corresponding color for easy reference. It should be noted that the colors discussed herein are provided by way of example only and are not meant to limit the invention.

[0038] Similar to the lid **200**, the lid **600** may include a small protrusion encircling an outside edge of the lid, thereby providing additional space to grip. The grip may also include an inward depression on the top surface of the lid **600**, thereby allowing a user's

fingers to grab the lid with additional force. The grip may also include an outward protrusion on the top surface of the lid **600**, thereby allowing a user's fingers to grab the lid with additional force. Additionally, the lid **600** may further include an attachment point for connecting to various other lids. For example, a small tab and indentation may be included on the top and/or bottom of the lid **600** such that when another lid is placed on top of the lid, the tab from one lid snaps into the indentation on another lid.

[0039] The lid **600** may be configured to include various features in the individual valleys **602** to improve closing, sealing and locking characteristics of the lid. For example, if a storage container or vessel uses a friction fit to hold the lid **600** on, the valleys **602** may be smooth plastic, slightly contoured toward the center of the lid to provide any necessary friction to hold the lid on the vessel. Alternatively, if the vessel opening is threaded and uses a screw-on lid, the valleys **602** of the lid **600** may include threads such that the lid may be screwed onto the individual vessel. Alternatively, various protrusions may be included in the valleys **602** such that additional surface area is provided for creating additional friction when the lid **600** is placed on a particular vessel. For example, as shown in FIG. 6B, various patterns of small protrusions may be included on the inner surfaces of the peaks and valleys **602**, resulting in the additional surface area for gripping a vessel. Similarly, a circular ringed ridge may be included in each valley **602** to provide a pressure-push and snap fit on a vessel. It should be noted that these types of attachment rims are shown by way of example only, and any other suitable method for configuring the peaks and valleys **602** may be incorporated.

[0040] Similar to the lid **200**, the lid **600** may have various shapes depending on the intended application. As shown in FIGS. 6A, 6B and 7, the lid **600** has circular shape, having each of the valleys **602** on a single plane, alternating between a first and second side of the lid. Alternatively, the lid **600** may be shaped similarly to a cone or funnel, providing smooth sides angled between each of the valleys **602**. It should be noted that the shape and geometry

of the lid **600** may be determined based upon the intended application and what shape vessels are being utilized. For example, if the set of storage vessels is rectangular or square in shape, lid **600** may be shaped accordingly to accommodate the vessels.

[0041] Due to its intended function, the lid **600** may be constructed from a material that provides both rigidity as well as flexibility. For example, various plastics and polymers may be used in the construction of the lid **600**. If the lid **600** is included in a set of storage vessels, the lid may be constructed from a similar material as the storage vessels to provide color and texture consistency. Alternatively, the lid **600** may be constructed from a different material than the storage vessels to increase the friction created between the lid **600** and the individual storage vessels when the vessel is sealed.

[0042] It should be noted that the above discussed storage systems may be modified in various ways to achieve additional convenience features. For example, the attachment points and valleys of the universal lids may be sized such that a brush can be inserted for easy cleaning of the lids. Similarly, the attachment points and valleys may include a thin piece of flexible rubber or plastic to provide additional sealing and waterproofing.

[0043] It will be appreciated that several of the above-disclosed and other features and functions, or alternatives thereof, may be desirably combined into many other different systems or applications. For example, multiple sets of storage containers may be stacked and detachably locked on top of one another via a set of depressions/impressions on the top of the lids and the bottom of the vessels as discussed above, thereby resulting in a larger, more versatile set of storage containers above and beyond those illustrated herein. The examples provided herein have been limited in number for convenience of explanation and illustration; however it should be noted the examples shown herein are not meant to limit the invention.

J. CLAIMS

What is claimed is:

1. A storage system comprising:
a plurality of storage vessels, wherein each of the plurality of storage vessels has a unique opening diameter such that the plurality of storage vessels are adapted to nest within one another; and
a plurality of identical lids, wherein each lid is configured to seal each of the plurality of storage vessels.
2. The system of claim 1, wherein each of the plurality of lids further comprises a set of attachment rims positioned such that the attachment rims coincide with each unique opening diameter of the plurality of storage vessels.
3. The system of claim 1, wherein each of the plurality of lids further comprises a locking mechanism.
4. The system of claim 3, wherein the locking mechanism comprises at least one of a bayonet fitting, a screw-thread, and a push-to-release mechanism.
5. The system of claim 1, wherein each of the plurality of lids further comprises an ergonomically designed portion.
6. The system of claim 1, wherein each of the plurality of lids further comprises an attachment mechanism such that a first lid may be stacked and locked onto a second lid.

7. The system of claim 6, wherein each of the storage vessels comprises a similar attachment mechanism to that of the lids such that the bottom of each vessel is configured to stack and lock onto the top of each lid.
8. The system of claim 1, wherein each of the lids comprises a zig-zag design defining a plurality of peaks and valleys.
9. The system of claim 8, wherein each of the lids further comprises a locking mechanism.
10. The system of claim 8, wherein each of the plurality of valleys is uniquely color coded to identify the size of a particular valley.
11. A storage system comprising:
 - a plurality of storage vessels, wherein each of the plurality of storage vessels has a uniquely sized opening such that the plurality of storage vessels are adapted to nest within one another to form a compact set of storage vessels; and
 - a plurality of identical lids, wherein each lid is configured to:
 - seal each of the plurality of storage vessels such that any combination of storage vessel and lid will result in a tightly sealed storage vessel,
 - lock each of the plurality of storage vessels via a locking mechanism; and
 - stack on top of one another via an attachment mechanism when not sealing a vessel such that the plurality of identical lids form a compact set of lids that is adapted to be placed onto the compact set of storage vessels.

12. The system of claim 11, wherein each of the plurality of lids further comprises a set of attachment rims positioned such that the attachment rims coincide with each uniquely sized opening of the plurality of storage vessels.
13. The system of claim 11, wherein the locking mechanism comprises at least one of the following:
 - a bayonet fitting;
 - a screw-thread;
 - and a push-to-release mechanism.
14. The system of claim 11, wherein each of the plurality of lids further comprises an ergonomically designed portion.
15. The system of claim 11, wherein each of the storage vessels comprises a similar attachment mechanism to that of the lids such that the bottom of each vessel is configured to stack and detachably affix onto the top of each lid.
16. The system of claim 11, wherein each of the lids comprises a zig-zag design defining a plurality of peaks and valleys.
17. The system of claim 16, wherein each of the lids further comprises a locking mechanism.
18. The system of claim 16, wherein each of the plurality of valleys is uniquely color coded to identify the size of a particular valley.

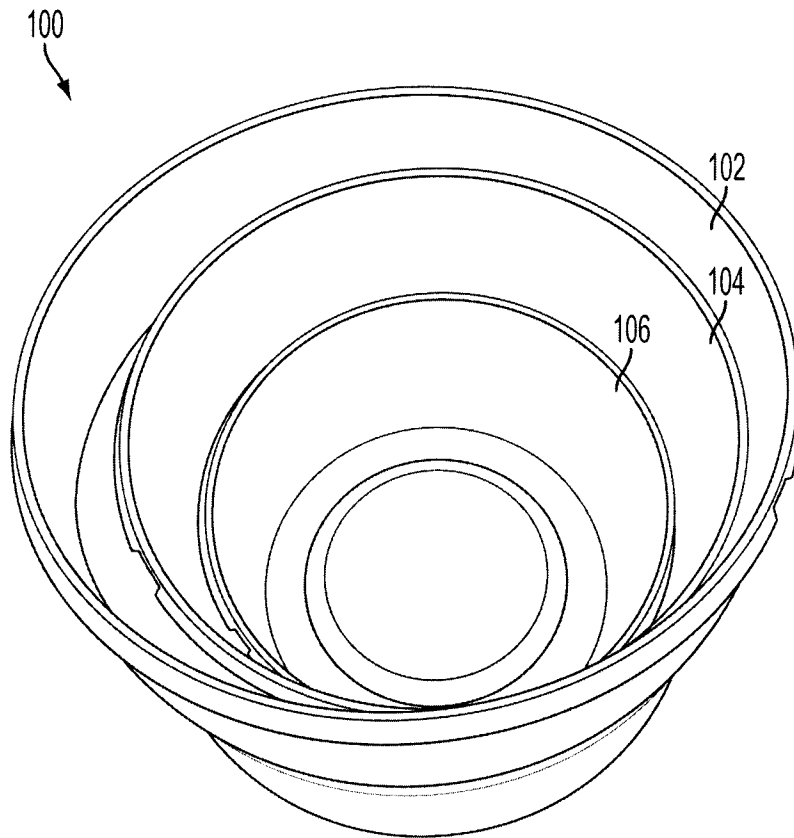

FIG. 1

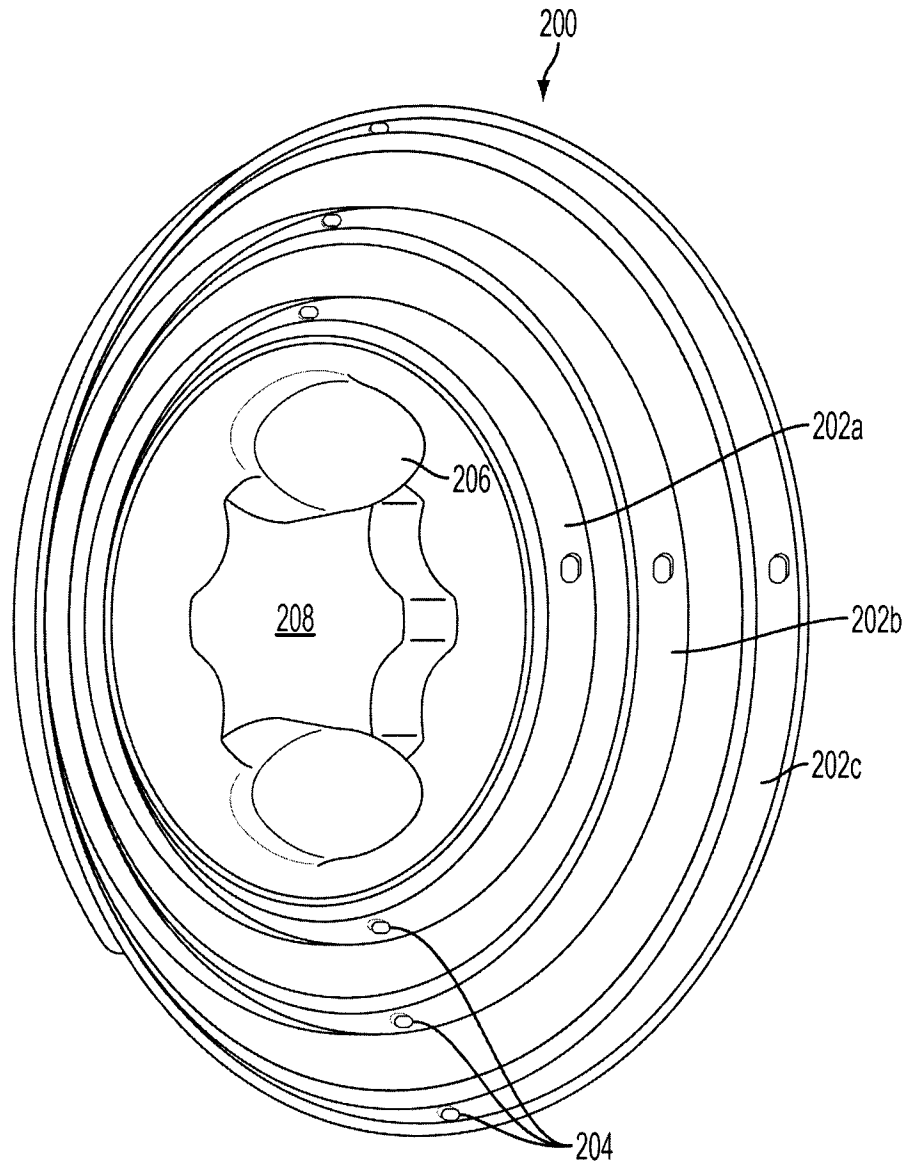

FIG. 2A

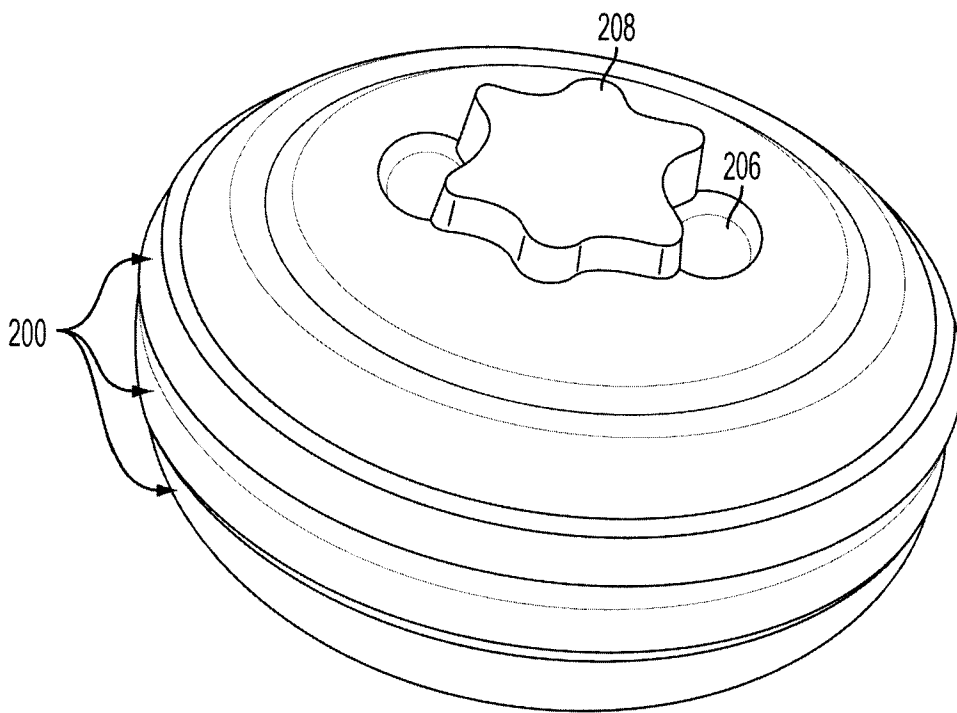

FIG. 2B

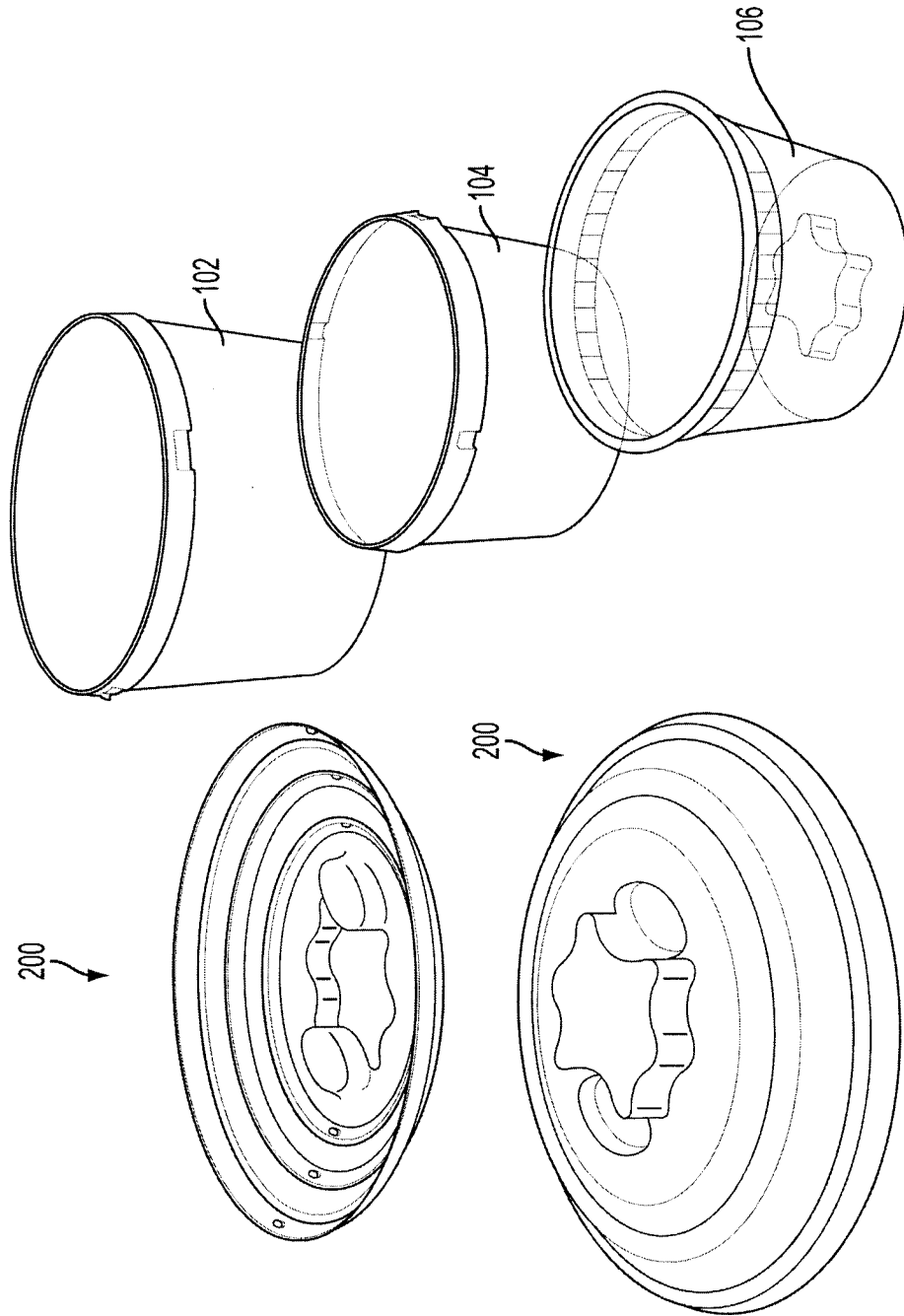

FIG. 3

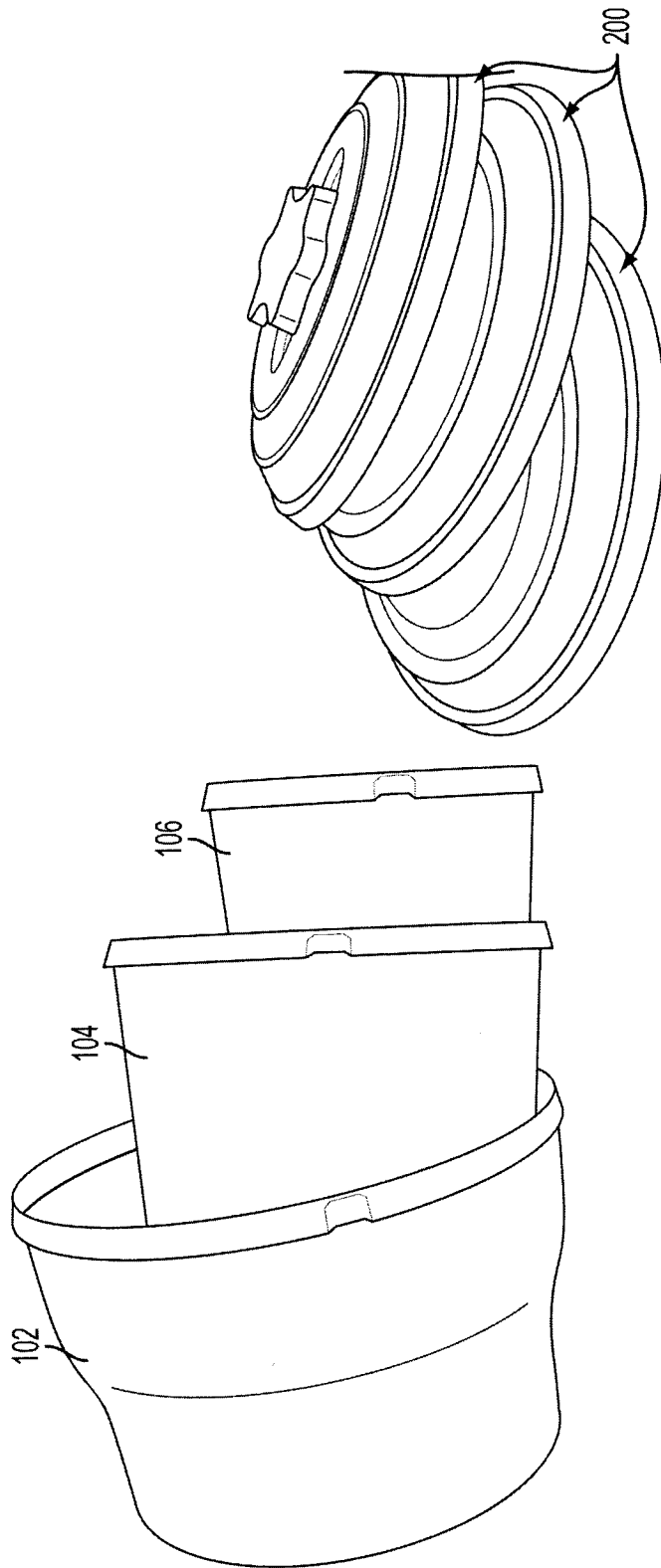

FIG. 4

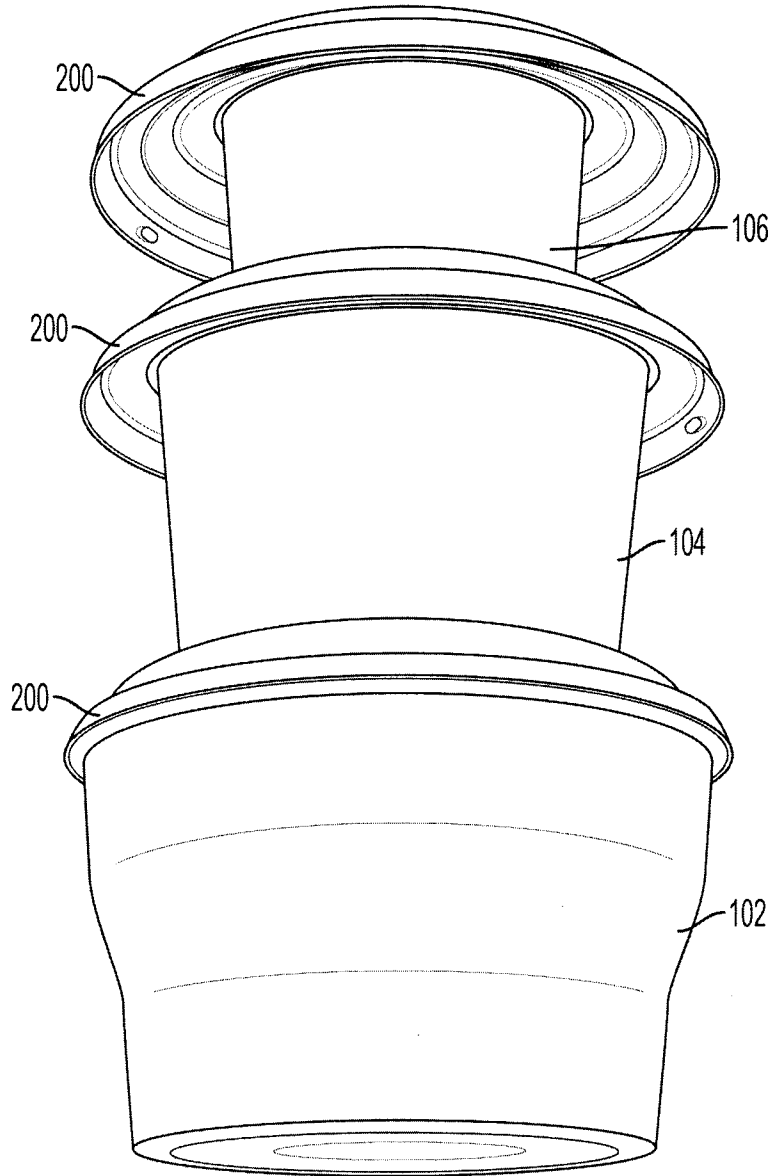

FIG. 5

7/9

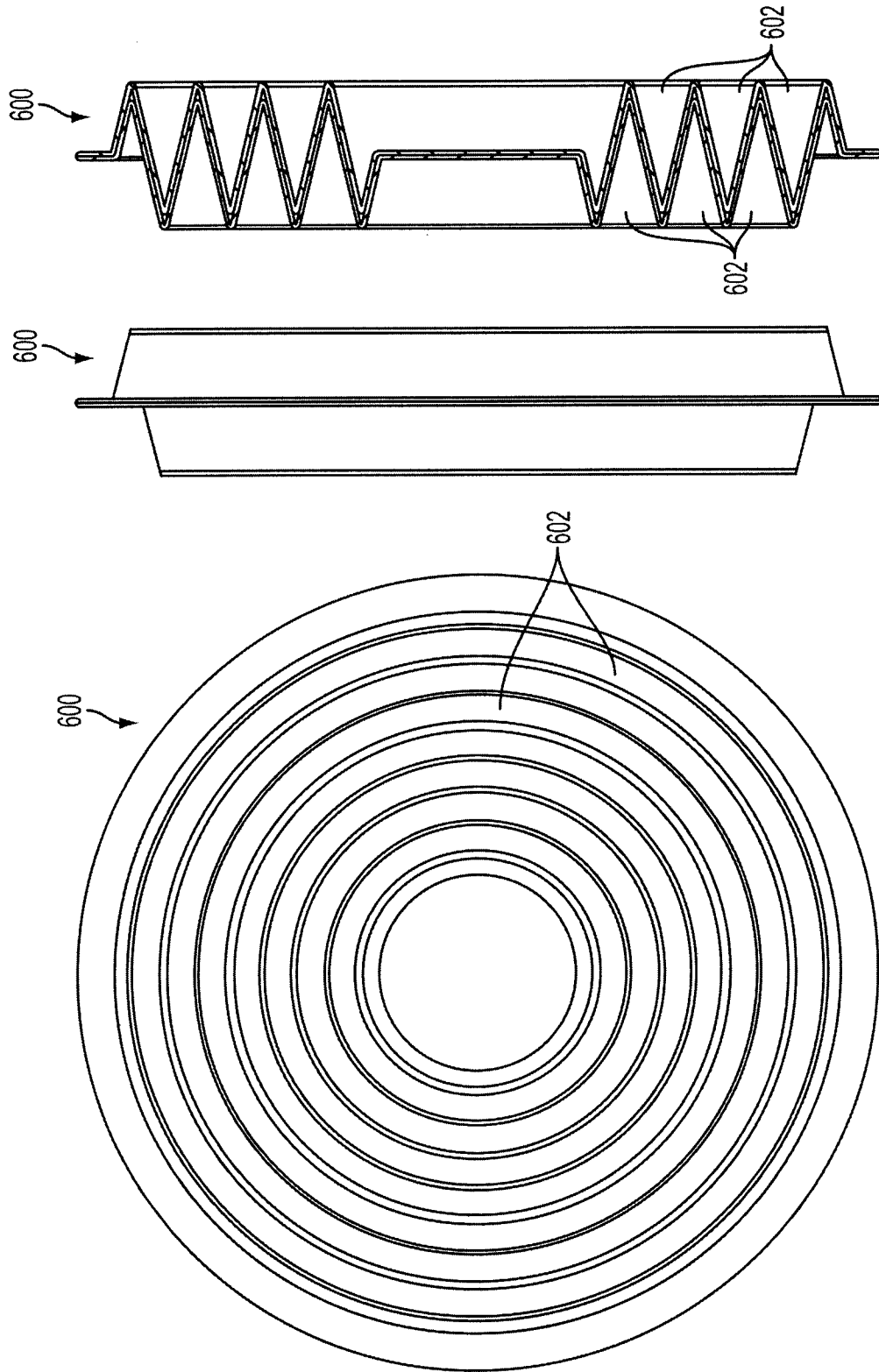

FIG. 6A

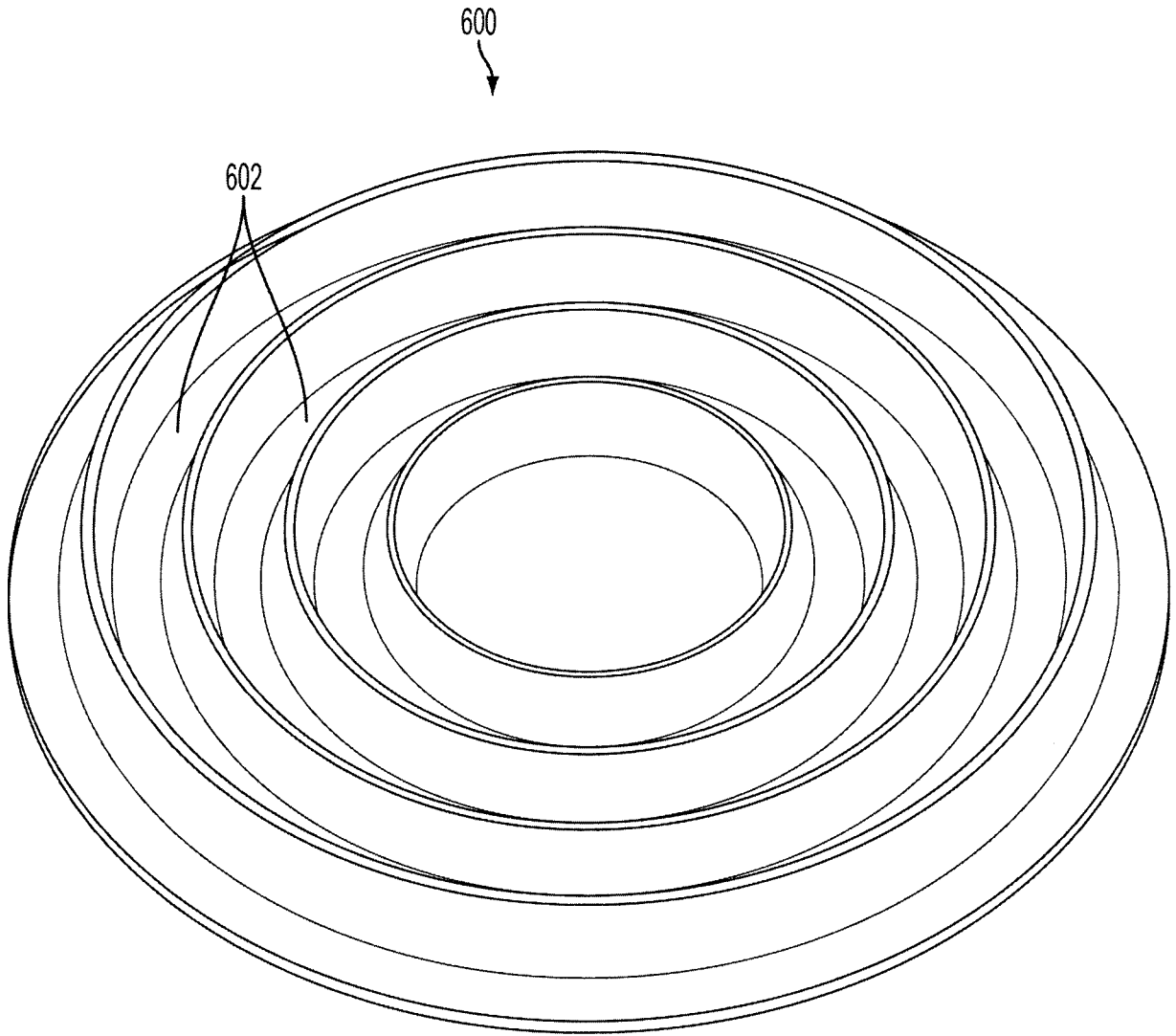

FIG. 6B

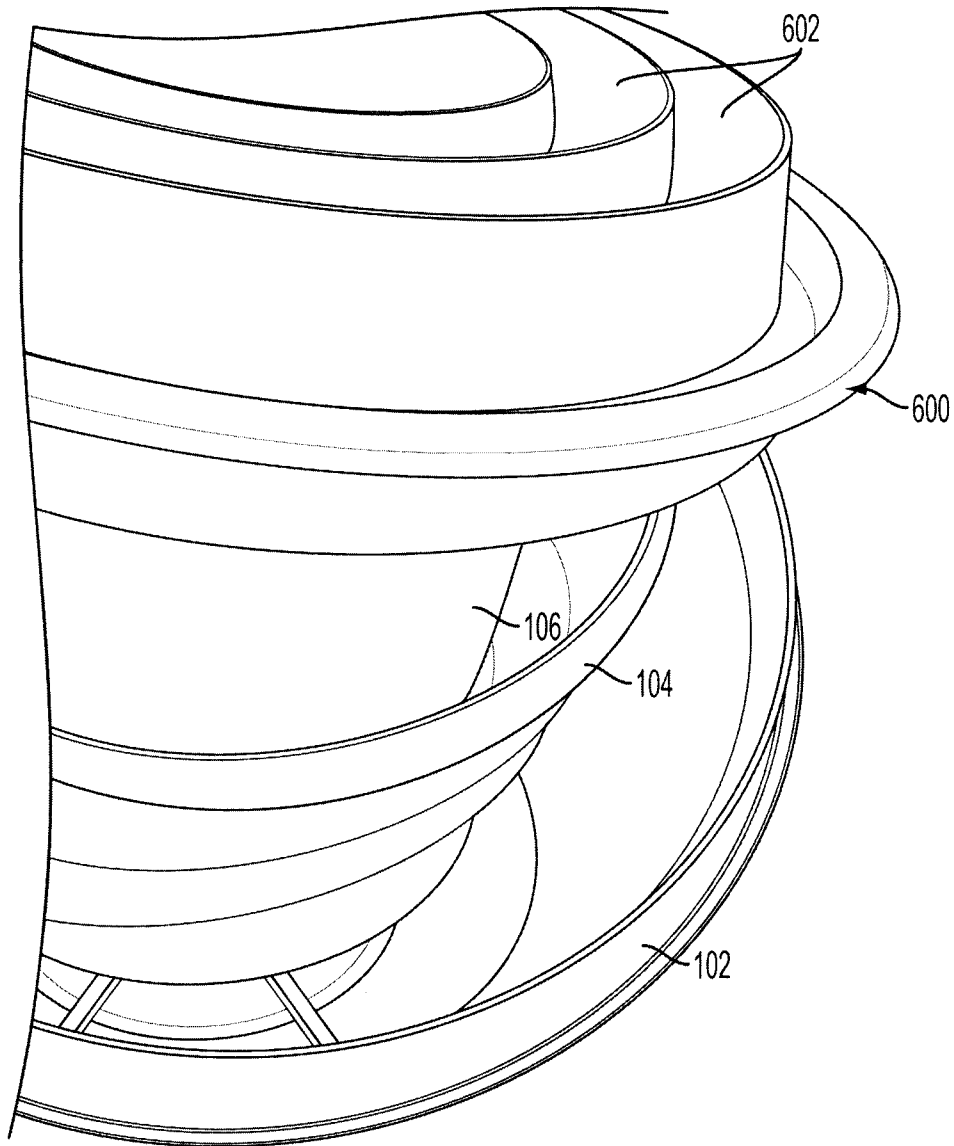

FIG. 7