

A. RYDEN.
TOOL FOR PLANERS OR SHAPERS.

APPLICATION FILED FEB. 24, 1903.

NO MODEL.

Fig. 1.

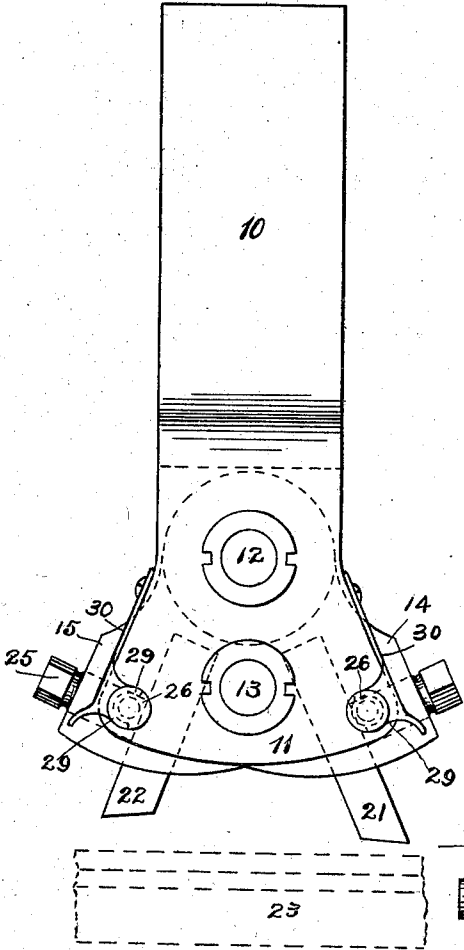

Fig. 2.

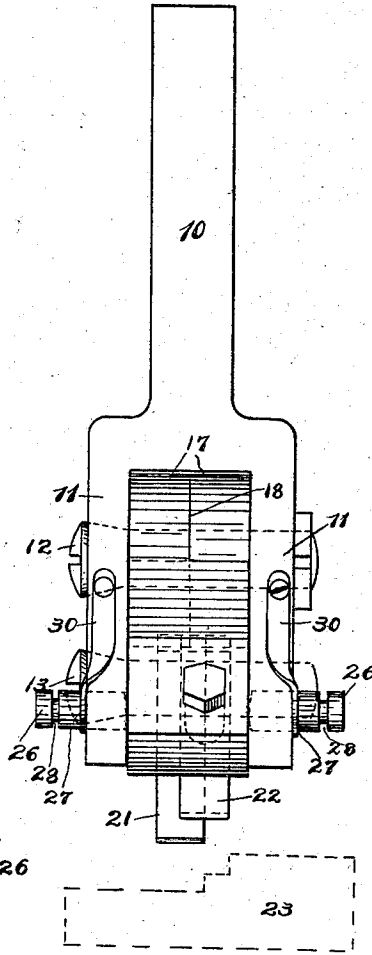

Fig. 5.

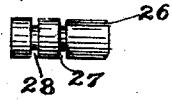

Fig. 3.

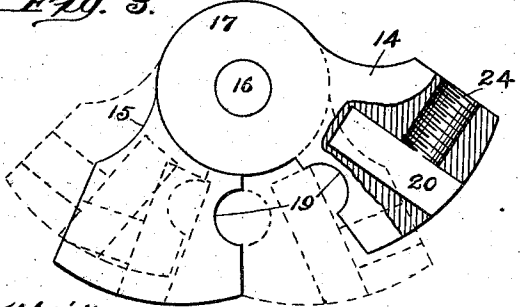
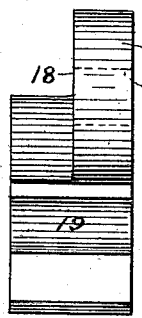

Fig. 4.



Witnesses:

Chas. E. Gorton.
A. Gustafson

Inventor.

Axel Ryden
By Chas. Tillman *ATTY.*

UNITED STATES PATENT OFFICE.

AXEL RYDEN, OF CHICAGO, ILLINOIS, ASSIGNOR OF TWO-THIRDS TO OTTO PRICE, OF CHICAGO, ILLINOIS.

TOOL FOR PLANERS OR SHAPERS.

SPECIFICATION forming part of Letters Patent No. 731,388, dated June 16, 1903.

Application filed February 24, 1903. Serial No. 144,568. (No model.)

To all whom it may concern:

Be it known that I, AXEL RYDEN, a citizen of the United States, residing at Chicago, in the county of Cook and State of Illinois, have invented certain new and useful Improvements in Tools for Planers or Shapers, of which the following is a specification.

This invention relates to improvements in a tool to be used on planers or shapers for planing or cutting material; and it consists in certain peculiarities of the construction, novel arrangement, and operation of the parts thereof, as will be hereinafter more fully set forth and specifically claimed.

The principal object of the invention is to provide a device of the above-named character which shall be simple and inexpensive in construction and so made that it will cut the material both in its forward and rearward movements—in other words, to provide a tool for a planer or shaper which shall give to the material a rough cut in its forward movement and a finishing cut in its rearward movement.

In order to enable others skilled in the art to which my invention pertains to make and use the same, I will now proceed to describe it, referring to the accompanying drawings, in which—

Figure 1 is a face view in elevation of a tool embodying my invention. Fig. 2 is a side view thereof. Fig. 3 is a face view, partly in section and partly in elevation, of the bit-carrying members detached from the frame, but showing the bits removed and illustrating some of the positions which said members may assume. Fig. 4 is an edge view of one of the bit-carrying members, and Fig. 5 is a detached perspective view of one of the locking-pins for holding the members in a raised position.

Like numerals of reference refer to corresponding parts throughout the different views of the drawings.

The frame of the tool comprises a bar or shank 10 to fit in a suitable opening in the tool-carrying head of a planer or shaper (not shown) and has its lower portion bifurcated or formed with prongs 11, between which the bit-carrying members are located. The forks or prongs 11 of the frame are provided with suitable openings, in which are located bolts

12 and 13, on the upper one of which are pivotally secured the bit-carrying members 14 and 15, the upper portion of each of which is formed circular and provided with an opening 16 to receive the bolt 12, which, as before stated, is located in the upper portion of the prongs of the frame. These members are counterparts of one another, and, as shown in Fig. 4 of the drawings, each has its upper circular portion 17 cut away to form a recess 18 to receive the upper circular portion of the other member. Their meeting edges are formed with transverse circular recesses 19 to receive the bolt 13, which is employed to brace each of the members when in the operation of cutting. Extending upwardly from the lower surface of each of the members 14 and 15 is an opening 20 to receive the bits 21 and 22, which may be of the ordinary or any preferred construction.

As shown in Fig. 2 of the drawings, the bits are arranged out of alinement with one another, so that the cut (in the material 23, shown by dotted lines in Figs. 1 and 2) made by the advancing or rough-cutting bit will be in advance of the cut made by the finished-cutting bit. Each of the members 14 and 15 is provided on its outer side with a screw-threaded opening 24, which communicates with the opening 20, as shown in Fig. 3 of the drawings. Located in each of the openings 24 is a set-screw 25, used for securing the bits in place. Located in a suitable opening in the lower portion of one of the prongs 11 and near each of its lower corners is a locking or catch pin 26, which is provided with two annular recesses 27 and 28 to receive the arms 29 of a spring 30, which is secured to the edges of the prong 11, on which the pins 26 are located. These pins are normally held out of engagement with the members 14 and 15 by means of the springs 30, the arms 29 of which embrace the pins in their inner recesses 27; but when it is desired to hold one of the members in a raised position or to prevent its bit cutting the arms of the springs 30 are withdrawn from the recess 27, when the pin may be passed farther into the opening therefor, so as to project beyond the inner surface of the prong 11, in which it is located, so as to engage the inner or meeting edge of

the bit-carrying member. When thus arranged, the arms of the spring are permitted to engage the recesses 28 of the pin, thus holding it securely in its inwardly-projected position.

5 Having thus fully described my invention, what I claim as new, and desire to secure by Letters Patent, is—

1. In a tool for planers and the like, the combination with a bifurcated frame, of two bolts transversely located in its prongs, two bit-carrying members each having its upper portion rounded and cut away to form a recess to receive the rounded upper portion of the other and pivotally secured on the upper bolt between the forks of the frame, each of said members having in its meeting edge a recess to receive the lower bolt, and a bit adjustably secured in the lower portion of each of said members, substantially as described.

2. In a tool for planers and the like, the combination with a bifurcated frame, of two bolts transversely located one above the other in the forks of the frame, two bit-carrying members overlapping each other at their upper portions and pivotally secured on the upper bolt, a bit adjustably secured in the lower portion of each of said members, a locking or catch pin located in an opening therefor at each lower corner of one of the prongs, each of said pins having two recesses therein and a spring secured near each edge of the prong on which the pins are mounted, and having arms to embrace the pins in their recesses, substantially as described.

AXEL RYDEN.

Witnesses:

CHAS. C. TILLMAN,
A. GUSTAFSON.