

(19) World Intellectual Property Organization  
International Bureau



(43) International Publication Date  
26 May 2011 (26.05.2011)

(10) International Publication Number  
**WO 2011/061686 A1**

- (51) **International Patent Classification:**  
*B24B 31/06* (2006.01)      *B23Q 3/152* (2006.01)
- (21) **International Application Number:**  
PCT/IB2010/055210
- (22) **International Filing Date:**  
17 November 2010 (17.11.2010)
- (25) **Filing Language:** English
- (26) **Publication Language:** English
- (30) **Priority Data:**  
12/620,140 17 November 2009 (17.11.2009) US  
61/264,114 24 November 2009 (24.11.2009) US
- (71) **Applicant (for all designated States except US):** REM TECHNOLOGIES, INC. [US/US]; 325 West Queen Street, Southington, CT 06489 (US).
- (72) **Inventors; and**
- (75) **Inventors/Applicants (for US only):** SROKA, Gary [US/US]; 3311 Shiloh Court, Missouri City, TX 77549 (US). EL-SAEED, Omer [US/US]; 9140 Highway 6N, #2809, Houston, TX 77095 (US).
- (81) **Designated States (unless otherwise indicated, for every kind of national protection available):** AE, AG, AL, AM,

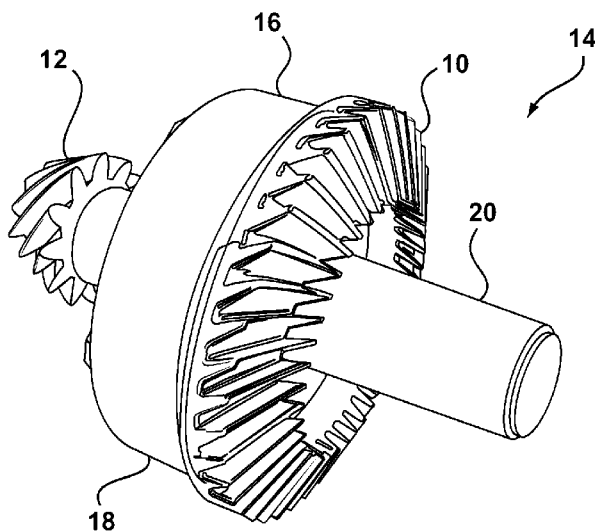
AO, AT, AU, AZ, BA, BB, BG, BH, BR, BW, BY, BZ, CA, CH, CL, CN, CO, CR, CU, CZ, DE, DK, DM, DO, DZ, EC, EE, EG, ES, FI, GB, GD, GE, GH, GM, GT, HN, HR, HU, ID, IL, IN, IS, JP, KE, KG, KM, KN, KP, KR, KZ, LA, LC, LK, LR, LS, LT, LU, LY, MA, MD, ME, MG, MK, MN, MW, MX, MY, MZ, NA, NG, NI, NO, NZ, OM, PE, PG, PH, PL, PT, RO, RS, RU, SC, SD, SE, SG, SK, SL, SM, ST, SV, SY, TH, TJ, TM, TN, TR, TT, TZ, UA, UG, US, UZ, VC, VN, ZA, ZM, ZW.

(84) **Designated States (unless otherwise indicated, for every kind of regional protection available):** ARIPO (BW, GH, GM, KE, LR, LS, MW, MZ, NA, SD, SL, SZ, TZ, UG, ZM, ZW), Eurasian (AM, AZ, BY, KG, KZ, MD, RU, TJ, TM), European (AL, AT, BE, BG, CH, CY, CZ, DE, DK, EE, ES, FI, FR, GB, GR, HR, HU, IE, IS, IT, LT, LU, LV, MC, MK, MT, NL, NO, PL, PT, RO, RS, SE, SI, SK, SM, TR), OAPI (BF, BJ, CF, CG, CI, CM, GA, GN, GQ, GW, ML, MR, NE, SN, TD, TG).

**Published:**

- with international search report (Art. 21(3))
- before the expiration of the time limit for amending the claims and to be republished in the event of receipt of amendments (Rule 48.2(h))

(54) **Title:** MAGNETIC FIXTURE



**Figure 3**

(57) **Abstract:** A fixture is provided for retaining a metal workpiece for contact by finishing media during operation of a media based finishing operation. The fixture comprises a body and a magnet for retaining the workpiece in contact with the body. By use of super-magnetic materials a significant holding force may be achieved.



WO 2011/061686 A1

## MAGNETIC FIXTURE

## BACKGROUND OF THE INVENTION

## 1. Field of the Invention

[0001] The invention relates generally to fixturing arrangements and more particularly to fixturing arrangements for releasably mounting metal components to be treated in a media based finishing process. The invention also relates to methods of finishing engineering components in particular batch finishing where a large number of components are finished together.

## 2. Description of the Related Art

[0002] Procedures for producing a smooth surface finish on metallic components are generally well known. Such procedures include barrel tumbling, abrasive vibratory finishing, grinding, honing, abrasive machining and lapping. Examples of mechanical parts that may be finished using these procedures include splines, crankshafts, camshafts, bearings, gears, continuous velocity (CV) joints, couplings, and journals. Various advantages may be achieved by such finishing including a reduction in wear, friction, noise, vibration, contact fatigue, bending fatigue and operating temperature in the mechanism to which they relate.

[0003] The present invention is concerned with media based processes in which a workpiece is acted upon by freely moving particles or granules of an abrasive or non-abrasive medium or by a fluid. These processes may be distinguished from machining processes in which a machining tool acts on the surface of the workpiece.

[0004] In the automotive industry, there is an ongoing desire to improve efficiency and performance in order to produce more environmentally friendly vehicles. One area of interest lies in improving the surface finish of certain critical components. At present, a major contributor to drive train friction is the rear axle ring and pinion gearset. Media based finishing processes have been identified as a suitable way to achieve the required degree of smoothness for such components. This is discussed in a number of publications including US2005/0202921A1. As yet however such processes are not able to achieve the production volumes required by the industry in a cost-effective manner.

[0005] Various media based techniques are available. Early vibratory finishing techniques used motor-driven vibratory bowls or tubs in which the component would be free floated and allowed to agitate in the presence of abrasive media. By free floated, it is meant the components are allowed to be carried around the vessel by the movement of the media mass. The degree and rate of finishing is primarily controlled by the coarseness, amount and or replenishment of the abrasive grit used in the media mass. Such processes are based on the mass finishing techniques used, for example, for polishing stainless steel tool handles in which ever finer polishing media is used to achieve the desired degree of finish. These procedures are generally recognized as being too slow for use on hardened engineering components such as case-carburized gearsets.

[0006] Further procedures have been developed in which increased levels of mechanical energy are imparted onto the component by moving the component through relatively stationary media. One such procedure is known as drag finishing and is described in e.g. US 4,446,656 to Kobayashi, Another drag finishing machine is described in US 6,918,818 to Böhm, the contents of which are also incorporated herein by reference in their entirety. In this device, individual components may be fixtured to a drive spindle for finishing. The total throughput of components is determined by the process time and the fixturing time for connecting and disconnecting components from the drag spindle.

[0007] Another procedure that can achieve an ultra-smooth superfinished surface is chemically accelerated vibratory finishing (CAVF). A chemically accelerated vibratory finishing technique has been developed and described in numerous publications by REM Chemicals, Inc. This technique may be used to refine metal parts to a smooth and shiny surface and has been used commercially for many years. U. S. Patent No. 4,818,333 to Michaud and U.S. Patent 7,005,080 to Holland, the contents of which are incorporated herein by reference in their entirety, disclose this improved finishing technique. The use of such processes in the automotive industry has been described in an article by Winkelmann, L., J. Holland and R. Nanning in AGMA Paper 04FTM13, entitled "Superfinishing Motor Vehicle Ring and Pinion Gears". With such a process, a desired finish of around 0.25 micron Ra may be achieved in 30 – 60 minutes. Such a process is generally unacceptably long for integration into a production line environment.

[0008] A number of media based processes can be carried out as batch processes in a bowl or tub on a number of parts at a time. This can reduce the processing time per part but it can unfortunately also lead to components knocking against one another, causing damage and resulting in scrapped parts. Furthermore, it is not convenient for components that have been individually identified or matched. For gear assemblies, it is often the case that two or more components are matched as a gear-set, for example, by a lapping process. Thereafter, it is desirable that the matched parts are kept together during subsequent operations. For such components, batch finishing is generally not suitable as it requires complicated marking and subsequent identification of all components.

[0009] In an attempt to overcome the problems of batch processes, vibratory machines have been partitioned with dividers. This is however only practical with a small number of partitions whereby relatively few gear-sets can be finished in each machine. Another problem is that parts are prone to lodge in corners of the bowl, resulting in a non-uniform finish and scrapping of the part. According to GB1018759A, individual containers containing workpieces and finishing medium may be located upon a vibratory machine. The containers are attached to a carrier table by magnets. Such an arrangement of individual containers would not appear practical in keeping large numbers of components separate from one another. It is also doubted that it would be effective on metal components which would themselves be attracted by the magnets.

[0010] In conventional machining processes, fixturing devices are used to locate workpieces and prevent them from moving. Various forms of fixturing device are known in the art including clamps, vices, chucks, jigs and the like. For production line manufacturing, any fixturing device must be easy to connect and release, since these procedures will usually add to the overall process time. Fixturing devices of this type are not however commonplace in media based processes and do not appear readily suited for such use. The media used is often relatively small and can become easily lodged in screw threads, clamps and tool openings such as screw and bolt heads. Additionally, the finishing process itself can be detrimental to such fixtures making them difficult to open. For these reasons, conventional mechanical fixtures are not ideally suited for use in media based finishing environments.

[0011] A number of magnetic devices are known in which electromagnetic clamps are used which can easily be switched on and off in order to retain and release a workpiece. Examples of such devices are shown in GB847394, EP 1022089 A2 and US 2,913,853. These devices would also not lend themselves to use in a media based finishing environment, where the workpiece is substantially surrounded by and free-floated in the media. Operating with active aqueous chemistry would also pose a serious safety risk. Furthermore, such fixturing devices must be adequately protected from ingress of media or finishing chemistry.

[0012] In an alternative device for media based finishing shown in JP57189764A, an electromagnet is used for the purpose of delivering workpieces to a vibratory bowl. The workpieces are guided to move spirally within the bowl by a guide part. Although some reduction in contact damage between components may be achieved, the arrangement does not separately retain matched components and is not suitable for all shapes and size of workpiece.

[0013] Thus, there is a particular need for a device and procedure that allows at least some of these problems to be overcome.

#### BRIEF SUMMARY OF THE INVENTION

[0014] The present invention addresses these problems by the use of a magnet to retain a metal workpiece during a media based finishing operation. In this manner simplified connection and disconnection may be achieved and the workpieces can be prevented from knocking and damaging one another even in a batch process. Furthermore, the magnet can be used to keep particular components together and simplify subsequent identification. Magnets can be quickly and easily released with little additional process time and are generally sufficiently strong to withstand the forces applied in e.g. vibratory bowls.

[0015] In one preferred embodiment, the method may take place in a drag-finishing machine having a drive arrangement arranged to drive or push the magnetic fixture through the media. In this context, a drag-finishing machine is understood to be a machine that applies a resultant force to the workpiece to establish relative movement between the media and the workpiece. This may be achieved by moving the workpiece through the media, moving the media past the workpiece, or a combination of both. In general, the forces acting upon a workpiece during drag finishing are greater than those experienced in conventional vibratory finishing. For this

reason, it is preferred that the magnetic fixture is generally behind the workpiece in the direction of the relative movement. The force of the media will then act to press the workpiece onto the fixture and the strength of the magnets required may then be lower than had the fixture led the workpiece.

[0016] In an alternative embodiment of the invention, the process may take place in a vibratory mounted tub or bowl. As the skilled person will understand, such a tub or bowl may be filled with appropriate media and chemistry as required in order to perform a vibratory finishing process.

[0017] According to an important aspect of the invention, the magnetic is provided on or in a fixture which is freely moveable within the receptacle about at least one axis. Free movement in this context is understood to distinguish from arrangements where the fixture is either rigidly connected to or driven by part of the machine. Since the fixture may rotate freely about an axis, the workpiece may also rotate with the same freedom. Such free movement may be provided by a free-wheeling axle shaft or disk on which the fixture is mounted. In certain embodiments, the fixture is preferably freely moveable in all directions of movement. In particular, for operation in a vibratory tub or bowl, the fixture itself may be free-floated within the bowl, carrying the workpiece or workpieces. This may have various advantages as will be understood from the following.

[0018] In one embodiment, a plurality of magnetic fixtures may be mounted together on a mounting structure. This may allow a number of workpieces to be loaded onto the single mounting structure and thereafter handled as a single unit. The number of fixtures and/or workpieces may vary from two, to a hundred or more. The workpieces may be transported together to and from the finishing machine and may be finished together e.g whereby the whole mounting structure is immersed in the media.

[0019] In a further embodiment, each workpiece may comprise a plurality of matched components mounted together on the fixture. The fixture thus serves to identify the matched components and can also ensure that all of the components are subjected to the same or similar finishing process and conditions. The components could comprise a pair of matched gears such as a ring and pinion. Alternatively, they could comprise a complete mechanism, such as all the gears from a particular gearbox.

[0020] In an embodiment of the invention, the drive arrangement may comprise a force limiting control to limit a force applied to the magnetic fixture to a value lower than a retention force between the magnetic fixture and the workpiece. Active control of the drive arrangement in this manner may serve to avoid workpieces becoming separated from their fixtures. The skilled person will understand that various indicators can be used to prevent disengagement including contact and proximity sensors between the workpiece and the fixture. In response to excess force or (imminent) disconnection of a workpiece, the drive arrangement may be stopped or its speed reduced.

[0021] The invention also relates to a fixture for retaining a metal workpiece for contact by finishing media during operation of a media based finishing operation, the fixture comprising a body and a magnet for retaining the workpiece in contact with the body. By use of such a fixture, the benefits of the process as described above may be realized.

[0022] In a most preferred embodiment, the magnet is a permanent magnet. In particular, the skilled person will understand that electromagnets may not be suitable for use with a fixture that is to be free-floated in a vibratory machine. For this reason, the fixture preferably does not comprise an electromagnet. Most preferably, the magnet is a so-called super-magnet such as a magnet based on the rare earth materials neodymium, samarium or the like.

[0023] In a further preferred embodiment the body comprises plastics material. An advantage of such plastics material is that it may be chosen to be substantially resistant to the finishing media and chemicals used. Furthermore, it may be relatively soft, preventing damage to either the workpieces or the media. Preferred plastics materials are organic engineering polymers such as high density polyethylene (HDP) and polyoxymethylene such as Delrin™ available from Dupont. Although plastics materials are preferred for their ease of manufacture and chemical resistance, many other materials could be employed, in particular non-magnetic materials that can withstand the chemistry being used. Such materials could include 316 stainless steel, brass and even wood.

[0024] In a particular embodiment of the invention, the magnet may be substantially embedded within the body. This allows the magnet to be protected by the body from exposure to the media. It also may prevent direct contact between the magnets and the workpiece. The magnet or magnets may be located within a bore or cavity of the body and subsequently

sealed. Alternatively, they may be incorporated or encapsulated within a plastic body during a manufacturing or moulding procedure. Most preferably, the body has a smooth outer surface without openings or locations where media may lodge.

[0025] In a still further embodiment of the invention, the fixture may comprise a plurality of magnets. These may be arranged e.g. around a periphery of the fixture in a shape corresponding to a shape of the workpiece to be received. Alternatively, the plurality of magnets may be for retaining different workpieces or components.

[0026] Although the fixture may have a flat face for receiving the workpiece, in another preferred embodiment of the invention, the body may comprise a profiled seat. The seat is preferably of an at least partially complementary shape to the surface of the workpiece which it is to engage. By providing a profiled seat, the exact location of the workpiece may be better determined or maintained. Furthermore, accidental disconnection may be prevented since lateral forces may be resisted by mechanical engagement of the seat and workpiece. Such a seat may provide a certain amount of mechanical interference fit between the fixture and the workpiece. Nevertheless, the axial retaining force preventing separation of the workpiece is preferably provided primarily by the magnetic force of attraction. Preferably the magnetic force provides more than 60% of the axial retaining force, most preferably more than 90% of such force. The seat may also be provided with a seal such as an O-ring, lip, ridge or the like in order to prevent ingress of media or chemicals between the workpiece and the fixture.

[0027] In yet another preferred embodiment each workpiece may comprise a plurality of matched components and the body has a plurality of seats, each arranged for receiving a respective component. The seats may be provided on the same face or on different faces of the fixture. In a drag finishing embodiment it may be desirable that all components are located on the same face so that they are all exposed to similar media conditions. In a vibratory finishing arrangement components may be located on opposing faces.

[0028] The invention also relates to a mounting structure comprising a plurality of fixtures as described above. The mounting structure may take any number of different configurations according to the workpieces being finished and the finishing method employed. In one preferred form, the mounting structure comprises a plurality of arms mounted on an axle in a tree structure, each supporting a respective fixture in spaced relationship to one another.

-8-

[0029] For the reasons as described above, each fixture is preferably mounted to be freely rotatable on the mounting structure about at least one axis. The mounting structure itself may also be freely rotatable about one or more axes or may be arranged to be free floating within a vibratory tub or bowl. In one particular embodiment, the mounting structure may also carry spacing members arranged to space the fixtures from other objects to prevent damage to the workpieces. The spacing members may form a body of revolution, within which the workpieces and fixtures are located.

[0030] While the present invention is applicable to most mechanical components, a preferred application of the invention is to the finishing of ring and pinion gear sets. As discussed above, finishing such components is of great importance to the automotive industry and no adequate solution has yet been found for efficient processing of matched ring and pinion pairs.

[0031] The invention may be used in combination with a machine comprising a receptacle for containing a quantity of finishing media, a drive arrangement for inducing relative motion between the workpiece and the media whereby the magnetic fixture is for retaining the workpiece within the receptacle during the finishing procedure.

[0032] Preferably, the workpiece is retained substantially only by the magnet and is not significantly retained by other means. In use, an operator thus need only separate the workpiece from the magnet by the force required to overcome magnetic attraction. Additional locking and fixturing is not required and the process time associated with fixturing is significantly reduced.

[0033] According to a preferred method of use, the finishing operation comprises chemically accelerated finishing. This may be performed using vibratory motion or by drag finishing. In the latter case, the workpiece is preferably driven through the media ahead of the magnetic fixture such that the media exerts a force on the workpiece tending to press it against the fixture.

#### BRIEF DESCRIPTION OF THE DRAWINGS

[0034] The features and advantages of the invention will be appreciated upon reference to the following drawings, in which:

[0035] FIG. 1 is a schematic perspective view of a vibratory bowl for use with a first embodiment the invention;

[0036] FIG. 2 is a schematic perspective view of a ring and pinion gear;

[0037] FIG. 3 is a perspective view of a fixture according to the first embodiment of the invention;

[0038] FIGS 4A and 4B are exploded perspective views of the fixture of FIG. 3;

[0039] FIG. 5 shows a perspective view of fixtures in use according to the first embodiment of the invention;

[0040] FIG. 6 shows a side elevation of a drag finishing machine for use with a second embodiment of the invention;

[0041] FIGS 7A to 7D show various views of a fixture according to the second embodiment;

[0042] FIG. 8 shows a perspective view of a vibratory tub for use with a third embodiment of the invention;

[0043] FIG. 9A shows an exploded perspective view of the fixture used in the third embodiment;

[0044] FIG. 9B shows a bottom view of the fixture of FIG. 9A;

[0045] FIG. 10 shows a perspective view of a mounting structure according to the third embodiment;

[0046] FIG. 11 shows a bottom view of a mounting structure according to a fourth embodiment of the invention;

[0047] FIG. 12 shows a schematic side view of a fixture according to a fifth embodiment of the invention; and

[0048] FIGS 13A and 13B show respective bottom and side schematic views of a sixth embodiment of the invention.

## DESCRIPTION OF ILLUSTRATIVE EMBODIMENTS

[0049] The following is a description of certain embodiments of the invention, given by way of example only and with reference to the drawings. Referring to FIG. 1, a vibratory finishing machine 1 is shown in the form of a vibratory bowl 2. The bowl is substantially filled with non-abrasive finishing media 4 and finishing chemicals 6. A drive arrangement 5 is provided beneath the bowl 2 and serves to vibrate the bowl at a chosen frequency and amplitude of oscillation. In use in a conventional manner, workpieces 8 to be finished are placed freely in the bowl 2 and are acted upon by the media 4 and chemicals 6 according to e.g. the method described in U. S. Patent No. 4,818,333 to Michaud. According to this method, the chemistry forms a conversion coating on the surfaces of the components being treated. Action of the media 4 causes the relatively soft coating to be removed from the high points of the surfaces, while leaving substantially intact the coating on the lower surface areas. The coating is continuously repaired over metal exposed during operation leading to a planarizing effect on the surface.

[0050] In FIG. 2, a ring 10 and pinion 12 assembly is shown. The ring 10 and pinion 12 form part of an automobile rear-axle and will be used in the following as exemplary workpiece components in relation to which the invention will be further explained. The skilled person will immediately understand that other components may also be finished in a similar manner and that the invention extends equally to machines, fixtures and methods for finishing any appropriate engineering components. The ring 10 is an annular element having a ring shaped gear surface 9. The pinion 12 has a hypoid gear surface 11 and a stub axle 13.

[0051] FIG. 3 shows a fixture 14 according to a first embodiment of the invention. The fixture 14 comprises a body 16 formed of a disk 18 and a shaft 20 onto which the ring 10 and pinion 12 are respectively connected. In the depicted embodiment, the body 16 is formed of a single piece of Delrin<sup>TM</sup>.

[0052] FIGS 4A and 4B show exploded perspective views of the fixture 14 of FIG. 3 from two different angles. As can be seen, the disk 18 has a top face 22 and a bottom face 24. Bores 26 in the top face 22 extend through the disk to a distance of about 1.5 mm from the bottom face 24. Magnets 28 are received within the bores 26, which are closed by plugs 30 of Delrin<sup>TM</sup>. The magnets 28 are formed of neodymium material (Nd<sub>2</sub>Fe<sub>14</sub>B) and each can exert a

retaining force of around 4 Kg when acting through the material of the bottom face 24 of the disk 18 in this manner. Five bores 26 are spaced around the circumference of the disk 18, of which four can be seen in the Figures. Furthermore, a central bore 36 through the shaft 20 can also be seen. An O-ring 40 is arranged to provide a seal around the top surface 42 of the shaft 20. The bottom face 24 is provided with a seat 32 in the form of a step. The step corresponds in diameter with an inner diameter of the ring gear 10. A further magnet 38 can be seen located in the bottom end of the central bore 36. The further magnet 38 is larger in dimensions than the magnets 28.

[0053] The stub axle 13 can thus be inserted into the central bore 36 of the shaft 20 until it is engaged by the further magnet 38. This corresponds to the position where the base of the hypoid gear 11 has seated against the top surface of the shaft 20 and is in sealing engagement with the O-ring 40. During use, this sealing engagement protects the rear side of the hypoid gear 11 and stub axle 13 from entering into contact with finishing chemicals. To remove the ring 10 and pinion 12 from the fixture 14, the shaft 20 may be gripped tightly and a twisting motion applied to either the ring 10 or pinion 12 in order to break the magnetic attractive force. It will be understood that other arrangements and jigs may be provided to assist in removal of components from such fixtures.

[0054] The loaded fixture 14 may be used in the vibratory machine 1 as shown in FIG. 1. To this end, and as shown in FIG. 5, a mounting structure 42 is provided for mounting a plurality of fixtures 14. The mounting structure 42 comprises an annulus 44 having a plurality of openings 46 arranged around its circumference. The shaft 20 of each fixture 14 may be inserted through a respective opening 46 prior to attachment of the pinion gear 12. The fixtures 14 are freely rotatable within the openings 46. In this manner, a large number of fixtures 14 can be mounted onto the mounting structure 42. Once loading is complete, the complete mounting structure 42 may be lowered into the bowl 2 of the vibratory machine 1 and floated in the media 4. During use, the fixtures 14 are free to rotate around their respective shafts 20 allowing an even distribution of finishing action on the components. Using the process as described above, up to 40 components may be finished together in a total process time of about 60 minutes. Fixturing of the components onto the fixtures 14 and

mounting structure 42 can take place off-line and does not therefore increase the total process time for the machine 1.

[0055] In an alternative (non-illustrated) embodiment, the fixture may be allowed to tumble freely in a bowl or tub. This may be the case where impact between workpieces is not a significant issue but nevertheless, pairing of matched components is desired. In the case of a freely tumbling version, it could also be desirable to locate both a ring and a pinion on the same face of the fixture in order to promote tumbling. Such an arrangement is shown below in the context of a second embodiment of the invention.

[0056] A second embodiment of the invention is shown in FIGS 6 for use in drag-finishing. In the description of this embodiment, like reference numerals preceded by 100 will be used to denote similar features.

[0057] According to FIG. 6, there is shown a drag-finishing machine 100 having a bowl 102 containing non-abrasive media 104. A drive arrangement 105 causes rotation of arms 107 to force workpieces 108 through the media 104. Each workpiece 108 is carried by a fixture 114. The arms 107 rotate together around the bowl 102 and also each rotates around its own axis. The arms 107 are positioned at an angle  $\alpha$  with respect to the vertical. In addition to media 104, finishing chemistry 106 is provided in bowl 102 as described in co-pending application No 61/215981, the contents of which are hereby incorporated in their entirety. It will be understood that the invention is equally applicable to use with abrasive media in the absence of accelerating chemistry as carried out in conventional drag finishing processes.

[0058] FIGS 7A to 7D illustrate in further detail the fixture 114 for carrying a ring 110 and pinion 112 for finishing in the machine 100. Referring to FIG. 7A, the fixture 114 is shown in side view to comprises a body 116 formed of a disk 118 and a shaft 120. In the depicted embodiment, the disk 118 is formed of a single piece of Delrin<sup>TM</sup>. The shaft 120 is made of steel and carries a plate 121 which is semi-permanently connected to a top face 122 of the disk 118 by bolts 119. The shaft 120 is connected in use to a respective arm 107 of the machine 100. The bottom face 124 is provided with a seat 132 and a step 133.

[0059] FIG. 7B shows an exploded perspective view of the fixture 114 whence it can be seen that the disk 118 has a central bore 136. A total of five bores 126 are distributed around

the circumference of the disk 118. Five further bores 126 are distributed on the step 133 around the central bore 136. Each of the bores 126 houses a magnet 128 and is closed by a plug (not shown) as in the previous embodiment.

[0060] FIG. 7C shows a perspective view of the fixture 114 with the ring gear 110 attached and located by the seat 132 and step 133.

[0061] In FIG. 7D the pinion gear 112 is also attached. As can be seen, the pinion 112 sits on the step 133 within the ring gear 110. The stub axle 113 inserts within the central bore 136 and is sealed by interaction of an O-ring with the rear side of the hypoid gear 111.

[0062] In use of the machine 100, the drive arrangement 105 drives the arms 107 through the media 104 at the angle  $\alpha$ . This ensures that the components 110, 112 are always pushed forwards through the media 104 by the fixture 114. Even though the forces encountered in the use of drag finishing machines are relatively high, disengagement of the magnets 128 is prevented by the fact that the media 104 acts to push the ring 110 and pinion 112 against their respective seats. Furthermore, the seat 132, step 133 and central bore 136 all act to restrain any lateral movement. On completion of the finishing procedure, the arms 107 may be raised from the bowl 102 and the ring 110 and pinion 112 can be physically pulled away from the fixture 114. It will of course be understood that appropriate levers, wedges or other implements may be used where necessary to assist this operation. After removal of the ring 110 and pinion 112 from the fixture 114, they may be demagnetized using conventional procedures.

[0063] A machine 200 according to a third embodiment of the invention is shown in FIG. 8. In the following, similar features to the first embodiment are denoted by like reference signs preceded by 200. The machine of FIG. 8 is in the form of an elongate vibratory tub 202 to be filled with media 204 and chemicals 206 as in the earlier embodiments. The tub 202 is driven to vibrate by a drive arrangement 205.

[0064] FIG. 9A shows a fixture 214 for use in the tub 202 of FIG. 8, in exploded view together with a ring 210 and pinion 212. The fixture 214 is substantially the same as that of FIGS 7A-D and comprises disk 218, magnets 228 in bores (not shown) and central bore 236.

[0065] FIG. 9B shows the fixture 214 in bottom view. The disk 218 is connected by bolts 219 to a plate 221 provided on arm 207 of a mounting structure 242.

[0066] The complete mounting structure 242 is shown in perspective view in FIG 10. It comprises an axle 248 carrying a plurality of arms 207 extending radially from the axle 248 like spokes. The arms 248 are also spaced from each other along the length of the axle 248 and offset in the circumferential direction. Each arm 207 carries a respective fixture 214 and workpiece 208. In the illustrated embodiment a total of forty eight fixtures can be carried by the mounting structure 242 without interfering with one another. At either end of the axle 248 is a wheel 250. The wheels 250 are of such dimension that, when placed on a flat surface, they hold the fixtures 214 and workpieces 208 clear of the surface.

[0067] In use the mounting structure 242, fully loaded with workpieces 208, is lowered into the tub 202. On operating the drive arrangement 205, the mounting structure 242 sinks into the media 204 until it is submerged. Movement of the media 204 causes it to slowly rotate, whereby the wheels 250 guide it with respect to the sides and base of the tub 202. As it rotates, the different workpieces 208 are all exposed to similar finishing conditions. On completion, the whole mounting structure may be removed from the tub 202 and the workpieces 208 removed as in previous embodiments. Another fully loaded mounting structure 242 may be exchanged whereby processing in the tub 202 can continue almost uninterrupted.

[0068] Many other alternative embodiments and designs may be considered, depending upon the workpieces and components to be finished and the finishing machines available. According to FIG. 11, a further embodiment is shown of the underside of an arrangement 300 in which fixtures 314 are rotatably mounted on mounting structures 342 which can themselves rotate. The fixtures 314 are not shown in further detail but may be essentially identical to those of FIG. 7. The arrangement 300 can be placed over the hub of a vibratory bowl, with the rings 310 and pinions 312 immersed in the media. The mounting structures 342 may be driven to rotate or may be freely rotated by the media.

[0069] In a further alternative arrangement according to FIG. 12, a fixture 414 may be rotatably mounted on an arm 407 of the type used in FIG. 9 or FIG. 10, mounted to an axle 448. In this embodiment a plate 421 provided on the fixture 414 is bolted to the disk 418 on

which a ring 410 and pinion 412 are held. The plate 421 is supported between spaced flanges 452. This allows the fixture 414 further freedom to move laterally and axially on the arm 407 and also to rotate with movement of the media.

[0070] In a still further arrangement according to FIGS 13A and 13B, a mounting structure 542 is arranged for mounting across a vibratory tub. A ring 510 and pinion 512 are separately mounted to magnetic fixtures 514 that are rotatably mounted to the mounting structure 542.

[0071] Thus, the invention has been described by reference to certain embodiments discussed above. It will be recognized that these embodiments are susceptible to still further modifications and alternative forms well known to those of skill in the art, in addition to those described above without departing from the spirit and scope of the invention. Accordingly, although specific embodiments have been described, these are examples only and are not limiting upon the scope of the invention.

## WHAT IS CLAIMED IS:

1. Use of a magnet to retain a metal workpiece during a media based finishing operation.
2. The use according to claim 1, wherein the workpiece is retained substantially only by the magnet.
3. The use according to claim 1 or claim 2, wherein the magnet comprises a permanent magnet, preferably a super-magnet.
4. The use according to any preceding claim, wherein the finishing operation comprises chemically accelerated finishing.
5. The use according to any preceding claim, wherein the workpiece comprises a ring and pinion gear set.
6. The use according to any preceding claim, wherein the media based finishing operation takes place in a machine comprising:
  - a receptacle for containing a quantity of finishing media;
  - a drive arrangement for inducing relative motion between the workpiece and the media; and
  - whereby the magnetic fixture retains the workpiece within the receptacle during the finishing operation.
7. The use according to claim 6, wherein the machine is a drag-finishing machine and the method comprises driving the magnetic fixture through the media, whereby preferably the

workpiece is driven through the media ahead of the magnetic fixture, such that the media exerts a force on the workpiece tending to press it against the fixture.

8. The use according to claim 6, wherein the receptacle is a vibratory mounted tub or bowl.

9. The use according to any of claims 6 to 8, wherein the magnetic fixture is freely moveable within the receptacle about at least one axis, preferably freely moveable in all directions of movement.

10. The use according to any of claims 6 to 9, wherein a plurality of magnetic fixtures are mounted together on a mounting structure.

11. The use according to any of claims 6 to 10, wherein each workpiece comprises a plurality of matched components mounted together on the fixture.

12. The use according to any of claims 6 to 11, further comprising controlling the drive arrangement to limit a force applied to the magnetic fixture to a value lower than a retention force between the magnetic fixture and the workpiece.

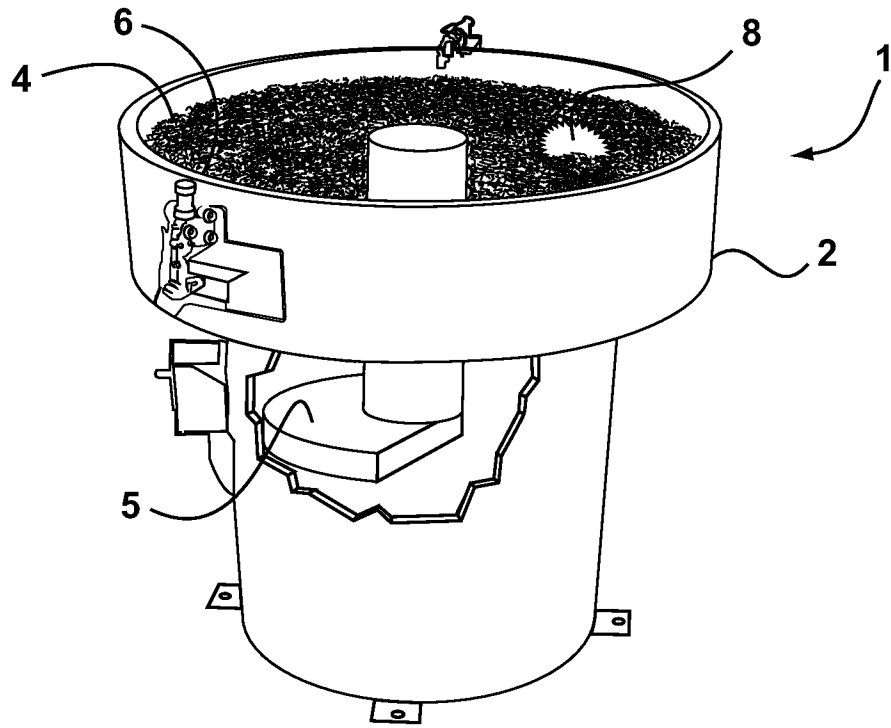
13. A fixture for retaining a metal workpiece for contact by finishing media during operation of a media based finishing operation, the fixture comprising a body and a magnet for retaining the workpiece in contact with the body.

14. The fixture according to claim 13, wherein the magnet is a permanent magnet, preferably a super-magnet.

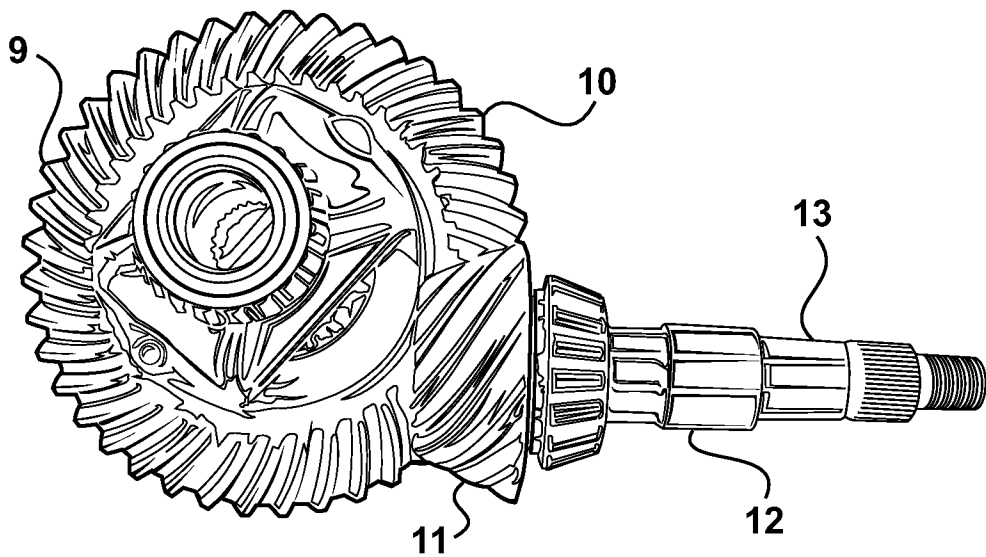
15. The fixture according to claim 13 or claim 14, wherein the body comprises plastics material.
16. The fixture according to any of claims 13 to 15, wherein the magnet is substantially embedded within the body.
17. The fixture according to any of claims 13 to 16, comprising a plurality of magnets.
18. The fixture according to any of claims 13 to 17, wherein the body comprises a seat having a profile for locating the workpiece.
19. The fixture according to any of claims 13 to 18, wherein each workpiece comprises a plurality of matched components and the body has a plurality of seats, each arranged for receiving a respective component.
20. A mounting structure comprising a plurality of fixtures according to any of claims 13 to 19.
21. The mounting structure according to claim 20, comprising a plurality of arms, each supporting a respective fixture in spaced relationship to one another.
22. The mounting structure according to claim 20 or claim 21, wherein each fixture is mounted to be freely rotatable on the mounting structure about at least one axis.
23. The mounting structure according to any of claims 20 to 22, wherein the mounting structure is arranged to be freely rotatable about at least one axis within a vibratory tub or bowl.

24. The fixture or structure according to any of claims 13 to 23, wherein the workpiece comprises a ring and pinion gear set.

1/10

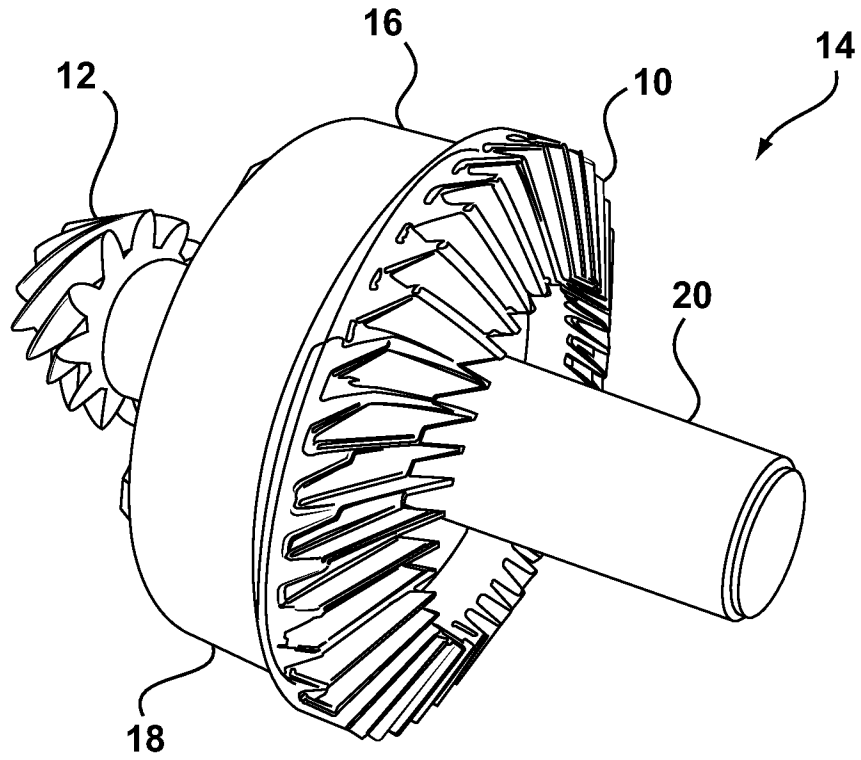


**Figure 1**



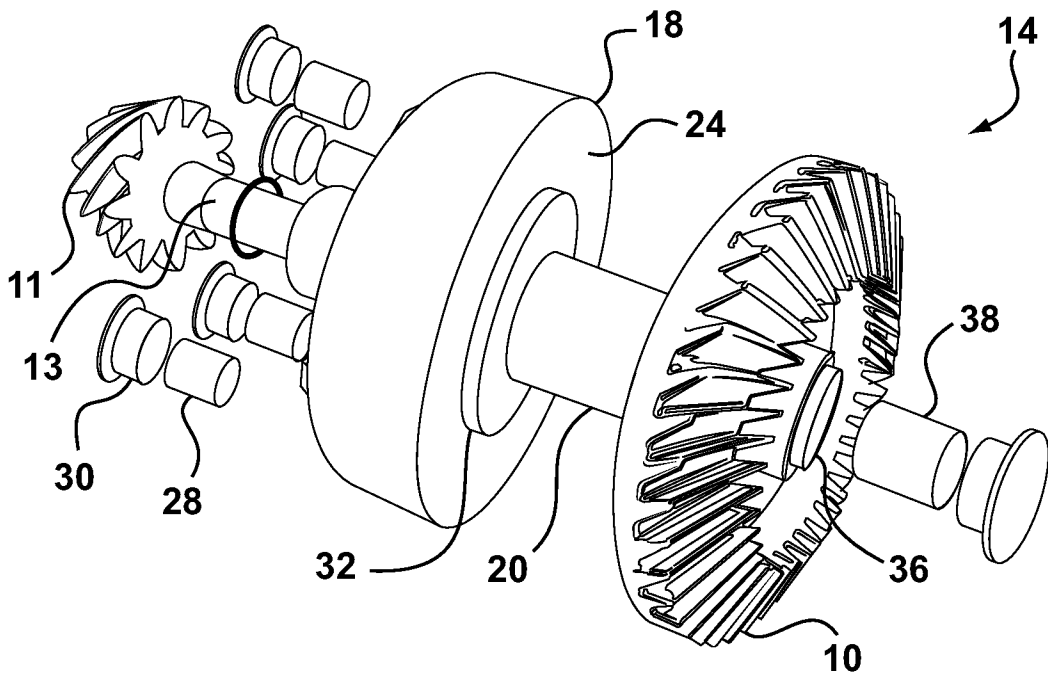
**Figure 2**

2/10

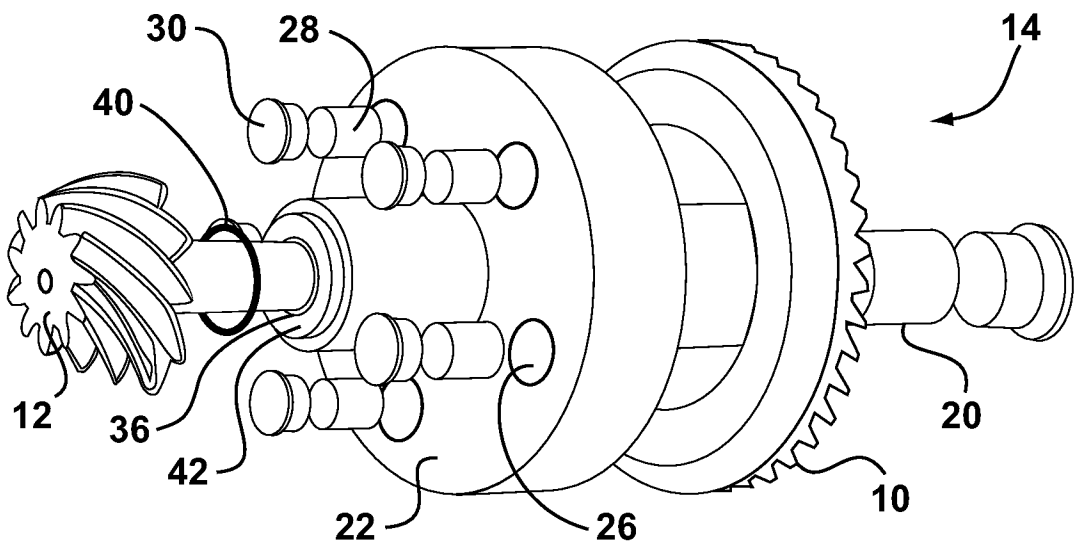


**Figure 3**

3/10

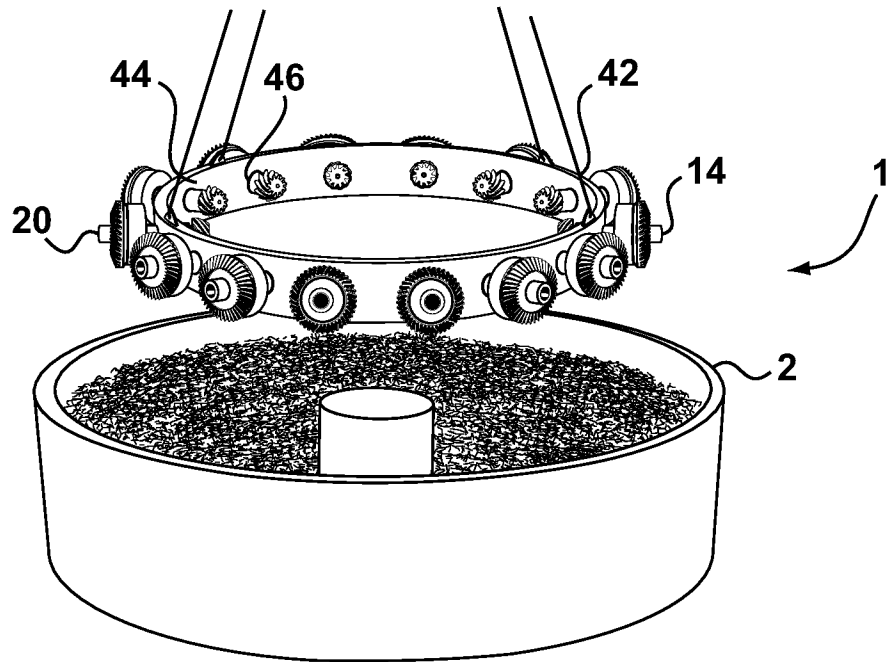


**Figure 4A**

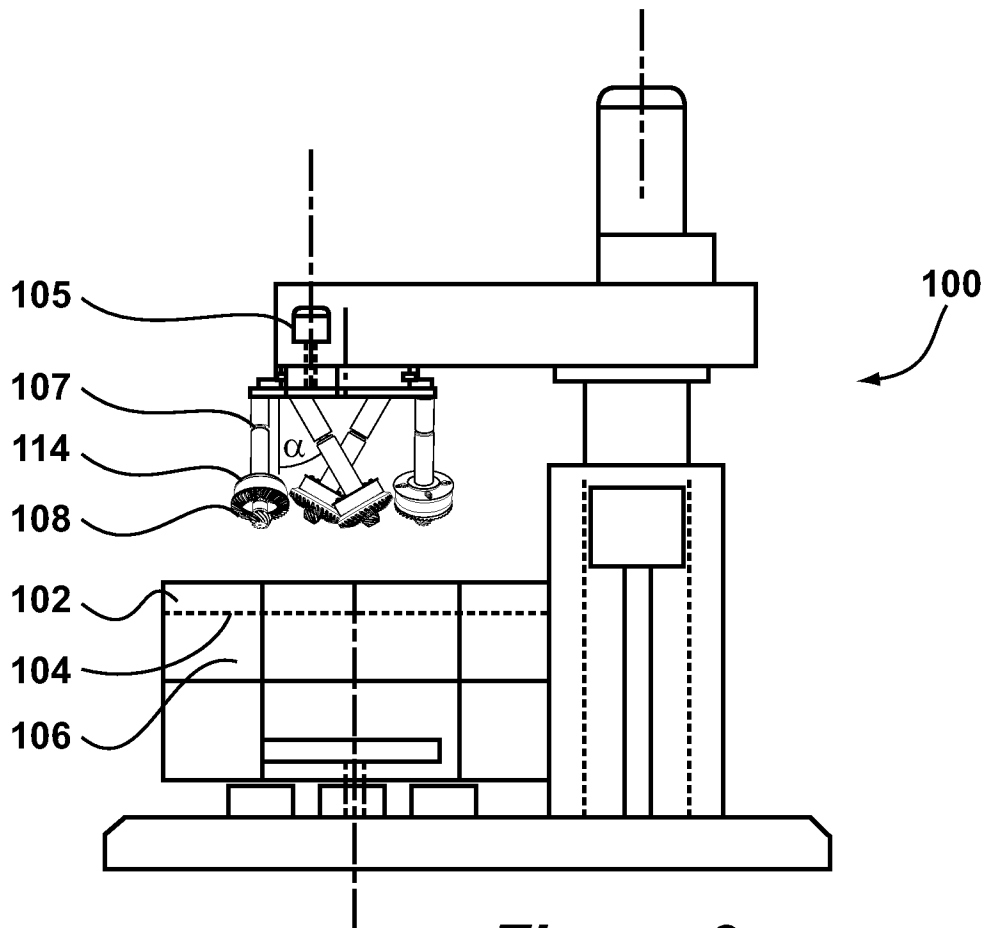


**Figure 4B**

4/10

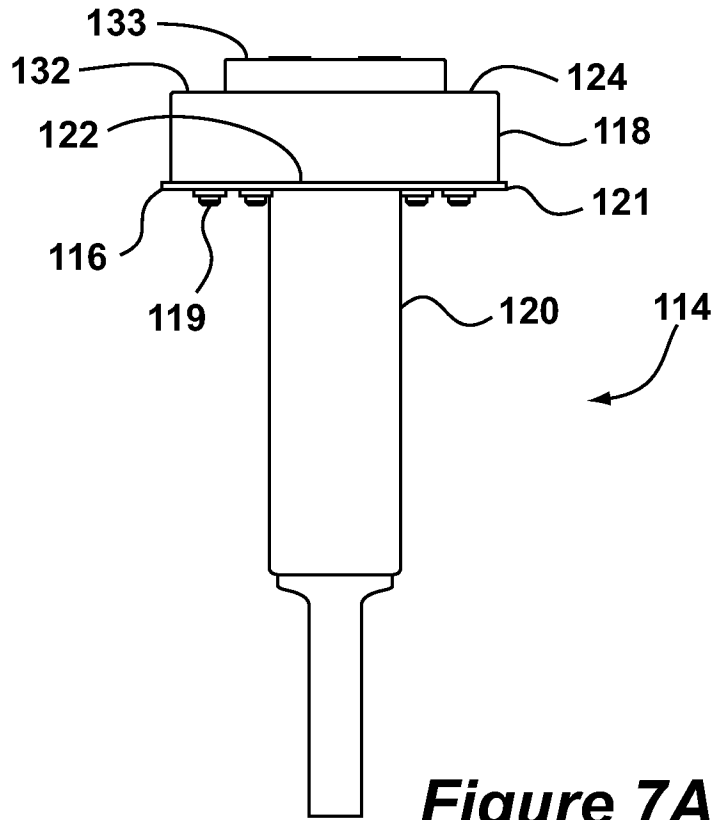


**Figure 5**

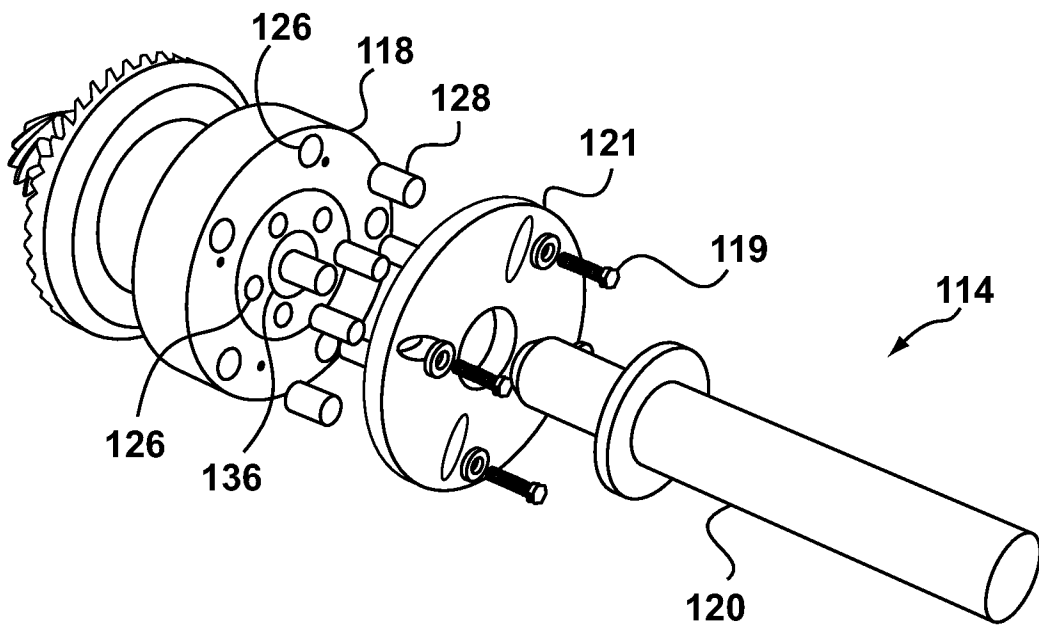


**Figure 6**

5/10

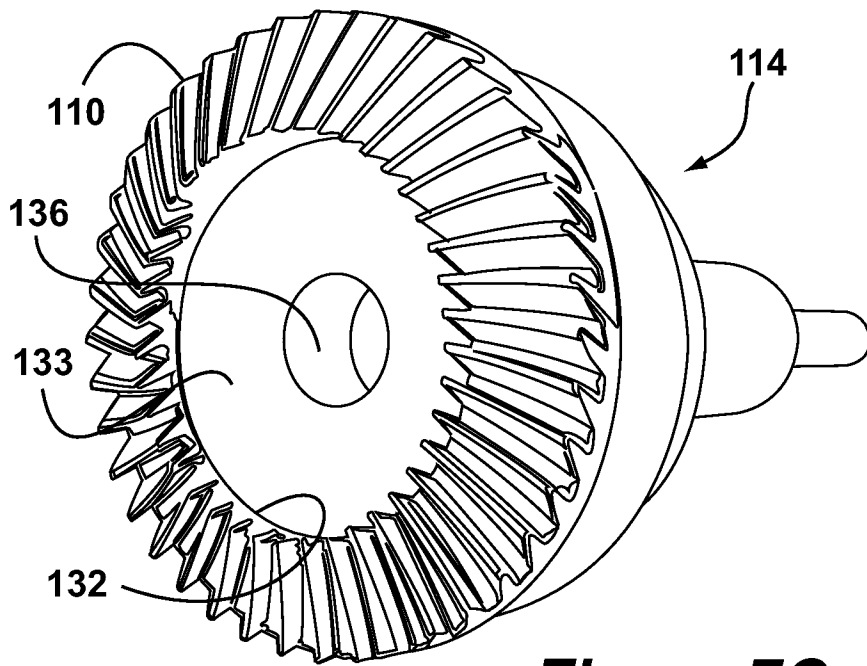


**Figure 7A**

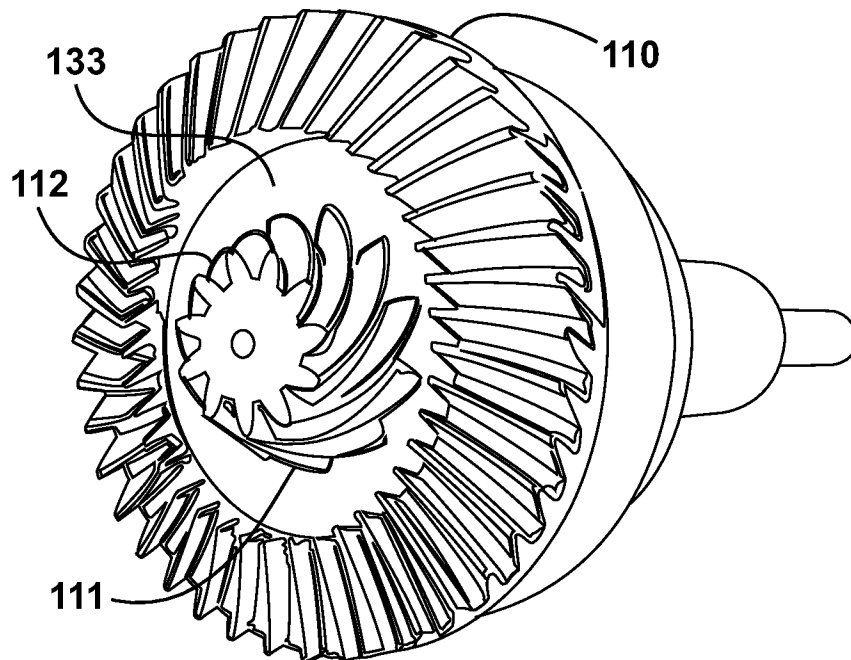


**Figure 7B**

6/10

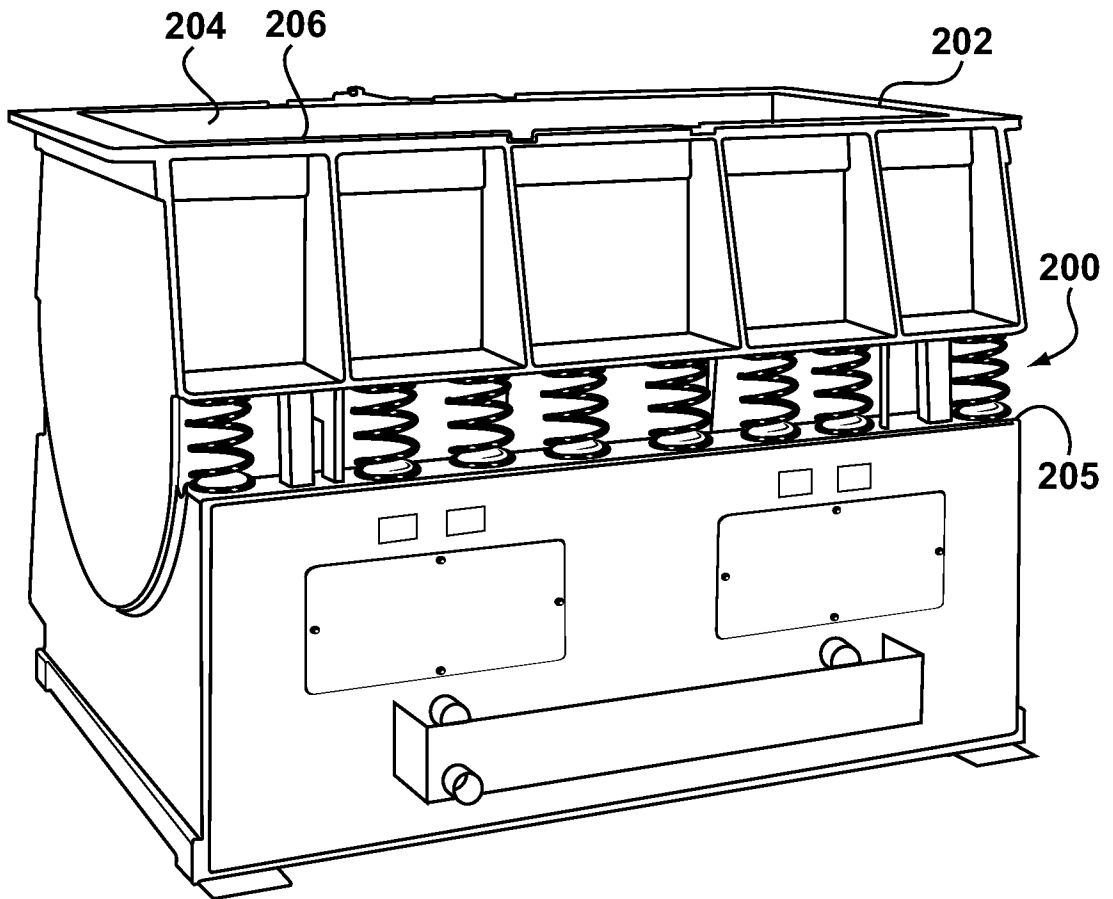


**Figure 7C**



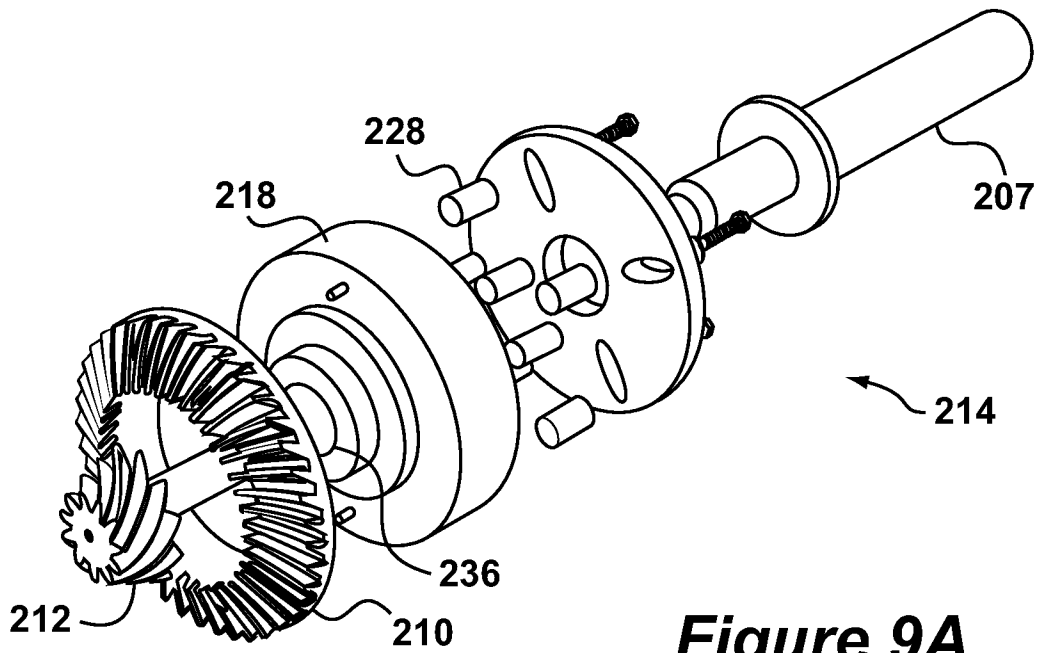
**Figure 7D**

7/10

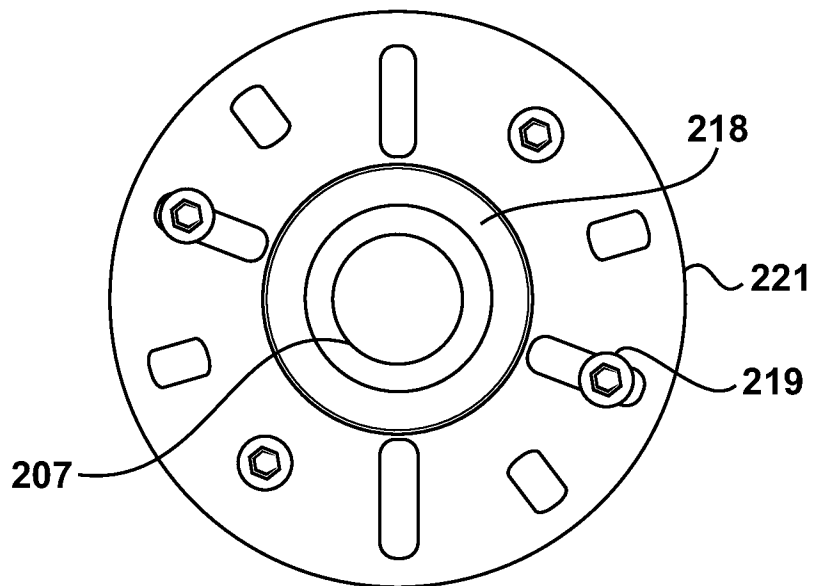


**Figure 8**

8/10



**Figure 9A**



**Figure 9B**

9/10

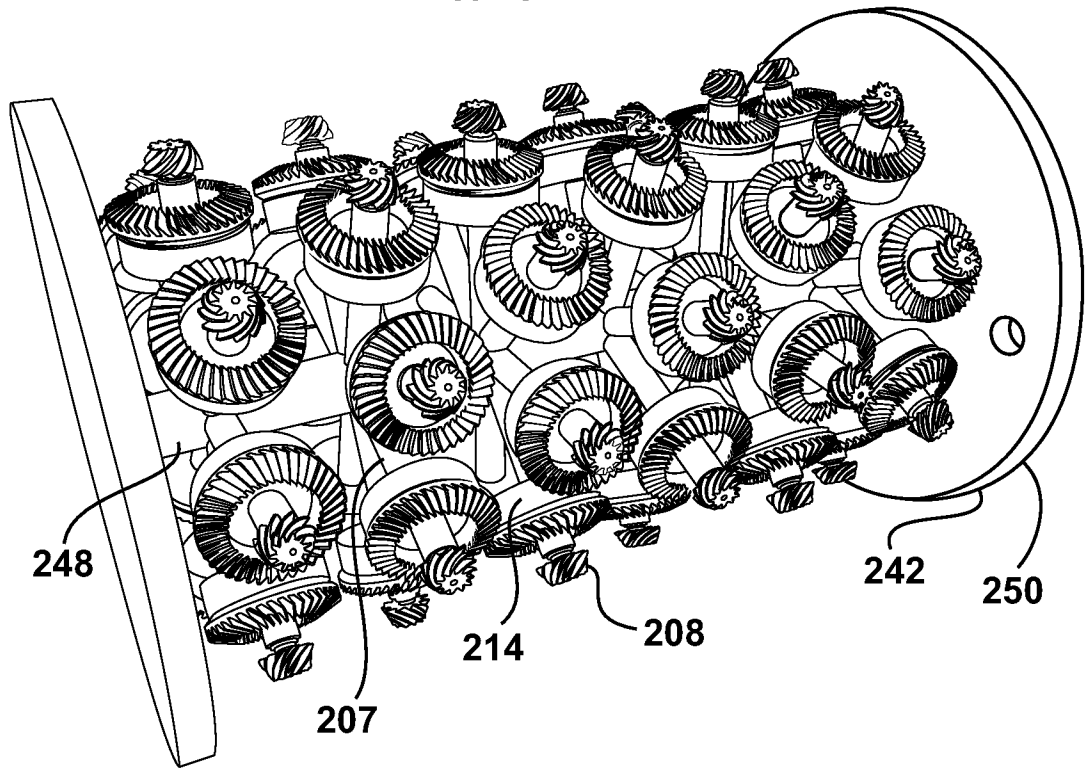


Figure 10

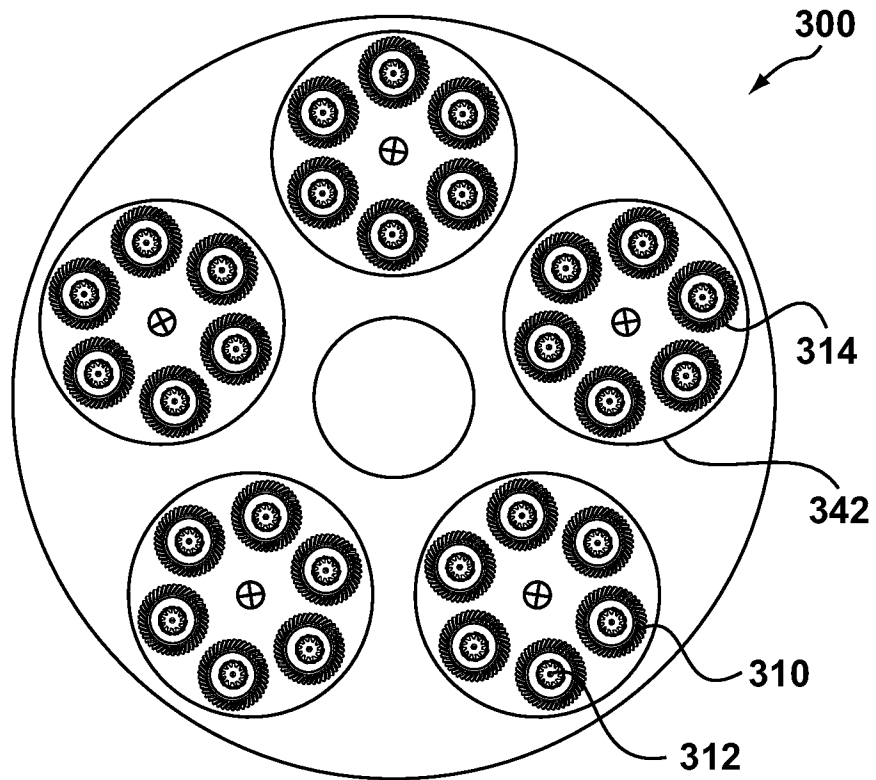
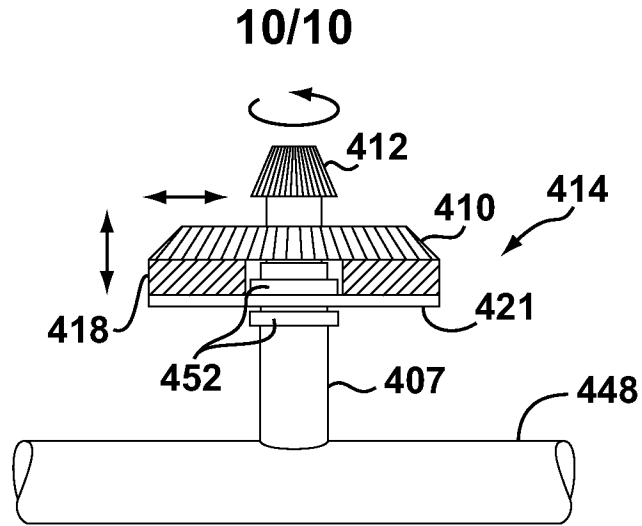
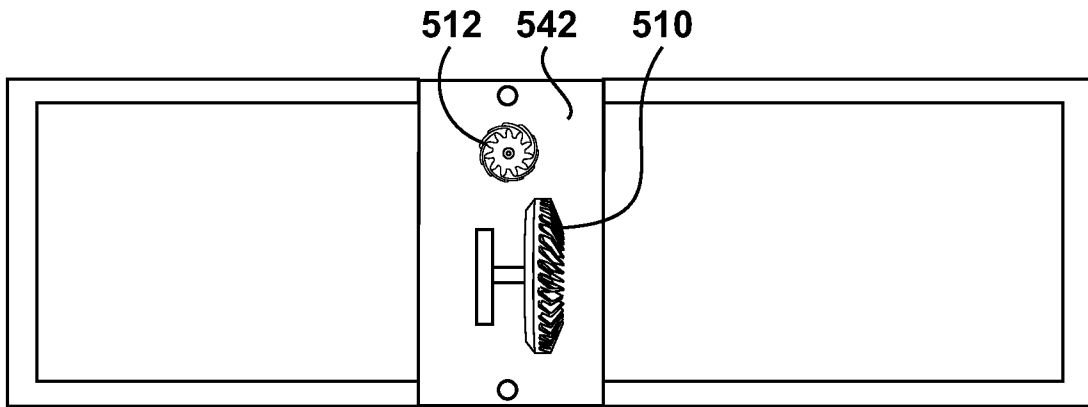


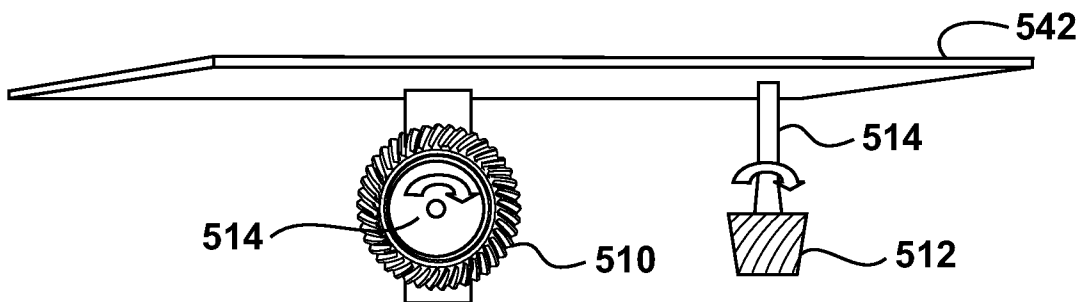
Figure 11



**Figure 12**



**Figure 13A**



**Figure 13B**

INTERNATIONAL SEARCH REPORT

International application No  
PCT/IB2010/055210

A. CLASSIFICATION OF SUBJECT MATTER  
INV. B24B31/06 B23Q3/152  
ADD.  
According to International Patent Classification (IPC) or to both national classification and IPC

B. FIELDS SEARCHED  
Minimum documentation searched (classification system followed by classification symbols)  
B24B B23Q

Documentation searched other than minimum documentation to the extent that such documents are included in the fields searched

Electronic data base consulted during the international search (name of data base and, where practical, search terms used)  
EPO-Internal

C. DOCUMENTS CONSIDERED TO BE RELEVANT

Category*	Citation of document, with indication, where appropriate, of the relevant passages	Relevant to claim No.
X	US 3 662 496 A (ALTENSTAEDTER GEORG) 16 May 1972 (1972-05-16)	1-4, 6-10, 12-14, 18,20,21
Y	column 1, line 5 - column 5, line 64; figures 1-4,8	5
X	US 3 776 827 A (INOUE K) 4 December 1973 (1973-12-04)	1-4,6-8, 10,12
Y	column 17, lines 9-28; figure 19	5
Y	US 2005/202921 A1 (GANGOPADHYAY ARUP [US] ET AL) 15 September 2005 (2005-09-15) cited in the application paragraphs [0005] - [0007]	5
	----- -/--	

Further documents are listed in the continuation of Box C.

See patent family annex.

\* Special categories of cited documents :

- "A" document defining the general state of the art which is not considered to be of particular relevance
- "E" earlier document but published on or after the international filing date
- "L" document which may throw doubts on priority claim(s) or which is cited to establish the publication date of another citation or other special reason (as specified)
- "O" document referring to an oral disclosure, use, exhibition or other means
- "P" document published prior to the international filing date but later than the priority date claimed

- "T" later document published after the international filing date or priority date and not in conflict with the application but cited to understand the principle or theory underlying the invention
- "X" document of particular relevance; the claimed invention cannot be considered novel or cannot be considered to involve an inventive step when the document is taken alone
- "Y" document of particular relevance; the claimed invention cannot be considered to involve an inventive step when the document is combined with one or more other such documents, such combination being obvious to a person skilled in the art.
- "&" document member of the same patent family

Date of the actual completion of the international search  15 March 2011	Date of mailing of the international search report  23/03/2011
Name and mailing address of the ISA/ European Patent Office, P.B. 5818 Patentlaan 2 NL - 2280 HV Rijswijk Tel. (+31-70) 340-2040, Fax: (+31-70) 340-3016	Authorized officer  Zeckau, Jochen

## INTERNATIONAL SEARCH REPORT

International application No  
PCT/IB2010/055210

C(Continuation). DOCUMENTS CONSIDERED TO BE RELEVANT		
Category*	Citation of document, with indication, where appropriate, of the relevant passages	Relevant to claim No.
X	US 6 182 954 B1 (ZHANG XUESONG [US]) 6 February 2001 (2001-02-06) column 2, line 38 - column 3, line 22 -----	13,14
X	JP 2002 239803 A (NSK LTD) 28 August 2002 (2002-08-28) * abstract; figures 1-6 -----	13,14,18

# INTERNATIONAL SEARCH REPORT

Information on patent family members

International application No

PCT/IB2010/055210

Patent document cited in search report	Publication date	Patent family member(s)	Publication date
US 3662496	A	16-05-1972	NONE
US 3776827	A	04-12-1973	NONE
US 2005202921	A1	15-09-2005	NONE
US 6182954	B1	06-02-2001	US 6267364 B1 31-07-2001
JP 2002239803	A	28-08-2002	NONE