

March 17, 1942.

F. H. NEWTON

2,276,510

VIBRATORY APPLIANCE FOR THE FEET

Filed May 26, 1939

2 Sheets-Sheet 1

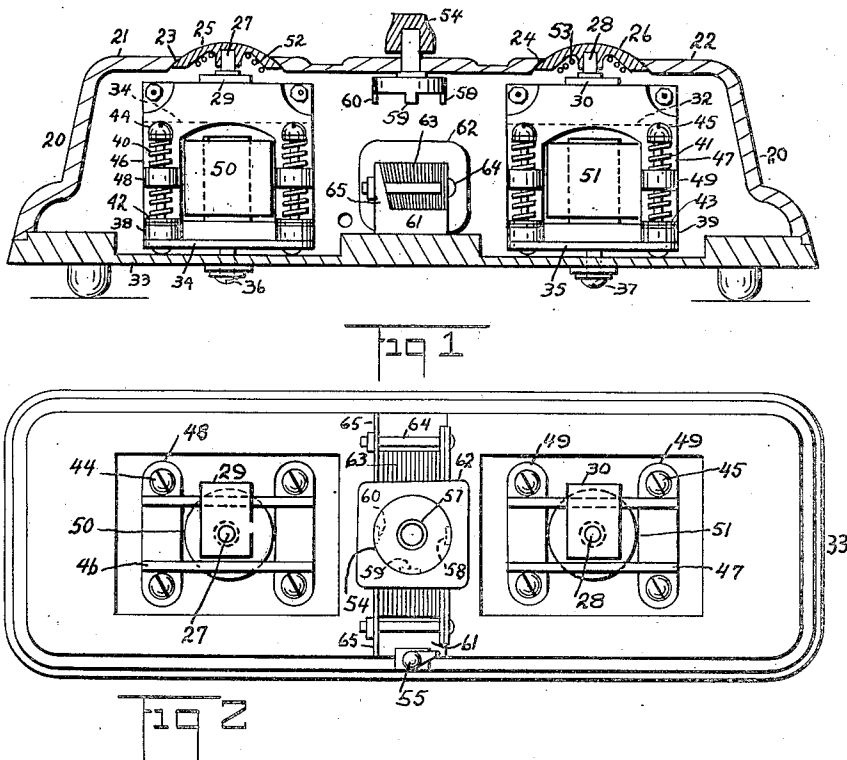

INVENTOR
Frank H. Newton

March 17, 1942.

F. H. NEWTON

2,276,510

VIBRATORY APPLIANCE FOR THE FEET

Filed May 26, 1939

2 Sheets-Sheet 2

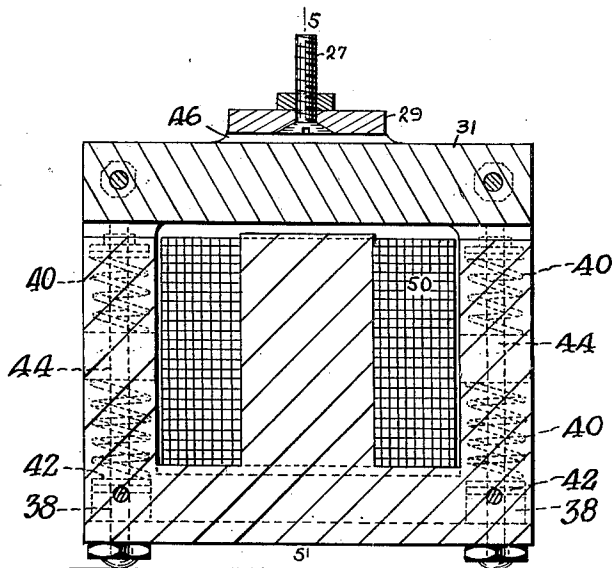

Fig 3

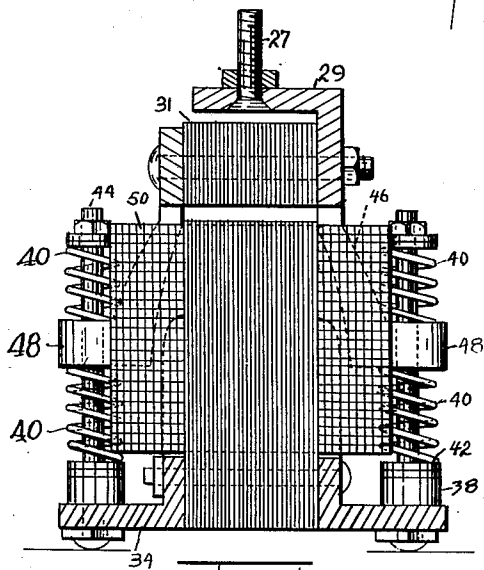

Fig 4

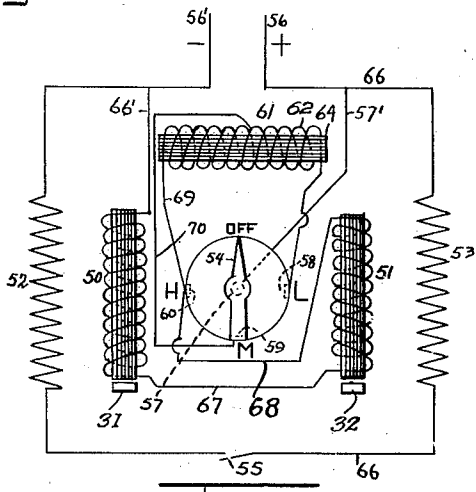

Fig 5

INVENTOR

Frank H. Newton

UNITED STATES PATENT OFFICE

2,276,510

VIBRATORY APPLIANCE FOR THE FEET

Frank H. Newton, Los Angeles, Calif.

Application May 26, 1939, Serial No. 276,003

3 Claims. (Cl. 128—41)

My invention relates to electro-therapeutic and mechanically vibratory appliance for the feet for beneficial applications thereto and more especially to a vibrator embodying a movable applicator element and electrically operated means for effecting vibration of the applicator element.

Electrically driven vibrators have long been in demonstrable and practical use as beneficial in massaging of skin tissues and corrective muscle application and treatment, and the especial objects of my invention are to introduce a technique in the treatment of foot troubles, and to promote foot health and comfort.

The principles of my improved vibrator recognizes the fact that common foot troubles are the results of poorly fitted shoes, improper weight distribution, dormant foot muscles and poor circulation. To correct these common causes of foot disorders, my invention provides a corrective therapeutic action to exercise and strengthen muscles and ligaments, stimulate normal circulation, build up the arches to accept and distribute body weight as nature designed.

My invention provides five therapeutic actions, namely: controlled vibration, soothing oscillation, gentle percussion, and penetrating healing electromagnetic waves of the infra-red ray type.

The object of my invention is to provide a therapeutic and corrective device for the human feet characterized by the provision of co-operating vibrated and unvibrated treatment surfaces, and by an improved construction for driving the vibrated surface.

Another object of my invention is to provide a corrective device for the feet which presents a smooth convex treatment surface of extended area, the control portion thereof being adapted for vibrating movement with respect to the outer portion thereof, which outer portion is non-vibratory.

Another object of my invention is to provide an electrically driven vibrator which is so formed as to render it especially applicable for use in treatment of both feet simultaneously, or one foot independently; and for these purposes having its parts so formed and arranged that the device may be supported on a floor with the vibrating elements so positioned that the soles of the feet may be readily and comfortably rested thereon for the operative treatment.

A still further object of my invention is to provide a corrective vibrator by which the feet can be simultaneously massaged, and treated with heat rays or other forms of health giving rays,

in conjunction with or independently of the vibrating action.

A still further object is to provide a duplex therapeutic vibrator equipped with co-operating vibrated and unvibrated treatment surfaces in which the vibrated treatment surfaces have components of vibration normal to said surfaces, and components of vibration that will admit of soothing oscillation, gentle percussion, soothing warmth and controlled action.

A further object is to provide a duplex corrective vibrating device which may be placed in a position to accommodate the soles of the feet in such a manner that the portion of the feet undergoing treatment may be pressed against the vibrated portions of the treatment surfaces with variability of pressures controlled by the patient.

A further object is the provision of a device for the corrective treatment of the feet which embodies vibrators having controlled oscillations, gentle percussion, and that contain electrical elements for producing health giving light rays.

A further object is to provide a foot corrective device in which the vibrator parts thereof are of extremely simplified and durable construction, and which embody electro-magnets as the vibrating means, and armatures thereof being controllable by means adjustable to vary the amplitude of their vibration.

A still further object is to provide construction in a duplex vibrator whereby parts may be economically formed and readily assembled.

It is also the object of my invention to provide certain and definite improvements over my Letters Patent Number 2,067,979 dated January 19, 1937, and my pending application Serial Number 112,187 filed November 23, 1936.

With the foregoing objects in view, together with such other objects and advantages as may appear, the invention resides in the combination, construction and arrangement of parts hereinafter described and claimed.

Reference is had to the accompanying drawings in which similar reference characters indicate similar parts wherever they may occur.

In the drawings which form a part hereof:

Figure 1 is a vertical longitudinal section of my improved electro-therapeutic and mechanically vibratory appliance for the feet, taken on the line 1—1 of Fig. 2.

Figure 2 is a top plan view of the base per se and showing the operative mechanisms mounted thereon.

Figure 3 is an enlarged vertical section taken on the line 3—3 of Figure 4.

Figure 4 is an enlarged end elevation, partly in section, of one of the vibrator mechanisms per se; and

Figure 5 is a diagram of the electric wiring.

Referring to Figure 1, 20 generally designates the duplex casing having spaced circular openings 23 and 24 in its top wall and convexed or dome-shaped vibrator elements or applicators 25 and 26 operatively mounted thereon.

The applicators 25 and 26 are removably mounted on screw studs 27 and 28 which are secured to lugs 29 and 30 secured to magnetic armature bars 31 and 32. Disposed in square shaped openings in base 33 are secondary frames 34 and 35 held in place to base 33 by screw lugs 36 and 37. Interposed between secondary frames 34 and 35 are a series of posts 38 and 39, shown as four in number to each of the secondary frames 34 and 35 and arranged at the four corners of a square.

The coil springs 40 and 41 are vertically circumferentially affixed to posts 38 and 39. The lower end portions of coil springs 40 and 41 are seated in recesses 42 and 43 formed in secondary frames 34 and 35, and the upper ends of coil springs 40 and 41 seat in recesses formed in the undersides of screws 44 and 45, affixed to posts 38 and 39.

Armature bars 31 and 32 are carried by U-shaped support members 46 and 47 secured to coil springs 40 and 41 by collars as shown at 48 and 49. Arranged within the space bounded by secondary frames 34 and 35 are electro magnets 50 and 51 extending vertically diametrically of the base of secondary frames 34 and 35.

Armature bars 31 and 32 spaced in close proximity to electro magnets 50 and 51 diametrically above thereof are adapted to be attracted by the latter upon the energization of electro magnets 50 and 51 against the opposition of coil springs 40 and 41 in such position as to limit the vibrating movements of armature bars 31 and 32 with respect to the electro magnets 50 and 51, and therefore insure the quiet operation of the device.

Arranged interiorly of the applicators 25 and 26 are electrical heat elements 52 and 53 for supplying health giving warmth to the feet resting upon the applicators. The electrical elements are comprised of coils of chromium alloy wire or any other material having a relatively high temperature co-efficient.

Referring to Figure 1, my duplex foot massaging and therapeutic device is wired with electro magnets 50 and 51 which are connected in series with a tapped inductance or choke coil which is provided with a multiple tap switch 54. This provides a selection of intensity of vibration by variation of amount of induction in series with the electro magnets 50 and 51. The heating elements 52 and 53 are connected in series with a toggle switch 55 for manual control from the top of the machine.

The toggle switch 55 is wired in shunt to the terminals of the heat elements 52 and 53, and the coils of the electro magnets 50 and 51. As here shown multiple tap switch 54 includes a stationary contact member 57 to which is connected an electrical conductor 57' of the alternating current supply.

The multiple tap switch 54 also embodies 3 terminal switch arms 58, 59 and 60, otherwise designated as "low," "medium" and "high," which said terminal switch arms are connected in series with choke or inductance coil 61. The

choke or inductance coil 61 comprises the tapped winding 62 with the conventional laminated core 63. The core 63 is preferably secured to base 33 through the agency of bolts 64 extending transversely through the core 63 at the ends thereof and respectively engaging a suitable attachment shoulder 65 forming an integral part of the iron base 33 and acts to complete the magnetic circuit of the coil 63. The shoulder 65 is centrally disposed said base between electro magnets 50 and 51 and the bolts 64 serve to both compress the core body upon itself and also to secure the core 63 to the shoulder 65.

Referring to Figure 4, I have shown diagrammatically the necessary circuits for supplying current to energize the electro magnets 50 and 51 for affecting operation of vibrating applicators 25 and 26, and heating the elements 52 and 53 for producing heat.

Alternating current supply lines 56 and 56' are adapted to be connected to stationary contact member 57 and coil winding of electro magnet 50, and from these contacts wires 66 and 67 and 57' leads to contacts 55 which is the toggle switch, and heat elements 52 and 53, and the coil winding of electro magnet 51.

From stationary contact 57 wire 57' contacts wire 68 thus connecting the circuit from supply lines 56 and 56' supplying current to electro magnets 50 and 51 and the heating elements 52, 53. In the wire 68 is interposed choke or inductance coil and also multiple tap switch 54. Wires 69, 69 and 70 are adapted to be connected to the switch arms 58, 59 and 60, respectively, and the wires 57' and 66 being connected to the terminals of the heating elements 52 and 53 and the terminals of the coils of electro magnets 50 and 51 so that the inductance coil 62 of the choke coil 61, which serves to supply current to the heating elements 52 and 53, while the multiple tap switch 54 permits regulating the power and rapidity of the vibrating elements 25 and 26 to meet the requirements of a particular treatment.

In the operation of my foot massaging and therapeutic device when it is desired to actuate the applicators 25 and 26 the multiple tap switch 54 is rotated to direct alternating electrical current through the electro magnets 50 and 51 intermittently energizing the electro magnets so as to cause the armature bars 31 and 32 to magnetically reciprocate with rapid impulses in one direction in opposition to the coil springs 40 and 41, and in the opposite direction under the resiliency of coil springs 40 and 41 in the intervals between impulses of the electro magnets 50 and 51. The power and rapidity of vibrations may be increased or decreased at the will of the operator by positioning the multiple tap switch 54 to direct current through the terminal switch arms 58, 59 and 60, otherwise designated as "low," "medium" and "high." In the treatment of the feet the device is preferably upon the floor to give the maximum of rigidity, and the soles of the feet are rested on the applicators 25 and 26.

When it is desired to effect the application of heat, the toggle switch 55 is positioned to direct current through the heating elements 52 and 53.

Heat and vibration may be affected concurrently by positioning the multiple tap switch 54 and the toggle switch 55 as indicated and shown.

Many other modifications and changes in detail will readily occur without departing from the spirit and scope of my invention as defined

in the appended claims for which I desire to secure by Letters Patent.

What I claim:

1. In an appliance of the character described, a base, an electromagnet disposed centrally on said base, rods extending from said base at opposite sides of said electromagnet, angled members slidably engaged with said rods and supporting the armature of the electromagnet in its operative relation thereto, coiled springs on said rods at opposite sides of the engaged portions of said angled members, one of said angled members having a part overlying said armature, and a vibrator applicator support extending from said angled member part.

2. In an appliance of the character described, a base, an electromagnet disposed centrally on said base, rods rising from said base at opposite sides of said electromagnet, angled supports slidably engaged with said rods, opposed springs on said rods above and below the

engaged portions of said supports, an armature secured between portions of said supports and overlying said electromagnet, one of said supports having an angled part overlying said armature, and a vibrator applicator support rising from said angled part.

3. In an appliance of the character described, a casing having an opening, a base within said casing, an electromagnet disposed centrally on said base, rods rising from said base at opposite sides of said electromagnet, angled supports slidably engaged with said rods, opposed springs on said rods above and below the engaged portions of said supports, an armature secured between other portions of said supports and overlying said electromagnet, one of said supports having an angled part overlying said armature, a member rising from said angled part, and a vibrator applicator detachably mounted on said member and operable therewith through said casing opening.

FRANK H. NEWTON.