

(19) World Intellectual Property Organization  
International Bureau



(43) International Publication Date  
15 February 2007 (15.02.2007)

PCT

(10) International Publication Number  
**WO 2007/018383 A1**

- (51) International Patent Classification:  
*H04N 5/44* (2006.01)
- (21) International Application Number:  
PCT/KR2006/003081
- (22) International Filing Date: 4 August 2006 (04.08.2006)
- (25) Filing Language: English
- (26) Publication Language: English
- (30) Priority Data:  
60/705,491 5 August 2005 (05.08.2005) US  
60/789,577 6 April 2006 (06.04.2006) US  
60/812,090 9 June 2006 (09.06.2006) US  
10-2006-0073119 2 August 2006 (02.08.2006) KR
- (71) Applicant: SAMSUNG ELECTRONICS CO., LTD.  
[KR/KR]; 416 Matan-dong, Yeongtong-gu, Suwon-si,  
Gyeonggi-do 442-742 (KR).
- (72) Inventors: LEE, Jong-Ho; 102-701 Lotte Castle Em-  
pire, Yeouido-dong, Yeongdeungpo-gu, Seoul 150-936  
(KR). LEE, Kwang-Kee; 201-1702 Ssangyong Apt.,  
Garak 2-dong, Songpa-gu, Seoul 138-747 (KR). JUNG,  
Un-Gyo; 106-1003 Pungseong Sinmiju Apt., 895

Gian-dong, Hwaseong-si, Gyeonggi-do 445-777 (KR).  
**ADAMS, Glenn, A.**; 114 Mount Auburn Street, 4th Floor,  
Cambridge, MA 02138 (US).

- (74) Agents: **KIM, Dong-Jin** et al.; 6th Fl. Youngpoong Bldg.,  
142, Nonhyun-dong, Gangnam-gu, Seoul 135-749 (KR).
- (81) Designated States (*unless otherwise indicated, for every  
kind of national protection available*): AE, AG, AL, AM,  
AT, AU, AZ, BA, BB, BG, BR, BW, BY, BZ, CA, CH, CN,  
CO, CR, CU, CZ, DE, DK, DM, DZ, EC, EE, EG, ES, FI,  
GB, GD, GE, GH, GM, HN, HR, HU, ID, IL, IN, IS, JP,  
KE, KG, KM, KN, KP, KZ, LA, LC, LK, LR, LS, LT, LU,  
LV, LY, MA, MD, MG, MK, MN, MW, MX, MZ, NA, NG,  
NI, NO, NZ, OM, PG, PH, PL, PT, RO, RS, RU, SC, SD,  
SE, SG, SK, SL, SM, SY, TJ, TM, TN, TR, TT, TZ, UA,  
UG, UZ, VC, VN, ZA, ZM, ZW.
- (84) Designated States (*unless otherwise indicated, for every  
kind of regional protection available*): ARIPO (BW, GH,  
GM, KE, LS, MW, MZ, NA, SD, SL, SZ, TZ, UG, ZM,  
ZW), Eurasian (AM, AZ, BY, KG, KZ, MD, RU, TJ, TM),  
European (AT, BE, BG, CH, CY, CZ, DE, DK, EE, ES, FI,  
FR, GB, GR, HU, IE, IS, IT, LT, LU, LV, MC, NL, PL, PT,  
RO, SE, SI, SK, TR), OAPI (BF, BJ, CF, CG, CI, CM, GA,  
GN, GQ, GW, ML, MR, NE, SN, TD, TG).

[Continued on next page]

(54) Title: APPARATUS FOR PROVIDING MULTIPLE SCREENS AND METHOD OF DYNAMICALLY CONFIGURING MULTIPLE SCREENS

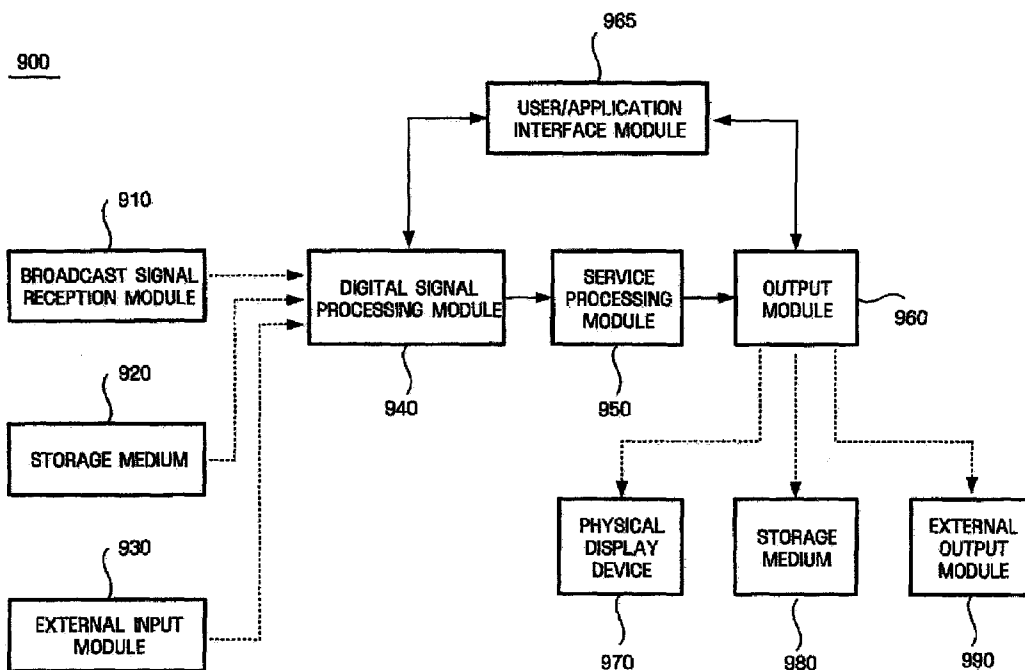

(57) Abstract: An apparatus for providing multiple screens and a method of dynamically configuring multiple screens are provided. The apparatus for providing multiple screens includes a service processing module which generates logical screens displaying services and a display screen and swaps the services between the logical screens, and an output module which maps the logical screens to arbitrary locations on the display screen.

WO 2007/018383 A1



**Published:**

- with international search report
- before the expiration of the time limit for amending the claims and to be republished in the event of receipt of amendments

*For two-letter codes and other abbreviations, refer to the "Guidance Notes on Codes and Abbreviations" appearing at the beginning of each regular issue of the PCT Gazette.*

## Description

# APPARATUS FOR PROVIDING MULTIPLE SCREENS AND METHOD OF DYNAMICALLY CONFIGURING MULTIPLE SCREENS

### Technical Field

- [1] Apparatuses and methods consistent with the present invention relate to configuring multiple screens, and more particularly, to dynamically configuring multiple screens which provide multiple contents on a single physical display device.

### Background Art

- [2] Related art broadcast receivers such as digital televisions (TVs) or digital set-top boxes provide only one content element on a single physical display device or simultaneously display a main screen and a sub-screen on a single physical display device.
- [3] Even though related art broadcast receivers can simultaneously display both the main screen and the sub-screen on the same display screen, they can only arrange the main screen and the sub-screen in a limited number of manners. In the case of a content displayed within the main screen, all elements of the content, i.e., video data, audio data, and other data, are displayed. On the other hand, in the case of a content displayed within the sub-screen, only some of the elements of the content are displayed.
- [4] Content sources include a broadcast service such as a satellite broadcaster, a terrestrial broadcaster, or a cable broadcaster, a storage medium such as digital versatile discs (DVDs), or an external device connected to an input terminal. However, it is quite difficult to display contents provided by such various content sources on a display screen using the existing broadcast receivers.
- [5] In an interactive TV application program environment such as the Multimedia Home Platform (MHP), the Advanced Common Application (ACAP), and the Open Cable Application Platform (OCAP), it is assumed that only one screen is output on a physical display device.
- [6] In the interactive TV application program environment, for example, a Home Audio/Video Interoperability (HAVi)-based user interface (UI) is adopted. According to the HAVi UI standard, even though no restriction is imposed on the number of screens displayed on a physical display device, only one screen is generally displayed on a physical display device.

### Disclosure of Invention

#### Technical Problem

- [7] In such an environment, it is difficult to perform operations, such as decoding,

digital signal processing, user interaction processing, etc. with respect to one among multimedia contents displayed on a screen while displaying the multimedia contents on independent screens. In addition, it is also difficult to dynamically control the life cycles of application programs and the use of resources in the units of the screens.

[8] Accordingly, there exists a need for a method of displaying a variety of contents on a dynamically configured screen.

### **Technical Solution**

[9] The present invention provides an apparatus and method for dynamically configuring multiple screens which provide a plurality of contents on a physical display device.

[10] According to an aspect of the present invention, there is provided an apparatus for providing multiple screens, the apparatus including a service processing module which generates logical screens displaying services and a display screen and swaps the services between the logical screens, and an output module which maps the logical screens to arbitrary locations on the display screen.

[11] According to another aspect of the present invention, there is provided a method of dynamically configuring multiple screens, the method including generating logical screens displaying services and a display screen, mapping the logical screens to arbitrary locations on the display screen, and swapping the services between the logical screens.

### **Description of Drawings**

[12] The above and other aspects of the present invention will become more apparent by describing in detail exemplary embodiments thereof with reference to the attached drawings, in which:

[13] FIGS. 1A to 1H are diagrams illustrating a configuration of a PIP screen according to an exemplary embodiment of the present invention;

[14] FIG. 2 is a diagram illustrating the relationship between a logical screen and a display screen according to an exemplary embodiment of the present invention;

[15] FIGS. 3A to 3E are diagrams illustrating a configuration of a screen including a mapper according to an exemplary embodiment of the present invention;

[16] FIG. 4 is a block diagram illustrating service sources according to an exemplary embodiment of the present invention;

[17] FIGS. 5A and 5B are diagrams illustrating a non-abstract service and an abstract service according to an exemplary embodiment of the present invention;

[18] FIG. 6 is a diagram illustrating attribute information and interfaces of a logical screen and a display screen;

[19] FIG. 7 is a diagram illustrating an attribute 'z-order' of a logical screen according to

an exemplary embodiment of the present invention;

[20] FIGS. 8A and 8B are diagrams each illustrating an attribute 'Display\_Area' of a logical screen according to exemplary embodiments of the present invention;

[21] FIG. 9 is a diagram illustrating a method of mapping two services to a display screen according to an exemplary embodiment of the present invention;

[22] FIG. 10 is a diagram illustrating processes of swapping services according to an exemplary embodiment of the present invention;

[23] FIG. 11 is a block diagram illustrating a configuration of an apparatus for providing multiple screens according to an exemplary embodiment of the present invention;

[24] FIG. 12 is a flowchart illustrating a method of dynamically configuring multiple screens according to an exemplary embodiment of the present invention;

[25] FIG. 13 is a diagram illustrating a process of service swapping according to an exemplary embodiment of the present invention;

[26] FIG. 14 is a diagram illustrating a software architecture for providing multiple screens according to an exemplary embodiment of the present invention;

[27] FIG. 15 is a diagram illustrating the relationships among modules constituting an application programming interface (API) layer according to an exemplary embodiment of the present invention;

[28] FIG. 16 is a flowchart illustrating a method of displaying a plurality of services that are displayed on respective corresponding logical screens on a display screen by the modules illustrated in FIG. 15 according to an exemplary embodiment of the present invention; and

[29] FIG. 17 is a flowchart illustrating a method of swapping services displayed on logical screens between the modules illustrated in FIG. 15 according to an exemplary embodiment of the present invention.

### **Mode for Invention**

[30] Advantages and features of the present invention and methods of accomplishing the same may be understood more readily by reference to the following detailed description of exemplary embodiments and the accompanying drawings. The present invention may, however, be embodied in many different forms and should not be construed as being limited to the exemplary embodiments set forth herein. Rather, these exemplary embodiments are provided so that this disclosure will be thorough and complete and will fully convey the concept of the invention to those skilled in the art, and the present invention will only be defined by the appended claims. Like reference numerals refer to like elements throughout the specification.

[31] Before explaining the present invention, terms used in the specification will now be described briefly. However, it is noted that the use of any and all examples or exemplary terms provided herein is intended merely to better illuminate the invention

and is not a limitation on the scope of the invention unless otherwise claimed.

- [32] The term 'service' indicates a group of multimedia contents displayed together, i.e., at least one of service components forms a single service.
- [33] Service components are elements of a service and include a video component, an audio component, and a data component. The video component and the audio component include video information and audio information, respectively. Further, the data component refers an application in a service and includes an application providing weather information, an application providing stock information, an application providing subtitles or an electronic program guide (EPG).
- [34] The term 'service context' indicates an object which can control the executing of a service and includes various resources, devices, and execution state information needed for providing a service. It is possible to confirm the service components that are configuration elements of the service by the service context.
- [35] The term 'physical display device' indicates a physical device which actually displays the content of a service, an external output port to which the content is output, or a storage device in which the content is stored.
- [36] The term 'display screen' indicates a screen actually displayed on a physical display device. An arbitrary service may be directly set in the display screen, and the display screen may be displayed on a physical display device. Alternatively, at least one logical screen which is mapped to a certain area of the display screen may be displayed on the physical display device.
- [37] The term 'logical screen' indicates a space in which an arbitrary service is displayed. A logical screen is a virtual screen before being mapped to a display screen and thus is not displayed on a physical display device. Therefore, the logical screen is mapped to the display screen to be displayed on the physical display device.
- [38] The logical screen and the display screen may be a combination of a background still image, a video raster, and a graphic raster. The graphic raster may be a combination of text, lines, colors, and images or a mixture of video frames.
- [39] The term 'main service' indicates a service that is selected as a main service through a menu displayed on the physical display device or a remote controller by a user or through an API by an application, and the screen on which the main service is displayed is referred to as a 'main screen'.
- [40] The term 'Picture-in-Picture service' (PIP service) indicates a service that is selected as a sub-service in the main service through a menu displayed on a physical display device or a remote controller by a user via an API by an application, and the PIP service may be displayed on a picture-in-picture screen (PIP screen) or a main screen.
- [41] The PIP screen includes a screen that occupies a part of another screen as illustrated in FIGS. 1A to 1D and a screen that is simultaneously displayed with another screen

without overlapping the other screen as illustrated in FIGS. 1E to 1F. In this case, it is understood that the PIP screen may include a screen that is displayed on an arbitrary location or area in the physical display device or overlaps another screen, as illustrated in FIGS. 1G and 1H.

[42] The terms that have not been described in the foregoing description will be described as necessary. Hereinafter, exemplary embodiments will be described in detail with reference to accompanying drawings.

[43] FIG. 2 is a diagram illustrating the relationship between a logical screen and a display screen according to an exemplary embodiment of the present invention.

[44] Referring to FIG. 2, a service may be displayed using logical screens 210, 212, and 214. The logical screens 210, 212, and 214 are mapped to display screens 220, 222, and 224 through a mapping block 230.

[45] In detail, the logical screens 210 and 212 are mapped to the display screen 220, the logical screens 212 and 214 are mapped to the display screen 222, and the logical screens 210, 212, and 214 are mapped to the display screen 224.

[46] In short, at least one logical screen which displays a service is mapped to an arbitrary area of a display screen by the mapping block 230.

[47] The mapping block 230 is a group of various pieces of information needed for mapping a logical screen to a display screen. Examples of the various pieces of information include coordinate information of a predetermined area on a display screen to which each of a plurality of logical screens is mapped, identification information of the logical screens and the display screen, and information specifying in what order the logical screens are displayed on the display screen.

[48] The mapping block 230 can change the size of the logical screen so to be allocated in an arbitrary area of the display screen. That is, the mapping block 230 can perform scaling of the logical screen and allocating of the position thereof, and FIGS. 3A to 3E are diagrams illustrating a configuration of the screen including a mapper as the mapping block.

[49] Referring to FIG. 3A, the main screen including a combination of a background still image B, a video raster V, and a graphic raster G is mapped to the entire display screen by a mapper with a normal size. The PIP screen including only video components is mapped to the entire display screen by the mapper with a reduced size. In this case, the mapped PIP screen is displayed on the main screen, which is determined depending on a Z value. The reference character Z refers to z-order value which will be described later. An overlay screen may be combined with the display screen. The overlay screen is a specific screen disposed at the outmost side, and may be used when providing a caption function. The PIP screen may have only a video component as illustrated in FIG. 3A, or may have a combination of the background still image B, the video raster

V, and the graphic raster G as illustrated in FIG. 3B.

[50] Referring to FIG. 3C, the main screen including the combination of the background still image B, the video raster V, and the graphic raster G is mapped to the entire display screen by the mapper with a normal size. Two PIP screens #1 and #2 having only video component is mapped to an arbitrary area of the display screen by the mapper with a reduced size. In this case, the mapped PIP screen is disposed on the main screen and the Z value can be constantly maintained. Further, the overlay screen may be combined with the display screen. The configuration of the screen may have a plurality of PIP screens including only video components as illustrated in FIG. 3C or a plurality of PIP screens including a combination of the background still image B, the video raster V, and the graphic raster G as shown in FIG. 3D.

[51] Picture-Outside-Picture (POP) screens are illustrated in FIG. 3E. It can be understood that the PIP screen is displayed inside the main screen and the POP screen is displayed outside the main screen. Referring to FIG. 3E, the plurality of PIP screens #1 and #2 including a combination of the background still image B, the video raster V, and the graphic raster G are mapped to arbitrary areas of the display screen by the mapper with a reduced size. In this case, the Z value of the mapped POP screens #1 and #2 may be constantly maintained. Further, the overlay screen may be combined with the display screen.

[52] The mapping block 230 may be realized by interfaces or functions prepared by various computer program languages to be executed and create or change the relationship between the logical screen and the display screen by using the above information as parameters.

[53] The mapping block 230 may also be realized by a hardware in order to function for mapping the logical screen to the display screen

[54] Further, services provided by various service sources may be displayed on a display screen, and the display screen may be displayed on a physical display device, as illustrated in FIG. 4.

[55] There are service sources which provide broadcast services such as a terrestrial broadcaster 320 and a cable broadcaster 330, service sources which provide services stored in a storage medium such as a personal video recorder (PVR) 340, and service sources (not illustrated in FIG. 4) which provide services via a wired network or a wireless network.

[56] A broadcast receiver 310 receives services from the service sources and produces logical screens displaying each of the received services.

[57] Then, an arbitrary service is directly set on the display screen to be displayed on a physical display device using a predefined method or a method set by a user or an application. Otherwise, at least one logical screen that is mapped to an arbitrary area on

the display screen is displayed on a physical display device 350. In short, services provided by the terrestrial broadcaster 320, the cable broadcaster 330, and the PVR are displayed on the physical display device 350.

[58] The terrestrial broadcaster 320, the cable broadcaster 330, and the PVR 340 are illustrated in FIG. 4 as being service sources, but the present invention is not limited to it. Any type of multimedia content source which provides multimedia contents that can be displayed together can be a service source according to an exemplary embodiment of the present invention.

[59] Services according to an exemplary embodiment of the present invention can be classified into abstract services and non-abstract services, as illustrated in FIGS. 5A and 5B.

[60] The abstract services are not services provided by broadcast signals transmitted in real time but services independent of broadcast channels. The abstract services include only data components, i.e., application, without video components and audio components. Examples of the abstract services include services having unbound applications based on the OCAP standard.

[61] The non-abstract services are understood as services other than abstract services.

[62] According to the current exemplary embodiment of the present invention, both abstract services and non-abstract services have independency. For example, abstract services may be directly set on the physical display device not through logical screens and non-abstract services may be displayed on the logical screens. Then, the logical screens may be mapped to the display screen in which the abstract services are set. Thereafter, the display screen may be output through the physical display device. By doing so, the abstract services can be displayed on the display screen independently of the non-abstract services. In addition, the abstract services and non-abstract services may be mapped to different logical screens. Thereafter, the logical screens may be mapped to a single display screen. In other words, the abstract services can be displayed on the display screen independently of non-abstract services.

[63] According to the current exemplary embodiment of the present invention, the logical screen and the display screen may be categorized as being different objects. Alternatively, a screen may serve as a logic screen or a display screen according to attribute information of one screen object.

[64] That is, it is possible to confirm whether the screen is a logical screen or a display screen, on the basis of type information among attribute information of the screen object.

[65] The attribute information of the screen object includes a plurality of attributes 'z-Order', 'Display\_Area', 'Visibility', 'Associated\_Display\_Screen', 'Associated\_Service\_Contexts', and 'OutputPort'.

- [66] FIG. 6 illustrates the attribute information of the screen object and the type of interfaces that process the attribute information.
- [67] An attribute 'type' 505 is attribute information indicating whether the screen is a logical screen or a display screen.
- [68] An attribute 'z-Order' 510 is for determining in what order a plurality of logical screens are arranged along the z-axis. FIG. 7 illustrates a configuration of logical screens on a physical display device for a combination of the values of attributes 'z-Order' of the logical screens.
- [69] Referring to FIG. 7, first and second logical screens 620 and 630 are respectively mapped to predetermined areas of a display screen 610. In detail, the first logical screen 620 is displayed on the display screen 610, and the second logical screen 630 is displayed on the display screen partially overlapping the first logical screen 620. In other words, the display screen 610, the first logical screen 620, and the second logical screen 630 are sequentially arranged in the direction of the z-axis. In this case, an attribute 'z-Order' of the first logical screen 620 may be set to a value of 1, and an attribute 'z-Order' of the second logical screen 630 may be set to a value of 2. The attributes 'z-Order' of the first and second logical screens 620 and 630 may be set to any numbers or characters as long as they can represent a certain order in which the first and second logical screens 620 and 630 are to be arranged along the z-axis.
- [70] An attribute 'Display\_Area' 520 is information regarding a display screen area of a logical screen, as to be illustrated in FIGS. 8A and 8B.
- [71] FIG. 8A illustrates that a logical screen 710 is mapped to an entire area of the display screen 720, and FIG. 8B illustrates that a logical screen 730 is mapped to a partial area of the display screen 740.
- [72] The attribute 'Display\_Area' may include information specifying the two-dimensional coordinates of a predetermined portion of a display screen to which the logical screen is to be mapped or may include information specifying a predetermined location on the display screen and an offset value indicating how much the logical screen deviates from the predetermined location on the display screen.
- [73] An attribute 'Visibility' 530 determines whether a logical screen is to be visibly or invisibly displayed on a display screen. It is possible to make a logical screen appear on or disappear from a display screen by altering the value of the attribute 'Visibility' 530.
- [74] An attribute 'Associated\_Display\_Screen' 540 is information regarding display screens associated with a logical screen. A logical screen which is not associated with any display screens may not be displayed on a physical display device nor be transmitted to external output devices.
- [75] An attribute 'Associated\_Service\_Contexts' 550 is information regarding service

contexts connected to a logical screen or a display screen. Services set in such service contexts may be displayed on a logical screen or a display screen.

[76] An attribute 'OutputPort' 560 is information regarding devices by which a display screen is to be output, and such devices include display screens, wired/wireless communication media, and various storage media.

[77] Interfaces for identifying or altering the values of the attributes illustrated in FIG. 6 may be provided. Referring to FIG. 6, the interfaces may include an interface 'SET' for setting attribute values or connecting a logical screen to a display screen, an interface 'ADD' for adding attribute values or connecting a logical screen to a service, an interface 'GET' for identifying attribute values, and an interface 'REMOVE' for deleting attribute values. These interfaces may include processes, functions, procedures, or methods that perform their functions, respectively.

[78] For example, a method 'getDisplayScreen(void)' returns a display screen associated with the current screen. In detail, if the current screen is a logical screen, the method 'getDisplayScreen(void)' returns the associated display screen. If the current screen is display screen, the method 'getDisplayScreen(void)' returns reference information regarding the current screen. Further, if the current screen is a logical screen, but there is no associated screen, the method 'getDisplayScreen(void)' returns a value of 'NULL'.

[79] According to another example, a method 'public void setDisplayArea(HScreenRectangle rect) throws SecurityException, IllegalStateException' provides a function for mapping the current logical screen to a predetermined area of the associated display screen. An instance that is provided as a parameter is of a class 'HScreenRectangle' of a package 'org.havi.ui', and has two-dimensional position information. The execution of the methods 'SecurityException' and 'IllegalStateException' may be conducted as an exceptional operation for the method 'setDisplayScreen(HScreen screen)'. The method 'IllegalStateException' may be executed when the current screen is a logical screen or when a portion of a display screen associated with a current logical screen cannot change due to the characteristics of a host platform.

[80] According to still another example, a method 'getDisplayArea(void)' returns regional information of a current screen as HScreenRectangle information. If the current screen corresponds to a display screen, the method 'getDisplayArea(void)' returns HScreenRectangle information having the same value as HScreenRectangle (0,0,1,1). If the current screen is a logical screen, the method 'getDisplayArea(void)' returns information regarding an area on a display screen occupied by the current screen. If the current screen is a logical screen but is not associated with any display screen, the method 'getDisplayArea(void)' returns a value 'NULL'.

[81] Certain terms are used throughout the following description to refer to particular

interfaces. However, one skilled in the art will appreciate that a particular function is named simply to indicate its functionality. This detailed description of the exemplary embodiments does not intend to distinguish between functions that differ in name but not function.

- [82] FIG. 9 is a diagram illustrating a process that two services are set on two logical screens to be mapped to a single display screen.
- [83] Referring to FIG. 9, a first service includes all the three service components, i.e., video, audio, and data components, and a second service includes only video and audio components. However, the present invention does not impose any restrictions on service components, and the first and second services illustrated in FIG. 8 are exemplary.
- [84] As illustrated in FIG. 9, the first and second services are displayed on a physical display device in almost the same manner as in the related art. According to the current exemplary embodiment of the present invention, it is possible to display a plurality of services on a physical display device independently of one another without imposing any restrictions on the number of services that can be displayed on a single display screen.
- [85] By associating the service context for a service with a screen, contents in the service can be displayed, and service contexts can be swapped or interchanged between screens according to a selection of a user or an application. The operation of swapping the service contexts between the screens refers to service swapping. A service context used in the service swapping may be for an abstract service or non-abstract service.
- [86] The service swapping can be performed using interfaces 'add' and 'remove' described with reference to FIG. 6. More specifically, an operation of associating the service contexts with screens is performed through a method 'addServiceContext', and an operation of canceling the association between the service context and the screen is performed through a method 'removeServiceContext'. That is, in order for service swapping, a service context to be swapped is separated from the screens that are an object for service swapping in advance. Therefore, the method 'removeServiceContext' is used. And then, the separated service contexts are associated with corresponding screens using a method 'addServiceContext'.
- [87] In an exemplary embodiment of the present invention, as described above, a method 'swapServiceContexts' or a method 'swapMultiScreenContexts' that swaps service contexts between specific screens can be used.
- [88] A process of service swapping according to an exemplary embodiment of the present invention is illustrated in FIG. 10. It is assumed that a main screen 10 and a PIP screen 20 are associated with a first service 12 and a second service 22, respectively (refer to (A) in FIG. 10). In this state, when a user or an application requests

a service swapping, the first service 12 is disconnected from the main screen 10 and the second service 22 is disconnected from the PIP screen 20 (refer to (B) in FIG. 10). Thereafter, the second service 22 is connected to the main screen 10 and the first service is connected to the PIP screen 20 (refer to (C) FIG. 10).

[89] As illustrated in FIG. 10, when the services are swapped between the main screen 10 and the PIP screen 20, it is necessary to check whether an application performed in the main screen 10 can be performed in the PIP screen 20.

[90] It is possible to check whether an application performed in the main screen 10 can be performed in the PIP screen on the basis of signal information. The signal information can be included in application information indicating information for applications in the services. Examples of the application information include an application information table (AIT) based on the MHP standard and an eXtended application information table (XAIT) based on the OCAP standard. The signal information may be provided by a service provider (for example, broadcasting system providing terrestrial broadcasts 320 or cable broadcasts 330 of FIG. 4).

[91] If the application 14 performed in the main screen 10 cannot be performed in the PIP screen 20, the application 14 is interrupted. The interruption may include suspension, i.e., the application 14 is temporally suspended, and termination, i.e., the application 14 is completely terminated. Therefore, the application may be suspended or terminated. In this case, the type of interruption of the application 14 is varied according to realized examples.

[92] When the service swapping is re-accomplished between the main screen 10 and the PIP screen 20 so that the application 14 is reconnected to the main screen 10, the application 14 can be re-executed. In this case, when the application 14 is in a suspension state, the application 14 that is reconnected to the main screen 10 is resumed. When the application 14 is in a terminated state, the application 14 connected to the main screen 10 is restarted.

[93] In FIG. 10, even though the service swapping process between the main screen 10 and the PIP screen 20 is illustrated, this invention is not limited thereto. Further, the service swapping process can be applied between two or more screens according to an exemplary embodiment. Furthermore, in FIG. 10, the entire service connected to the screen is swapped. However, a part of service contexts can be swapped between the screens.

[94] FIG. 11 is a block diagram of an apparatus for providing multiple screens according to an exemplary embodiment of the present invention.

[95] Referring to FIG. 11, an apparatus 900 for providing multiple screens includes a digital signal processing module 940, a service processing module 950, an output module 960, and a user/application interface module 965.

[96] Also, the apparatus 900 includes a broadcast signal reception module 910, a storage medium 920, and an external input module 930 as service sources, and includes a physical display device 970, a storage medium 980, and an external output module 990 as service output media.

[97] The term 'module', as used herein, means, but is not limited to, a software or hardware component, such as a Field Programmable Gate Array (FPGA) or an Application Specific Integrated Circuit (ASIC), which performs certain tasks. A module may advantageously be configured to reside on the addressable storage medium and configured to be executed on one or more processors. Thus, a module may include, by way of example, components, such as software components, object-oriented software components, class components and task components, processes, functions, attributes, procedures, subroutines, segments of program code, drivers, firmware, microcode, circuitry, data, databases, data structures, tables, arrays, and variables. The functionality provided for in the components and modules may be combined into fewer components and modules or further separated into additional components and modules.

[98] The digital signal processing module 940 receives various information of a service such as a multimedia content, e.g., video information, audio information, or data information, from the broadcast signal reception module 910, the storage medium 920, or the external input module 930.

[99] The broadcast signal reception module 910 receives a satellite, terrestrial, or cable broadcast signal and transmits the received broadcast signal, the storage medium 920 stores video information, audio information, or data information of a service, and the external input module 930 receives video information, audio information, or data information of a service from an external device such as a network interface module connected to a network.

[100] The digital signal processing module 940 restores a plurality of services using received service components. The restored services include abstract or non-abstract services.

[101] Here, the phrase 'a plurality of services' refers to two or more services transmitted by the broadcast signal reception module 910 or two or more services respectively transmitted by the broadcast signal reception module 910 and the storage medium 920.

[102] The digital signal processing module 940 may restore services according to selection by a user or an application with the aid of the user/application interface module 965. In this case, the user or the application may select the connection between an arbitrary service and a screen.

[103] The service processing module 950 generates a logical screen and a display screen to display a service restored by the digital signal processing module 940. The service processing module 950 connects the services to the logical screens. Further, the service

restored by the digital signal processing module 940 may be not connected to the logical screens in the service processing module 950, but may be directly connected to the display screen.

[104] Further, the service processing module 950 may perform service swapping between the screens in response to the request of a user or an application through the user/application interface module 965.

[105] The output module 960 maps one or more logical screens produced by the service processing module 950 to the display screen. For example, the output module 960 may serve as the mapping block 230 illustrated in FIG. 2. The mapping area of the logical screens to the display screen may be previously set using a predefined method or a method set by the user with the aid of the user/application interface module 965.

[106] A display screen provided by the output module 960 may be displayed on the physical display device 970 or may be stored in the storage medium 980. Examples of the storage medium 980 include computer readable floppy discs, hard discs, CD-ROM, DVD, DVD-ROM, BD (Blu-ray Disc), and semiconductor memories.

[107] Also, a display screen provided by the output module 960 may be transmitted to an external device connected to a network via the external output module 990.

[108] For this, the output module 960 may include a plurality of output ports via which a display screen can be provided. In this case, a display screen can be provided via an output port set in advance as a default or an output port chosen by the user with the aid of the user/application interface module 965.

[109] The user or the application can choose one of a plurality of services or restore desired services using the user/application interface module 965. Also, the user can choose one of a plurality of display screens using the user/application interface module 965.

[110] Since the modules illustrated in FIG. 11 are divided according to their functions, it is possible to be connected to the other modules.

[111] FIG. 12 is a flowchart illustrating a method of dynamically configuring multiple screens according to an exemplary embodiment of the present invention.

[112] In general, video information, audio information, and data information constituting a multimedia content are transmitted in a predetermined format, for example, an MPEG stream format. In operation S1010, an apparatus for providing a service such as a multimedia content service receives video information, audio information, and data information and restores a service based on the video information, the audio information, and the data information. Here, the service restored in operation S1010 may be selected or previously determined by a user or an application. The user may use a menu displayed on the display device or a remote controller to select the connections between an arbitrary screen and a screen. The application may select the connections

using an API.

[113] Further, data information includes application information regarding application for a service, and these application information includes signal information indicating whether the application can be executed on a PIP screen. Examples of the application information include an AIT based on the MHP standard and an XAIT based on the OCAP standard. The signal information may be added to the application information.

[114] Thereafter, in operation S1020, the restored service is set such that it can be displayed on a logical screen. In operation S1030, the logical screen is mapped to a display screen. In operation S1040, the display screen is provided to the user using a display screen, a storage medium, or a network.

[115] The restored service is illustrated in FIG. 12 as being displayed on a physical display device via a logical screen. However, the restored service may be directly displayed on a physical display device without passing through the logical screen.

[116] When the user selects the PIP service, the PIP service is realized in two modes. In the first mode, only video component for PIP service selected on the main screen is provided without creating a separate logical screen for PIP service, that is, PIP screen. In the second mode, a separate logical screen for PIP service is created to provide the PIP service selected on the created PIP screen.

[117] FIG. 12 illustrates a method of mapping only one service to a display screen for simplicity. However, a plurality of services may be mapped to a display screen with or without passing through a plurality of logical screens.

[118] When a display screen is provided to the user in this manner, the user or the application can perform a plurality of services.

[119] As illustrated in FIG. 12, when the services are displayed on the screens, the service swapping is performed between the screens in response to the request of the user or the application.

[120] FIG. 13 is a diagram illustrating a process of swapping services according to an exemplary embodiment of the present invention.

[121] In operation S1110, a request for service swapping is input through the user/application interface module 965 by the user or an application, and in operation 1120, the service processing module 950 disconnects from the screens the services that are displayed on screens and are an object of the service swapping.

[122] Thereafter, in operation 1130, the service processing module 950 determines that an application included in a service to be connected to a PIP screen can be executed on a PIP screen before connecting the disconnected services to corresponding screens. However, if the application is not included in the service to be connected, the services are directly connected to the screens.

[123] If the application included in the service to be connected can be executed on the

PIP screen, the service processing module connects the services in operation 1150. On the other hand, if the application cannot be executed on the PIP screen, the service processing module 950 suspends the execution of the application and connects the services to the corresponding screens in operation 1140. However, the service displayed on the PIP screen can be connected to the main screen regardless of the application.

[124] Hereinafter, this invention will be described from the view point of a software architecture. FIG. 14 is a diagram illustrating a software architecture for providing multiple screens according to an exemplary embodiment of the present invention.

[125] Referring to FIG. 14, a software architecture 1100 includes a device driver layer 1110, an API layer 1120, and an application layer 1130.

[126] The device driver layer 1110 receives service components from various multimedia content sources and decodes the received service components. Examples of the received service components include video information, audio information, and data information.

[127] The API layer 1120 generates a logical screen and a display screen and maps a service, the logical screen, and the display screen to one another.

[128] The application layer 1130 provides a user interface so that a user can dynamically configure a logical screen which displays a service or transmits a user command to the API layer 1120 so that the API layer 1120 can execute the user command.

[129] The user enables the device driver layer 1110 with the aid of the application layer 1130 to provide a display screen via a physical display device or to store the display screen in a storage medium. In addition, the user can enable the device driver layer 1110 to transmit a display screen to an external device via a network.

[130] For this, the device driver layer 1110 may include a plurality of output ports which can provide a display screen. Otherwise, API layer 1120 may include the plurality of output ports.

[131] In order to dynamically configure a plurality of logical screens on a display screen, the API layer 1120 may include a plurality of software modules, e.g., a multiscreen manager module 'MultiScreenManager' 1210, a multiscreen context module 'MultiScreenContext' 1230, a multiscreen context listener module 'MultiScreenContextListener' 1250, and a multiscreen context event module 'MultiScreenContextEvent' 1240, as illustrated in FIG. 15.

[132] The multiscreen manager module 1210 manages the multiscreen context module 1230, searches for a desired screen, displays information specifying what devices are shared by screens, registers the multiscreen context listener module 1250, or cancels the registration of the screen context listener module 1250.

[133] The multiscreen context module 1230 is an interface object associated with a

screen object 1220 and determines whether the screen object 1220 is to become a logical screen or a display screen according to an interface operation performed by the multiscreen context module 1230. Various attributes such as the attributes 510 through 570 illustrated in FIG. 6 may be set in the multiscreen context module 1230. The multiscreen context module 1230 can provide the functions 'SET', 'ADD', 'GET', and 'REMOVE' described above with reference to FIG. 6.

- [134] When attribute information of the screen object 1220 is altered by the multiscreen context module 1230, the multiscreen context event module 1240 serves as an event class announcing that the attribute information of the screen object 1220 has been changed, and the multiscreen context listener module 1250 serves as a listener interface object which can be realized in a predetermined application class which attempts to receive an event prompted by the multiscreen context event module 1240.
- [135] An application 1260 is a module which is driven on the application layer 1130. The application 1260 allows the user to choose a desired service and to freely arrange a plurality of logical screens on a display screen.
- [136] In detail, the application 1260 transmits various commands which allow the user to dynamically configure and manage logical screens to the multiscreen manager module 1210, and the multiscreen manager module 1210 controls operations corresponding to the various commands to be executed through the multiscreen context module 1230.
- [137] The multiscreen context module 1230 is associated with the screen object 1220 and manages the attribute information of the screen object 1220 illustrated in FIG. 6. In order to manage the attribute information of the screen object 1220, the multiscreen context module 1230 may include a variety of functions or methods. Further, these function may be performed by a separate module (not shown).
- [138] The multiscreen manager module 1210 receives service components provided by various service sources from the device driver layer 1110 and performs operations to display the received service components on a logical screen or a display screen. According to an exemplary embodiment of the present invention, the above functions can be performed another module (not illustrated).
- [139] FIG. 16 is a flowchart illustrating a method of displaying a plurality of services displayed on respective corresponding logical screens by the modules illustrated in FIG. 15 on a display screen according to an exemplary embodiment of the present invention.
- [140] Referring to FIG. 16, in operation S1310, the multiscreen manager module 1210 produces a display screen and a number of logical screens corresponding to the number of services to be performed.
- [141] In operation S1320, the multiscreen manager module 1210 connects the logical screens to respective corresponding services received from the device driver layer

1110. The multiscreen manager module 1210 may call a method 'addServiceContext' for each of the logical screens by setting service context objects of the received services as parameters for the logical screens services. The method 'addServiceContext' connects a logical screen to a service and may be provided by the multiscreen context module 1230.

[142] In operation S1330, once the logical screens are connected to the respective services, the multiscreen manager module 1210 connects the logical screens to the display screen. At this time, the multiscreen manager module 1210 may call a method 'setDisplayScreen' for each of the logical screens by setting a display screen object to which the logical screens are connected as a parameter. The method 'setDisplayScreen' connects a logical screen to a display screen and may be provided by the multiscreen context module 1230.

[143] A method 'setDisplayScreen' may be set to 'public void setDisplayScreen (HScreen screen) throws SecurityException, IllegalStateException', and this method allows an instance 'HScreen' that is provided as a parameter to be associated with the current logical screen. In this case, the instance 'HScreen' is preferably a display screen.

[144] A parameter of the method 'setDisplayScreen(HScreen screen)' may include a value of 'NULL'. In this case, when the method 'setDisplayScreen(HScreen screen)' is executed without exception handling, the current logical screen is no longer associated with the display screen.

[145] The execution of the methods 'SecurityException' and 'IllegalStateException' may be conducted as an exceptional operation for the method 'setDisplayScreen(HScreen screen)'.

[146] The method 'IllegalStateException' may be executed when a current screen is a logical screen or when a portion of a display screen associated with a current logical screen cannot change due to the characteristics of a host platform.

[147] In operation S1340, areas on the display screen to which the logical screens are to be respectively mapped are determined. At this time, a predetermined method provided by the multiscreen context module 1230 can be called to determine an area on the display screen where the logical screens are to be displayed.

[148] FIG. 17 is a flowchart illustrating a method of swapping services displayed on logical screens between the modules illustrated in FIG. 15 according to an exemplary embodiment of the present invention.

[149] In operation S1410, the multiscreen manager module 1210 interrupts a service to be swapped between two logical screens.

[150] Thereafter, in operation S1420, information regarding the service is swapped between the two logical screens. At this time, a method 'removeServiceContext' and a method 'addServiceContext' are called for each of the two logical screens, thereby

swapping service contexts set in the two logical screens between the two logical screens. The method 'removeContext' removes a service context connected to a logical screen, and the method 'addServiceContext' adds a new service context to a logical screen. The methods 'removeServiceContext' and 'addServiceContext' may be provided by the multiscreen context module 1230. According to the current exemplary embodiment of the present invention, service information regarding a service connected to logical services is swapped between the logical services, thereby obtaining the effect of swapping a main screen and a sub-screen. In addition, according to the current exemplary embodiment of the present invention, even when three or more services are performed on a display screen, they can be swapped between an arbitrary number of logical screens.

- [151] In operation S1430, occurrence of an event in which the connection between the service and the two logical screens has been changed is announced. Thereafter, in operation S1440, the multiscreen context event module 1240 transmits the event to the multiscreen context listener module 1250, and a service newly connected to the two logical screens begins to be performed.

#### **Industrial Applicability**

- [152] According to the present invention, it is possible to perform a plurality of services provided by various sources such as cable broadcasts, terrestrial broadcasts, various storage media, and external inputs, in various manners using a single physical display screen.
- [153] While the present invention has been particularly illustrated and described with reference to exemplary embodiments thereof, it will be understood by those of ordinary skill in the art that various changes in form and details may be made therein without departing from the spirit and scope of the present invention as defined by the following claims. Therefore, it is to be understood that the above-described exemplary embodiments have been provided only in a descriptive sense and will not be construed as placing any limitation on the scope of the invention.

## Claims

- [1] An apparatus for providing multiple screens, the apparatus comprising:  
a service processing module which generates a plurality of logical screens displaying a plurality services and a display screen and performs service swapping between the logical screens; and  
an output module which maps the logical screens to arbitrary locations on the display screen.
- [2] The apparatus of claim 1, further comprising:  
an interface module which receives a service swapping request from a user or an application,  
wherein the service processing module swaps the services between the screens generated by the service processing module in response to the service swapping request.
- [3] The apparatus of claim 1, wherein the logical screen that is an object of service swapping comprises a main screen and a picture-in-picture screen.
- [4] The apparatus of claim 3, wherein if a service displayed on the main screen comprises an application and the application cannot be executed on the picture-in-picture screen, the service processing modules interrupts the application.
- [5] The application of claim 4, wherein the service processing module interrupts the application by temporally suspending the application or completely terminating the application.
- [6] The apparatus of claim 4, wherein if the service swapping is re-accomplished between the main screen and the picture-in-picture screen to connect the service including the application to the main screen, the service processing module re-executes the application.
- [7] The apparatus of claim 1, wherein the service comprises at least one of video information, audio information, and data information.
- [8] The apparatus of claim 7, wherein the video information, the audio information, or the data information is provided by a broadcast signal, a storage medium, or a network.
- [9] The apparatus of claim 7, wherein the data information comprises information indicating whether the application in the service can be executed on a picture-in-picture screen.
- [10] The apparatus of claim 1, further comprising at least one of a physical display device which outputs the display screen, a storage medium which stores the display screen, and an external output module which transfers the display screen to an external device.

- [11] A method of dynamically configuring multiple screens, the method comprising: generating a plurality of logical screens displaying services and a display screen; mapping the logical screens to arbitrary locations on the display screen; and swapping the services between the logical screens.
- [12] The method of claim 11, further comprising: receiving a service swapping request from a user or an application; wherein the swapping of the services is performed in response to the receiving of the service swapping request.
- [13] The method of claim 11, wherein the logical screen that is an object of service swapping comprises a main screen and a picture-in-picture screen.
- [14] The method of claim 13, wherein the swapping of the services comprises interrupting the application if a service displayed on the main screen includes an application and the application cannot be executed on the picture-in-picture screen.
- [15] The method of claim 14, wherein the interrupting of the application comprises suspending the application.
- [16] The method of claim 14, wherein the interrupting of the application comprises terminating the application.
- [17] The method of claim 14, further comprising: re-executing the application, if the service swapping is re-accomplished between the main screen and the picture-in-picture screen to connect the service including the application to the main screen.
- [18] The method of claim 11, wherein the service comprises at least one of video information, audio information, and data information.
- [19] The method of claim 18, wherein the video information, the audio information, or the data information is provided by a broadcast signal, a storage medium, or a network.
- [20] The method of claim 18, wherein the data information comprises information indicating whether the application in the service can be executed on a picture-in-picture screen.
- [21] The method of claim 11, further comprising: providing at least one of a physical display device outputting the display screen, a storage medium storing the display screen, and an external output module transferring the display screen to an external device.

**FIG. 1A**

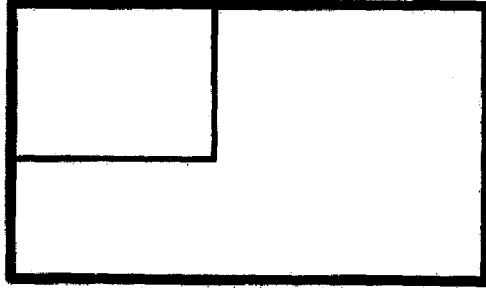

**FIG. 1B**

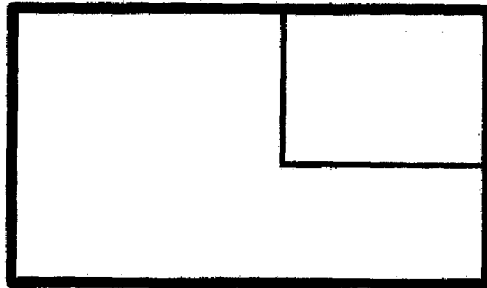

**FIG. 1C**

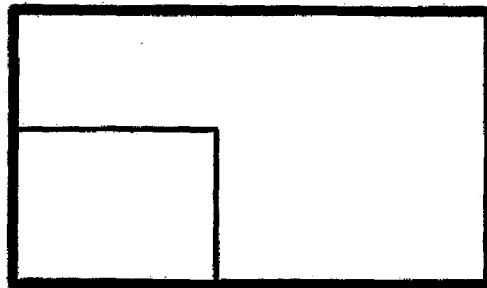

**FIG. 1D**

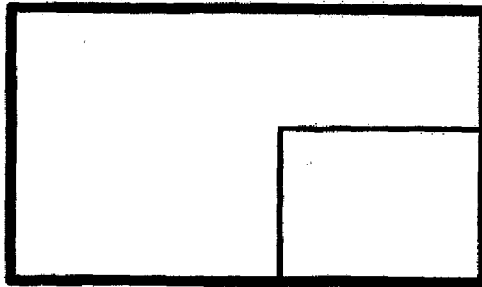

**FIG. 1E**

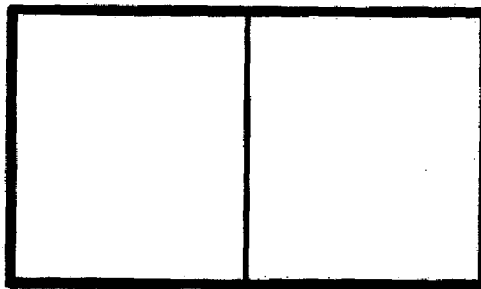

**FIG. 1F**

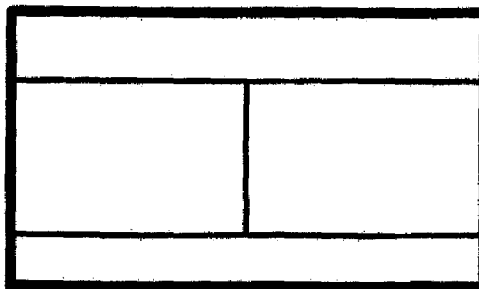

**FIG. 1G**

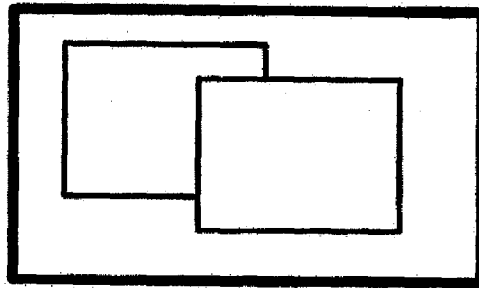

**FIG. 1H**

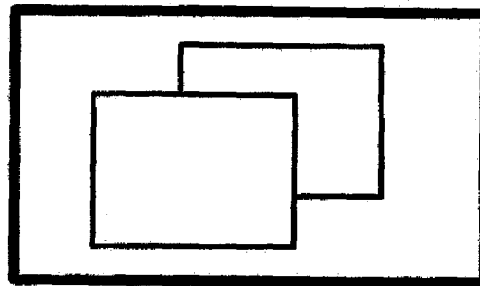

FIG. 2

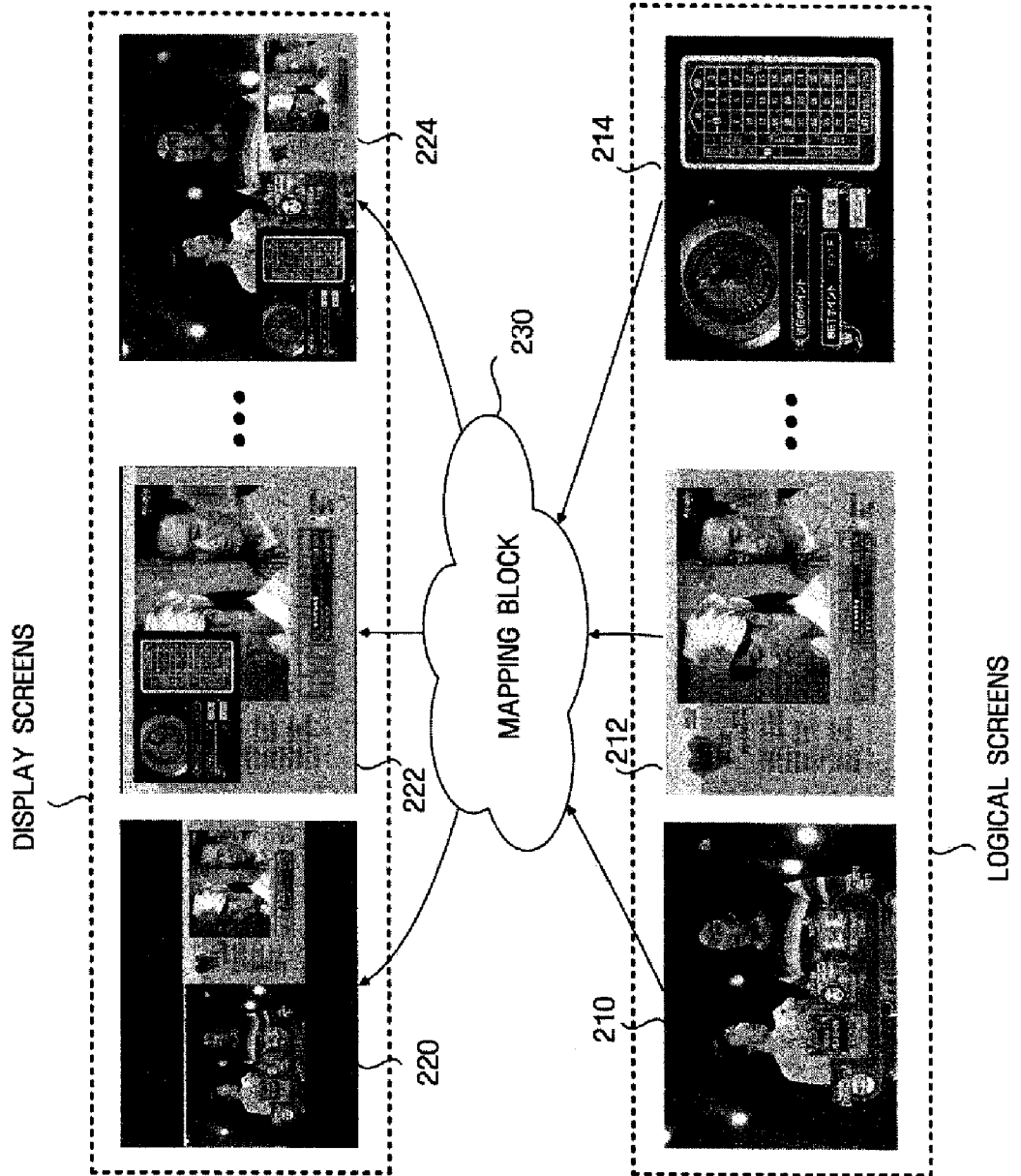

FIG. 3A

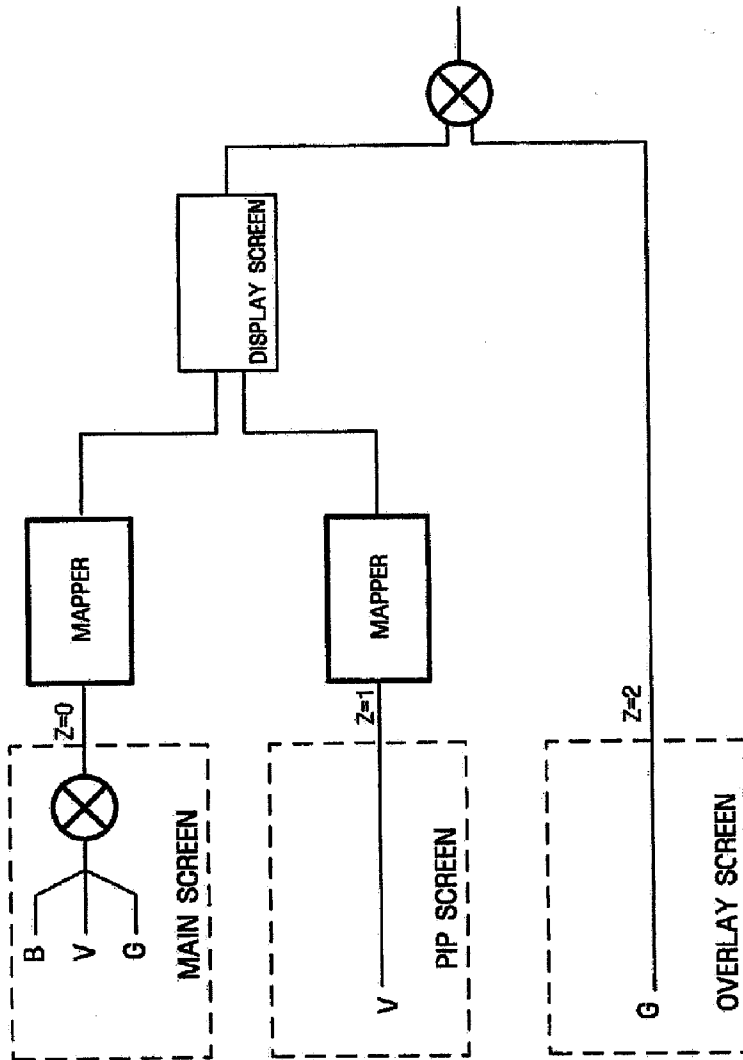

FIG. 3B

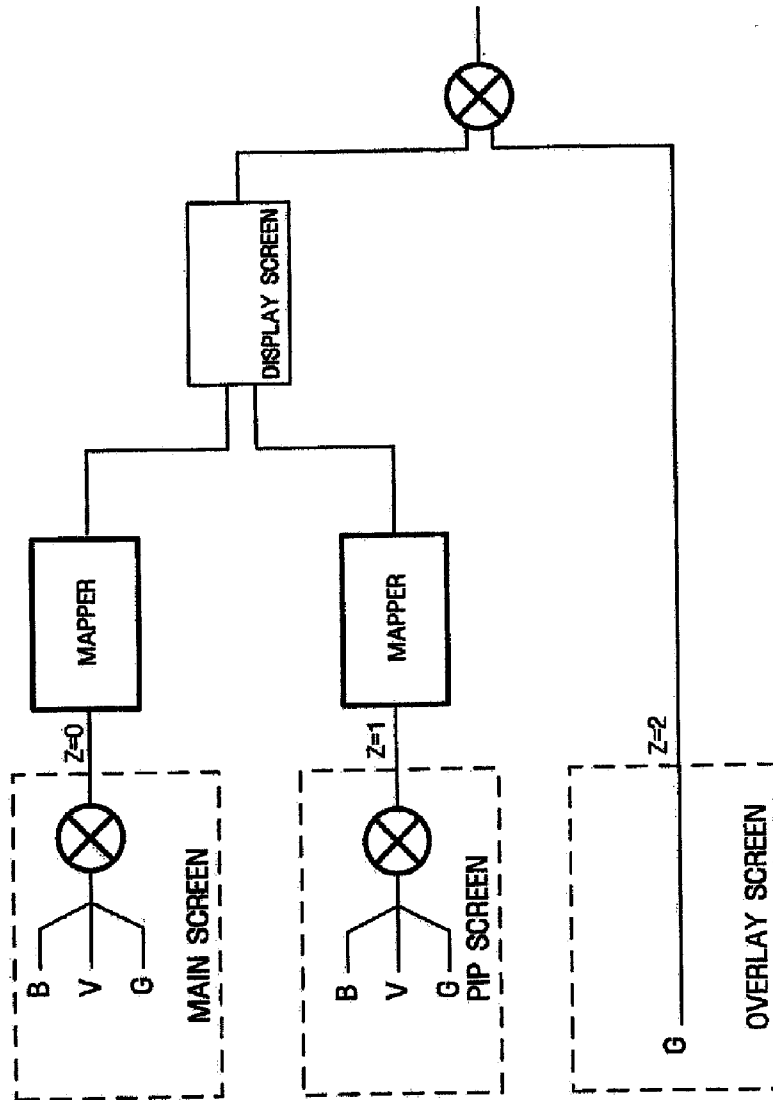

FIG. 3C

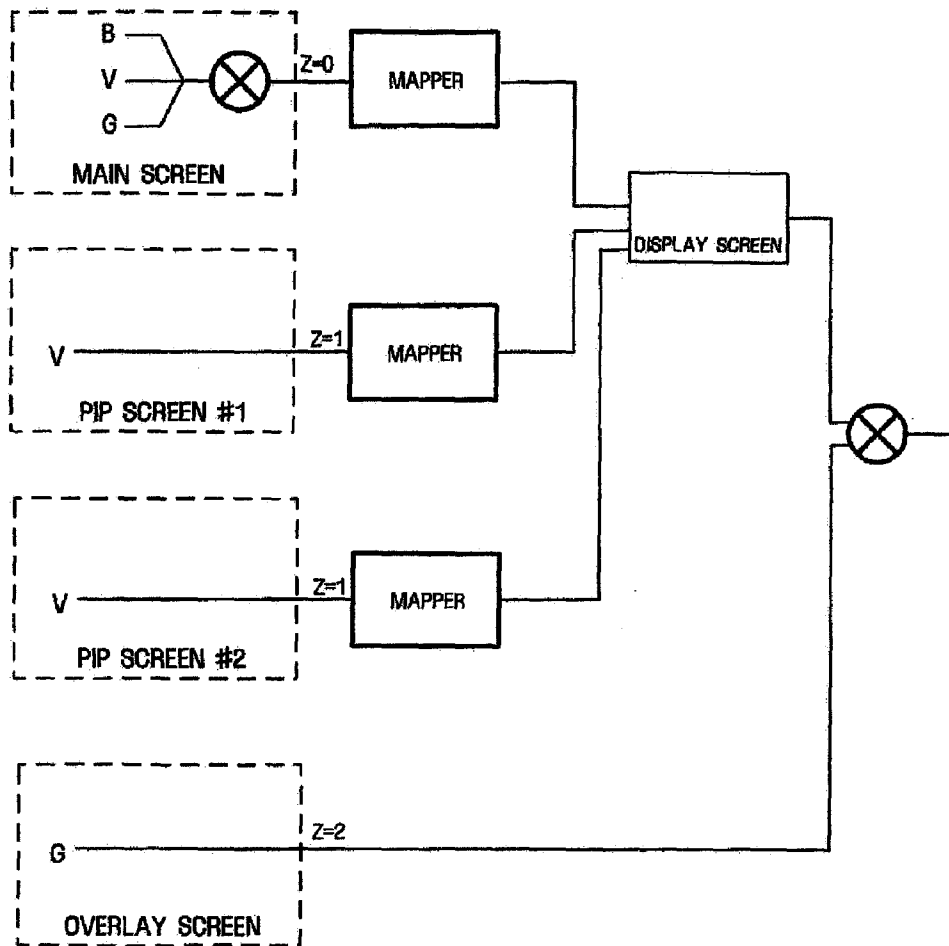

FIG. 3D

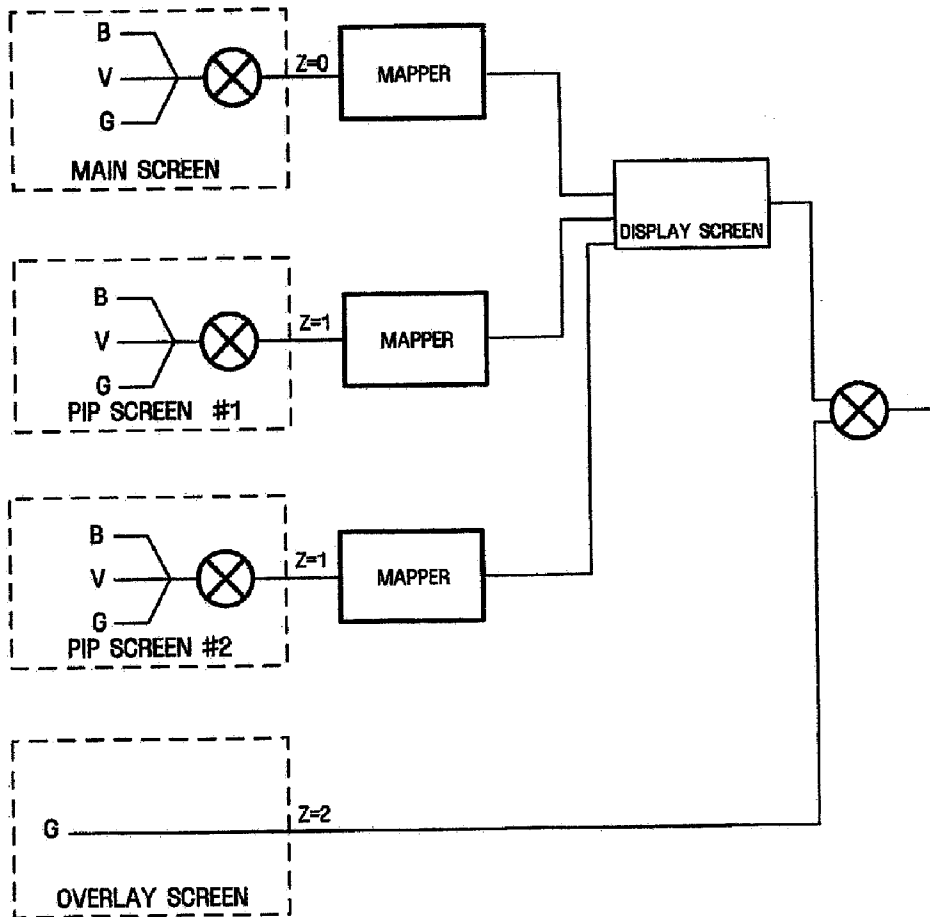
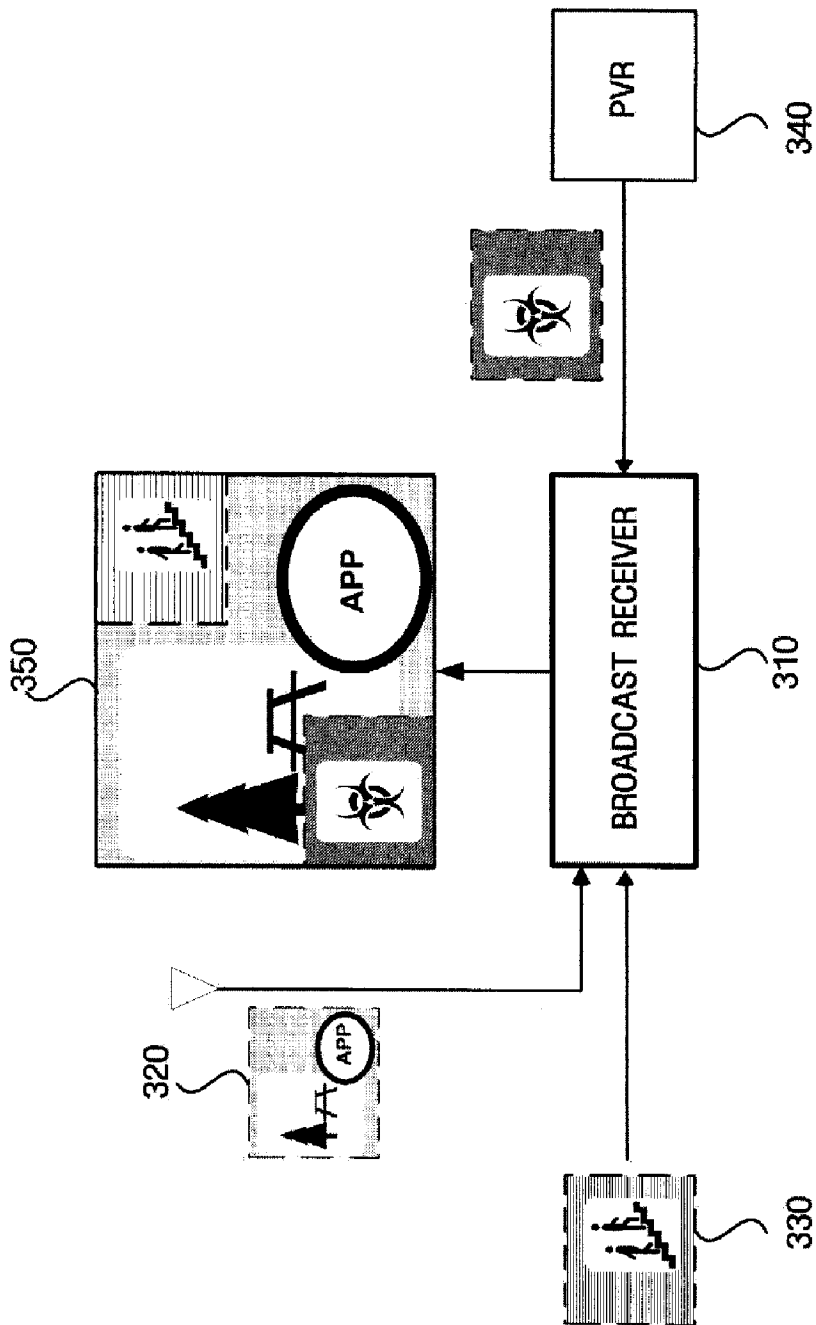

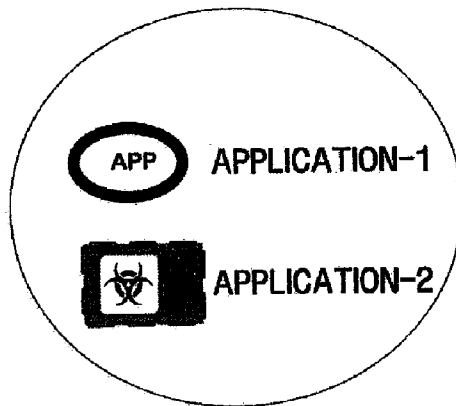

FIG. 4



**FIG. 5A**

**ABSTRACT SERVICE**



**FIG. 5B**

**NON-ABSTRACT SERVICE**

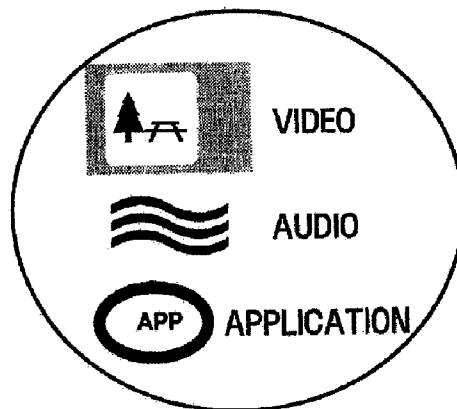

FIG. 6

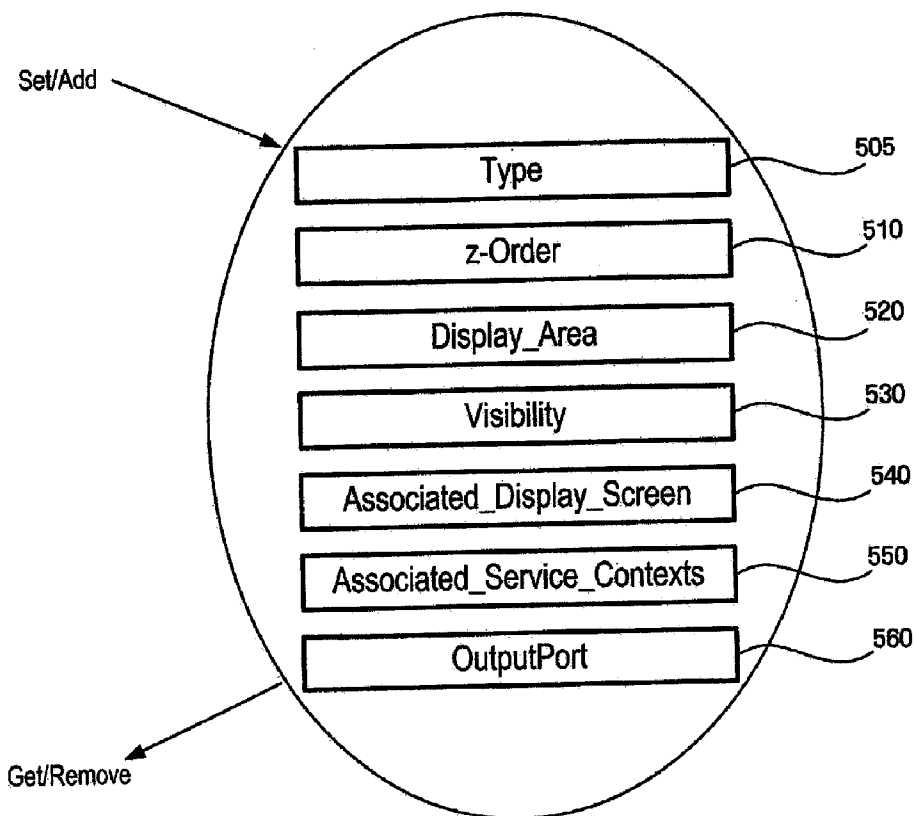

FIG. 7

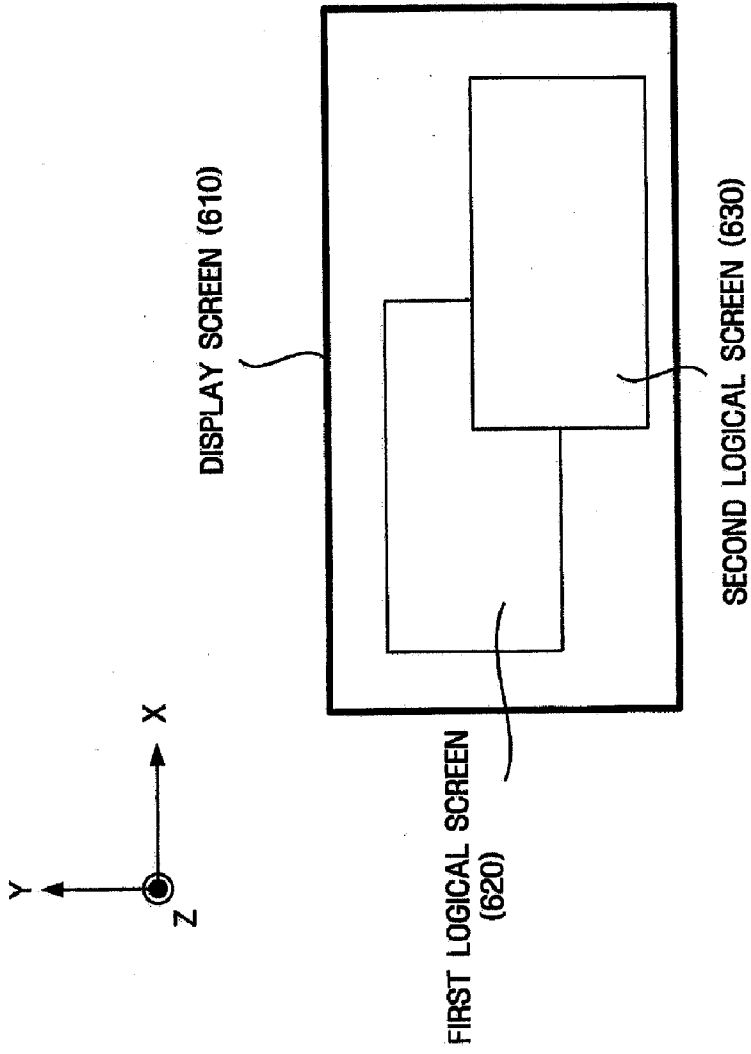

FIG. 8A

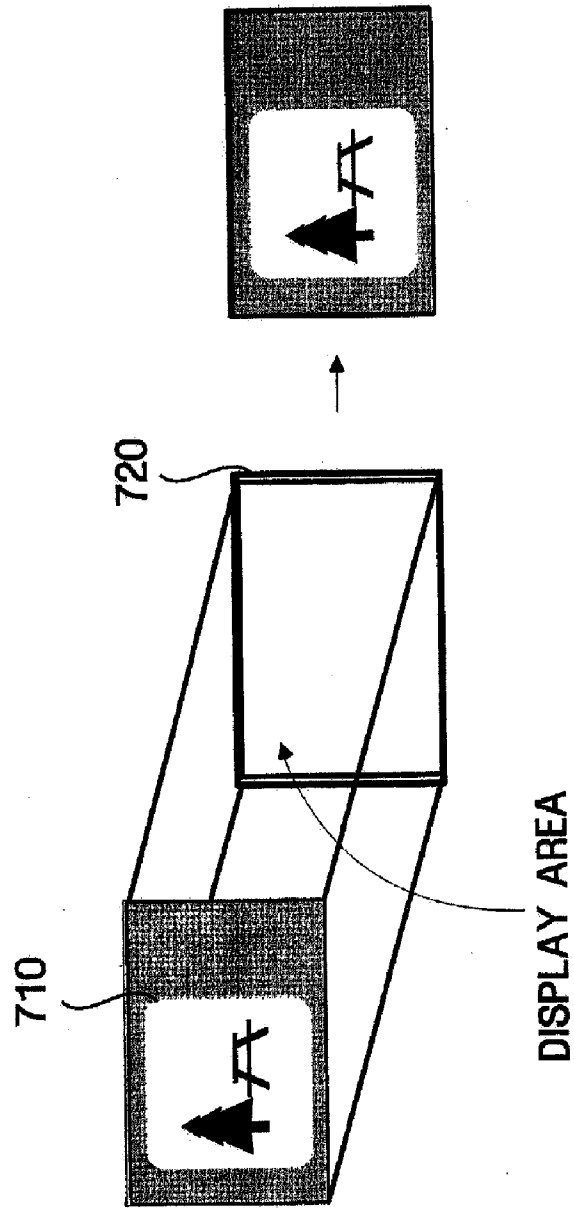

FIG. 8B

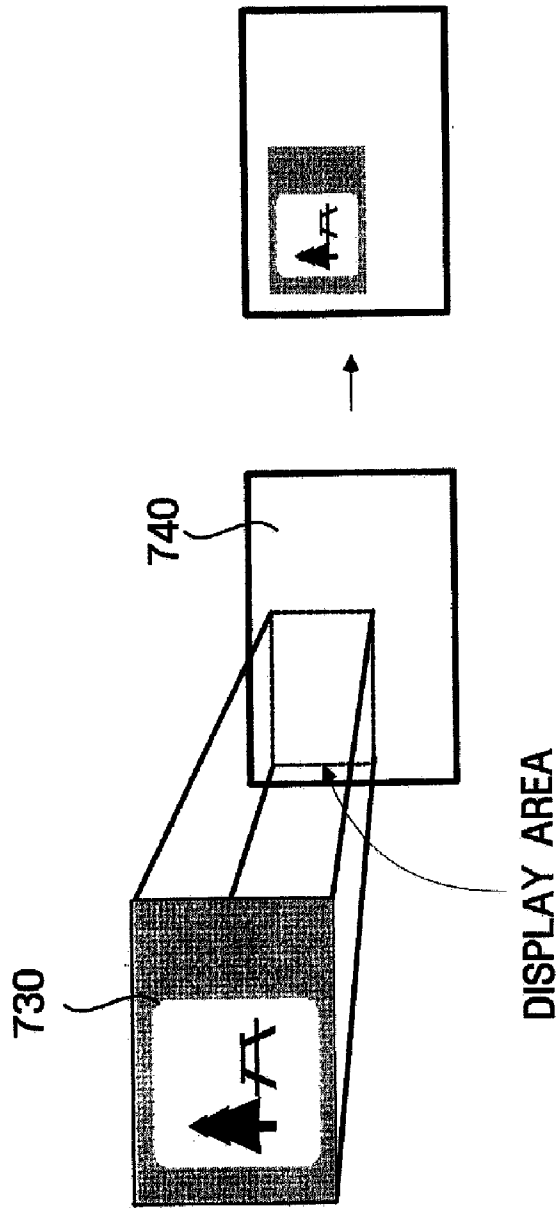

FIG. 9

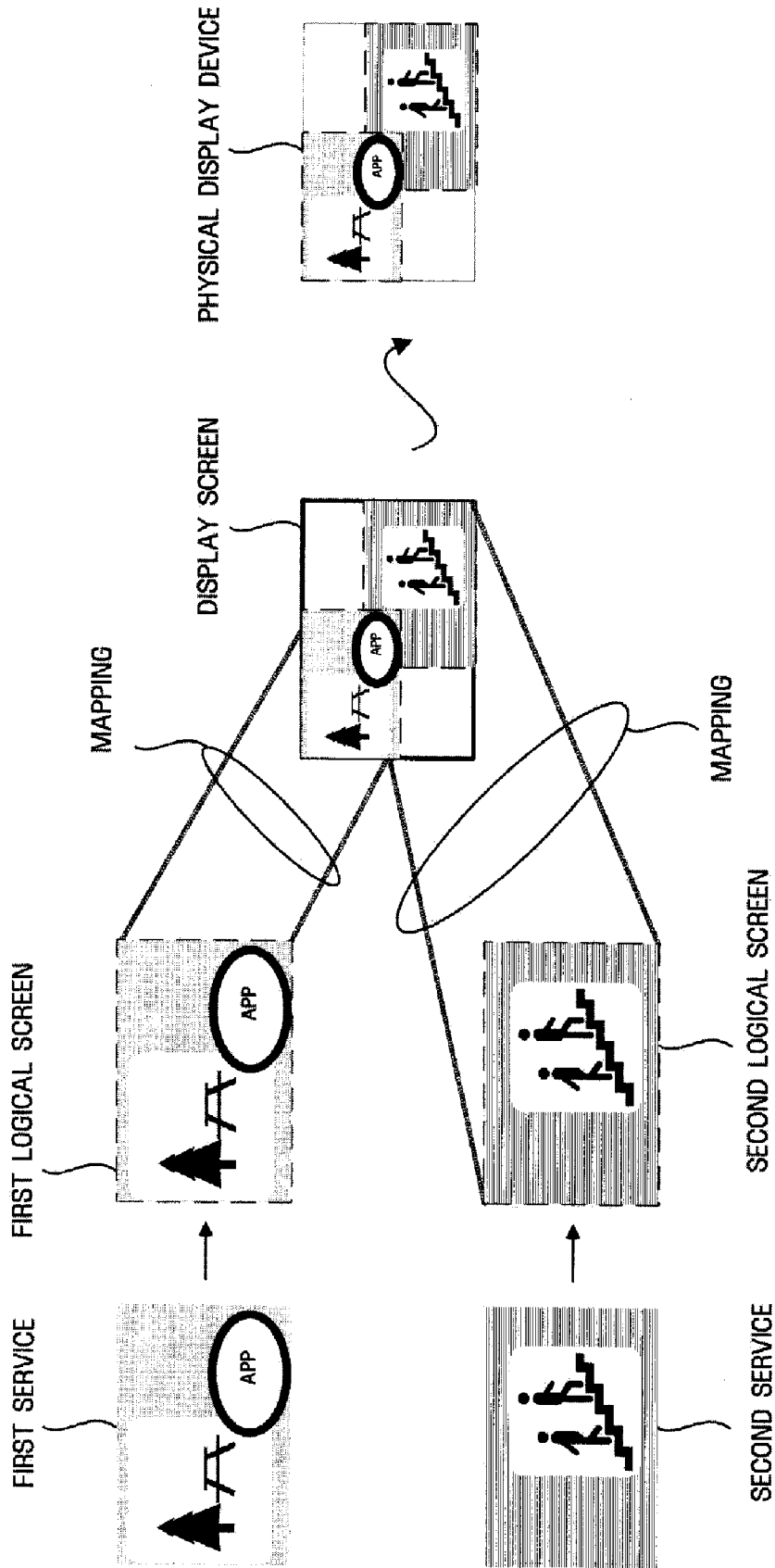

FIG. 10

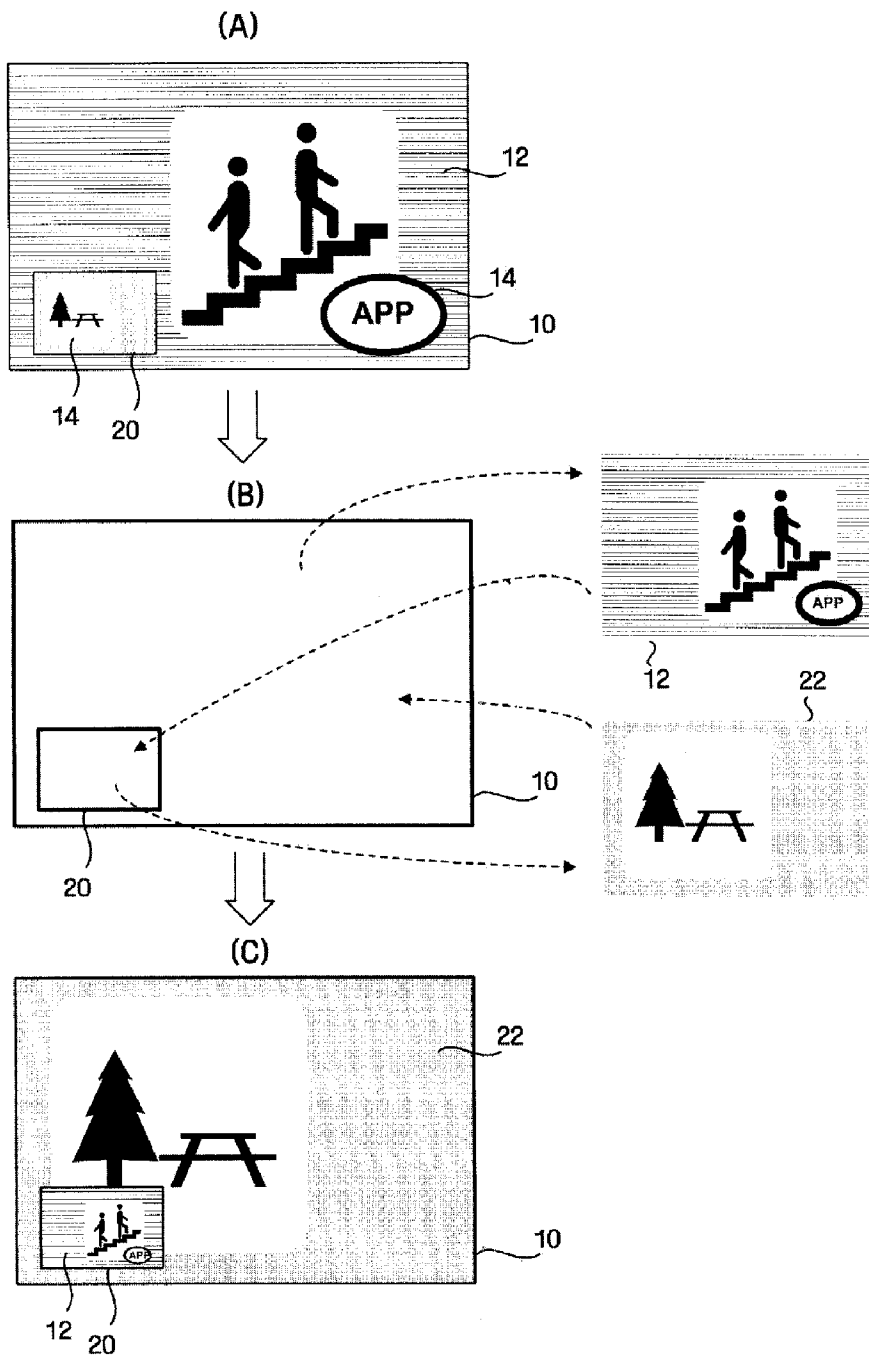

FIG. 11

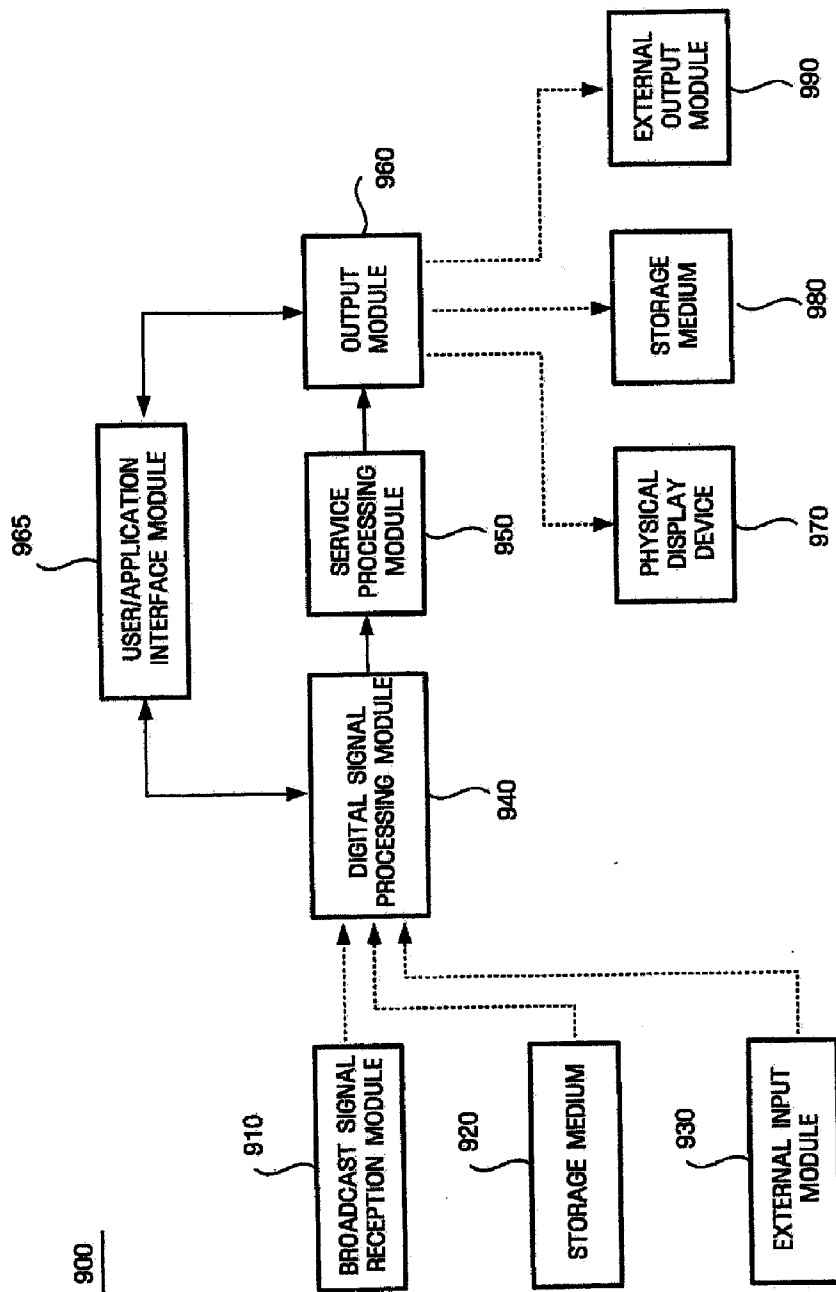

FIG. 12

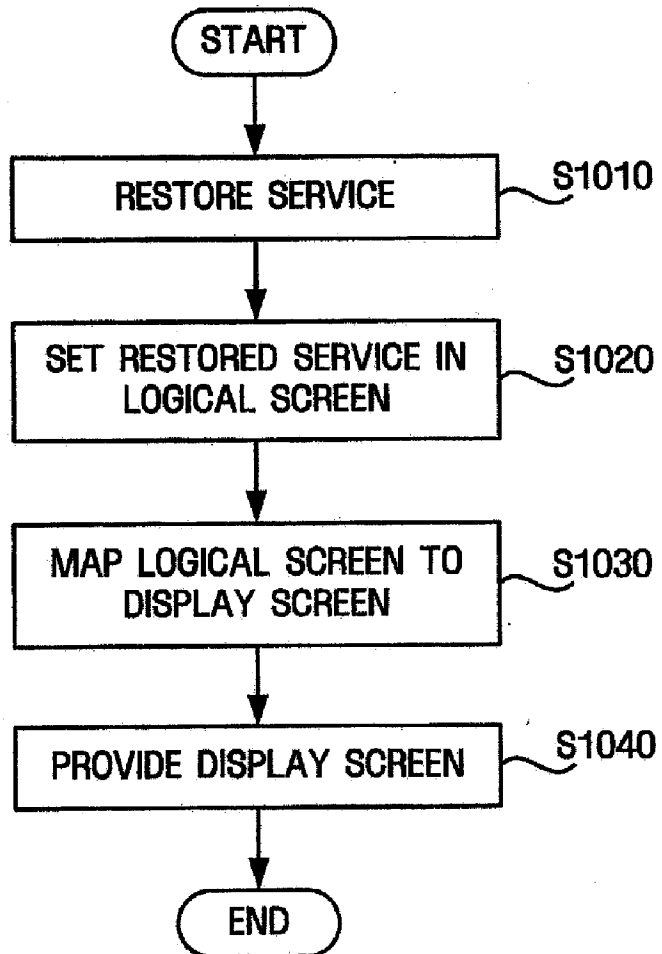

FIG. 13

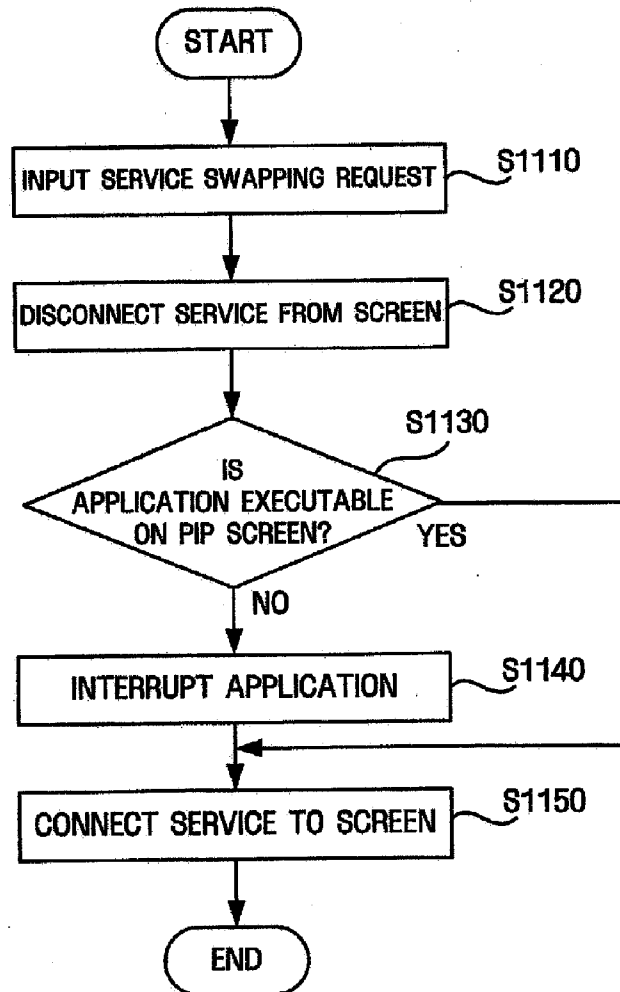
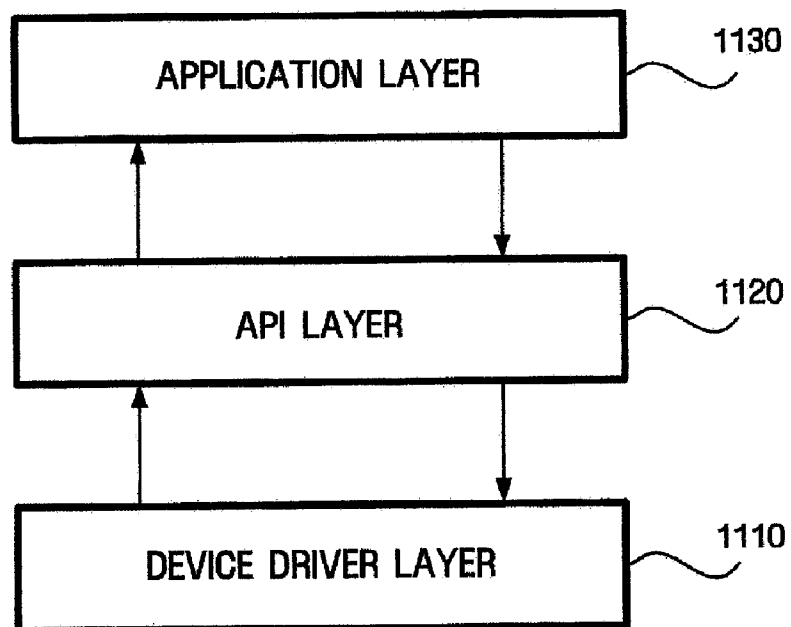

FIG. 14

1100

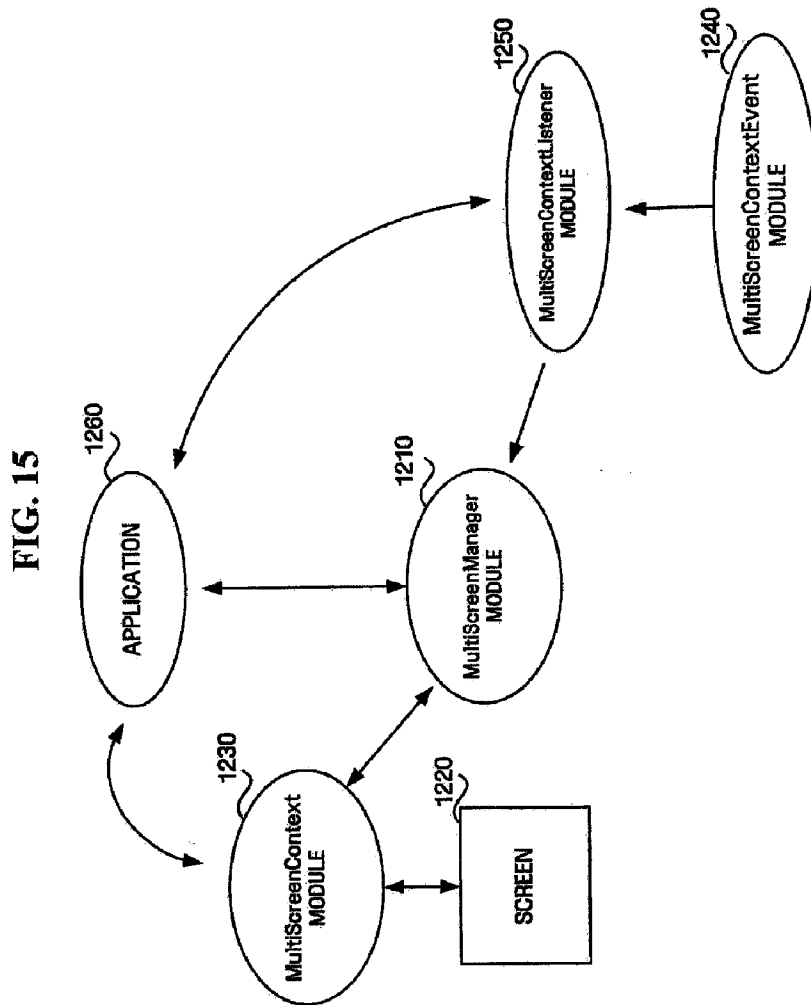

FIG. 16

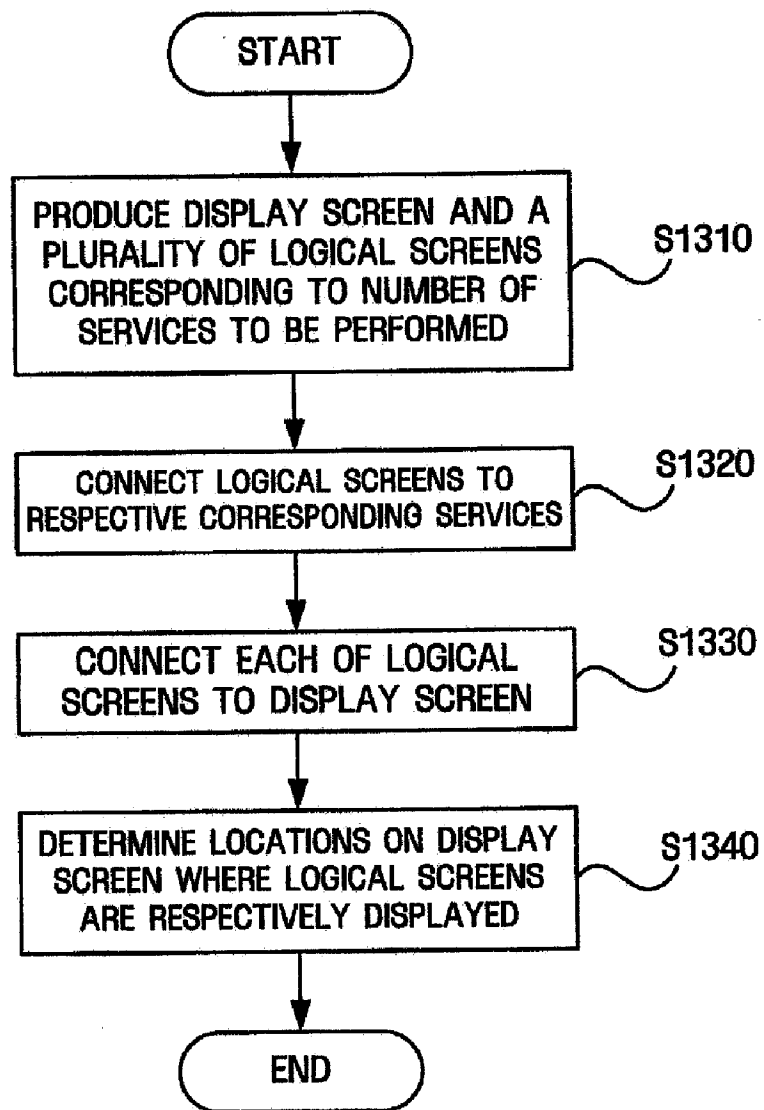
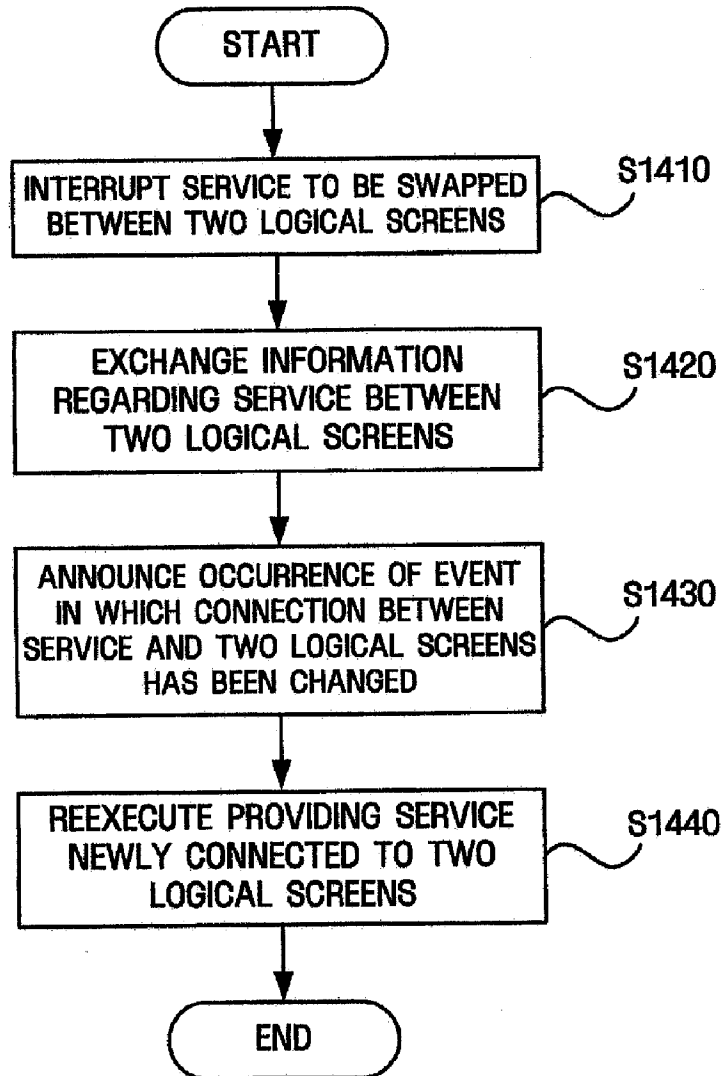

FIG. 17



## INTERNATIONAL SEARCH REPORT

International application No.  
PCT/KR2006/003081**A. CLASSIFICATION OF SUBJECT MATTER****H04N 5/44(2006.01)i**

According to International Patent Classification (IPC) or to both national classification and IPC

**B. FIELDS SEARCHED**

Minimum documentation searched (classification system followed by classification symbols)

H04N

Documentation searched other than minimum documentation to the extent that such documents are included in the fields searched

Korean Patents and applications for inventions since 1975.

Korean Utility models and applications for Utility models since 1975

Japanese Utility models and applications for Utility models since 1975

Electronic data base consulted during the international search (name of data base and, where practicable, search terms used)

PAJ, USPTO, KIPRIS, TIMEPASS : "multi screen, service swapping, dynamic configuration"

**C. DOCUMENTS CONSIDERED TO BE RELEVANT**

Category*	Citation of document, with indication, where appropriate, of the relevant passages	Relevant to claim No.
A	WO 2001-04868 A ( SUN MICRO SYSTEMS, INC) 18 JAN 2001 Abstract, Fig. 3	1-21
A	US 5847771 A ( Leo Cloutier et al.) 08 DEC 1998 Abstract, Fig. 3	1-21
A	US 2002-0049975 A (William L. Thomas et al.) 25 APR 2002 Abstract, Fig. 1	1-21
A	WO 2004-047433 A (PHILIPS ELECTRONICS N.V.) 03 JUN 2004 Abstract, Fig. 1	1-21
A	WO 2003-077540 A (PHILIPS ELECTRONICS N.V.) 18 SEP 2003 Abstract, Fig. 2	1-21

 Further documents are listed in the continuation of Box C. See patent family annex.

\* Special categories of cited documents:

"A" document defining the general state of the art which is not considered to be of particular relevance

"E" earlier application or patent but published on or after the international filing date

"L" document which may throw doubts on priority claim(s) or which is cited to establish the publication date of citation or other special reason (as specified)

"O" document referring to an oral disclosure, use, exhibition or other means

"P" document published prior to the international filing date but later than the priority date claimed

"T" later document published after the international filing date or priority date and not in conflict with the application but cited to understand the principle or theory underlying the invention

"X" document of particular relevance; the claimed invention cannot be considered novel or cannot be considered to involve an inventive step when the document is taken alone

"Y" document of particular relevance; the claimed invention cannot be considered to involve an inventive step when the document is combined with one or more other such documents, such combination being obvious to a person skilled in the art

"&amp;" document member of the same patent family

Date of the actual completion of the international search

14 NOVEMBER 2006 (14.11.2006)

Date of mailing of the international search report

**14 NOVEMBER 2006 (14.11.2006)**

Name and mailing address of the ISA/KR

Korean Intellectual Property Office  
920 Dunsan-dong, Seo-gu, Daejeon 302-701,  
Republic of Korea

Facsimile No. 82-42-472-7140

Authorized officer

LEE, Jin Ick

Telephone No. 82-42-481-5770



**INTERNATIONAL SEARCH REPORT**

Information on patent family members

International application No.

PCT/KR2006/003081

Patent document cited in search report	Publication date	Patent family member(s)	Publication date		
W00104868A1	18.01.2001	W0200104743A2	18.01.2001		
		W0200104744A2	18.01.2001		
		W0200104868A1	18.01.2001		
		W0200105158A1	18.01.2001		
		AT289091E	15.02.2005		
		AU200059345A1	30.01.2001		
		AU200060973A1	30.01.2001		
		AU200060973B2	30.01.2001		
		AU200060992A1	30.01.2001		
		AU200063495A1	30.01.2001		
		AU200063495B2	30.01.2001		
		AU776813B2	23.09.2004		
		AU781357B2	19.05.2005		
		CA2373036A1	18.01.2001		
		CA2378588A1	18.01.2001		
		CA2378844A1	18.01.2001		
		CN1156753C	07.07.2004		
		CN1227588C	16.11.2005		
		CN1264354C	12.07.2006		
		CN1360694A	24.07.2002		
		CN1360695A	24.07.2002		
		CN1373967A	09.10.2002		
		EP01192617A1	03.04.2002		
		EP01194838A2	10.04.2002		
		EP01194840A2	10.04.2002		
		EP01197090A2	17.04.2002		
		JP2003504753T2	04.02.2003		
		JP2003504754T2	04.02.2003		
		JP2003504923T2	04.02.2003		
		JP2003522442T2	22.07.2003		
		KR1020020030784	25.04.2002		
		KR1020020022085	23.03.2002		
		KR1020020023414	28.03.2002		
		KR1020020035558	11.05.2002		
		US6701334B1	02.03.2004		
		US6762798B1	13.07.2004		
		US6874145B1	29.03.2005		
		US6986155BA	10.01.2006		
		US05847771	08.12.1998	US5847771A	08.12.1998

**INTERNATIONAL SEARCH REPORT**

Information on patent family members

International application No.

PCT/KR2006/003081

Patent document cited in search report	Publication date	Patent family member(s)	Publication date
US20020049975A1	25.04.2002	AU2001251346A8	23.10.2001
		AU200151346A1	23.10.2001
		AU200151346A5	23.10.2001
		US2002049975A1	25.04.2002
		US2002049975AA	25.04.2002
		W00177953A2	18.10.2001
		W0200177953A2	18.10.2001
		W0200177953A3	14.08.2003
W02004047433A1	03.06.2004	AU2003272026A1	15.06.2004
		AU2003272026AA	15.06.2004
		CN1711759A	21.12.2005
		EP01566055A1	24.08.2005
		EP1566055A1	24.08.2005
		JP18506876	23.02.2006
		JP2006506876T2	23.02.2006
		KR1020050086696	30.08.2005
		US20060010476A1	12.01.2006
		W003077540A1	18.09.2003
AU2003252809AA	22.09.2003		
CN1643902A	20.07.2005		
EP01486059A1	15.12.2004		
EP1486059A1	15.12.2004		
JP17520407	07.07.2005		
JP2005520407T2	07.07.2005		
KR1020040093126	04.11.2004		
US20050120379A1	02.06.2005		
US2005120379A1	02.06.2005		
US2005120379AA	02.06.2005		