



Europäisches Patentamt  
European Patent Office  
Office européen des brevets



(11) **EP 0 851 151 A1**

(12) **EUROPEAN PATENT APPLICATION**

(43) Date of publication:  
**01.07.1998 Bulletin 1998/27**

(51) Int Cl. 6: **F16H 55/36**

(21) Application number: **97310601.6**

(22) Date of filing: **24.12.1997**

(84) Designated Contracting States:  
**AT BE CH DE DK ES FI FR GB GR IE IT LI LU MC  
NL PT SE**  
Designated Extension States:  
**AL LT LV MK RO SI**

(72) Inventor: **Ohya, Masakiyo  
Kosyi-shi, Shizuoka-ken (JP)**

(74) Representative: **Milhench, Howard Leslie et al  
R.G.C. Jenkins & Co.  
26 Caxton Street  
London SW1H 0RJ (GB)**

(30) Priority: **26.12.1996 JP 347943/96**

(71) Applicant: **FUJIKIKO KABUSHIKI KAISHA  
Tokyo (JP)**

(54) **Pulley and manufacturing method of the same**

(57) A web section (12) extends from a central portion in an axial direction of an inner cylindrical section (11), an outer cylindrical section (13) is formed at an outer circumferential portion of the web section (12), coax-

ially with respect to the inner cylindrical section (11) about the web section (12), and V-shaped grooves (14) are formed on an outer circumference of the outer cylindrical section (13), integrally by a cold working.

**FIG.2**

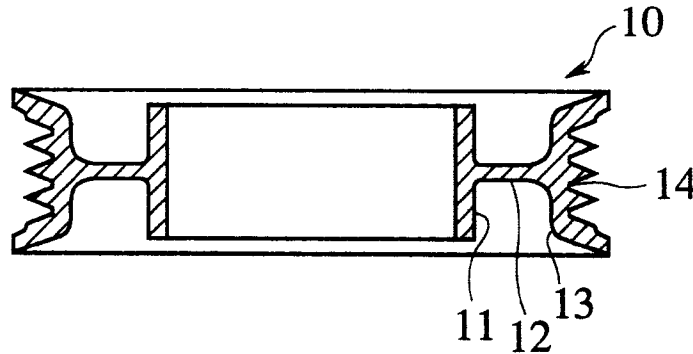

**EP 0 851 151 A1**

## Description

### BACKGROUND OF THE INVENTION

#### 1. Field of the Invention

This invention relates to a pulley having V-shaped grooves on its outer circumference and relates to a manufacturing method of the same.

#### 2. Description of Relevant Art

As shown in FIG. 1, a pulley which was obtained by working a thin iron plate, for example, is known. Namely, this pulley is arranged so that a cylindrical bearing section (inner cylindrical section) 1, a web section 2 and a rim section (outer cylindrical section) 3 are formed by bending an iron plate provided as a material by press, etc., and that a plurality of V-shaped grooves 4 are formed on the outer circumference of the rim section 3.

Since the web section 2 is formed by bending the iron plate, one end portions of the bearing section 1 and rim section 3 in the axial direction are cantilevered. Moreover, the V-shaped grooves 4 are formed on the outer circumference of the rim section 3 by compressing the rim section 3 in the axial direction and enlarging its thickness. Here, the bearing section 1 is arranged so that its inner circumferential surface is engaged with a bearing 5.

In the conventional pulley, tension of a belt in the V-shaped grooves 4 is applied to the rim section 3. However, since one end of the rim section 3 in the axial direction is cantilevered by the web section 2, when the tension is applied thereto from the belt, strong bending moment is applied to the rim section 3, web section 2 and bearing section 1. For this reason, there arose problems such that since the whole portion was easily deflected, vibration and noise occurred easily, and durability is deteriorated. Moreover, since the pulley is formed by using a thin plate, when the V-shaped grooves 4 are formed, the thickness of the rim section 3 should be increased. For this reason, there arose a problem such that manufacturing cost was increased due to the process of increasing the thickness.

### SUMMARY OF THE INVENTION

The present invention has been achieved with such points in view.

It therefore is an object of the present invention to provide a pulley which is capable of reducing vibration and noise, improving durability and reducing the manufacturing cost and to provide a manufacturing method thereof.

To achieve the object, a first aspect of the invention provides a pulley comprising; an inner cylindrical section, a web section which is extended from a central portion in an axial direction of the inner cylindrical section,

an outer cylindrical section which is formed at an outer circumferential portion of the web section coaxially with respect to the inner cylindrical section about the web section, and V-shaped grooves which are formed on an outer circumference of the outer cylindrical section are formed integrally by cold working.

According to a second aspect of the invention, the web section is formed so that its thickness becomes thicker gradually with directing towards the inner cylindrical section and outer cylindrical section.

According to a third aspect of the invention, the inner cylindrical section is formed with a bearing stopper.

Further, to achieve the object described, a fourth aspect of the invention provides a manufacturing method of a pulley, comprising the steps of: forming a web section on a middle portion in a radial direction of a thick ring body by crushing the middle portion by cold working, forming an inner cylindrical section at an inner circumferential portion of the web section, a central portion of the inner cylindrical section being the web section, forming a redundant section at the outer circumferential portion of the web section, a central portion of the redundant section being the web section, and forming an outer cylindrical section having V-shaped grooves on its outer circumferential portion, the outer cylindrical section being formed at the outer circumferential portion of the web section coaxially with respect to the inner cylindrical section about the web section by cold-working V-shaped grooves on an outer circumference of the redundant section.

According to a fifth aspect of the invention, the thick ring body is formed such that a thick circulate plate body is formed by crushing a cylindrical material by cold working, that a circular thin section is formed by crushing a central portion of the thick circular plate body in a circular shape by cold working, and that the circular thin section is blanked by press.

According to a sixth aspect of the invention, the thick ring body is formed by blanking a plate shaped material by press.

According to a seventh aspect of the invention, the web section is formed by crushing a central portion in a radial direction of the thick ring body by cold working so that its thickness becomes thicker gradually with directing towards the inner cylindrical section and outer cylindrical section.

In the invention according to the first aspect arranged in the above manner, since the web section connects the central portion of the inner cylindrical section with the central portion of the outer cylindrical portion, even if tension of the belt is applied to the V-shaped grooves, bending moment generated by the tension is small. Further, since the tension is applied to the outer cylindrical section symmetrically with respect to the web section, the bending moment can be prevented from being applied to the web section and inner cylindrical section. Therefore, the whole portion is extremely difficult to deflect, so vibration and noise due to the deflection

can be reduced, and the durability can be improved.

According to the second aspect, since the web section is formed so that its thickness becomes thicker gradually with directing towards the inner cylindrical section and outer cylindrical section, rigidity of a connecting portion between the web section and inner cylindrical section and a connecting portion between the web section and outer cylindrical section can be improved, and strength and durability can be improved.

According to the third aspect, the pulley has an integral bearing stopper.

According to the fourth aspect, since a layered structure is obtained by cold working and the strength is increased by hardening due to the cold working, the durability can be improved. Moreover, since the thickness of the whole portion can be thin, light-weighting and miniaturization can be realized. Further, since the surface accuracy is improved by the cold working, the finishing step, for example, can be omitted, and the cost can be reduced.

Furthermore, in the cold working step, since the outer cylindrical section can be formed so as to have an enough thickness to form V-shaped grooves as a redundant section, the step of increasing a thickness which is shown in the conventional example is not required. Therefore, the manufacturing steps can be simplified, and the productivity can be improved and the cost can be reduced.

According to the fifth aspect, since the thick ring body is formed by cold-working a cylindrical material, yield is improved by cold forging, and material costs can be reduced, thereby making it possible to reduce the cost.

According to the sixth aspect, since the thick ring body is formed by blanking a plate-shaped material by press, the productivity can be improved, and the cost can be reduced.

According to the seventh aspect, when the web section is cold-worked, a material positioned in the web section is easy to flow to the inner cylindrical section and outer cylindrical section. Therefore, a force and time required for the cold working can be reduced.

### BRIEF DESCRIPTION OF THE DRAWINGS

The above and further objects and novel features of the present invention will more fully appear from the following detailed description when the same is read in conjunction with the accompanying drawings, in which:

- FIG. 1 is a sectional view showing a pulley as a conventional example;  
 FIG. 2 is a sectional view showing a pulley according to the first embodiment of the present invention;  
 FIG. 3 is a drawing showing a manufacturing method of the pulley, i.e., a side view showing a cylindrical material;  
 FIG. 4 is a drawing showing the manufacturing

method of the pulley, i.e., a side view showing a thick circular plate;

FIG. 5 is a drawing showing the manufacturing method of the pulley, i.e., a sectional view showing a state that a thick circular portion is formed on the thick circular plate;

FIG. 6 is a drawing showing the manufacturing method of the pulley, i.e., a sectional view showing a thick ring body;

FIG. 7 is a drawing showing the manufacturing method of the pulley, i.e., a sectional view showing a rough shaped section of the pulley;

FIG. 8 is a drawing showing a forming unit of the pulley, i.e., a sectional view showing a unit for forming the rough shaped section of the pulley;

FIG. 9 is a drawing showing a forming unit of the pulley, i.e., a sectional view showing a unit for forming a rim section and V-shaped grooves;

FIG. 10 is a sectional view of the pulley according to the second embodiment of the present invention;

FIG. 11 is a drawing showing a forming unit of the pulley, i.e., a sectional view showing a unit for forming the rough shaped section of the pulley;

FIG. 12 is a drawing showing a forming unit of the pulley, i.e., a sectional view showing a unit for forming the rim section and V-shaped grooves;

FIG. 13 is a sectional view showing the rough shape section of the pulley according to the third embodiment of the present invention;

FIG. 14 is a sectional view showing the finished pulley;

FIG. 15 is a drawing showing a forming unit of the pulley, i.e., a sectional view showing a unit for forming the rough shaped section of the pulley;

FIG. 16 is a drawing showing a forming unit of the pulley, i.e., a sectional view showing a unit for forming the rim section and V-shaped grooves;

FIG. 17 is a perspective view showing a plate-shaped material used in the fourth embodiment of the present invention; and

FIG. 18 is a drawing showing the manufacturing method of the pulley, i.e., a perspective view showing a thick ring body.

### DETAILED DESCRIPTION OF THE PREFERRED EMBODIMENTS

There will be detailed below the preferred embodiments of the present invention with reference to FIGS. 2 through 16. Here, FIGs. 2 through 9 show the first embodiment, FIGs. 10 through 12 show the second embodiment, FIGs. 13 through 16 show the third embodiment, and FIGs. 17 and 18 show the fourth embodiment.

First, the description will be given as to the first embodiment of the present invention on reference to FIGs. 2 through 9. Namely, a pulley 10 in the first embodiment, as shown in FIG. 2, is obtained by forming a bearing section (inner cylindrical section) 11 formed in a cylin-

dricial shape, a web section 12 which is extended from a central portion of the bearing section 11 in the axial direction to the outside radially, a cylindrical rim section (outer cylindrical section) 13 which is formed at the outer circumferential portion of the web section 12 coaxially with respect to the bearing section 11 about the web section 12, and V-shaped grooves 14 which are formed on the outer circumference of the rim section 13. The bearing section 11, web section 12, rim section 13 and V-shaped grooves 14 are formed integrally by cold working.

A plurality of the V-shaped grooves 14 are so-called poly-V-shaped grooves. The respective V-shaped grooves 14 are formed symmetrically with respect to the web section 12. Moreover, the inner circumferential surface of the bearing section 11 is engaged with a bearing (not shown) similarly to the conventional example.

Next, the description will be given as to the manufacturing method of the aforementioned pulley 10 on reference to FIGs. 3 through 9. First, a cylindrical iron material W1 shown in FIG. 3 is cold-forged (cold-worked) by press so that a thick circular plate W2 shown in FIG. 4 is formed. Then, as shown in FIG. 5, a central portion of the thick circular plate W2 is crushed in a circular shape from the top and bottom surfaces by the cold forging using press, and a circular thin section W2a is formed. As shown in FIG. 6, the circular thin section W2 is blanked by press so that a thick ring body W3 is formed.

Thereafter, as shown in FIG. 7, a middle portion of the thick ring body W3 in a radial direction is crushed from the top and bottom surfaces by the cold forging using press so that the bearing section 11 is formed on the inner circumference of the thick ring body W3, the web section 12 is formed on the middle portion and a redundant section W4a used for forming the rim section 13 is formed on the outer circumference. Namely, a rough shaped section W4 of the pulley is formed. As shown in FIG. 8, the rough shaped section W4 is cold-forged by a bottom die M1, top die M2, inner circumference holding die M3 and outer circumference holding die M4.

Next, as shown in FIG. 9, while the bearing section 11 and web section 12 are being held by a lower surface holding die M5, upper surface holding die M6 and inner circumference holding die M7, the rim section 13 and V-shaped grooves 14 are rolled from the outer circumferential surface and cold-formed by using a roller die M8. As a result, the pulley 10 is finished.

In the pulley 10 arranged in the above manner, since the web section 12 connects the central portion of the bearing section 11 to the central portion of the rim section 13, the tension of the belt is applied to the V-shaped grooves 14. As a result, even if bending moment is generated, the bending moment is weak. Furthermore, since the V-shaped grooves 14 are provided symmetrically with respect to the web section 12, the bending moment is balanced at the rim section 13. For this

reason, the bending moment can be prevented from being applied to the web section 12 and bearing section 11. Therefore, the whole portion is difficult to deflect, and thus vibration and noise can be reduced, and durability of a bearing can be improved. Further, in this pulley 10, since a width between the bearing section 11 and the rim section 13 with which a bearing is engaged, i.e., a width of the web section 12 can be narrowed, an outer diameter of the rim section 13 can be small, and thus the pulley which is specially suitable to a pulley with small diameter can be obtained.

In addition, since a layered structure is obtained by a series of cold working and strength is increased due to hardening by the cold forging, the durability can be further improved, and thus the thickness of the whole structure can be small. Therefore, the cost can be reduced. Further, since surface accuracy is improved by the cold forging, steps for finishing the inner surface of the bearing section 11 and the V-shaped grooves 14, for example, can be omitted, and this can also reduce the cost. Namely, the productivity can be improved.

Furthermore, in the cold forging step, since the rim section 13 can be formed so as to have an enough thickness to form the V-shaped groove 14 as the redundant section W4a, the step of increasing a thickness in the conventional example is not required. Therefore, the cost can be reduced. Moreover, since the yield is improved by the cold forging, the material costs can be reduced.

Next, the description will be given as to the second embodiment of the present invention on reference to FIGs. 10 through 12. However, the same reference numerals are given to the components which are common to the aforementioned first embodiment, and the description thereof is simplified. A point of the second embodiment different from the first embodiment is that a stopper 11a for a bearing is formed integrally with the bearing section 11.

Namely, as shown in FIG. 10, an annular stopper 11a which is bent from one end in its axial direction towards the inner side is formed at the bearing section 11. As shown in FIG. 11, the stopper 11a is formed by cold forging at the step of forming the rough shaped section W4 of the pulley. Moreover, as shown in FIG. 12, the rim section 13 and V-shaped grooves 14 are formed by the roller die M8 with the bearing section 11 including the stopper 11a and the web section 12 being held by the dies M5, M6 and M7.

In the pulley 10 structured in the above manner, since the rough shaped section W4 of the pulley can be formed by the cold forging and at the same time the inner surface of the bearing section 11 and the stopper 11a can be formed accurately, a bearing is engaged directly with the bearing section 11, and the bearing can be positioned. Therefore, the productivity can be improved.

Next, the description will be given as to the third embodiment of the present invention on reference to FIGs. 13 through 16. However, the same reference numerals

are given to the components which are common to the aforementioned first embodiment, and the description thereof is simplified. A point of the third embodiment which is different from the first embodiment is that the thickness of the web section 12 becomes thicker gradually with directing towards the bearing section 11 and the rim section 13.

Namely, as shown in FIGs. 13 and 14, the web section 12 is formed so that its thickness becomes thicker gradually with directing towards the bearing section 11 and rim section 13 on a circularly arced surface.

The web section 12 formed in such a manner, as shown in FIG. 15, is formed by cold forging at the step of forming the rough shaped section W4 of the pulley. When the web section 12 is cold-forged, the material positioned in the web section 12 is easy to flow to the sides of the bearing section 11 and rim section 13. Moreover, as shown in FIG. 16, the rim section 13 and V-shaped grooves 14 are formed by the roller die M8 with the bearing section 11 and web section 12 being held by the dies M5, M6 and M7.

In the pulley 10 structured in the above manner, since the web section 12 is formed so that its thickness becomes thicker gradually with directing towards the bearing section 11 and rim section 13 on a circularly arced surface, when the web section 12 is cold-forged, the material positioned in the web section 12 is easy to flow towards the bearing section 11 and rim section 13. Therefore, a force and time required for cold forging can be reduced. Moreover, since the thickness of a portion requiring strength can be increased easily and the thickness of a portion which does not require strength can be reduced easily, the strength and light-weighting of the pulley 10 can be improved.

In the aforementioned embodiments, a plurality of the V-shaped grooves 14 are provided, but only one V-shaped groove 14, namely, a so-called mono-V-shaped groove may be provided. However, it is preferable that the mono-V-shaped groove is formed symmetrically with respect to the web section 12. Further, the V-shaped grooves 14 may be arranged by combining the mono-V-shaped groove and poly-V-shaped groove. Namely, both the mono-V-shaped groove and poly-V-shaped groove may be provided to the rim section 13.

In addition, also in the third embodiment, a stopper for a bearing may be provided.

Next, the description will be given as to the fourth embodiment of the present invention on reference to FIGs. 17 and 18. However, the same reference numerals are given to the components which are common to the first embodiment, and the description thereof is omitted. A point of the fourth embodiment different from the first embodiment is that the thick ring body W3 is formed by pressing a plate-shaped material W0.

As shown in FIG. 18, the ring-shaped thick ring body W2 is formed by blanking the thick plate-shaped material W0 by press. When a middle portion in the radial direction of the thick ring body W2 is crushed in the sim-

ilar manner to the first embodiment, the rough shaped section W4 of the pulley is formed. Since the forming structure hereafter is the same as that in the first embodiment, the description thereof is omitted.

According to the fourth embodiment, since the thick ring body W2 can be formed by blanking the plate-shaped material W0 by press, the thick ring body W2 can be formed only by press. As a result, the manufacturing steps can be simplified, the productivity can be improved, and thus the cost can be reduced.

Here, the thick circular plate body W2 obtained when the thick ring body is formed may be broken as scrap, but similarly to the thick circulate plate body W2 shown in the first embodiment, after the central portion of the thick circulate plate body W2 is crushed from the top and bottom surfaces in a circulate shape by cold forging using press and a circular thin section W2a is formed, the thick ring body W3 is formed by blanking the circular thin section W2a using press so as to be used. As a result, the material can be used effectively, and thus the cost can be reduced.

While preferred embodiments of the present invention have been described using specific terms, such description is for illustrative purposes, and it is to be understood that changes and variations may be made without departing from the spirit or scope of the following claims.

## 30 Claims

### 1. A pulley comprising:

an inner cylindrical section;  
 a web section which is extended from a central portion in an axial direction of said inner cylindrical section;  
 an outer cylindrical section which is formed at an outer circumferential portion of said web section coaxially with respect to said inner cylindrical section about said web section; and  
 V-shaped grooves which are formed on an outer circumference of said outer cylindrical section are formed integrally by cold working.

2. The pulley according to claim 1, wherein said web section is formed so that its thickness becomes thicker gradually with directing towards said inner cylindrical section and outer cylindrical section.

3. The pulley according to claim 1, wherein the inner cylindrical section is formed with a bearing stopper.

4. A manufacturing method of a pulley, comprising the steps of:

forming a web section on a middle portion in a radial direction of a thick ring body by crushing

the middle portion by cold working;  
forming an inner cylindrical section at an inner  
circumferential portion of said web section, a  
central portion of said inner cylindrical section  
being said web section; 5  
forming a redundant section at the outer cir-  
cumferential portion of said web section, a cen-  
tral portion of said redundant section being said  
web section; and  
forming an outer cylindrical section having V- 10  
shaped grooves on its outer circumferential  
portion, said outer cylindrical section being  
formed at the outer circumferential portion of  
said web section coaxially with respect to said 15  
inner cylindrical section about said web section  
by cold-working V-shaped grooves on an outer  
circumference of said redundant section.

5. The manufacturing method of a pulley according to  
claim 4, wherein said thick ring body is formed such 20  
that a thick circulate plate body is formed by crush-  
ing a cylindrical material by cold working, that a cir-  
cular thin section is formed by crushing a central  
portion of the thick circular plate body in a circular  
shape by cold working, and that the circular thin 25  
section is blanked by press.
6. The manufacturing method of a pulley according to  
claim 4, wherein said thick ring body is formed by 30  
blanking a plate shaped material by press.
7. The manufacturing method of a pulley according to  
claim 4, wherein said web section is formed by  
crushing a central portion in a radial direction of the 35  
thick ring body by cold working so that its thickness  
becomes thicker gradually with directing towards  
said inner cylindrical section and outer cylindrical  
section.
8. A pulley (10) comprising web means (12) connect- 40  
ing respective coaxial centres of inner cylindrical  
means (11) and outer cylindrical means (13), the  
outer cylindrical means (13) having at least one out-  
wardly facing groove ( 14 ). 45
9. A method of manufacturing a pulley (10) by press-  
ing a thick ring (W3) to form web means (12) con-  
necting respective coaxial centres of inner cylindri-  
cal means (11) and outer cylindrical means (13) and 50  
pressing the outer cylindrical means (13) to form at  
least one outwardly facing groove (14).

55

**FIG.1**  
PRIOR ART

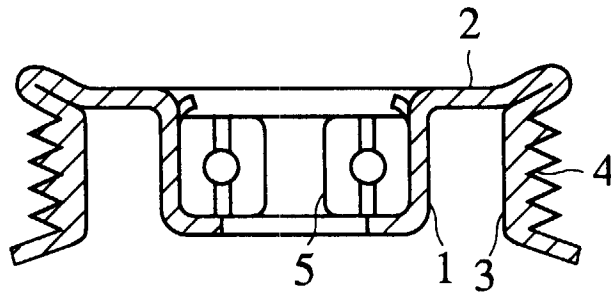

FIG.2

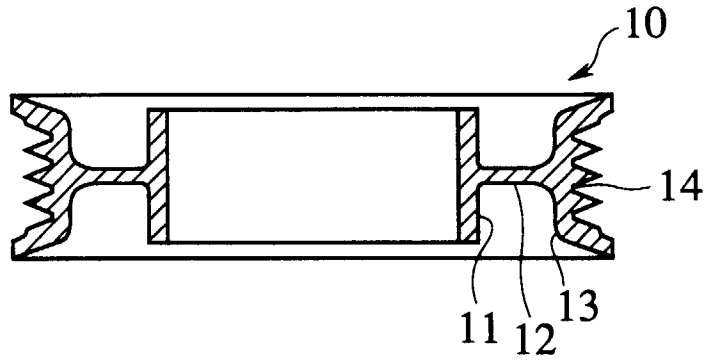

FIG.3

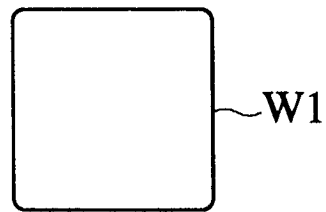

FIG.4

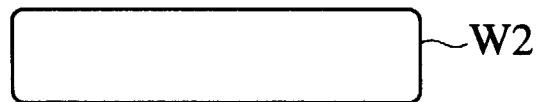

FIG.5

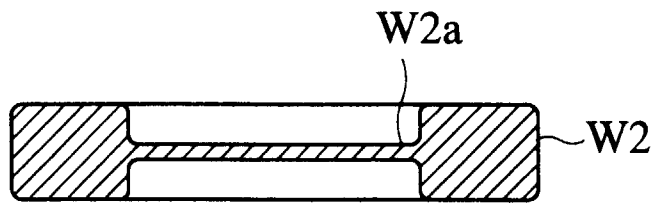

FIG.6



FIG.7

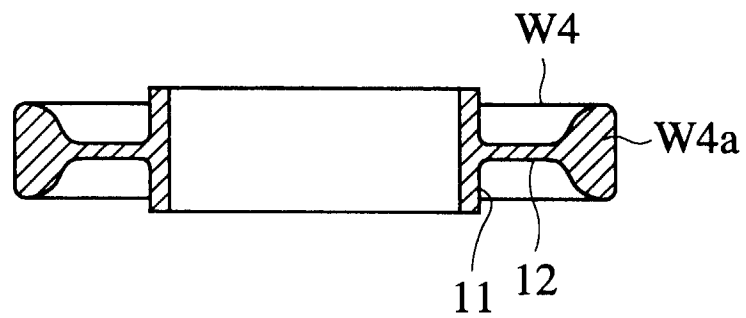

FIG.8

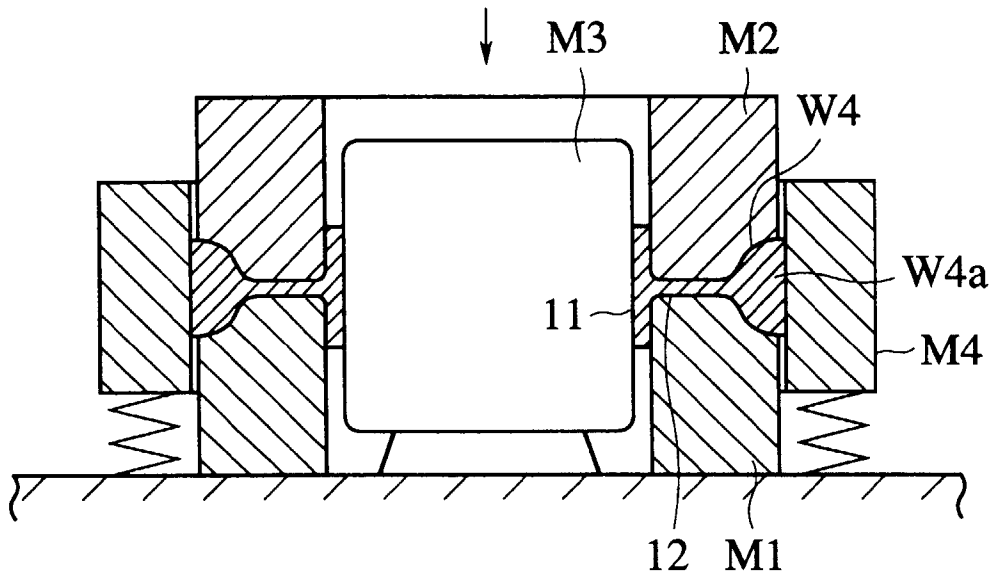

FIG.9

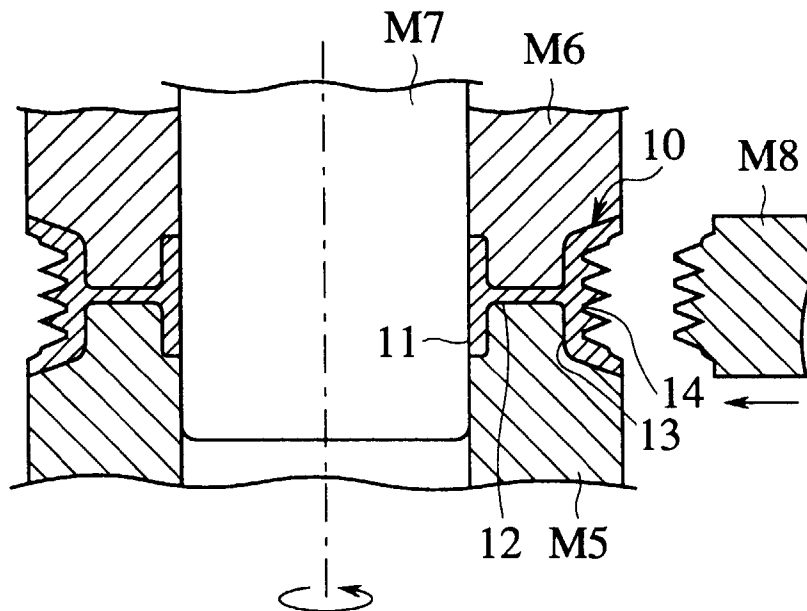

FIG. 10

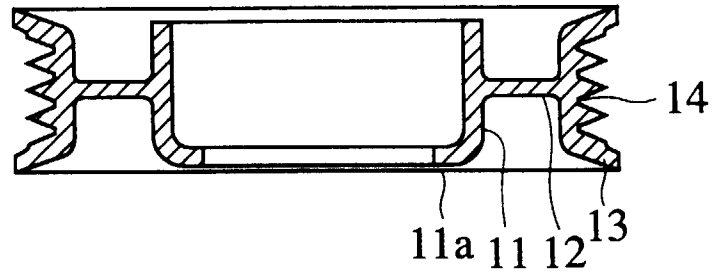

FIG. 11

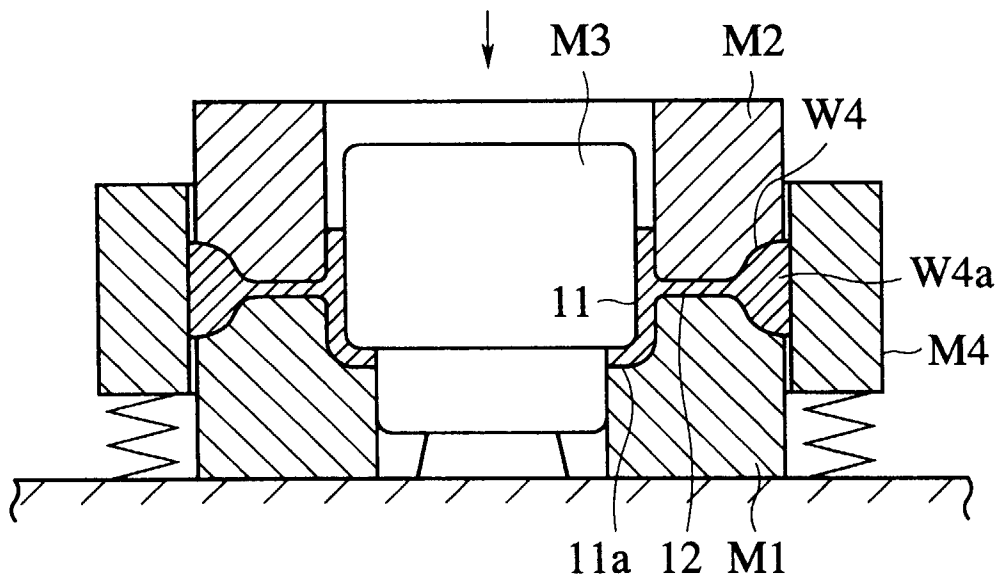

FIG.12

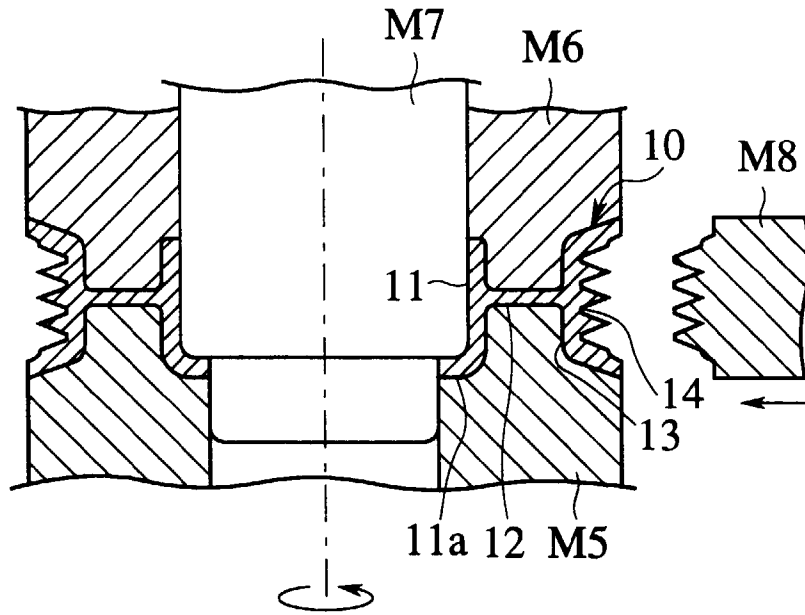

FIG.13

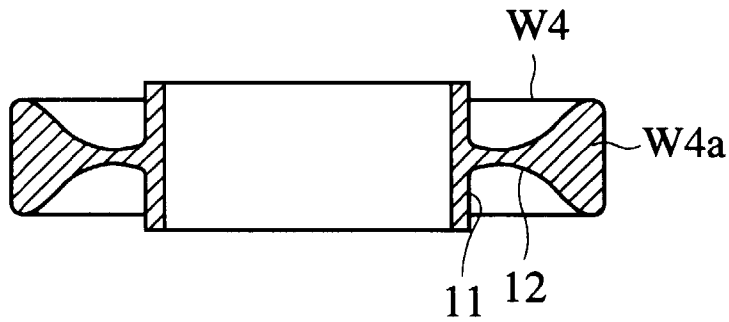

FIG.14

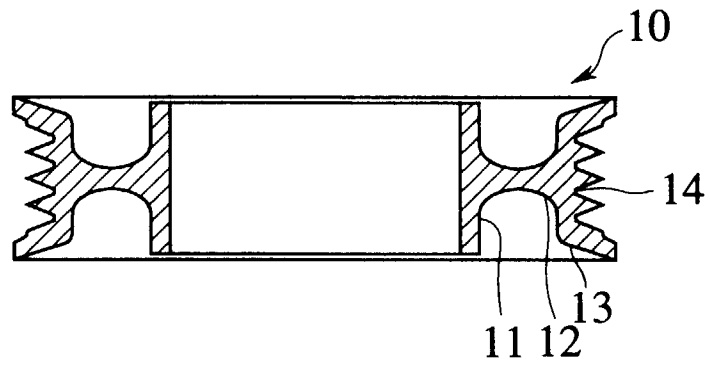

FIG.15

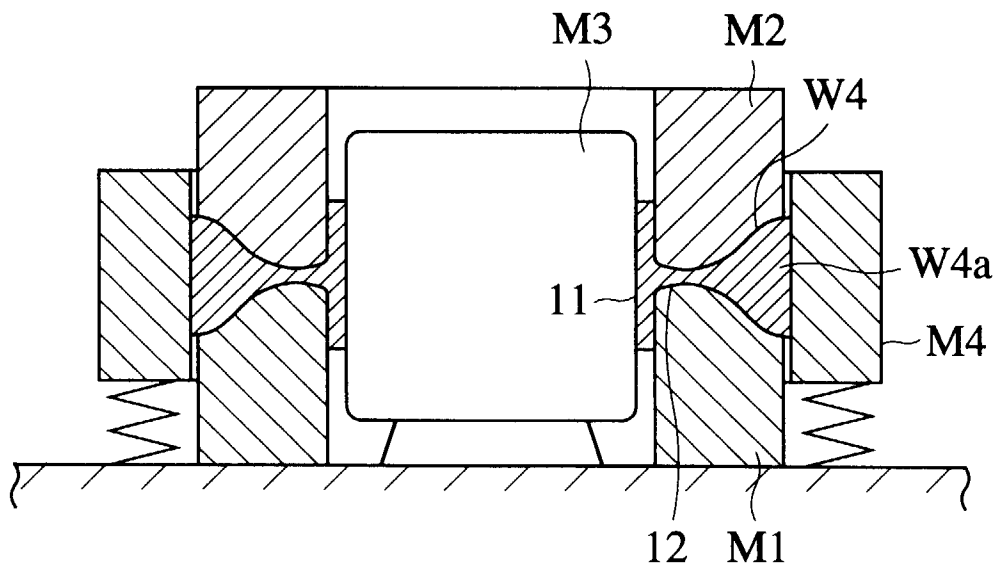

FIG. 16

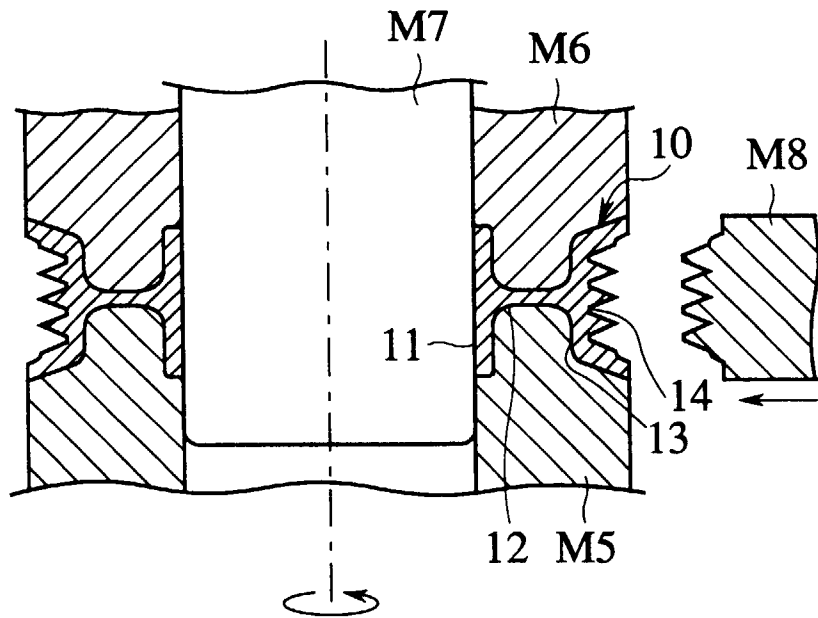

FIG.17

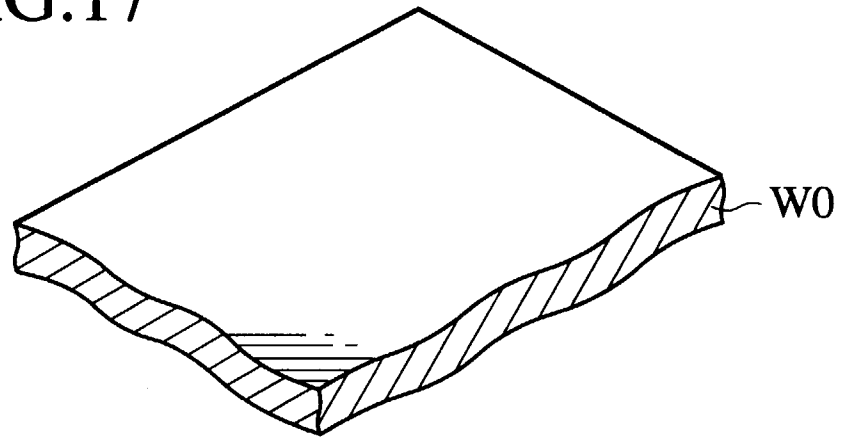
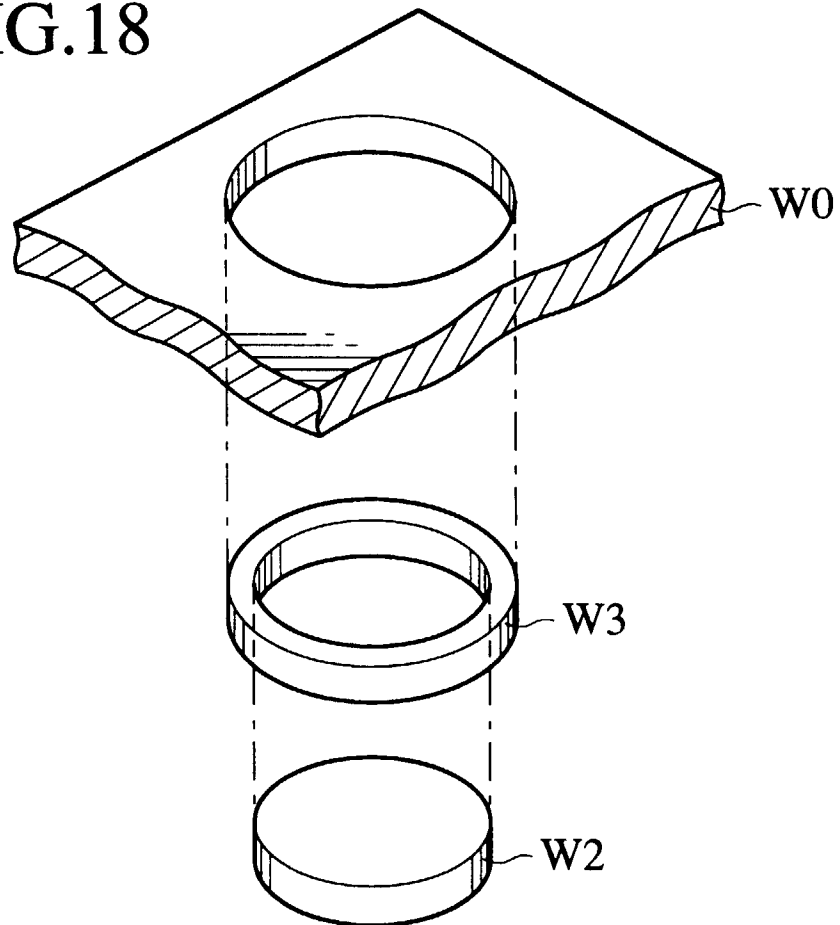

FIG.18





European Patent  
Office

EUROPEAN SEARCH REPORT

Application Number  
EP 97 31 0601

DOCUMENTS CONSIDERED TO BE RELEVANT			
Category	Citation of document with indication, where appropriate, of relevant passages	Relevant to claim	CLASSIFICATION OF THE APPLICATION (Int.Cl.6)
X Y	US 4 767 387 A (MATSUOKA ET AL.) * the whole document *	1-3,8 4-7,9	F16H55/36
---			
Y A	FR 2 527 953 A (DUCELLIER & CIE) * the whole document *	4-7,9 1-3,8	
---			
Y	US 4 905 361 A (MORISHITA AKIRA ET AL) * the whole document *	1-9	
---			
Y	US 5 163 883 A (BRADFIELD MICHAEL D) * the whole document *	1-9	
---			
A	US 4 697 445 A (TANAKA HARUMA ET AL) * the whole document *	1	
---			
A	US 3 807 246 A (MCILLWAIN J) * the whole document *	1	
-----			
			TECHNICAL FIELDS SEARCHED (Int.Cl.6)
			F16H B21K B21D
The present search report has been drawn up for all claims			
Place of search <b>BERLIN</b>		Date of completion of the search <b>15 April 1998</b>	Examiner <b>von Arx, H</b>
CATEGORY OF CITED DOCUMENTS		T : theory or principle underlying the invention E : earlier patent document, but published on, or after the filing date D : document cited in the application L : document cited for other reasons & : member of the same patent family, corresponding document	
X : particularly relevant if taken alone Y : particularly relevant if combined with another document of the same category A : technological background O : non-written disclosure P : intermediate document			

EPO FORM 1503 03.82 (P04C01)