

(12) STANDARD PATENT APPLICATION (11) Application No. **AU 2006200831 A1**
(19) AUSTRALIAN PATENT OFFICE

(54) Title
Gaming settlement machine, gaming terminal machine and gaming identification system

(51) International Patent Classification(s)
G06F 17/30 (2006.01)

(21) Application No: **2006200831** (22) Date of Filing: **2006.02.27**

(30) Priority Data

(31) Number **2005-059326** (32) Date **2005.03.03** (33) Country **JP**

(43) Publication Date: **2006.09.21**

(43) Publication Journal Date: **2006.09.21**

(71) Applicant(s)
Aruze Corp.

(72) Inventor(s)
Fujimoto, Jun

(74) Agent / Attorney
Davies Collison Cave, 1 Nicholson Street, MELBOURNE, VIC, 3000

ABSTRACT OF THE DISCLOSURE (FIG.2)

A gaming identification system (300) comprises a gaming settlement machine (1) and a gaming terminal machine (100) connected to the gaming settlement machine (1). The gaming settlement machine (1) generates a player image data for identifying a player who will obtain a payout, and then sends the player image data to the gaming terminal machine (100). The gaming settlement machine (1) executes the payout according to a payout order data for ordering whether or not the gaming settlement machine (1) is permitted to execute the payout to the player who is identified, when receiving it from the gaming terminal machine (100). The gaming terminal machine (100) displays a player's image according to the player image data sent from the gaming settlement machine (1). The gaming terminal machine (100) generates the payout order data according to the displayed player's image, and then sends the payout order data to the gaming settlement machine (1).

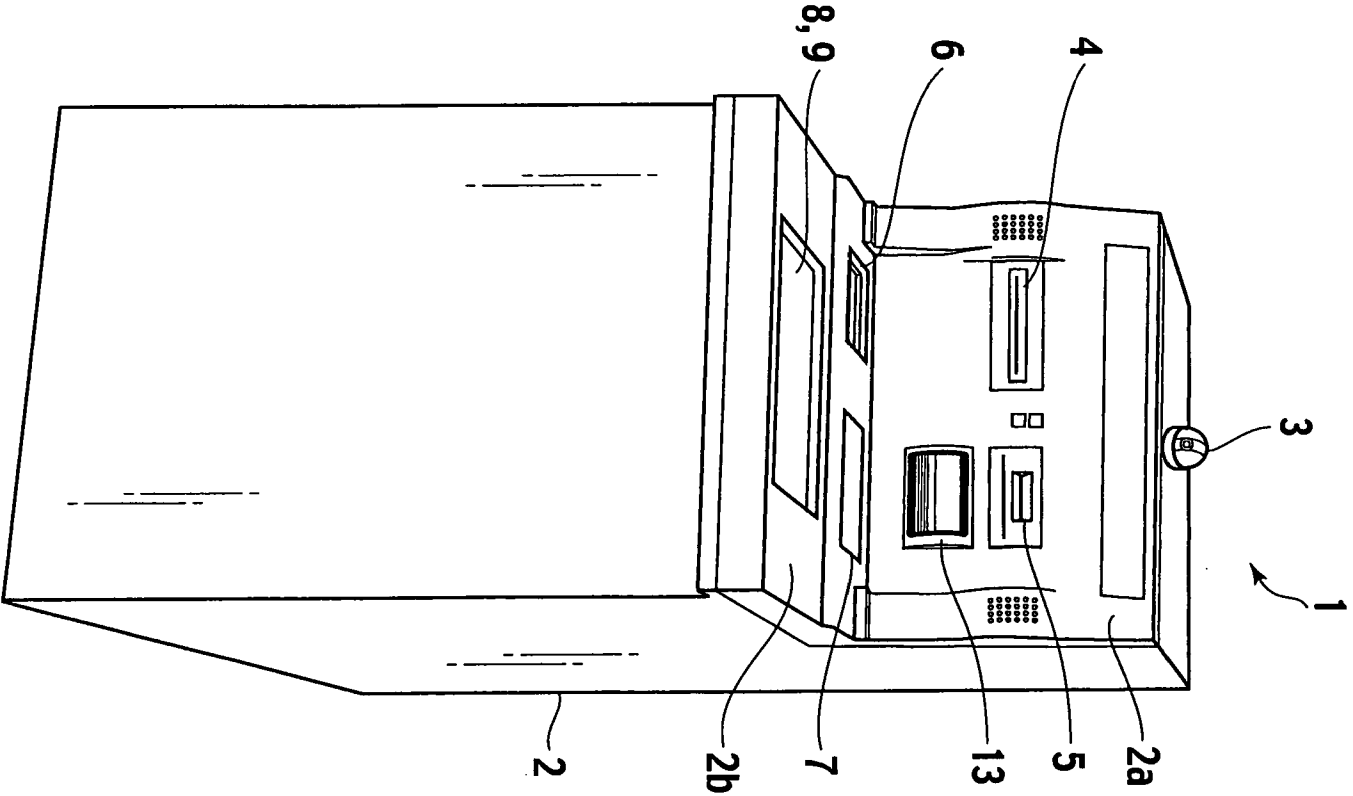

FIG. 1

2006200831 27 Feb 2006

AUSTRALIA
PATENTS ACT 1990
COMPLETE SPECIFICATION

NAME OF APPLICANT(S)::

Aruze Corp.

ADDRESS FOR SERVICE:

DAVIES COLLISON CAVE
Patent Attorneys
1 Nicholson Street, Melbourne, 3000, Australia

INVENTION TITLE:

Gaming settlement machine, gaming terminal machine and gaming identification system

The following statement is a full description of this invention, including the best method of performing it known to me/us:-

BACKGROUND OF THE INVENTION

5 **1. Field of the Invention**

The present invention relates to a gaming settlement machine configured to execute a payout according to a winning mode, a gaming terminal machine connected to the gaming settlement machine, and a gaming identification system including the gaming settlement machine and the gaming terminal machine.

2. Description of the Related Art

15 There have been lots of gaming machines that pay out one or more game media such as medals or coins, according to a winning mode. A card gaming machine or a slot machine has been known as the gaming machine. The card gaming machine displays a playing card image thereon and then executes the card game while variably displaying the playing card image according to a player's operation. The slot machine includes mechanical reels of which symbols are mounted on a peripheral surface or video reels on which symbol images are displayed.

25 A conventional slot machine is disclosed in Japanese Patent Laid-open Publication No. 2000-42169. When a player carries out a predetermined operation, the slot machine rotates mechanical reels and then determines whether or not the player

wins in a current game by comparing a symbol combination which is obtained on a predetermined payline at a time of stopping the mechanical reels, with predetermined winning combinations. If the player wins, a winning mode is established on the basis of the obtained symbol combination.

The slot machine varies the number of game media to be paid out, according to an established winning mode. There is a special winning mode among the winning modes. If the special winning mode is established, the slot machine pays out a large number of game media in comparison with other winning modes.

In a case where the gaming machine is located in a country or a region where a special winning mode in which a player can obtain game media corresponding to a money amount equal to or more than a predetermined money amount (e.g. 1200 dollars) is subject to taxation, the player must pay his/her tax when obtaining the special winning mode. This tax payment process stops the gaming machine's execution before the game media are ejected from the gaming machine. In the tax payment process, a game-hall agent identifies the player and causes the player to sign a predetermined document.

The tax payment process mainly has the following problems:
(1) it takes about an hour to carry out the tax payment process because the game-hall agent identifies the player personally; and (2) measurable consumption of electrical power occurs because the gaming machine waits until the tax payment process is completed.

SUMMARY OF THE INVENTION

It is an object of the present invention to provide a gaming settlement machine, a gaming terminal machine, and a gaming identification system all capable of shortening an identification time in a payout process including a tax payment process to reduce a waiting time for a player and electrical power consumption of a gaming machine.

In order to achieve the object, the present invention provides a gaming settlement machine comprising: a payout unit configured to execute a payout according to a winning mode; an image data generating unit configured to generate a player image data for identifying a player who is associated with the payout; a sending control unit configured to send the player image data to an outside terminal machine; a receiving unit configured to receive from the outside terminal machine a payout order data for ordering whether or not the payout unit is permitted to execute the payout to the player; and a payout control unit configured to allow the payout unit to execute the payout on the basis of the payout order data.

According to the present invention, an identification time can be shortened, which reduces a waiting time for a player and electrical power consumption of a gaming machine.

In order to achieve the object, the present invention provides a gaming terminal machine comprising: a display unit configured to display an image; a display control unit configured

to allow the display unit to display a player's image by means of a player image data for identifying a player who is associated with a payout, which is sent from a gaming settlement machine configured to execute the payout according to a winning mode; 5 a payout order data generating unit configured to generate a payout order data for ordering whether or not the gaming settlement machine is permitted to execute the payout to a player who is identified on the basis of the displayed player's image; and a sending control unit configured to send the payout order 10 data to the gaming settlement machine.

According to the present invention, an identification time can be shortened, which reduces a waiting time for a player and electrical power consumption of a gaming machine.

In order to achieve the object, the present invention 15 provides a gaming identification system comprising: a gaming settlement machine; and a gaming terminal machine connected to the gaming settlement machine, wherein the gaming settlement machine comprises: a payout unit configured to execute a payout according to a winning mode; an image data generating unit 20 configured to generate a player image data for identifying a player who is associated with the payout; a sending control unit configured to send the player image data to the gaming terminal machine; a receiving unit configured to receive from the gaming terminal machine a payout order data for ordering 25 whether or not the payout unit is permitted to execute the payout to the player who is identified; and a payout control unit

configured to allow the payout unit to execute the payout on the basis of the payout order data, wherein the gaming terminal machine comprises: a display unit configured to display an image; a display control unit configured to allow the display unit to display a player's image by means of the player image data sent from the gaming settlement machine; a payout order data generating unit configured to generate the payout order data on the basis of the displayed player's image; and a sending control unit configured to send the payout order data to the gaming settlement machine.

According to the present invention, an identification time can be shortened, which reduces a waiting time for a player and electrical power consumption of a gaming machine.

BRIEF DESCRIPTION OF THE DRAWINGS

FIG. 1 is a perspective view of a gaming settlement machine according to an exemplary embodiment of the present invention.

FIG. 2 is a block diagram of a gaming identification system according to the exemplary embodiment of the present invention.

FIG. 3 is a block diagram of the gaming settlement machine according to the exemplary embodiment of the present invention.

FIG. 4 is a block diagram of a gaming terminal machine according to the exemplary embodiment of the present invention.

FIG. 5 is a perspective view of a slot machine according to the exemplary embodiment of the present invention.

FIG. 6 is a block diagram of the slot machine according

to the exemplary embodiment of the present invention.

FIG.7 is a block diagram of an image control circuit incorporated into the slot machine according to the exemplary embodiment of the present invention.

5 FIG.8 is a flowchart of a main process from an operation start to an operation end of the slot machine according to the exemplary embodiment of the present invention.

FIG.9 is a flowchart of a sortition process according to the exemplary embodiment of the present invention.

10 FIG.10 is a flowchart of a main process from an operation start to an operation end of the gaming settlement machine according to the exemplary embodiment of the present invention.

FIG.11 is a flowchart of a payout process according to the exemplary embodiment of the present invention.

15 FIG.12 is a flowchart of a main process from an operation start to an operation end of the gaming terminal machine according to the exemplary embodiment of the present invention.

FIG.13 is a tax payment confirmation screen according to the exemplary embodiment of the present invention.

20 FIG.14 is a flowchart of a manual tax payment process according to the exemplary embodiment of the present invention.

FIG.15 is a block diagram of a gaming identification system according to a first modified example in the exemplary embodiment of the present invention.

25 FIG.16 is a block diagram of a gaming server according to the first modified example in the exemplary embodiment of

the present invention.

FIG.17 is a block diagram of a gaming identification system according to a second modified example in the exemplary embodiment of the present invention.

DESCRIPTION OF THE PREFERRED EMBODIMENTS

Hereinafter, an exemplary embodiment of the present invention will be described with reference to FIGS.1 to 17.

10 (Configuration of gaming identification system)

As shown in FIG.2, a gaming identification system 300 comprises a gaming settlement machine 1, a gaming terminal machine 100, a slot machine 200 and networks N1, N2. The gaming settlement machine 1 is connected to the slot machine 200 via the network N1 to communicate with the slot machine 200. The gaming settlement machine 1 is also connected to the gaming terminal machine 100 via the network N2 to communicate with the gaming terminal machine 100. The networks N1, N2 are LAN (local area network), Internet or the like.

20 The gaming identification system 300 has winning information IN1 to be sent from the slot machine 200 to the gaming settlement machine 1 via the network N1, player image data P1, P2 to be sent from the gaming settlement machine 1 to the gaming terminal machine 100 via the network N2, and payout order data IN2 to be sent from the gaming terminal machine 100 to the gaming settlement machine 1 via the network N2. The

winning information IN1, the player image data P1, P2, and the payout order data IN2 will hereinafter be described in detail. In the gaming identification system 300, a game-hall agent (operator) can easily confirm the player's identity to be displayed on the gaming terminal machine 100 on the basis of the player image data P1, P2 sent from the gaming settlement machine 1.

(Configuration of gaming settlement machine)

The gaming settlement machine 1 executes a payout according to a gaming winning combination, and a tax payment process in a case where a winning mode is a special winning mode to be subject to taxation. As shown in FIG.1, the gaming settlement machine 1 comprises a cabinet 2, a CCD (charge-coupled device) camera 3, a passport insertion slot 4, a card insertion slot 5, a coin ejection slot 6, a bill ejection slot 7, a liquid crystal display panel 8, a touch panel 9 and a barcode reader 13.

The cabinet 2 forms the entirety of the gaming settlement machine 1 and includes a front panel 2a and a base panel 2b. The base panel 2b forward extends from a lower part of the front panel 2a.

The CCD camera 3 is an image taking means for taking a face image of a player who will obtain the payout according to the gaming winning combination in the slot machine 300. The CCD camera 3 is mounted on a head step of the front panel 2a.

The CCD camera 3 has a lens capable of rotating in a vertical direction and a horizontal direction thereof according to a height and a position of the player who stands so as to be opposed to a front side of the gaming settlement machine 1. The imaged face data is input into a main CPU 22 via an I/O port 25 (see FIG.3). The main CPU 22 operates as an image data generating means to generate the player image data P1 which will be employed to confirm the palyer's identity.

The passport insertion slot 4, the card insertion slot 5 and the barcode reader 13 are mounted on a front face of the front panel 2a so as to be opposed to the player. The passport insertion slot 4 is an insertion slot into which a passport 10 (player identification document) will be inserted. The passport insertion slot 4 has a scanner 4a therein. The card insertion slot 5 is an insertion slot into which an ID card 11 storing a player ID (e.g. personal information or membership information) therein will be inserted. The card insertion slot 5 has a card reader 5a for reading the player ID stored in the ID card 11 therein. The barcode reader 13 reads data (e.g. winning information IN1 and player ID) stored in a barcode (e.g. JAN code or two-dimensional code) printed on a receipt 12. The receipt 12 is issued from the slot machine 200 when the slot machine 200 determines the player wins the game. These read data is input into the main CPU 22 via the I/O port 25 (see FIG.3).

The coin ejection slot 6 and the bill ejection slot 7

are mounted on a rear side of the base panel 2b. The main CPU 22 ejects coins and/or bills corresponding to a dividend amount from the coin ejection slot 6 and/or the bill ejection slot 7. The liquid crystal display panel 8 is mounted on a front side of the base panel 2b. The liquid crystal display panel 8 displays a selection screen and the like for causing the main CPU 22 to execute a predetermined operation in a payout and a predetermined procedure in a payout process. The payout process will hereinafter be described in detail.

The touch panel 9 covers the selection screen and the like displayed by the liquid crystal display panel 8. The touch panel 9 detects a touch position where a player's finger is laid and then inputs a touch position signal to the main CPU 22. The touch panel 9 includes an image generating portion 9a for generating image data of characters and/or marks (e.g. an autograph sign and/or a finger mark of the player) entered by an electronic pen (not shown).

As shown in FIG. 3, the gaming settlement machine 1 further comprises the scanner 4a, the card reader 5a, a microcomputer 21, the I/O port 25, a communication control unit 26, a communication process unit 27, a coin hopper driving circuit 28a, a coin hopper 28b, a coin counting unit 28c, a coin ejection complete signal circuit 28d, a bill ejection device driving circuit 29a, a bill ejection device 29b, a bill counting unit 29c, a bill ejection complete signal circuit 29d and an image control circuit 30.

The microcomputer 21 has the main CPU (Central Processing Unit) 22, a RAM (Random Access Memory) 23 and a ROM (Read Only Memory) 24. The main CPU 22 operates on programs stored in the ROM 24 and receives/sends various signals from/to other
5 constructional elements via the I/O port 25, which controls the gaming settlement machine 1. The RAM 23 temporarily stores programs and/or data employed by the main CPU 22. The ROM 24 perpetually stores the programs and data to be employed by the main CPU 22.

10 The scanner 4a is an image reading means for reading a page, on which a facial photograph is printed, of the passport
10 inserted into the passport insertion slot 4 and then inputting the read image data (scan data) to the main CPU 22 via the I/O port 25. When the main CPU 22 receives the scan data, the main
15 CPU 22 operates as the image data generating means to generate the player image data P2 which will be employed to confirm the player identity, on the basis of the scan data. The card reader
5a reads the player ID stored in the ID card 11 which is inserted into the card insertion slot 5 and then inputs the read player
20 ID into the main CPU 22 via the I/O port 25.

The communication control unit 26 operates according to an order of the main CPU 22 to control a line connection and a line disconnection between the gaming settlement machine 1 and the gaming terminal machine 100 or the slot machine 200.
25 The communication process unit 27 operates according to an order of the communication control unit 26 to receive the winning

information IN1 and the payout order data IN2 via the network N1, N2 and send the player image data P1, P2 generated by the main CPU 22.

5 The coin hopper driving circuit 28a drives the coin hopper 28b according to a control of the main CPU 22. The coin hopper 28b operates to eject one or more coins corresponding to a dividend amount. The coin counting unit 28c counts the number of coins ejected from the coin hopper 28b and then notifies the coin ejection complete signal circuit 28d of the counted
10 number of coins. The coin ejection complete signal circuit 28d inputs a coin ejection complete signal into the main CPU 22 if the counted number attains to a value of equal to or more than a predetermined number.

15 The bill ejection device driving circuit 29a drives the bill ejection device 29b according to a control of the main CPU 22. The bill ejection device 29b operates to eject one or more bills corresponding to a dividend amount. The bill counting unit 29c counts the number of bills ejected from the bill ejection device 29b and then notifies the bill ejection
20 complete signal circuit 29d of the counted number of bills. The bill ejection complete signal circuit 29d inputs a bill ejection complete signal into the main CPU 22 if the counted number attains to a value of equal to or more than a predetermined number.

25 The image control circuit 30 controls an image display of the liquid crystal display panel 8, which allows the liquid

crystal display panel 8 to display the selection screen and the like for causing the main CPU 22 to execute a predetermined operation in a payout and a predetermined procedure in a payout process.

5
(Configuration of gaming terminal machine)

As shown in FIG.4, the gaming terminal machine 100 comprises a main body 110, a display 107 and an operation unit 108. The main body 110 incorporates a CPU 101, a ROM 102, a RAM 103, 10 a communication control unit 104, a communication process unit 105 and an image control unit 106 therein. The gaming terminal machine 100 is connected to the gaming settlement machine 1 via the network N2.

The CPU 101 operates on programs stored in the ROM 102 15 to control the gaming terminal machine 100. When identifiable information or unidentifiable information is input into the CPU 101 from the operation unit 108, the CPU 101 operates as a payout order data generating means to generate the payout order data IN2. The payout order data IN2 includes payout 20 permission information for permitting the gaming settlement machine 1 to pay out conins and/or bills to a player or payout prohibition information for prohibiting the gaming settlement machine 1 from paying out the conins and/or the bills to the player. The ROM 102 perpetually stores the programs and data 25 to be employed by the CPU 101. The RAM 103 temporarily stores programs and/or data employed by the CPU 101.

The communication control unit 104 operates according to an order of the CPU 101 to control a line connection and a line disconnection between the gaming terminal machine 100 and the gaming settlement machine 1. The communication process unit 5 105 operates according to an order of the communication control unit 104 to receive the player image data P1, P2 via the network N2 and send the payout order data IN2 generated by the CPU 101.

The image control unit 106 operates as a display control means to display player images on the display 107 by means of 10 the player image data P1, P2 sent from the gaming settlement machine 1 via the network N2. The display 107 operates as a display means to display the image data by the CCD camera 3 on the basis of the player image data P1 and the scan data by the scanner 4a on the basis of the player image data P2. The 15 operator can identify a player by comparing the image data with the scan data.

The operation unit 108 is a keyboard, a mouse or the like and operates as an operation means. In the embodiment, the operation unit 108 is the mouse. The operator inputs into the 20 CPU 101 the identifiable information for informing that a player is identified by operating the operation unit 108 (e.g. clicking with the mouse an "IDENTIFY OK" button provided on the display 107) when identifying the player on the basis of the image data and the scan data. The operator inputs into the CPU 101 the 25 unidentifiable information for informing that a player is not identified by operating the operation unit 108 (e.g. clicking

with the mouse an "IDENTIFY NG" button provided on the display 107) when not identifying the player on the basis of the image data and the scan data.

5 (Configuration of slot machine)

The slot machine 200 variably displays a plurality of symbols on a variable display means by rotating video reels. The slot machine 200 executes a game by variably displaying the symbols on the variable display means and then determines 10 whether or not a symbol combination generated on one or more predetermined paylines at a time of stopping the video reels is a gaming winning combination.

As shown in FIG.5, the slot machine 200 comprises a cabinet 201, liquid crystal display panels 202, 203, 204, a coin insertion 15 slot 205, a bill insertion slot 206, an ID card insertion slot 207, an issue slot 208, a spin button 209, BET selection buttons 210, line selection buttons 211 and an issue button 213.

The cabinet 201 forms the entirety of the slot machine 200. The liquid crystal display panels 202, 203, 204 are mounted 20 on the cabinet 201. The liquid crystal display panel 202 displays thereon an image (e.g. a three-dimensional effect image for bringing lots of excitement to the game or a dividend table) which is directly uninvolved in the game. The liquid crystal display panel 203 displays a game execution method or the like 25 thereon. The liquid crystal display panel 204 variably displays the plurality of symbols thereon by rotating the video reels.

The coin insertion slot 205, the bill insertion slot 206, the ID card insertion slot 207 and the issue slot 208 are mounted on the cabinet 201 to be located below the liquid crystal display panel 204. A player can insert coins to be bet on the game into the slot machine 200 via the coin insertion slot 205. The player can insert bills to be bet on the game into the slot machine 200 via the bill insertion slot 206. The player can insert the ID card 11 via the ID card insertion slot 207. The player can receive the receipt 12 via the issue slot 208 when the slot machine 200 determines the player wins the game.

The spin button 209, the BET selection buttons 210, the line selection buttons 211 and the issue button 213 are mounted on the cabinet 201 to be located below the liquid crystal display panel 204. When the player presses the spin button 209, a start signal is input into the slot machine 200 so that the slot machine 200 starts to variably display the symbols to execute the game. When the player presses the BET selection buttons 210 to select the number of coins to be bet on the game, a BET selection signal is input into the slot machine 200 so that the slot machine 200 set the number of bet coins. When the player presses the line selection buttons 211 to select one or more desired paylines among a plurality of paylines (not shown), a line selection signal is input into the slot machine 200 so that the slot machine 200 set the desired payline(s). When the player presses the issue button 213, an issue signal is input into the slot machine 200 so that the slot machine 200 issues the receipt 12.

As shown in FIG.6, the slot machine 200 further comprises a microcomputer 221, an I/O port 225, a random number generating circuit 226, a sampling circuit 227, a clock pulse generating circuit 228, a frequency dividing circuit 229, a communication control unit 230, a communication process unit 231, a switch input unit 232, a coin sensor 238, a bill sensor 239, a card reader 240, an issue device 241, a lamp driving circuit 242, a lamp 243, an LED driving circuit 244, an LED 245, an image control circuit 246, a sound control circuit 247 and a speaker 248.

The microcomputer 221 has a main CPU 222, a RAM 223 and a ROM 224. The main CPU 222 operates on programs stored in the ROM 224 and receives/sends various signals from/to other constructional elements via the I/O port 225, which controls the slot machine 200. The RAM 223 temporarily stores programs and/or data (e.g. random numbers, code numbers of the video reels, symbol numbers and the like) employed by the main CPU 222. The ROM 224 perpetually stores the programs and data (e.g. a winning determination table, a symbol determination table, a stop table, a dividend rate table and the like) to be employed by the main CPU 222.

The random number generating circuit 226 generates random numbers within a certain definite range according to an order of the main CPU 222. The sampling circuit 227 samples a certain random number among the generated random numbers according to an order of the main CPU 222, and then inputs the sampled random

number into the main CPU 222. The clock pulse generating circuit 228 generates a reference clock for allowing the main CPU 222 to operate. The frequency dividing circuit 229 divides the generated reference clock at a constant frequency, and then
5 inputs the divided reference clock into the main CPU 222.

The communication control unit 230 operates according to an order of the main CPU 222 to control a line connection and a line disconnection between the slot machine 200 and the gaming settlement machine 1. The communication process unit 231
10 operates according to an order of the communication control unit 230 to send the winning information IN1 via the network N1.

The switch input unit 232 has a start switch 233, a BET switch 234, a line switch 235 and an issue switch 237. The
15 start switch 233 inputs the start signal into the main CPU 222 when the spin button 209 is pressed. The BET switch 234 inputs the BET selection signal into the main CPU 222 when one or more the pressed BET selection buttons are pressed. The line switch 235 inputs the line selection signal into the main CPU
20 222 when one or more the line selection buttons 211 are pressed. The issue switch 237 inputs the issue signal into the main CPU 222 when the issue button 213 is pressed.

The coin sensor 238 detects a coin inserted into the coin insertion slot 205, and then inputs a coin detection signal
25 into the main CPU 222. The bill sensor 239 detects a bill inserted into the bill insertion slot 206, and then inputs a bill detection

signal into the main CPU 222. The card reader 240 reads the player ID stored on the ID card 11 which is inserted into the ID card insertion slot 207, and then inputs the read player ID into the main CPU 222. The issue device 241 issues the receipt 5 12 on which the winning information IN1 for informing a dividend amount to be paid out and the player ID for identifying a player who will obtain the dividend amount are printed as the barcode, when the issue signal is input from the issue switch 237 into the main CPU 222.

10 The lamp driving circuit 242 outputs to the lamp 243 a signal for lighting the lamp 243 and then blinks the lamp 243 during the game. The LED driving circuit 244 controls a blink of the LED 243. The LED 243 indicates the number of credits, the number of obtained coins and the like.

15 The image control circuit 246 controls image displays of the liquid crystal display panels 202, 203, 204 according to an order of the main CPU 222. As shown in FIG.7, the image control circuit 246 has an image control CPU 246a, a work RAM 246b, a program ROM 246c, an image ROM 246d, a video RAM 246e 20 and a VDP (Video Display Processor) 246f.

The image control CPU 246a determines an image to be displayed on the liquid crystal display panels 202, 203, 204 according to an image control program previously stored in the program ROM 246c, on the basis of a parameter set in the 25 microcomputer 221. The work RAM 246b temporarily stores data when the image control CPU 246a executes the image control program.

The program ROM 246c perpetually stores the image control program and various tables. The image ROM 246d perpetually stores dot data to be employed to form images. The video RAM 246e temporarily stores data when the VDP 246f forms images. The VDP 246f has a control RAM 246g and outputs the images determined by the image control CPU 246a to the liquid crystal display panels 202, 203, 204.

The sound control circuit 247 inputs a sound signal into the speaker 248 so that the speaker 248 outputs sounds (e.g. sounds for bringing lots of excitement to the game at appropriate time after starting the game).

(Behavior of gaming identification system)

As shown in FIG.8, when the slot machine 200 starts a main process, the slot machine 200 carries out a start reception process S1 and a sortition process S2 before a game start.

In the start reception process S1, the slot machine 200 receives a start operation for starting the game from a player according to a control of the main CPU 222. More specifically, the player inserts own ID card 11 into the ID card insertion slot 207. Then, the player inserts one or more coins into the coin insertion slot 205 or one or more bills into the bill insertion slot 206 to increase the number of credits, in order to rotate the video reels to display the symbols variably. Next, the player presses the BET selection buttons 210 to select the number of coins to be bet on the game. Futher, the player presses

the line selection buttons 211 to select one or more desired paylines among the plurality of paylines and then presses the spin button 209. The start operation allows a player ID stored in the ID card 11 and the start signal from the start switch 233 to be input into the main CPU 222. When the player presses the spin button 209 to input the start signal into the main CPU 222, the random number generating circuit 226 generates random numbers within the certain definite range according to the order of the main CPU 222.

10 In the sortition process S2, as shown in FIG.9, the slot machine 200 carries out a symbol determination process S13 to determine a symbol to be stopped on the selected payline by each video reel. More specifically, the sampling circuit 227 samples a certain random number among the generated random numbers by each video reel, according to the order of the main CPU 222, and then inputs the sampled random number into the main CPU 222. The main CPU 222 searches a code number associated with the sampled random number with reference to the symbol determination table, to obtain the associated code number. The main CPU 222 further searches a symbol associated with the obtained code number with reference to the stop table, to obtain the associated symbol to be stopped on the selected payline.

25 The slot machine 200 carries out a dividend rate determination process S14 when finishing the symbol determination process S13. In the dividend rate determination process S14, the main CPU 222 determines a dividend rate

associated with the obtained symbol combination with reference to the dividend rate table. Here, each dividend rate per coin associated with each symbol combination is registered in the dividend rate table.

5 The slot machine 200 carries out a variable display process S3 when finishing the dividend rate determination process S14. In the variable display process S3, the image control circuit 246 displays a game execution image including variable display images of the video reels on the liquid crystal display panel
10 204 according to the order of the main CPU 222. The video reels are abreast displayed on a center portion of the liquid crystal display panel 204. The paylines are linealy displayed on the center portion of the liquid crystal display panel 204. The symbols virtually mounted on each video reel are variably display
15 such that each symbol appears irregularly.

The slot machine 200 carries out a stop control process S4 when finishing the variable display process S3. In the stop control process S4, the image control circuit 246 stops the video reels so that the result of the sortition process S2 is
20 realized, according to the order of the main CPU 222.

The slot machine 200 determines whether or not the obtained symbol combination is a winning combination with reference to the winning determination table (S5). Here, winning combinations and non-winning combinations are registered in
25 the winning determination table. More specifically, the main CPU 222 determines whether or not the obtained symbol combination

is a winning combination by comparing code numbers of symbols forming the obtained symbol combination with code numbers of symbols forming each winning combination registered in the winning determination table. If the obtained symbol combination is a winning combination, the main process proceeds to S6. In contrast, if the obtained symbol combination is a non-winning combination, the main process is finished.

When the main process proceeds to S6, the slot machine 200 determines whether or not the issue button 213 is pressed.

More specifically, the main CPU 222 determines whether or not the issue signal from the issue switch 237 is input thereinto. If the issue button 213 is pressed, the main process proceeds to S7. In contrast, if the issue button 213 is not pressed, the main process proceeds to S9 and then is finished. When the main process proceeds to S9, the main CPU 222 adds the dividend amount to be paid out to the credits.

When the main process proceeds to S7, the issue device 241 issues the receipt 12 on which the winning information IN1 for informing a dividend amount to be paid out and the player ID for identifying the player who will obtain the dividend amount are printed as the barcode, and then ejects the receipt 12 from the issue slot 208, according to the order of the main CPU 222. Then, when the main process proceeds to S8, the communication control unit 230 operates according to the order of the main CPU 222 to send the winning information IN1 to the gaming settlement machine 1 via the network N1 by means of the

communication process unit 231, which finishes the main process.

As shown in FIG.10, the gaming settlement machine 1 carries out a main process in parallel with the main process of the slot machine 200. When the main process proceeds to S21, the main CPU 22 determines whether or not the communication process unit 27 receives the winning information IN1 from the slot machine 200. If the communication process unit 27 receives the winning information IN1, the main process proceeds to S22. If the communication process unit 27 does not receive the winning information IN1, the main process remains at S21.

When the main process proceeds to S22, the main CPU 22 determines whether or not the player inserts the ID card 11 into the card insertion slot 5. If the player inserts the ID card 11 into the card insertion slot 5, the main process proceeds to S23. If the player does not insert the ID card 11 into the card insertion slot 5, the main process remains at S 22.

When the main process proceeds to S23, the card reader 5a reads the player ID stored in the inserted ID card 11 according to the order of the main CPU 22, and then inputs the read player ID into the main CPU 22.

When the main process proceeds to S24, the main CPU 22 determines whether or not the player holds the receipt 12 over the barcode reader 13. If the player holds the receipt 12 over the barcode reader 13, the main process proceeds to S25. If the player does not hold the receipt 12 over the barcode reader 13, the main process remains at S24.

When the main process proceeds to S25, the barcode reader 13 reads the winning information IN1 and the player ID stored in the barcode printed on the receipt 12 and then inputs them into the main CPU 22.

5 When the main process proceeds to S26, the main CPU 22 determines whether or not the player ID read in S23 corresponds to the player ID read in S25. If the player ID read in S23 corresponds to the player ID read in S25, the main CPU 22 recognizes that the player who wins the game is identical with
10 the player who will obtain the dividend amount, and then the main process proceeds to S27. If the player ID read in S23 does not correspond to the player ID read in S25, the main CPU 22 recognizes that the player who wins the game is not identical with the player who will obtain the dividend amount, and then
15 the main process is finished.

When the main process proceeds to S27, the main CPU 22 executes a payout process. As shown in FIG.11, when the payout process proceeds to S31, the main CPU 22 determines whether or not a winning mode obtained by the player is the special
20 winning mode (hereinafter called taxation winning mode) which is subject to taxation, on the basis of the winning information IN1 read in S23. If the winning mode is the taxation winning mode, the payout process proceeds to S32. If the winning mode is not the taxation winning mode, the payout process proceeds
25 to S42. In the exemplary embodiment, the taxation winning mode is defined as a winning mode in which a player can obtain game

media(dividend amount) corresponding to a money amount equal to or more than a taxable money amount (e.g. 1200 U.S. dollars in a case where the gaming settlement machine 1 and the slot machine 200 are located at Las Vegas in Nevada). However, the definition of the taxation winning mode is not limited to the above definition.

When the payout process proceeds to S32, the liquid crystal display panel 8 displays a message that prompts the player to insert the passport 10 into the passport insertion slot 4, according to an order of the main CPU 22.

When the payout process proceeds to S33, the main CPU 22 determines whether or not the player inserts a page, on which a facial photograph and personal information are printed, of the passport 10 into the passport insertion slot 4. If the player inserts the page, the payout process proceeds to S34. If the player does not insert the page, the payout process remains at S33.

When the payout process proceeds to S34, the scanner 4a scans the facial photograph and the personal information according to the order of the main CPU 22, and then inputs them into the main CPU 22. Then, the main CPU 22 generates the player image data P2 on the basis of the scan data. It is preferred that the operator confirms whether or not the passport 10 is an authentic passport on the basis of a passport number which is printed on the passport 10 at a time of scanning the passport 10.

When the payout process proceeds to S35, the CCD camera 3 takes a face image of the player who stands so as to be opposed to the front side of the gaming settlement machine 1 according to the order of the main CPU 22, and then inputs the face image data into the main CPU 22. Then, the main CPU 22 generates the player image data P1 on the basis of the face image data.

When the payout process proceeds to S36, the communication control unit 26 sends the player image data P1, P2 to the gaming terminal machine 100 via the communication process unit 27 and the network N2, according to the order of the main CPU 22.

When the payout process proceeds to S37, the main CPU 22 determines whether or not the communication process unit 27 receives the payout order data IN2 from the gaming terminal machine 100. If the communication process unit 27 receives the payout order data IN2, the payout process proceeds to S38. If the communication process unit 27 does not receive the payout order data IN2, the payout process remains at S37.

When the payout process proceeds to S38, the main CPU 22 determines whether or not the payout order data IN2 includes the payout permission information. If the payout order data IN2 includes the payout permission information, the payout process proceeds to S39. If the payout order data IN2 does not include the payout permission information, the payout process proceeds to S43.

When the payout process proceeds to S39, the main CPU 22 calculates tax charge to be paid according to the obtained

dividend amount. More specifically, the main CPU 22 multiplies a predetermined tax rate by the obtained dividend amount to obtain the tax charge. The main CPU 22 further subtracts the tax charge from the obtained dividend amount to obtain a tax excluded dividend amount.

When the payout process proceeds to S40, the liquid crystal display panel 8 displays a tax payment confirmation screen 40 according to an order of the main CPU 22 (see FIG.13). The tax payment confirmation screen 40 has a display field 40a and a sign entry field 40b. The liquid crystal display panel 8 displays a message for confirming the player's willingness to pay the tax charge by using the gaming settlement machine 1, on the display field 40a. In addition, the liquid crystal display panel 8 displays the dividend amount (e.g. 2000 dollars), the tax charge (e.g. 600 dollars) and the tax excluded dividend amount (e.g. 1400 dollars) on the display field 40a.

The player confirms the dividend amount, the tax charge and the tax excluded dividend amount with reference to the tax payment confirmation screen 40. If the player is willing to pay the tax charge by using the gaming settlement machine 1, the player enters his/her sign in a sign block of the sign entry field 40b with the electronic pen and then touches an "OK" block of the sign entry field 40b with his/her finger. When the touch panel 9 detects the player's finger, the image generating portion 9a generates a sign image data of the entered player's sign. Then, the communication process unit 27 sends the sign image

data to the gaming terminal machine 100 according to an order of the communication control unit 26. Instead of entering the player's sign, the player may enter a finger mark of his/her first finger or second finger.

5 When the payout process proceeds to S41, the main CPU 22 determines whether or not the player has entered his/her sign. If the player has entered his/her sign, the payout process proceeds to S42. If the player has not entered his/her sign, the payout process remains at S41.

10 When the payout process proceeds to S42, the main CPU 22 carries out a payout of the tax excluded dividend amount. More specifically, the coin hopper driving circuit 28a drives the coin hopper 28b to eject one or more coins corresponding to the tax excluded dividend amount from the coin ejection slot
15 5 according to an order of the main CPU22, or the bill ejection device driving circuit 29a drives the bill ejection device 29b to eject one or more bills corresponding to the tax excluded dividend amount from the bill ejection slot 6 according to an order of the main CPU 22.

20 When the payout process proceeds to S43, the operator is called to carry out the manual tax payment process (see FIG.14). FIG.14 shows the manual tax payment process in Nevada.

 When the manual tax payment process proceeds to S61, the operator identifies the player by using player's
25 photo-identification document (e.g. a driver's license or a passport) issued by a public institution. When the manual tax

payment process proceeds to S62, the operator receives the photo-identification document to create necessary papers with reference to the photo-identification document. At the time of creating the necessary papers, the operator enters a name, an address, a birth date, SSN (social security number) and the like registered in the photo-identification document into the gaming terminal machine 100.

When the manual tax payment process proceeds to S63, the operator determines whether or not the player has filed his/her income tax return in the U.S.A. If the player has filed it, the manual tax payment process proceeds to S65. If the player has not filed it, the manual tax payment process proceeds to S64. When the manual tax payment process proceeds to S64, the operator further determines whether or not the player is a citizen in one of counties that have concluded a taxation arrangement with the U.S.A. If the player is the citizen, the manual tax payment process proceeds to S68. If the player is not the citizen, the manual tax payment process proceeds to S67. When the manual tax payment process proceeds to S65, the player selects either a now-payment or a post-payment. When the manual tax payment process proceeds to S66, the operator determines whether or not the player selects the now-payment. If the player selects the now-payment, the manual tax payment process proceeds to S68. If the player selects the post-payment, the manual tax payment process proceeds to S67. When the manual payment process proceeds to S67, the operator pays out the dividend

amount to the player. When the manual payment process proceeds to S68, the operator pays out the tax excluded dividend amount to the player.

As shown in FIG.12, the gaming terminal machine 100 carries out a main process in parallel with the main process of the gaming settlement machine 1. When the main process proceeds to S51, the CPU 101 determines whether or not the player image data P1, P2 are received from the gaming settlement machine 1. If the player image data P1, P2 are received, the main process proceeds to S52. If the player image data P1, P2 are not received, the main process remains at S51.

When the main process proceeds to S52, the image control unit 106 displays on the display 107 an imaged player face extracted from the player image data P1, a scanned player face extracted from the player image data P2 and scanned personal information extracted from the player image data P2 according to the order of the CPU 101.

When the main process proceeds to S53, the CPU 101 determines whether or not the operator enters the identifiable information or the unidentifiable information into the gaming terminal machine 100. More specifically, the operator confirms the player's identification by comparing the imaged player face displayed on the display 107 with the scanned player face displayed on the display 107. Then, the operator confirms player's name and player's address by using the scanned personal information. Additionally, the operator may confirm the

entered player's sign by using the sign image data sent from the gaming settlement machine 1 and then displayed on the display 107. If the operator confirms the player's identification, the operator operates the operation unit 108 to enter the identifiable information into the gaming terminal machine 100. 5 If the operator does not confirm the player's identification, the operator operates the operation unit 108 to enter the unidentifiable information into the gaming terminal machine 100. In S53, if the operator operates the operation unit 108, 10 the main process proceeds to S54. If the operator does not operate the operation unit 108, the main process remains at S53.

When the main process proceeds to S54, if the CPU 101 receives the identifiable information, the CPU 101 generates the payout order data IN2 including the payout permission 15 information on the basis of the identifiable information. In contrast, if the CPU 101 receives the unidentifiable information, the CPU 101 generates the payout order data IN2 including the payout prohibition information on the basis of the 20 unidentifiable information.

When the main process proceeds to S55, the communication control unit 104 sends the payout order data IN2 to the gaming settlement machine 1 via the communication process unit 105 and the network N2, and then the main process is finished.

25

(Advantageous characteristics of gaming identification system)

In the case where the player obtains the taxation winning mode in the slot machine 200, the player image data P1, P2 are generated in the gaming settlement machine 1, according to the face image data generated by taking the player face image by means of the CCD camera 3 and the scan data generated by scanning the facial photograph printed on the passport 10 by means of the scanner 4a. Then, the player image data P1, P2 are sent to the gaming terminal machine 100. The gaming terminal machine 100 displays the imaged player face and the scanned player face on the display 107 according to the received player image data P1, P2. If the operator confirms the player's identification, the gaming terminal machine 100 sends the payout order data IN2 to the gaming settlement machine 1. If the payout order data IN2 includes the payout permission information, the gaming settlement machine 1 pays out the tax excluded dividend amount to the player. Therefore, the identification time can be shortened to reduce the waiting time for the player and the electrical power consumption of the slot machine 200, because the operator needs not to go to an installation site where the gaming settlement machine 1 or the slot machine 200 is installed.

The operator can confirm the personal information of the player by using the scanned personal information. Therefore, the identification time can be shortened to reduce the waiting time for the player and the electrical power consumption of the slot machine 200, because the operator needs not to receive the photo-identification document to create the necessary

papers manually.

The operator confirms the player's identification by means of the face image data generated by taking the player face image by means of the CCD camera 3 and the scan data generated by scanning the facial photograph printed on the passport 10 by means of the scanner 4a. Then, when the operator confirms the player's identification, the gaming terminal machine 100 generates the payout order data IN2 including the identifiable information or the unidentifiable information. Therefore, the gaming settlement machine 1 can safely pay out the tax excluded dividend amount to the player.

In the case where the player obtains the taxation winning mode in the slot machine 200, the gaming settlement machine 1 confirms coincidence between the player ID stored in the ID card 11 and the player ID stored in the receipt 12. Therefore, the gaming settlement machine 1 can prevent a malicious third party from impersonating the player, which safely pays out the tax excluded dividend amount to the player.

(First modified example of exemplary embodiment of gaming identification system)

As shown in FIG.15, a gaming identification system 400 differs from the gaming identification system 300 in that a gaming server 500 and a network N3 are mounted between the gaming settlement machine 1 and a plurality of slot machines 200. In the gaming identification system 400, coins bet by players are

stocked. When a player wins the game and obtains the special winning mode, one or more the stocked coins are paid out to the player. This game is called a progressive jackpot type game.

5 The gaming identification system 400 comprises the gaming settlement machine 1, the gaming terminal machine 100, the plurality of slot machines 200, the gaming server 500 and the networks N1, N2, N3. The gaming settlement machine 1 is connected to the gaming server 500 via the network N3 to
10 communicate with the gaming server 500. The gaming settlement machine 1 is also connected to the gaming terminal machine 100 via the network N2 to communicate with the gaming terminal machine 100. The slot machines 200 are connected to the gaming server 500 via the network N1 to communicate with the gaming server
15 500. The networks N1, N2, N3 are LAN (local area network), Internet or the like.

The gaming server 500 comprises a CPU 501, a ROM 502, a RAM 503, a communication control unit 504, a communication process unit 505 and a HDD 506. The CPU 501 operates on programs
20 stored in the ROM 502 to control the gaming server 500. The ROM 502 perpetually stores the programs and data to be employed by the CPU 501. The RAM 503 temporarily stores programs and/or data employed by the CPU 501. The communication control unit 504 operates according to an order of the CPU 501 to control
25 a line connection and a line disconnection between the gaming terminal machine 100 and the slot machines 200. The

communication process unit 505 operates according to an order of the communication control unit 504 to receive/send data from/to the gaming terminal machine 100 or the slot machines 200 via the networks N1, N3. The HDD 506 stores database regarding the number of stocked coins.

When a player bets one or more coins on the game in each slot machine 200, the slot machine 200 sends coin betting information N10 to the gaming server 500 via the network N1. If the gaming server 500 receives the coin betting information from the slot machine 200, the CPU 501 reads the database from the HDD 506 and then lays out it on the RAM 503. Then, the CPU 501 adds the number of bet coins to the number of stocked coins with reference to the coin betting information N10. Next, the CPU 501 determines the slot machine(s) 200 which will obtain the special winning mode, according to a certain condition.

When a winning mode obtained by the player is the special winning mode in the slot machine 200, the communication control unit 504 operates according to the order of the CPU 501 to send issue order information IN11 for causing the slot machine 200 to issue the receipt 12, to the slot machine 200 via the network N1. If the slot machine 200 receives the issue order information IN11, the issue device 241 issues the receipt 12 on which the winning information IN1 and the player ID are printed as the barcode according to the order of the main CPU 222, and then ejects the receipt 12 from the issue slot 208. Then, the communication control unit 230 operates according to the order

of the main CPU 222 to send the winning information IN1 to the gaming server 500 via the network N1. If the gaming server 500 receives the winning information IN1, the communication control unit 504 operates according to the order of the CPU 501 to send the winning information IN1 to the gaming settlement machine 1 via the network N3.

In the case where the plurality of slot machines 200 are connected to the gaming server 500 and the gaming server 500 determines the slot machine 200 which will obtain the special winning mode, even if the winning mode obtained by the player is the special winning mode, the identification time can be shortened to reduce the waiting time for the player and the electrical power consumption of the slot machine 200, because the operator needs not to go to an installation site where the gaming settlement machine 1 or the slot machine 200 is installed.

Futher, the operator can confirm the personal information of the player by using the scanned personal information. Therefore, the identification time can be shortened to reduce the waiting time for the player and the electrical power consumption of the slot machine 200, because the operator needs not to receive the photo-identification document to create the necessary papers manually.

(Second modified example of exemplary embodiment of gaming identification system)

As shown in FIG.17, a gaming identification system 600

differs from the gaming identification system 300 in that the gaming settlement machine 1 and the slot machine 200 are installed in a game arcade 610, the gaming terminal machine 100 is installed in a monitoring center 620 that is away from the game arcade 610, the gaming settlement machine 1 is connected to Internet 630 via a router 611 and the gaming terminal machine 100 is connected to Internet 630 via a router 612.

In the gaming identification system 600, an operator of the monitoring center 620 instead of the operator of the game arcade 610 can confirm the player's identification and then order the gaming settlement machine 1 to pay out the tax excluded dividend amount.

(Other modified example of exemplary embodiment of gaming identification system)

The CCD camera 3 may further be mounted in the slot machine 200. The slot machine 200 can take the player's face image by using the CCD camera 3 and then send the face image data to the gaming terminal machine 100. Therefore, the identification time can be shortened to reduce the waiting time for the player and the electrical power consumption of the slot machine 200 because the player needs not to be imaged in the gaming settlement machine 1.

The slot machine 200 may issue the receipt 12 on which the winning information IN1 and the player ID are printed as magnetic information by means of the issue device 241. At this

time, the gaming settlement machine 1 reads the winning information IN1 and the player ID by means of a magnetic reader, instead of the barcode reader 13.

5 The gaming settlement machine 1 may scan the facial photograph and the personal information preinted on a photo-identification document (e.g. a driver's license) issued by a public institution, insead of the passport 10, by means of the scanner 4a.

10 The plurality of slot machines 200 may directly connect to the gaming settlement machine 1 via a network. Each slot machine 200 has the following two connection styles: (1) the slot machine 200 is independent from the other slot machines 200; and (2) the slot machine 200 is connected to the other slot machines 200.

15 In the exemplary embodiment, the slot machine 200 is cited as a gaming machine. However, the gaming machine is not limited to the slot machine 200, it may be a roulette gaming machine, a card gaming machine or the like.

20 Instead of the personal confirmation in the gaming terminal machine 100, the gaming settlement machine 1 may confirm the player's identification automatically. More specifically, the CPU 22 automatically compares the imaged player face with the scanned player face according to an image analysis program stored in the ROM 24. If the CPU 22 confirms the player's
25 identification, the CPU 22 generates the payout permission information. If the CPU 22 does not confirm the player's

identification, the CPU 101 generates the payout prohibition information. At this time, the main process of the gaming terminal machine 100 is not required.

The reference numerals in the following claims do not in any way limit the scope of the respective claims.

Throughout this specification and the claims which follow, unless the context requires otherwise, the word "comprise", and variations such as "comprises" and "comprising", will be understood to imply the inclusion of a stated integer or step or group of integers or steps but not the exclusion of any other integer or step or group of integers or steps.

The reference to any prior art in this specification is not, and should not be taken as, an acknowledgement or any form of suggestion that that prior art forms part of the common general knowledge in Australia.

THE CLAIMS DEFINING THE INVENTION ARE AS FOLLOWS:

1. A gaming settlement machine (1) comprising:
 - a payout means (28b, 29b) configured to execute a payout according to a winning mode;
 - an image data generating means (22) configured to generate a player image data for identifying a player who is associated with the payout;
 - a sending control means (27) configured to send the player image data to an outside terminal machine (100);
 - a receiving means (27) configured to receive from the outside terminal machine (100) a payout order data for ordering whether or not the payout means (28a, 29b) is permitted to execute the payout to the player; and
 - a payout control means (22) configured to allow the payout means (28b, 29b) to execute the payout on the basis of the payout order data.

2. The gaming settlement machine (1) according to claim 1, further comprising an image taking means (3) configured to take a player's face image, wherein the image data generating means (22) generates the player image data by means of data of the player's face image taken by the image taking means (3).

3. The gaming settlement machine (1) according to claim 1 or 2, further comprising an image read means (4a) configured

to read a player's facial photograph from an identification document, wherein the image data generating means (22) generates the player image data by means of data of the player's facial photograph read by the image read means (4a).

5

4. The gaming settlement machine (1) according to claim 1, wherein the payout control means (22) allows the payout means (28b, 29b) to pay out a tax excluded dividend amount in a case where a dividend amount to be paid out to the player is subject to taxation.

10

5. A gaming terminal machine (100) comprising:

a display means (107) configured to display an image;

a display control means (106) configured to allow the display

15

means (107) to display a player's image by means of a player image data for identifying a player who is associated with a payout, which is sent from a gaming settlement machine (1) configured to execute the payout according to a winning mode;

20

a payout order data generating means (101) configured to generate a payout order data for ordering whether or not the gaming settlement machine (1) is permitted to execute the payout to a player who is identified on the basis of the displayed player's image; and

25

a sending control means (105) configured to send the payout order data to the gaming settlement machine (1).

6. The gaming terminal machine (100) according to claim 5, further comprising an operation means (108) configured to input identifiable information for showing that the player is identified on the basis of the displayed player's image, wherein the payout order data generating means (101) generates the payout order data in a case where the identifiable information is input by the operation means.

7. A gaming identification system (300, 400, 600) comprising:

a gaming settlement machine (1); and

a gaming terminal machine (100) connected to the gaming settlement machine (1),

wherein the gaming settlement machine (1) comprises:

a payout means (28b, 29b) configured to execute a payout according to a winning mode;

an image data generating means (22) configured to generate a player image data for identifying a player who is associated with the payout;

a sending control means (27) configured to send the player image data to the gaming terminal machine (100); and

a receiving means (27) configured to receive from the gaming terminal machine (100) a payout order data for ordering whether or not the payout means (28b, 29b) is permitted to execute the payout to the player who is identified; and

a payout control means (22) configured to allow the

payout means (28b, 29b) to execute the payout on the basis of the payout order data,

wherein the gaming terminal machine (100) comprises:

a display means (107) configured to display an image;

5 a display control means (106) configured to allow the display means (107) to display a player's image by means of the player image data sent from the gaming settlement machine (1);

10 a payout order data generating means (101) configured to generate the payout order data on the basis of the displayed player's image; and

a sending control means (105) configured to send the payout order data to the gaming settlement machine (1).

15 8. The gaming identification system (300, 400, 600) according to claim 7, wherein the gaming settlement machine (1) further comprises an image taking means (3) configured to take a player's face image, and the image data generating means (22) generates the player image data by means of data of the
20 player's face image taken by the image taking means (3).

9. The gaming identification system (300, 400, 600) according to claim 7 or 8, wherein the gaming settlement machine (1) further comprises an image read means (4a) configured to
25 read a player's facial photograph from an identification document, and the image data generating means (22) generates

the player image data by means of data of the player's facial photograph read by the image read means (4a).

10. The gaming identification system (300, 400, 600) according to claim 7, wherein the payout control means (22) allows the payout means (28b, 29b) to pay out a tax excluded dividend amount in a case where a dividend amount to be paid out to the player is subject to taxation.

10 11. The gaming identification system (300, 400, 600) according to claim 7 or 8, wherein the gaming terminal machine (100) further comprises an operation means (108) configured to input identifiable information for showing that the player is identified on the basis of the displayed player's image, 15 and the payout order data generating means (101) generates the payout order data in a case where the identifiable information is input by the operation means (108).

20 12. The gaming identification system (300, 400, 600) according to claim 9, wherein the gaming terminal machine (100) further comprises an operation means (108) configured to input identifiable information for showing that the player is identified on the basis of the displayed player's image, and

2006200831 27 Feb 2006

the payout order data generating means (101) generates the payout order data in a case where the identifiable information is input by the operation means (108).

DATED this TWENTYSEVENTH day of FEBRUARY 2006

Aruze Corp.

by DAVIES COLLISON CAVE
Patent Attorneys for the applicant(s)

FIG. 1

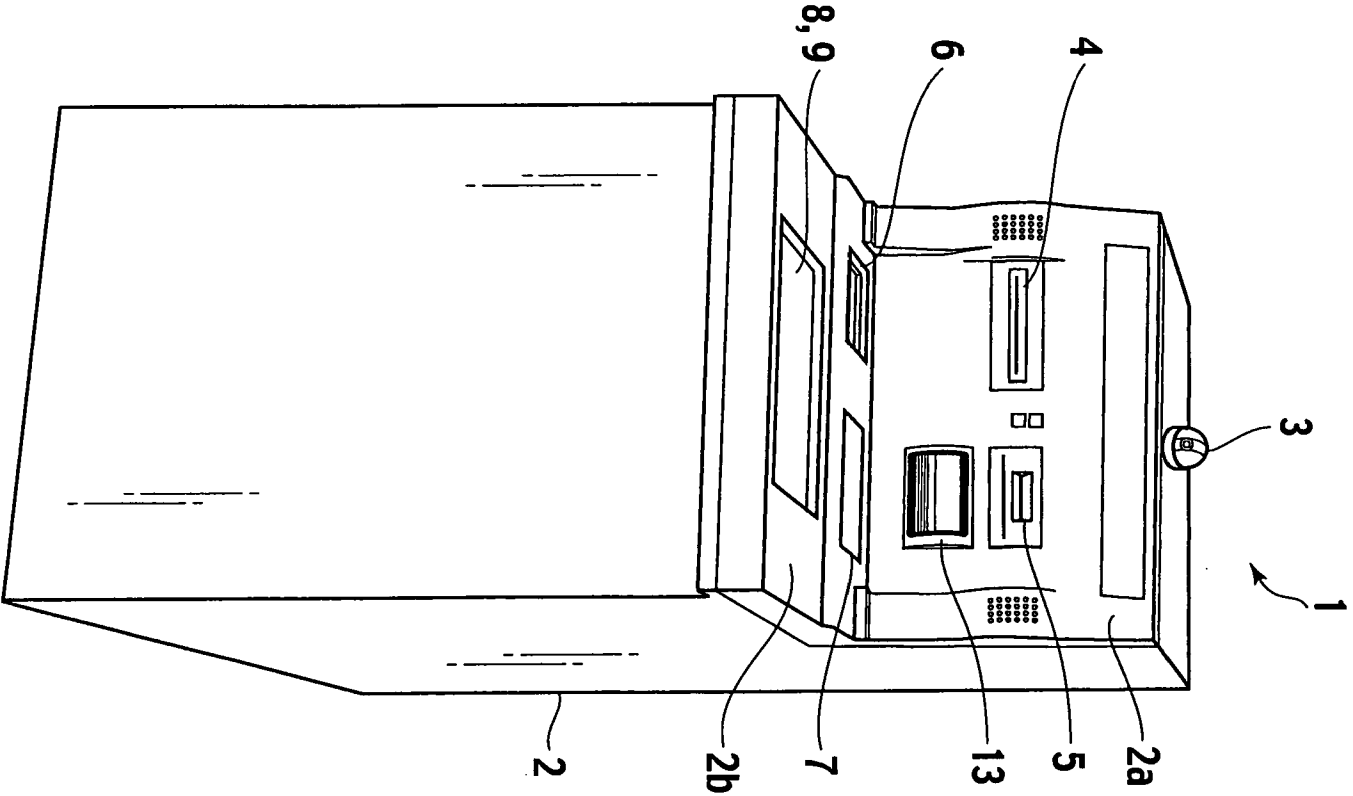

FIG. 2

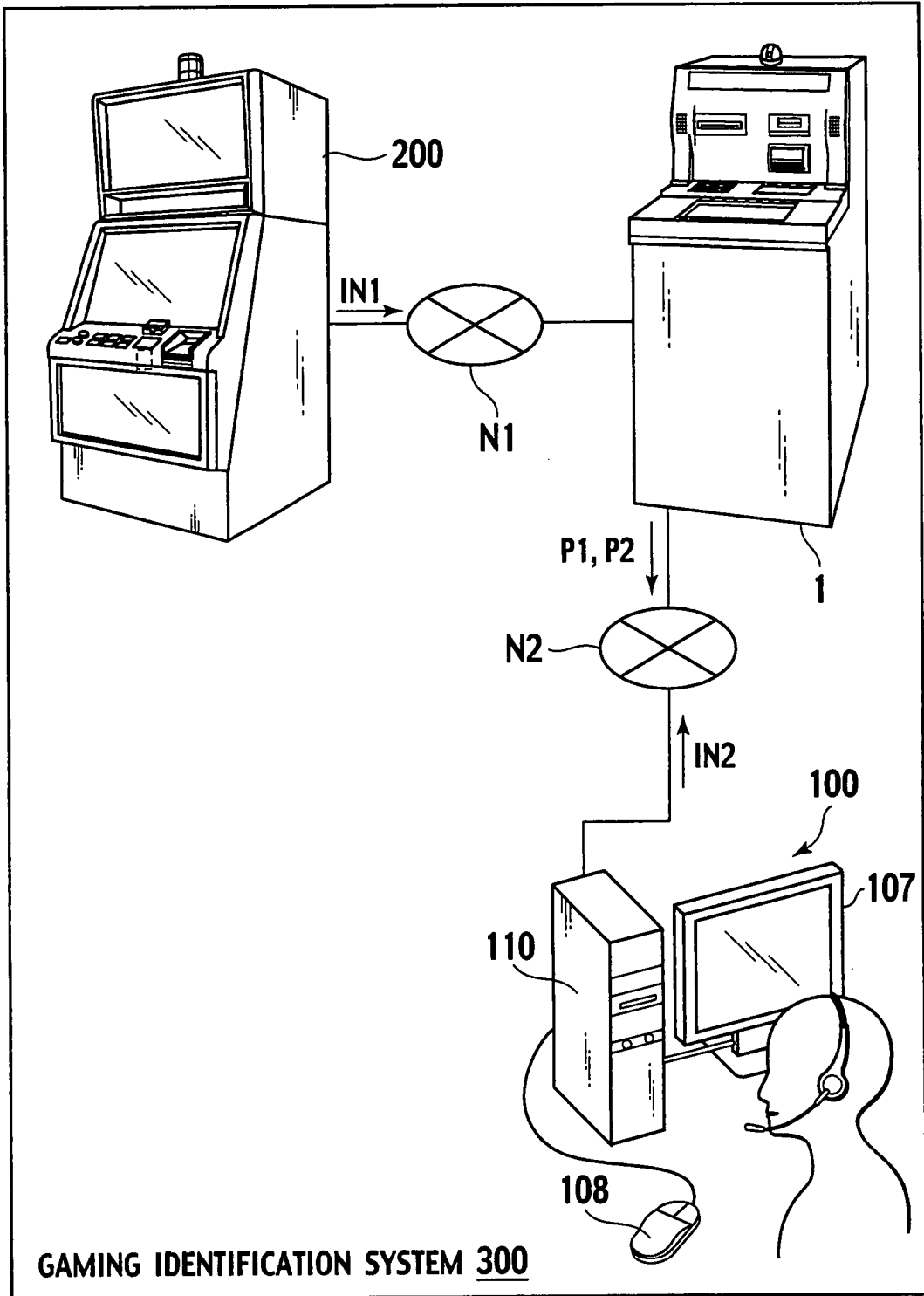

FIG. 3

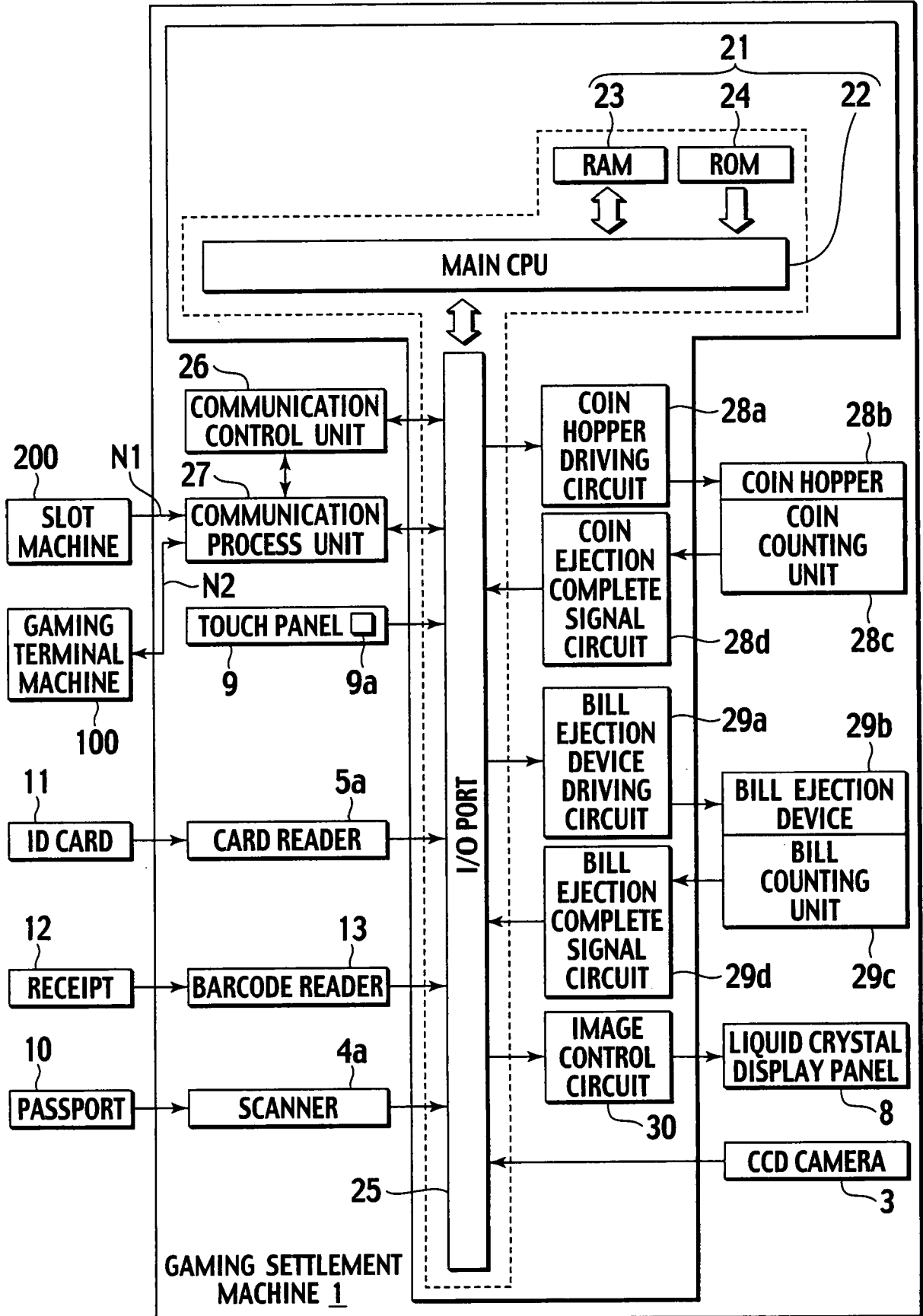

FIG. 4

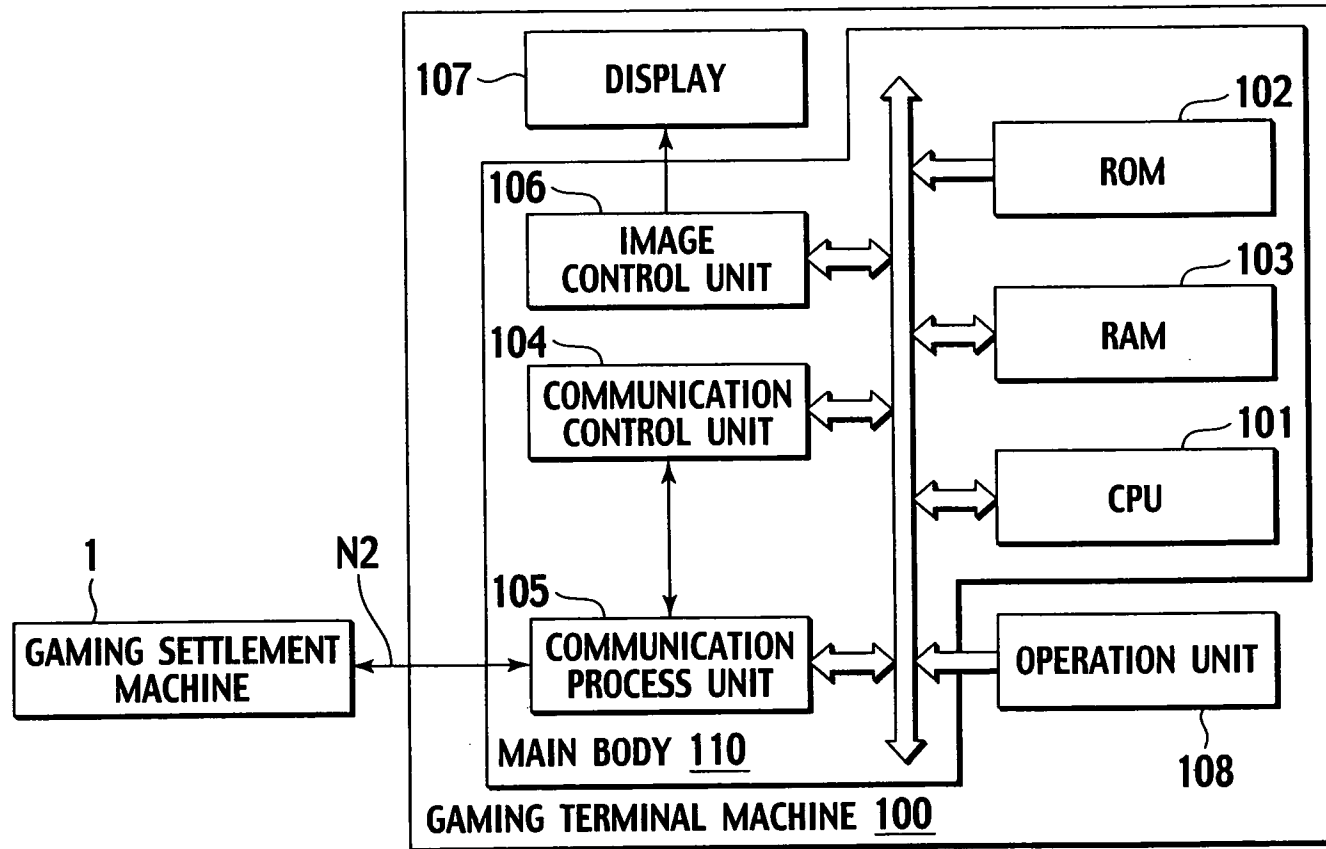
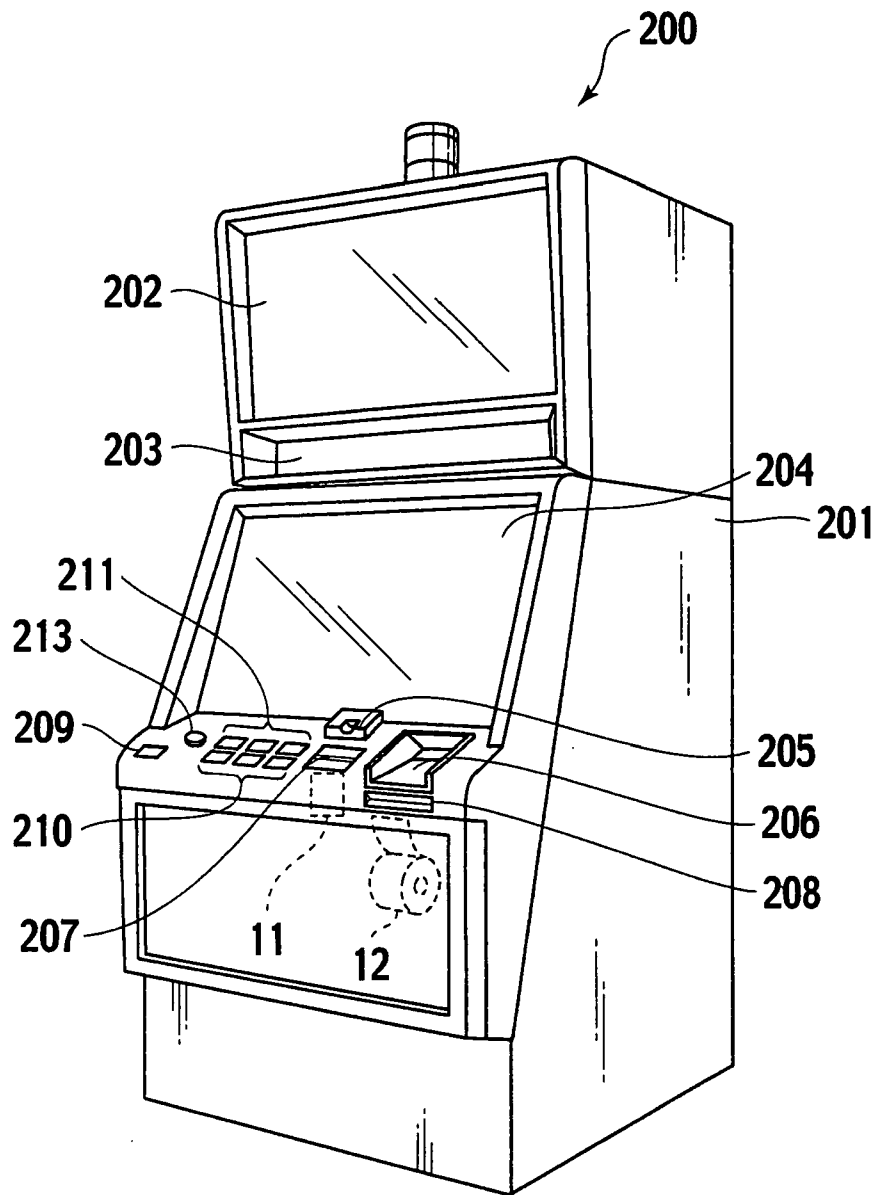

FIG. 5



6/16
FIG. 6

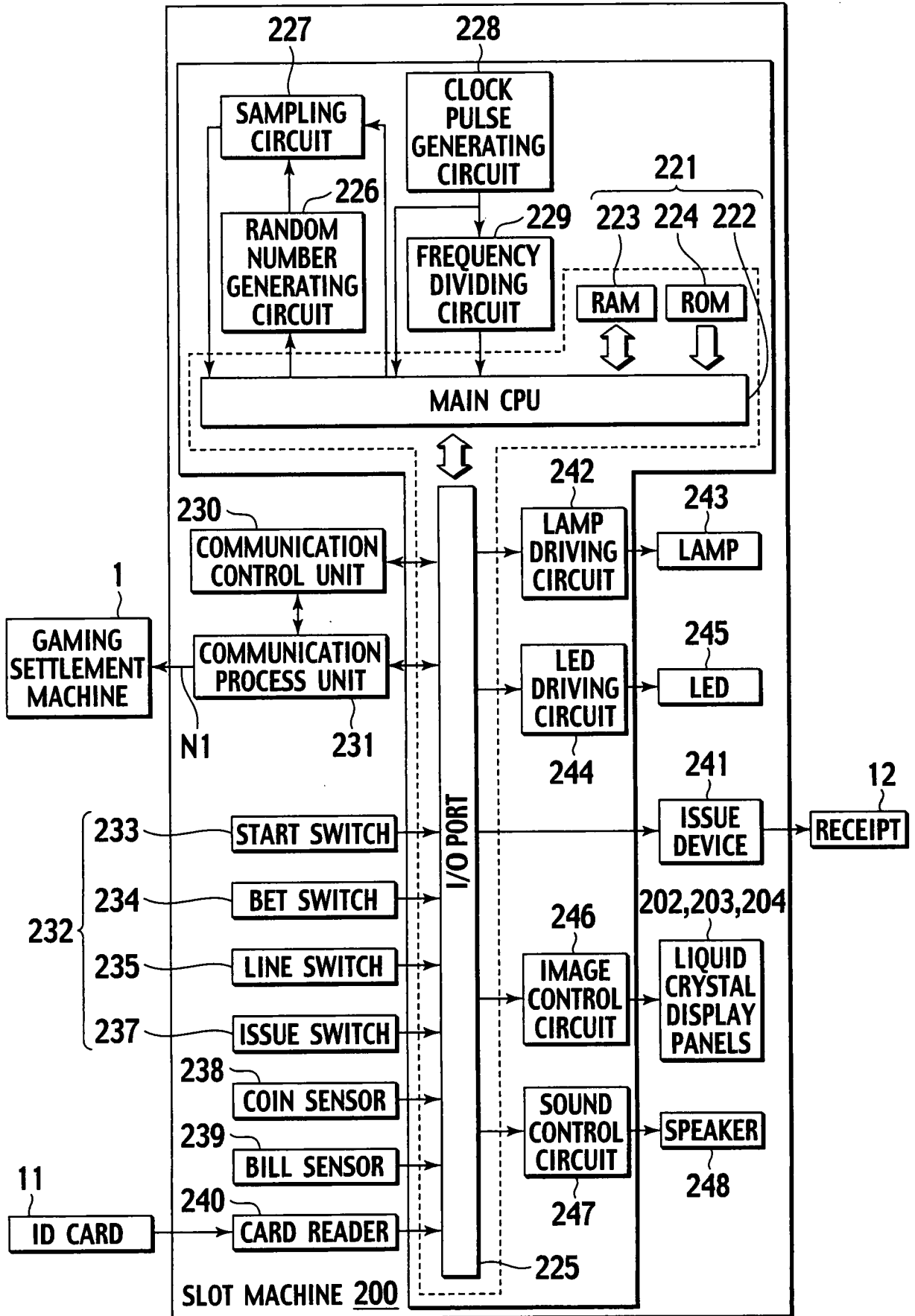

FIG. 7

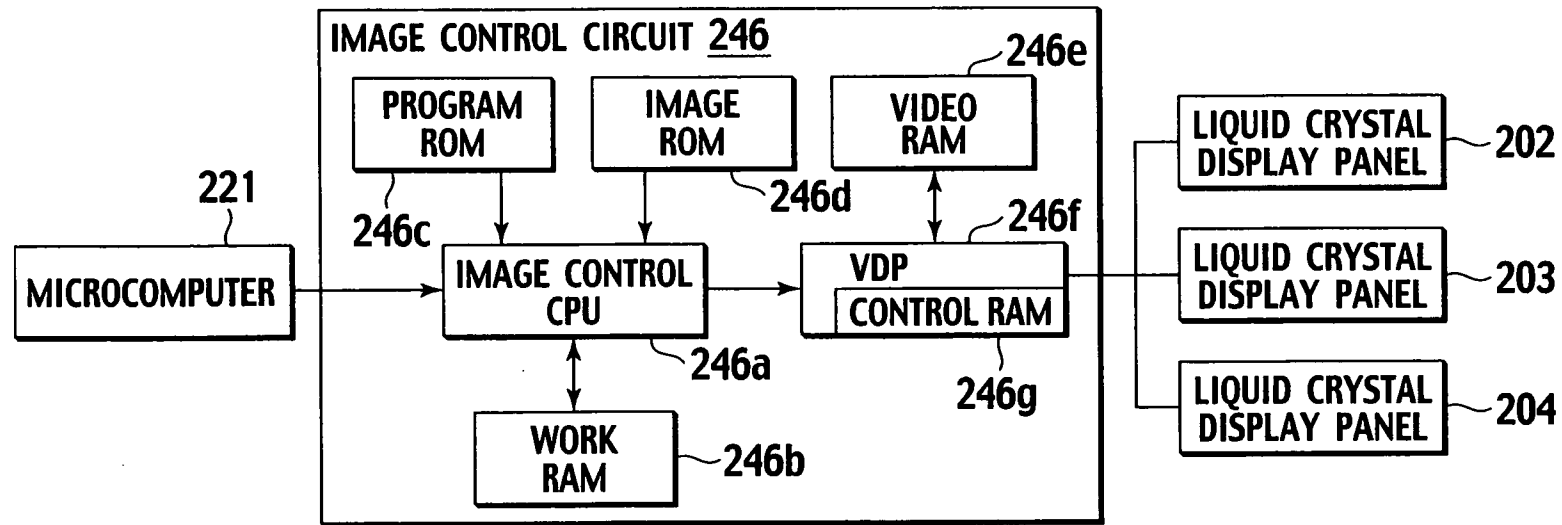

FIG. 8

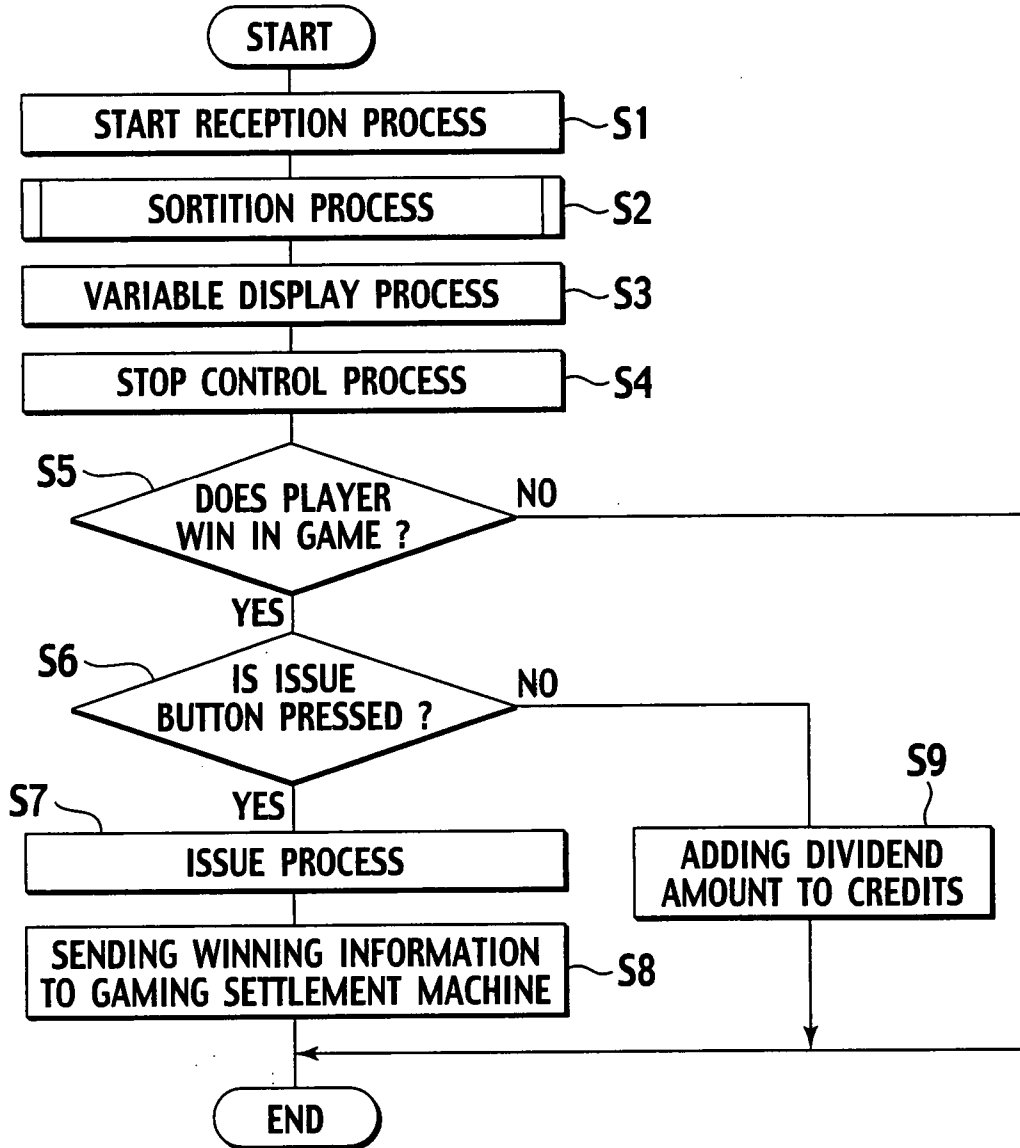

FIG. 9

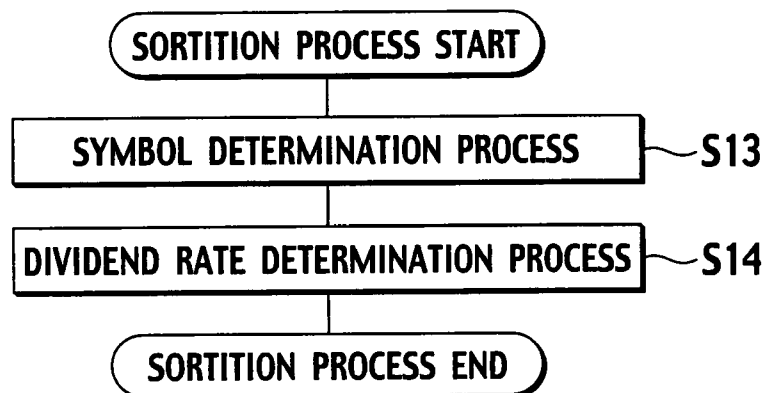

FIG. 10

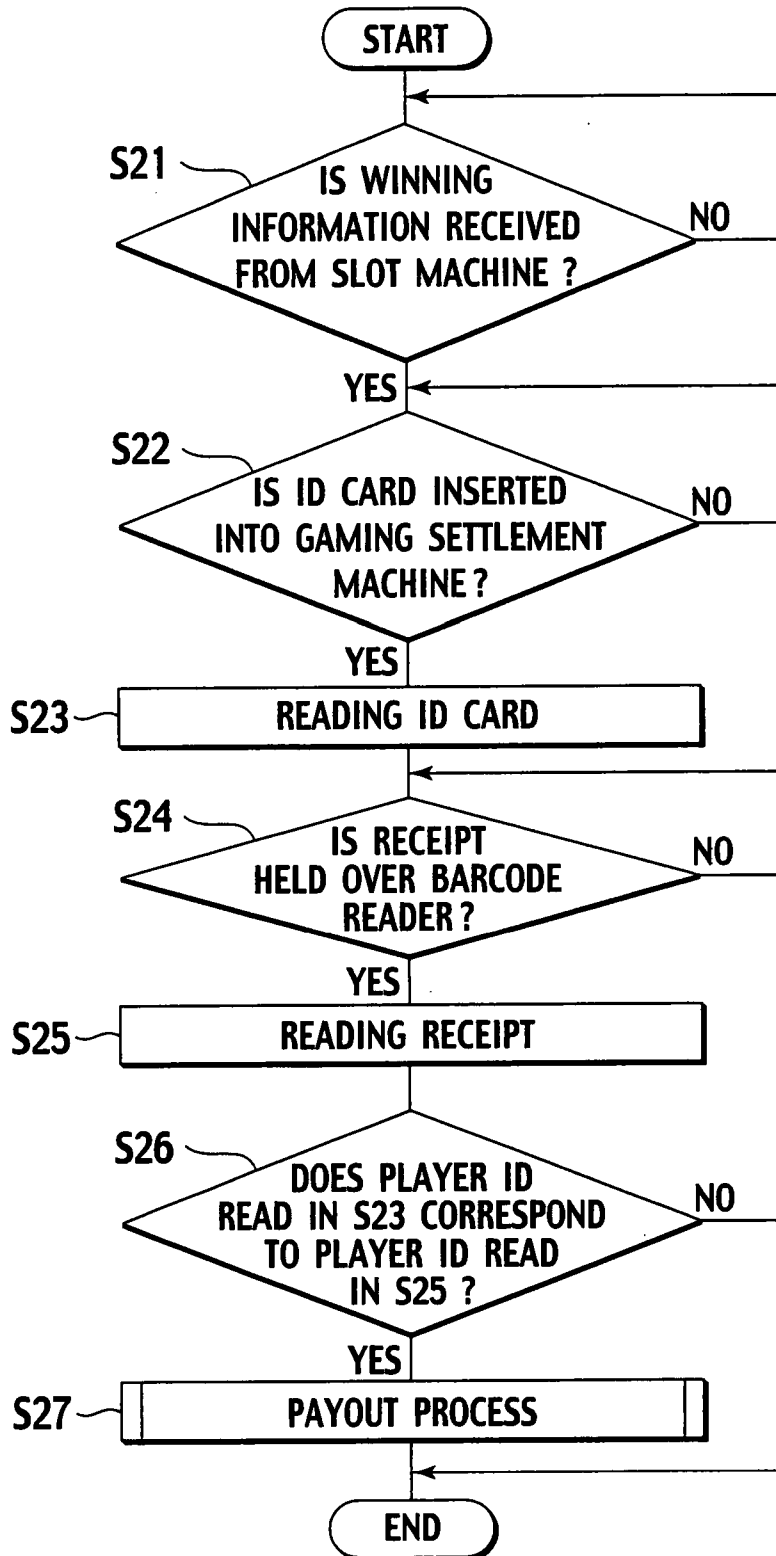

FIG. 11

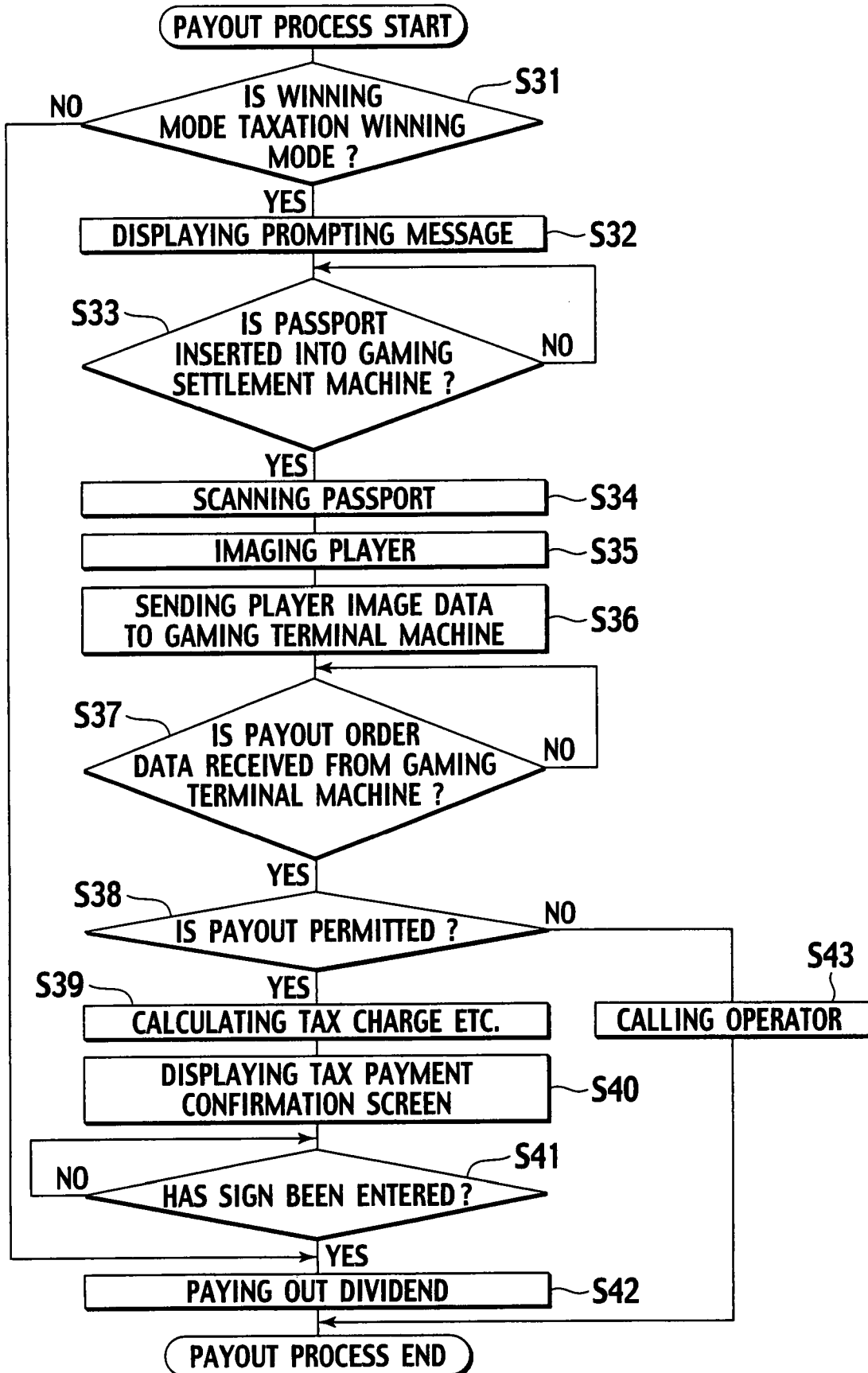

FIG. 12

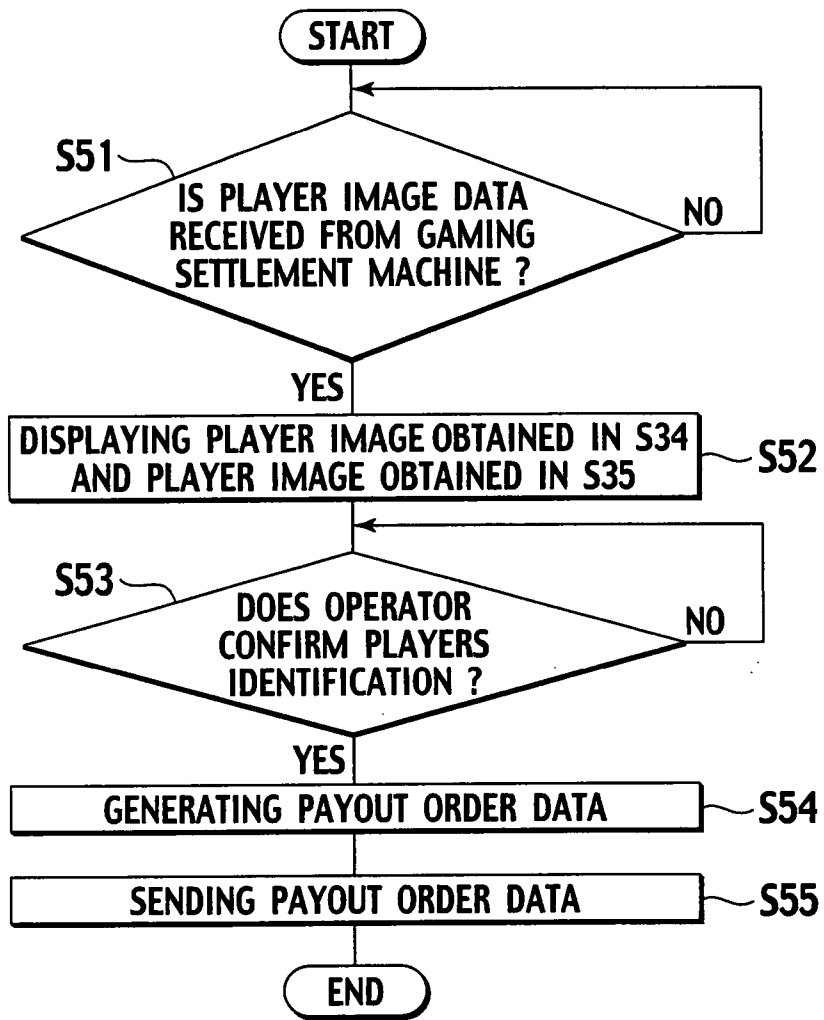

FIG. 13

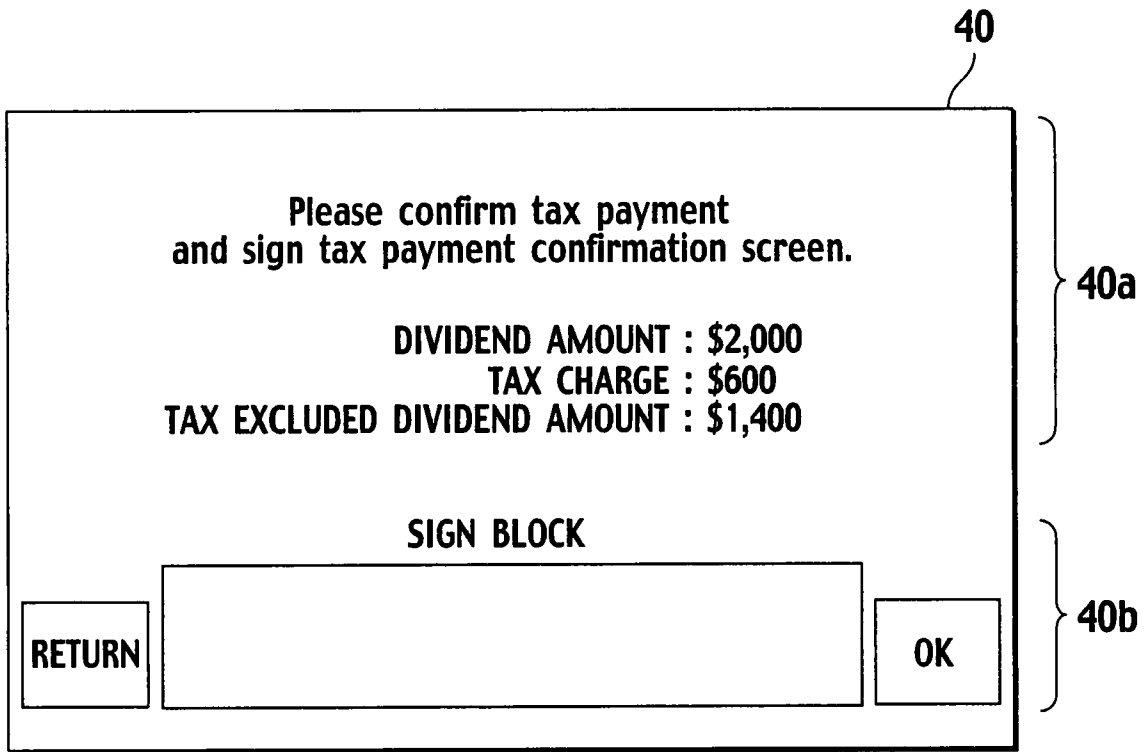

FIG. 14

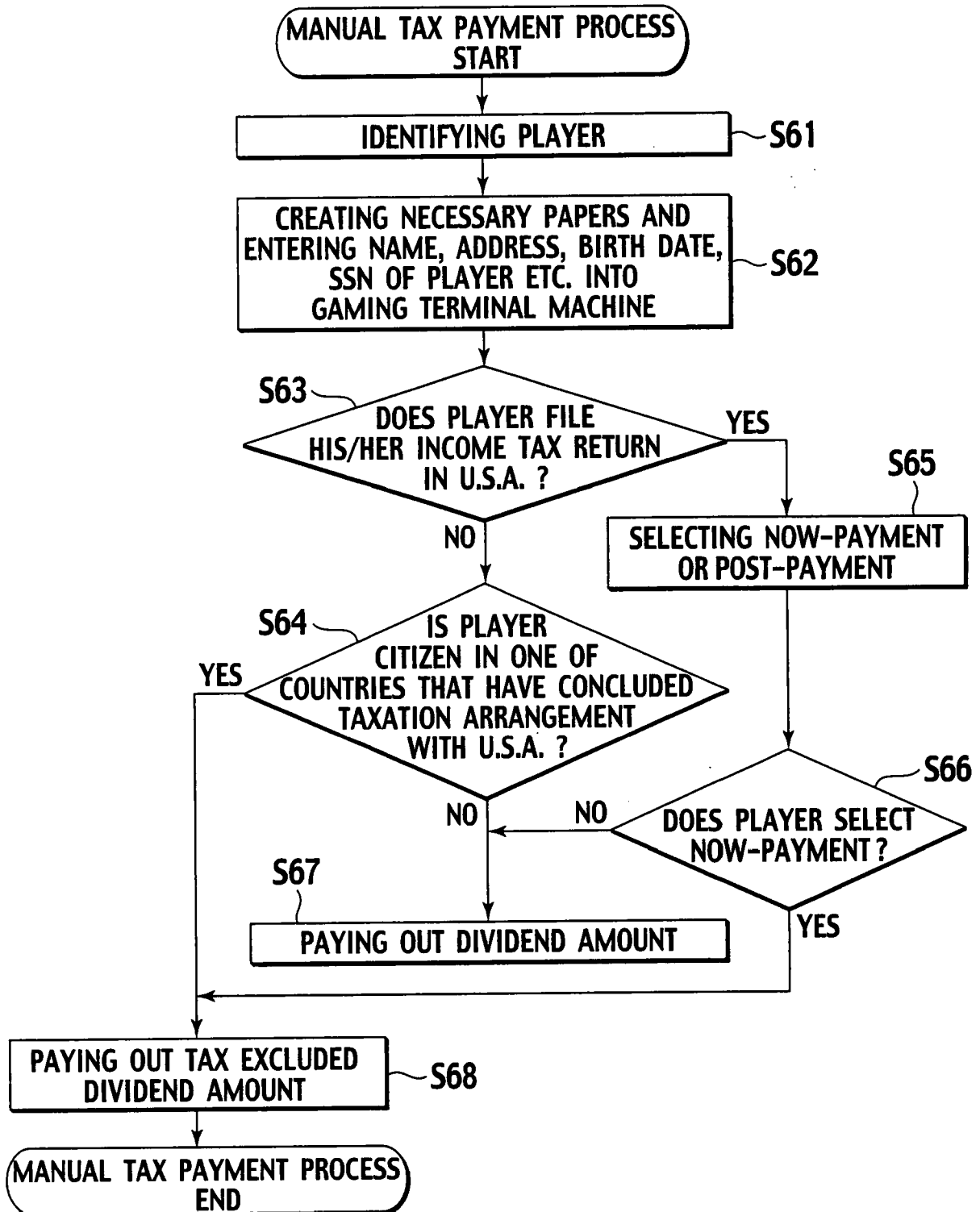

FIG. 15

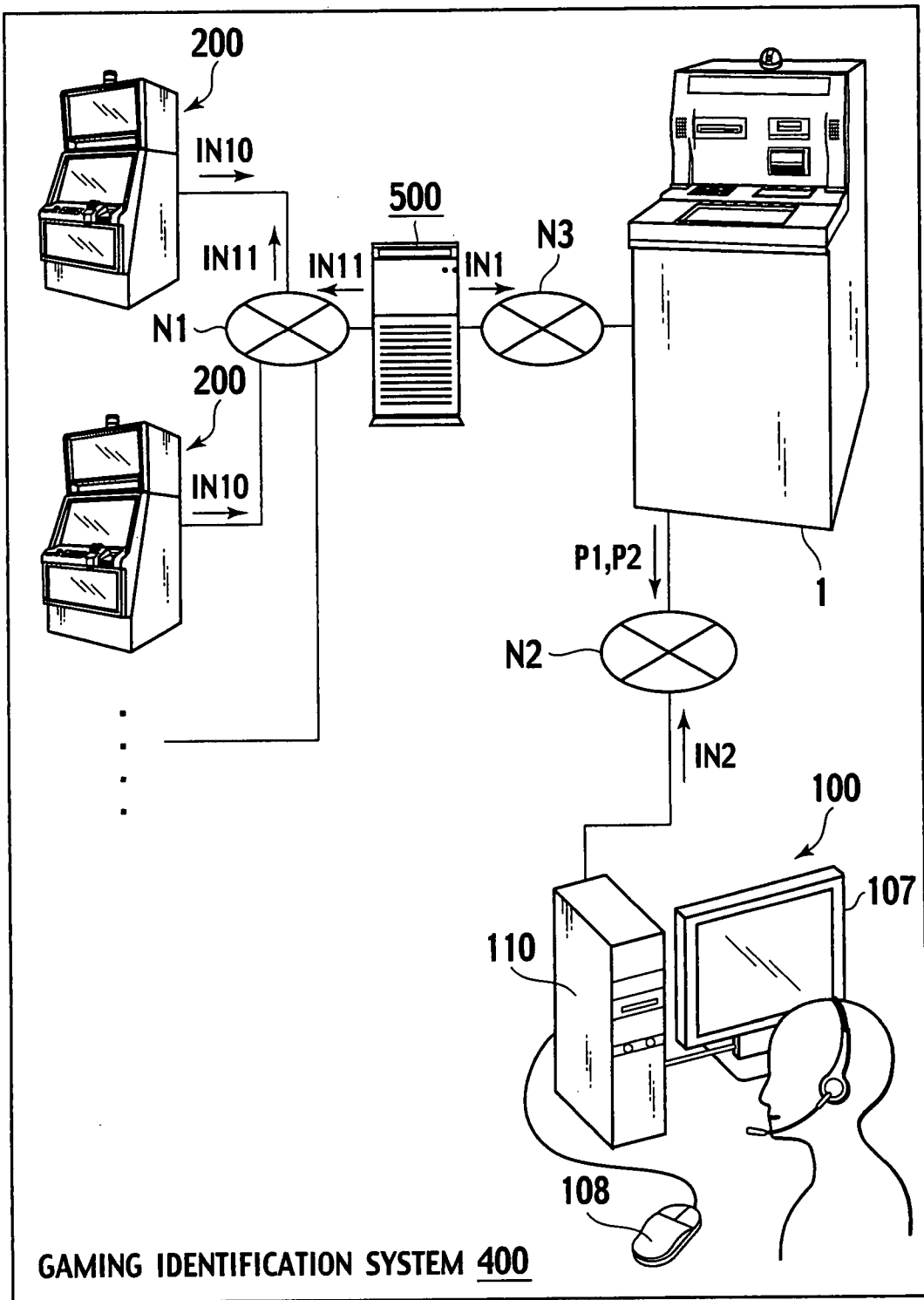

FIG. 16

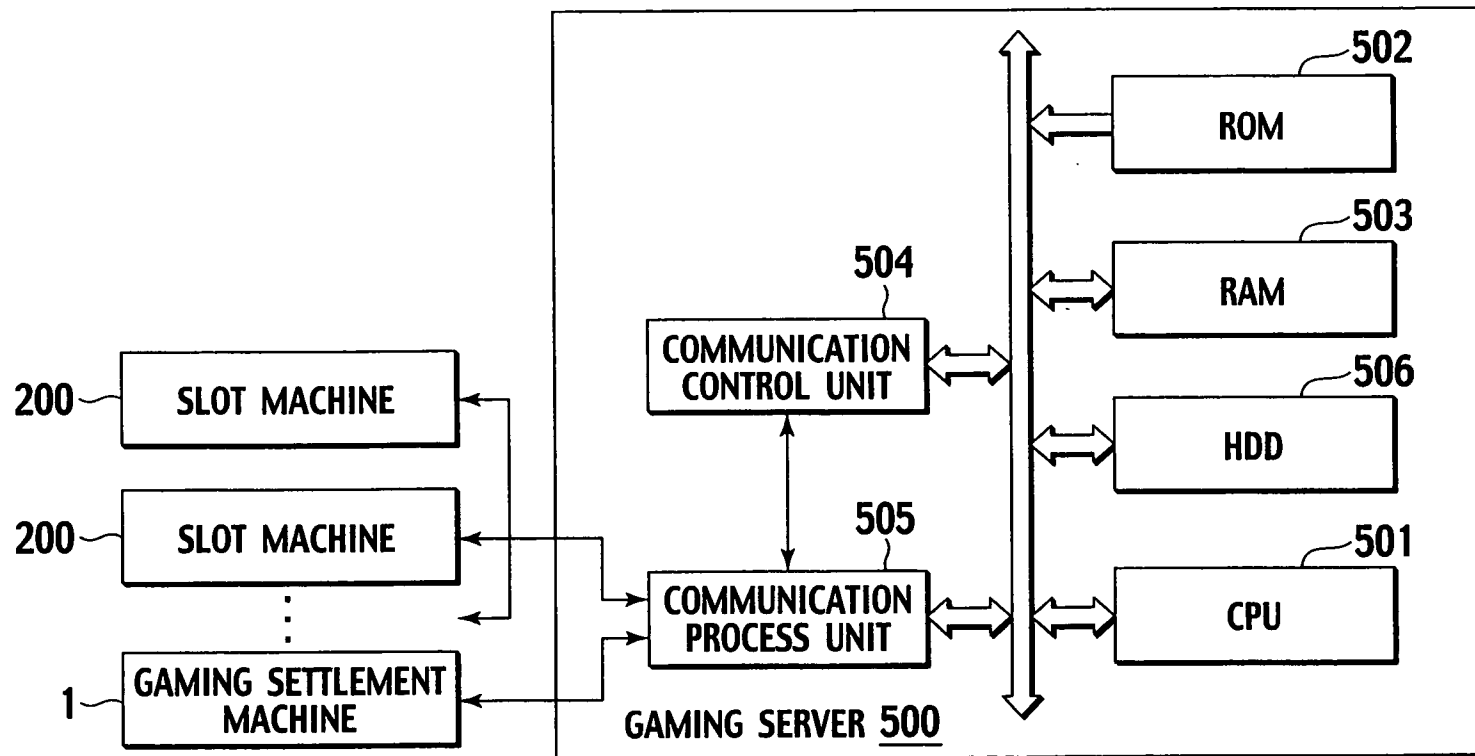

FIG. 17

