

(No Model.)

W. B. CULVER.
STEAM SEPARATOR.

No. 523,929.

Patented July 31, 1894.

Fig. 1.

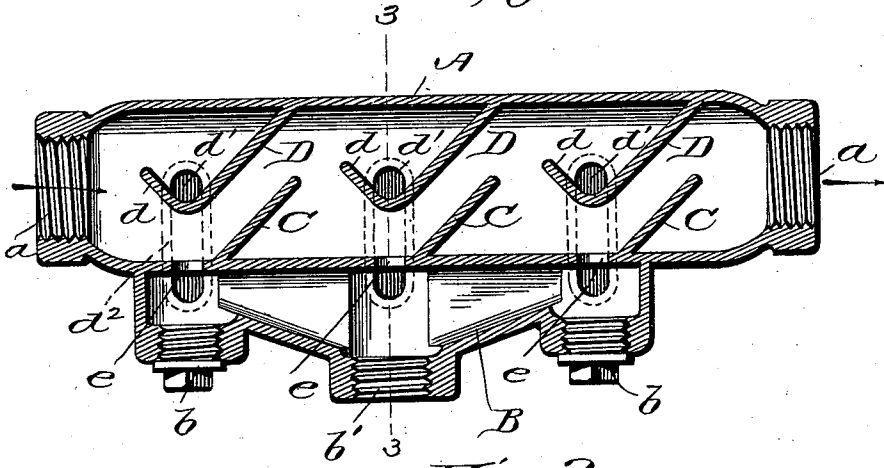

Fig. 2.

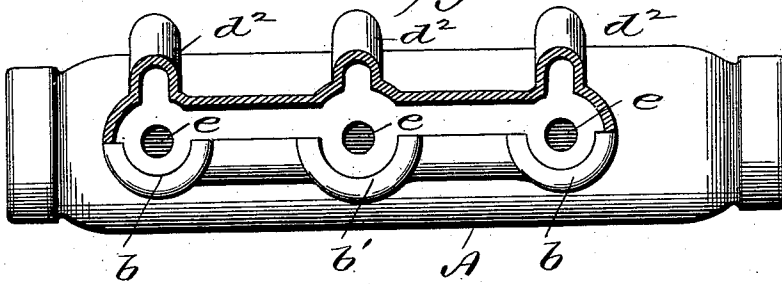
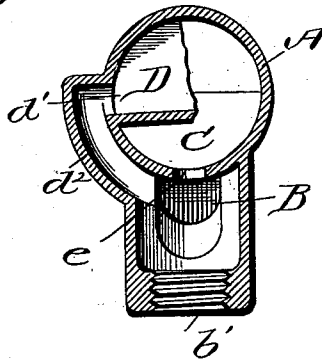

Fig. 3.



Witnesses
Samuel S. Hayden
Samuel Burrill Hillyard

Inventor
Willard B. Culver
By Attorneys *Robt. A. Lacey*

UNITED STATES PATENT OFFICE.

WILLARD B. CULVER, OF SCRANTON, PENNSYLVANIA.

STEAM-SEPARATOR.

SPECIFICATION forming part of Letters Patent No. 523,929, dated July 31, 1894.

Application filed September 11, 1893. Serial No. 485,275. (No model.)

To all whom it may concern:

Be it known that I, WILLARD B. CULVER, a citizen of the United States, residing at Scranton, in the county of Lackawanna and State of Pennsylvania, have invented certain new and useful Improvements in Steam-Separators; and I do hereby declare the following to be a full, clear, and exact description of the invention, such as will enable others skilled in the art to which it appertains to make and use the same.

This invention relates to mechanical appliances for extracting the humidity from steam and delivering the same in a dry state for commercial purposes.

This invention is designed for use chiefly in long lengths of pipe where the steam is to be used at a point distant from the generator and is particularly adapted for mining and engineering purposes. The superiority of dry over wet or humid steam is well known and the benefits and advantages of devices for extracting the moisture from wet steam have been appreciated and are well understood.

The invention consists of a separator having a series of alternately disposed deflectors and a discharge from each deflector whereby the moisture is condensed and removed from the path of the steam in a series of progressive steps so that the steam emerges from the separator in practically a dry condition to be used to the best possible advantage.

The invention also consists of the novel features and the peculiar construction and combination of the parts which will be hereinafter more fully described and claimed and which are shown in the annexed drawings in which—

Figure 1 is a central longitudinal section of a separator embodying my invention. Fig. 2 is a bottom plan view of the device showing the chamber into which the moisture from all the deflectors drains partly in section. Fig. 3 is a cross section on the line 3--3 of Fig. 1 parts of the deflectors being broken away.

The case A is long and provided at each end with threaded sockets *a* or other well known form of connection to which the steam pipes are coupled. A chamber B is provided on the under side of the case into which the moisture drains. This chamber is deepest at the middle point and slopes from the center toward each end to the body of the case, having screw

plugs *b* at each end on the lower side to facilitate cleaning and the coring in casting the device. A threaded socket *b'* is provided at the lowest point to receive the pipe by means of which the water is conveyed from the chamber B to the point of discharge. A series of deflectors C is provided at proper intervals within the case on the lower side to receive the impact of the steam and separate the moisture therefrom. A corresponding series of deflectors D is also provided within the case on the upper side. These deflectors are arranged in parallel relation and incline away from the steam entrance end of the case as shown. The upper series of deflectors are alternately disposed with reference to the lower series, and have their lower edge portions *d* recurved to form troughs to catch the drippings and convey the latter to side discharge openings *d'* which communicate with side passages *d²* leading into the chamber B. These troughs incline toward the discharge openings *d'* to cause a rapid discharge of the drippings so that the moisture may be removed as rapidly as possible from the path of the steam so that the moisture once separated may not again be taken up by the steam. Discharge openings *e* are formed in the lower side of the case at the base of the deflectors C for the moisture separated by the said deflectors. The lower deflectors extend up about half way the distance between the top and the bottom sides of the case and the upper deflectors project down about two-thirds the said distance thereby insuring the steam taking a tortuous path and impacting against each deflector of the alternate series.

To obviate loose joints and simplify the cost of construction and provide a light and compact device it is preferred to cast the device complete substantially as shown, the internal structure being cored as will be readily understood.

In practice the steam enters the separator as indicated by the arrow and striking the deflectors D and C is directed upward, the moisture removed trickles down on the said deflectors and escapes to the chamber B in the manner set forth. The steam directed upward by the first deflector D will turn back and pass with the incoming steam to the first deflector C. After the steam leaves the de-

flector C it will alternately pass up and down and over each deflector of the series to the delivery end of the separator. The liberated moisture at each deflector will have its own discharge to escape to the chamber B and thence to the point of delivery. This device separates the moisture from the steam by a series of successive steps and the water is conveyed away as quickly as formed thereby preventing any accumulation in the separator at any point to be taken up by the steam.

The length of the separator and the number of deflectors are immaterial and will depend upon the nature of the work and will be determined by trial.

It will be understood that the area or space between the opposing sides of the deflectors and between the ends of the deflectors C and the contiguous deflectors D will be a little more than the area of the steam pipe so as not to throttle or impede the passage of the steam.

Having thus described my invention, what I claim, and desire to secure by Letters Patent, is—

1. A steam separator having a series of de-

flectors pending from the top side, each deflector having a trough at its lowest point and a discharge, substantially as described.

2. A steam separator having a series of pending deflectors provided with troughs at the lowest point which incline throughout their length, and having a discharge for each of the said troughs, substantially as set forth.

3. The herein shown and described steam separator having a chamber on the bottom side, a series of deflectors C extended upward and having discharge openings *e*, a series of pending deflectors D having troughs at their lowest points which incline, and having a series of passages *d*² which communicate with the said troughs and with the said chamber, substantially as specified for the purpose set forth.

In testimony whereof I affix my signature in presence of two witnesses.

WILLARD B. CULVER.

Witnesses:

VAN BUREN HILLYARD,
FRANK H. BURNS, Jr.