



(72) MACRAE, DOUGLAS B., US

(72) O'CONNOR, DANIEL C., US

(71) INDEX SYSTEMS, INC., VG

(51) Int.Cl.⁶ H04N 5/44

(30) 1998/06/26 (60/090,805) US

(54) TERMINAL MIS SOUS TENSION EN VUE DU
TELECHARGEMENT D'UN GUIDE ELECTRONIQUE DES
PROGRAMMES

(54) TERMINAL POWERED ON FOR EPG DOWNLOAD

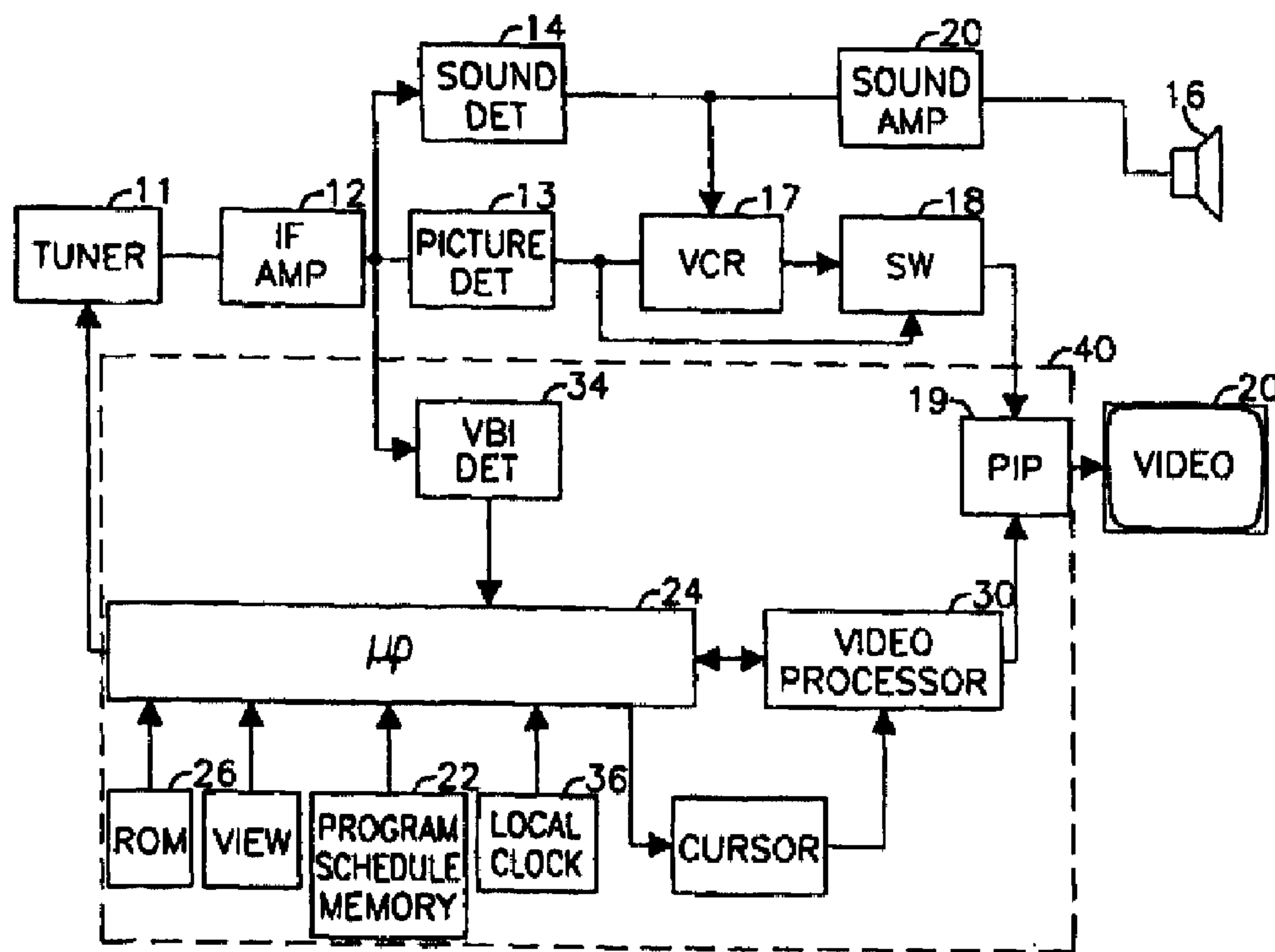

(57) Les données relatives à des émissions télévisées sont téléchargées par intermittence vers une pluralité de terminaux d'utilisateur équipés d'un récepteur (31) de données, d'une mémoire (22) destinée à enregistrer les données relatives aux émissions télévisées, d'un générateur (19) d'un guide électronique des programmes affichable à l'écran, d'un microprocesseur (24), et d'un écran (20) de télévision servant à afficher les émissions télévisées et le guide électronique des programmes. Les

(57) Television program data is intermittently downloaded to a plurality of user terminals equipped with a data receiver (34), a memory (22) for storing television program data, an on-screen electronic program guide generator (19), a microprocessor (24), and a television monitor (20) for displaying television programs and an electronic program guide. The data receivers are normally powered off and powered on at regular intervals to receive transmitted program data.

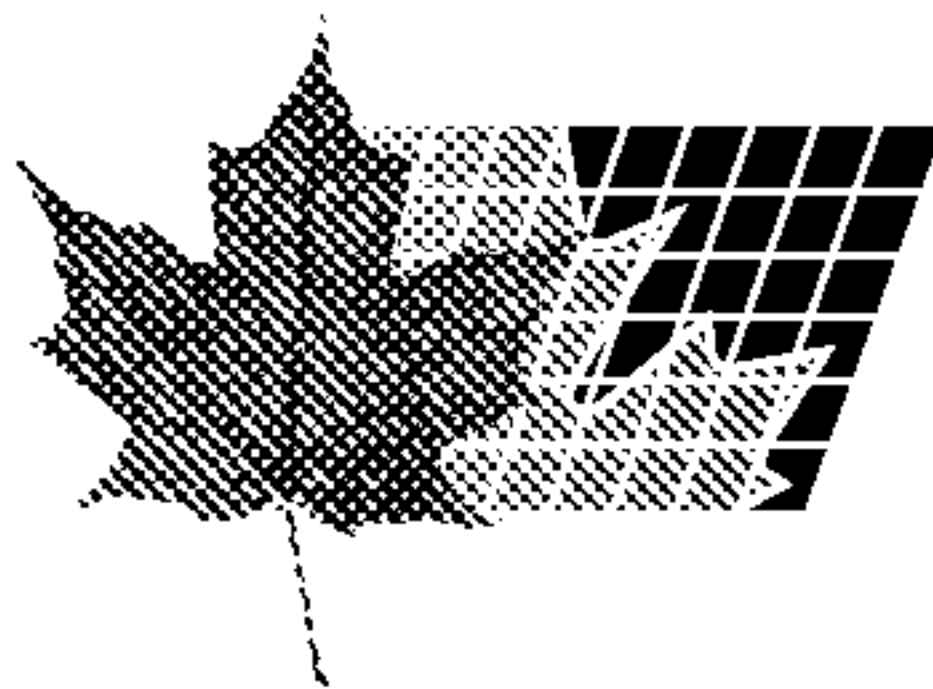

(21) (A1) **2,335,936**

(86) 1999/06/26

(87) 2000/01/06

récepteurs de données sont normalement mis hors/sous tension à intervalles réguliers afin de recevoir les données relatives aux émissions transmises. Ces données sont enregistrées dans la mémoire (22). Le microprocesseur (24) est configuré pour transférer les données relatives aux émissions télévisées de la mémoire (22) au générateur en réponse aux commandes de l'utilisateur, et pour commander le générateur de manière que celui-ci génère un signal pilote vidéo représentatif d'un guide des programmes télévisés affichable à l'écran. Le signal pilote est couplé au générateur et à l'écran pour afficher le guide des programmes affichable à l'écran. Plusieurs régimes sont utilisés pour la mise sous/hors tension du syntoniseur.

The transmitted program data is stored in the memory (22). The microprocessor (24) is configured to transfer television program data from the memory (22) to the generator in response to user commands and to control the generator to generate a video drive signal representative of an on-screen television program guide. The drive signal is coupled to the generator to the monitor to display the on-screen program guide. Various regimes are employed to turn the tuner on and off.



PCT

WORLD INTELLECTUAL PROPERTY ORGANIZATION
International Bureau

INTERNATIONAL APPLICATION PUBLISHED UNDER THE PATENT COOPERATION TREATY (PCT)

(51) International Patent Classification ⁶ : H04N 5/44	A1	(11) International Publication Number: WO 00/01141 (43) International Publication Date: 6 January 2000 (06.01.00)
(21) International Application Number: PCT/US99/14401 (22) International Filing Date: 26 June 1999 (26.06.99) (30) Priority Data: 60/090,805 26 June 1998 (26.06.98) US (71) Applicant (for all designated States except US): E GUIDE, INC. [US/US]; West Tower, 7th floor, 9100 Wilshire Boulevard, Beverly Hills, CA 90212 (US). (72) Inventors; and (75) Inventors/Applicants (for US only): MACRAE, Douglas, B. [US/US]; 23 Cart Path Road, Weston, MA 02493 (US). O'CONNOR, Daniel, C. [US/US]; 41 Hathaway Avenue, Beverly, MA 01915 (US). (74) Agent: RAHN, LeRoy, T.; Christie, Parker & Hale, LLP, Post Office Box 7068, Pasadena, CA 91109-7068 (US).	(81) Designated States: AE, AL, AM, AT, AU, AZ, BA, BB, BG, BR, BY, CA, CH, CN, CU, CZ, DE, DK, EE, ES, FI, GB, GD, GE, GH, GM, HR, HU, ID, IL, IN, IS, JP, KE, KG, KP, KR, KZ, LC, LK, LR, LS, LT, LU, LV, MD, MG, MK, MN, MW, MX, NO, NZ, PL, PT, RO, RU, SD, SE, SG, SI, SK, SL, TJ, TM, TR, TT, UA, UG, US, UZ, VN, YU, ZA, ZW, ARIPO patent (GH, GM, KE, LS, MW, SD, SL, SZ, UG, ZW), Eurasian patent (AM, AZ, BY, KG, KZ, MD, RU, TJ, TM), European patent (AT, BE, CH, CY, DE, DK, ES, FI, FR, GB, GR, IE, IT, LU, MC, NL, PT, SE), OAPI patent (BF, BJ, CF, CG, CI, CM, GA, GN, GW, ML, MR, NE, SN, TD, TG). Published <i>With international search report.</i>	

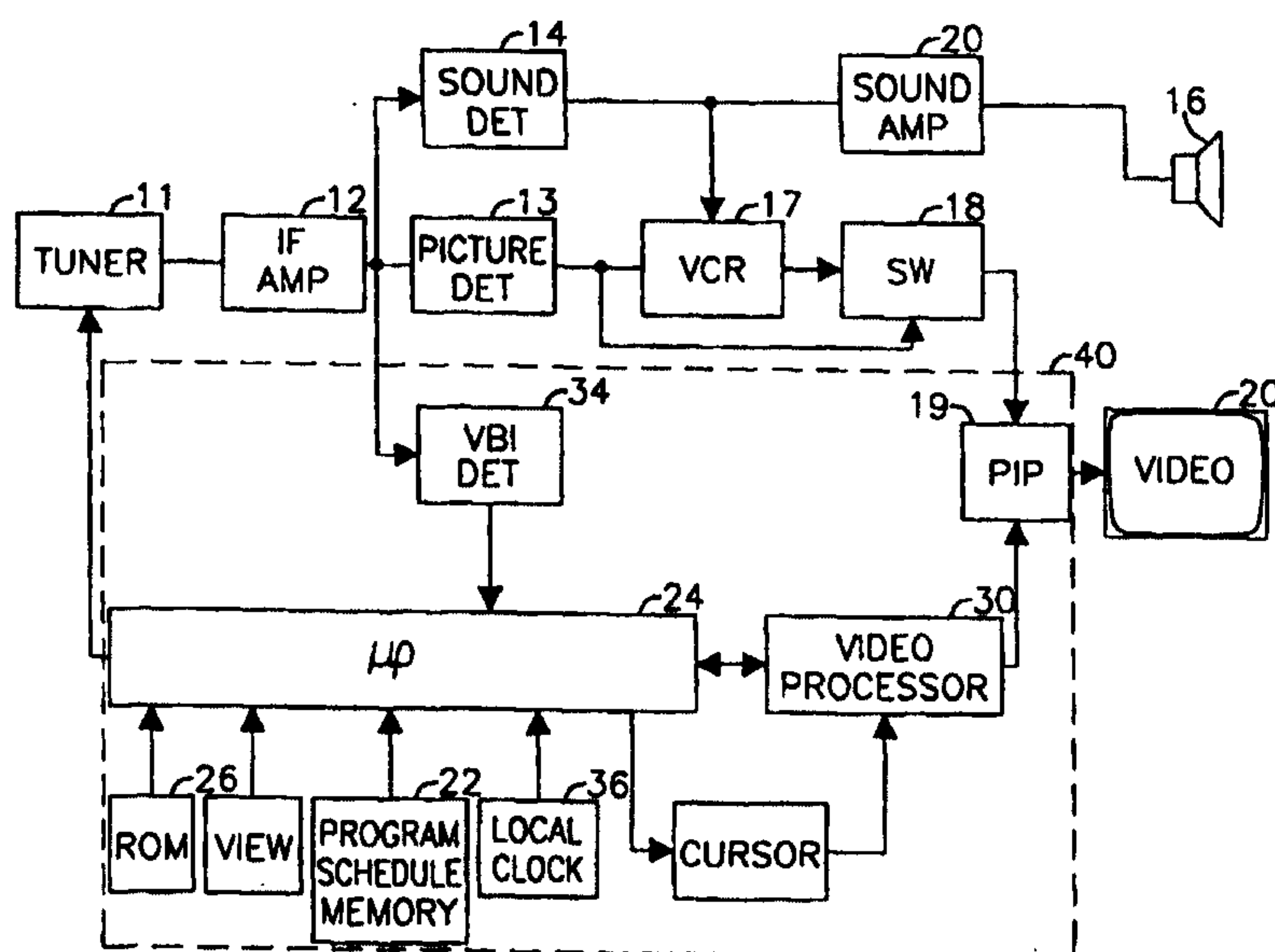
(54) Title: TERMINAL POWERED ON FOR EPG DOWNLOAD**(57) Abstract**

Television program data is intermittently downloaded to a plurality of user terminals equipped with a data receiver (34), a memory (22) for storing television program data, an on-screen electronic program guide generator (19), a microprocessor (24), and a television monitor (20) for displaying television programs and an electronic program guide. The data receivers are normally powered off and powered on at regular intervals to receive transmitted program data. The transmitted program data is stored in the memory (22). The microprocessor (24) is configured to transfer television program data from the memory (22) to the generator in response to user commands and to control the generator to generate a video drive signal representative of an on-screen television program guide. The drive signal is coupled to the generator to the monitor to display the on-screen program guide. Various regimes are employed to turn the tuner on and off.

1

TERMINAL POWERED ON FOR EPG DOWNLOAD**CROSS-REFERENCE TO RELATED APPLICATION**

5

This application claims priority of U. S. provisional application 60/090,805. filed on June 26, 1998, the disclosure of which is incorporated herein by reference.

BACKGROUND OF THE INVENTION

10

This invention relates to the field of television and, more particularly, to a system for the intermittent transmission of data for use in displaying television program guide information or other data.

15

Television program schedule systems, such as the one disclosed in application Serial No. 08/475,395, receive data transmitted in the vertical blanking interval (VBI) of a TV channel. Typically, the TV receiver must be powered on and tuned to the proper channel for the data to be received by the schedule system. Since transmissions occur during the middle of the day and night, when viewers are not as likely to be watching television, users must leave the system powered on to be sure they receive new data. This method wastes energy and is expensive for the user.

20

SUMMARY OF THE INVENTION

25

According to the invention, television program data is intermittently downloaded to a plurality of user terminals equipped with a data receiver, a memory for storing television program data, an on-screen electronic program guide generator, a microprocessor, and a television monitor for displaying television programs and an electronic program guide. The data receivers are normally powered off and powered on at regular intervals to receive transmitted program data. The transmitted program data is stored in the memory. The microprocessor is configured to transfer television program data from the memory to the generator in response to user commands and to control the generator to generate a video drive signal representative of an on-screen television program guide. The drive signal is coupled to the generator to the monitor to display the on-screen program guide. Various regimes are employed to turn the tuner on and off.

30

A feature of the invention is to transmit time correction packets with EPG data so real time clocks in all the user terminals can be synchronized to turn on at the same time for receipt of EPG data.

35

Another feature of the invention is to transmit instruction packets with the EPG data. One such instruction is to turn the tuner on a designated time to a designated channel. This allows for flexibility in the time and channel of the transmission of the EPG data.

1 DESCRIPTION OF THE DRAWINGS

The features of specific embodiments of the best mode contemplated of carrying out the invention are illustrated in the drawings, in which:

FIG. 1 is a diagram of the communications network employed in the transmission of data.

5 FIG. 2 is system block diagram of a television program guide integrated with typical TV related devices.

FIG. 3 is an illustration of a data transmission packet.

FIG. 4 is an illustration of the header of a data transmission packet in FIG. 3.

10 DETAILED DESCRIPTION OF THE INVENTION

In the following embodiments of the invention, reference numerals are used to represent components. If the features of all the embodiments are incorporated into a single system, these components can be shared and perform all the functions of the described embodiments.

15 **Data Transmission**

As is seen in figure 1, television schedule data from the master database 51 and master time data from the master clock 50 are sent to carrier channels via a communications circuit 52. Each carrier channel (public television, CNN, NBC, etc.) then transmits the data in the vertical blanking interval (VBI) of their specific broadcast channel. Each carrier channel has a distribution infrastructure in place for their channel, typically consisting of a satellite uplink 53 and a satellite network. The channels are then received by local affiliates and/or local cable companies 55 and telecast 56 to the user's equipment 57, 58 & 59.

20 In order to receive schedule data the television receiver must be turned on and tuned to the data provider channel. For example, if the data provider channel is channel 7, the television must first be tuned to channel 7 before schedule data can be received.

In one embodiment, data is transmitted during the first five minutes of each hour. If the user is not watching TV at this time, the terminal will signal the tuner (figure 2, item 11) to power on and tune to the proper channel. If the user is watching a different channel when the schedule system attempts to download data, or changes channels during the download, the download is skipped. The data transmitted each hour includes instructions to the terminal, targeted data using a filter and database updates. The downloads are spaced one hour apart over a 24-hour period to provide a high probability that during one of those attempts a user will not have the television tuned to another channel. It is unlikely that someone will be watching television at all twenty four of these data downloading intervals.

35 In an alternate embodiment several additional features could be incorporated, such as: Schedule data updates can occur on an individual basis for each channel. A warning message can be displayed on the screen of the tv monitor after some number of downloads are skipped,

1 informing the user that data may not be available until a download is completed. Each channel
 provider can supply schedule updates in the VBI signal for that channel. When the user selects
 a channel for display the schedule system can interrogate the VBI on that channel and receive
 schedule updates. The database can also be revision controlled, allowing terminals to receive
 5 incremental updates of data as needed.

The receiver turn on and turn off times and the channel on which the data is transmitted
 are stored in ROM: the microprocessor is programmed to process downloaded EPG data, data
 updates, and instructions, to compare the stored turn on and turn off times with a real time clock,
 to turn the tuner on or off when the comparison detects a match, and to filter the data that is
 10 stored in the program schedule memory

FIG. 3 illustrates a download packet used for the transmission of system data. The packet
 begins with a packet header 60 containing a packet ID number used to distinguish this packet
 from other packets. The packet header also contains the number of bytes in the packet and a
 CRC check bit for error detection.

15 The packet header is followed by the payload data 61. The payload data contains the
 information being transmitted to the terminal. In addition to program data (i.e. the database of
 programing information), various other types of information are contained within the payload
 data, including: System commands instructions, filters, and time synchronization information.

20 The packet payload data is followed by the end of packet message 62. This field indicates
 to the system that the end of the packet has been reached.

After receiving a packet the system checks the CRC to detects any transmission errors,
 and then extracts the payload data for procession. In the current embodiment the system only
 receives packets - it has no method of transmitting information. Therefore, any lost or corrupt
 packets are not resent to the terminal and that data is lost.

25 In an alternate embodiment, designed to operate with digital television data packets are
 transmit in a digital data stream with a digital television signal to the terminals.

System Overview

30 FIG. 2 describes a system block diagram of a television program guide 40 integrated with
 typical TV related devices. The primary input source of television signals 10, such as a
 terrestrial antenna or a cable, is connected to a television tuner 11. The output of tuner 11 is a
 modulated intermediate frequency signal containing video and audio television information.
 Tuner 11 is connected by an intermediate frequency amplifier (IF AMP) 12 to a picture detector
 (PICTURE DET) 13, a sound detector (SOUND DET) 14, and VBI detector (VBI DET) 24
 35 which produce base band video, audio signals and transmitted program data, respectively. The
 audio signal is coupled by a sound amplifier (SOUND AMP) 15 to a loudspeaker 16. The video
 signal is coupled by a video amplifier not shown to one input of a switch 18. The VBI signal is
 coupled to the television program guide microprocessor (μ P) 24. The microprocessor is

WO 00/01141

PCT/US99/14401

1 programmed to execute the described functions and always remains turned on so it can control the
described functions. Sound detector 14 and picture detector 13 are connected to the audio and
video inputs, respectively, of a video cassette recorder (VCR) 17. (Alternatively, television
5 signal source 10 could be directly connected to the RF input of VCR 17, if its internal tuner and
demodulating circuitry is to be utilized.) The output of VCR 17 is connected to the other input
of switch 18. The output of switch 18 is connected to one input of a conventional
picture-in-picture (PIP) integrated circuit chip 19. The output of PIP chip 19 is connected to the
video input of a television receiver or monitor (TV) 20 having a screen (not shown).

Master clock 50 periodically sends synchronizing signals to local clocks 36 at the user
10 terminals. Specifically, a data signal representing the current Greenwich Mean Time (GMT) is
sent the user terminals and the microprocessor at the user terminals corrects the GMT for a local
offset time, which is determined by having the user input the postal zip code where he is located
as disclosed in PCT published application WO97/25813. As a result, all the user terminals are
in time synchronism with master clock 50. At regular predetermined intervals, data is
15 transmitted from master database 51 on a predetermined channel. If tuner 11 is turned off at a
user terminal, microprocessor 24 is programmed to turn on tuner 11 to the predetermined channel
at the same time as the data is being transmitted from master database 51 to conserve power. At
the end of the data transmission, a data instruction turns off tuner 11. It should be understood
that when tuner 11 is turned on and off in accordance with the invention, this includes IF AMP
20 12 and VBI DET 34, i.e. the other components necessary to recover the data from the television
signal. The regularly transmitted data can either be payload data, which is the ultimate data
utilized by the user, or instructional data, which tells tuner 11 when to turn on again to receive
the ultimate data utilized by the user.

25

Processing Data

Time packets

Each terminal also maintains accurate local time by receiving periodic updates from the
master clock 50 in the data stream. Each time an update is received the μ P compares the
received time with the current time stored in the local clock 36. If there is a difference between
30 the two times, the μ P adjusts the local clock to the master clock as needed. The μ P can also track
trends in the local time correction, and can not only adjust the local clock but the rate at which
the clock runs. For example, if the first update requires an time adjust of plus 1 minute the μ P
first makes the adjustment, and then increases the clock rate by 1/60. After several time updates
(iterations) the local clock is very accurate.

35

So as to limit the amount of data transmitted, a single Universal Time (UT) is telecast to
all terminals. This eliminates the need to transmit a different time for each time zone (i.e. EST
1400, CST 1300, PST 1200, etc). During initial set up, each user inputs a time zone offset from
UT (i.e. pacific standard time is -7 hours from UT). Each time an update is received the μ P

WO 00/01141

PCT/US99/14401

1 adjusts the time to local time by performing the subtraction. Any propagation delay of the time packet is known and would be within the transmission system's tolerance.

Instructions

5 Instructions tell the terminal to perform a particular task. In the present embodiment instructions include: go back to sleep - if there is no new data to receive, change to another channel - to receive further instructions and/or data, to wake up at a different time, to receive new data on this channel now, or execute a filter or set of filters.

10 Filters

A filter is a set of conditions that are matched, or not matched, based on information stored within each terminal. Conditions could include: The terminal's software version, the zip code where the terminal is located, or even areas of viewer interest (i.e., sports, movies, news, etc). If a filter is matched, then the terminal performs an instruction or selectively grabs data.

15 Filters are used to limit the terminals that perform a specific instruction or grab selected data to fewer than all the television receivers to which the television signals are sent..

Data

20 Data is information about programs that air on television. Such data typically includes the channel, time, day, length and specific content of a television program. This data is then stored and sorted to provide the user pertinent information about the programs that air on his television.

25 The following is one example of how the television receiver can be turned on and off to download data during data transmission sessions assuming that the default data channel for this example is set to channel 17:

24:59 pst The microprocessor 24 checks to see if tuner 11 is on and tuned to channel 17. If not, it sends a command to the tuner to power on and tune to channel 17. If tuner

30 11 is already turned on to channel 17 because the television receiver is currently in use, it remains on to receive data. If tuner 11 is already turned on to a different channel because the television receiver is currently in use, the download is skipped and the microprocessor sequences a counter to indicate the skipped download. (When the counter reaches a prescribed number, the microprocessor causes the

35 warning message to be displayed on the monitor.)

00:01 pst Tuner 11 being turned on, VBI detector 34 receives a time packet and forwards it to the microprocessor. The microprocessor first sends a command to tuner 11 to

WO 00/01141

PCT/US99/14401

- 1 power off, then checks the local clock 36, and compares it with the time in the packet. If there is a difference, the microprocessor adjusts the local clock.
- 5 00:02 pst Tuner 11 turns back on and the VBI detector receives a filter and instruction packet. The filter is set such that all terminals with zip codes >92800 should tune to channel 29 at 07:35 UT for new data. The instruction packet is forwarded to the microprocessor.
- 10 00:03 pst Responsive to the instruction packet, the microprocessor sends a command to tuner 11 to power off. Assuming that the terminal's zip code is set as 92855, the microprocessor also schedules the data download responsive to the instruction packet..
- 15 00:35 pst The microprocessor checks to see if tuner 11 is on and tuned to channel 29. If not, it sends a command to the tuner to power on and tune to channel 29. If tuner 11 is already turned on to channel 29 because the television receiver is currently in use, it remains on to receive data. If tuner 11 is already turned on to a different channel because the television receiver is currently in use, the download is skipped and the microprocessor sequences the counter to indicate the skipped download. (When the counter reaches a prescribed number, the microprocessor causes the warning message to be displayed on the monitor.)
- 20 00:36 pst The VBI detector receives data packets and forwards them to the microprocessor. Once the last packet is received, the microprocessor sends a command to the tuner to power off.
- 25 00:59 pst The described process is repeated at this time and at the same time every hour thereafter.

30 It should be noted that if no filter is used, tuner 11 starts to receive downloaded data when it is turned back on at 00:02 pst responsive to the instruction packet .

35 The following is another example of how the television receiver can be turned on and off to download data during data transmission sessions: The instruction packets are transmitted at regular or irregular intervals that are not known to tuner 11. Tuner 11 is periodically turned on for a time period, T^1 , that is longer than the time period, T^2 , required to receive an instruction packet. For example if an instruction packet last two seconds, e.g., $T^1 = 2$ sec., tuner 11 might be turned on for a time period of 60 seconds, e.g., $T^2 = 60$ sec., so it is likely that an instruction

WO 00/01141

PCT/US99/14401

1 packet, if transmitted, overlaps with the time that tuner 11 is turned on. As in the other example,
when an instruction packet is received, it is stored and the microprocessor turns on to the
designated channel at the designated time to receive the data download. To insure that an
instruction packet is received before the EPG data stored in the terminal becomes obsolete or
5 stale, the microprocessor is programmed to shorten successively periods between tuner turn ons
until an instruction packet is received. For example, right after reception of an instruction
packet, the period between tuner turn ons could be one hour and thereafter could be shortened
by five minutes until the next instruction packet is received; thereafter the period between tuner
turn ons could be return to one hour and the cycle could be repeated.

10 The described embodiments of the invention are only considered to be preferred and
illustrative of the inventive concept; the scope of the invention is not to be restricted to such
embodiment. Various and numerous other arrangements may be devised by one skilled in the
art without departing from the spirit and scope of this invention. For example, other regimes
could be employed to turn the tuner on and off to reduce power consumption without loss of EPG
15 data. Further, although it is currently preferred to transmit the EPG data with the television
signal on a television channel, the EPG data could be transmitted over another data link, such
as for example a 930 Mz pager channel. In any case, the data receiver is turned on and off as
described above to reduce power consumption.

20

25

30

35

WO 00/01141

PCT/US99/14401

1 WHAT IS CLAIMED IS:

5 1. A method for intermittently downloading television program data to a plurality of user terminals equipped with a data receiver, a memory for storing television program data, an on-screen electronic program guide generator, a microprocessor, and a television monitor for displaying television programs and an electronic program guide, the method comprising the steps of:

10 normally powering the data receivers off;
intermittently transmitting television program data to the user terminals;
powering the data receivers on to intercept the transmitted program data;
15 storing the transmitted program data in the memory;
programming the microprocessor to transfer television program data from the memory to the generator in response to user commands;
programming the microprocessor to control the generator to generate a video drive
15 signal representative of an on-screen television program guide; and
coupling the generator to the monitor to display the on-screen program guide.

20 2. The method of claim 1, in which the data receiver comprises a television tuner and VBI decoder and the transmitting step comprises embedding the program data in a television signal received by the tuner.

25

30

35

FIG. 1

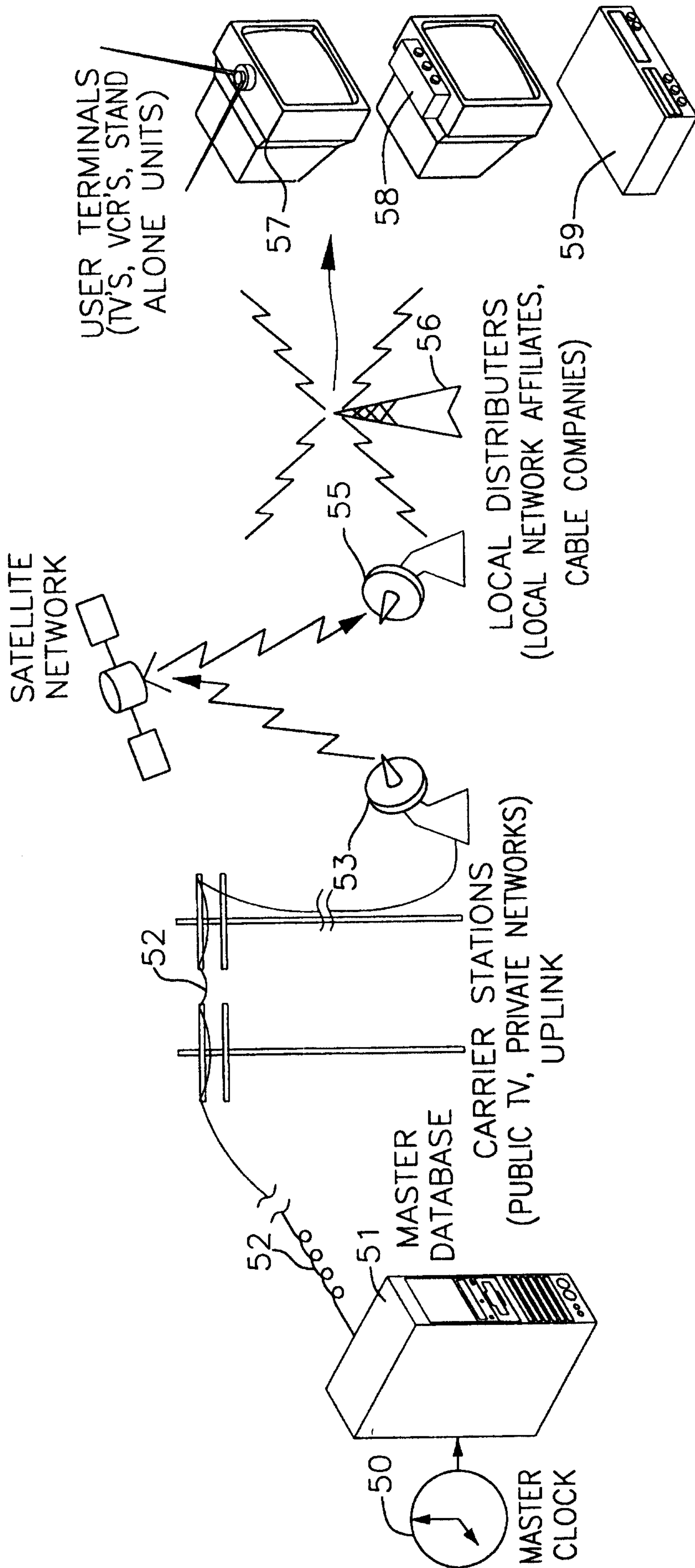

FIG. 2

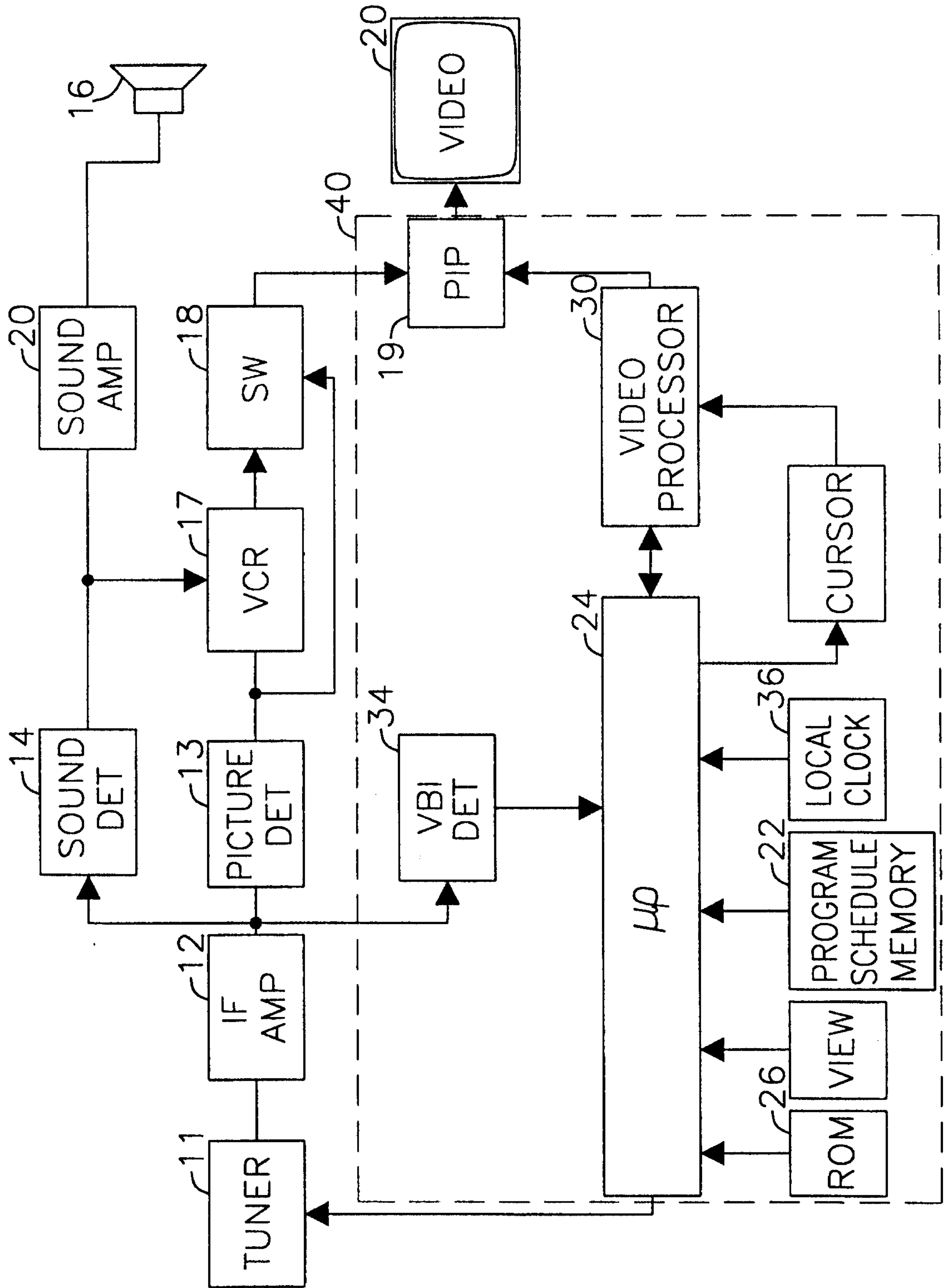

FIG. 3

TRANSMISSION PACKET

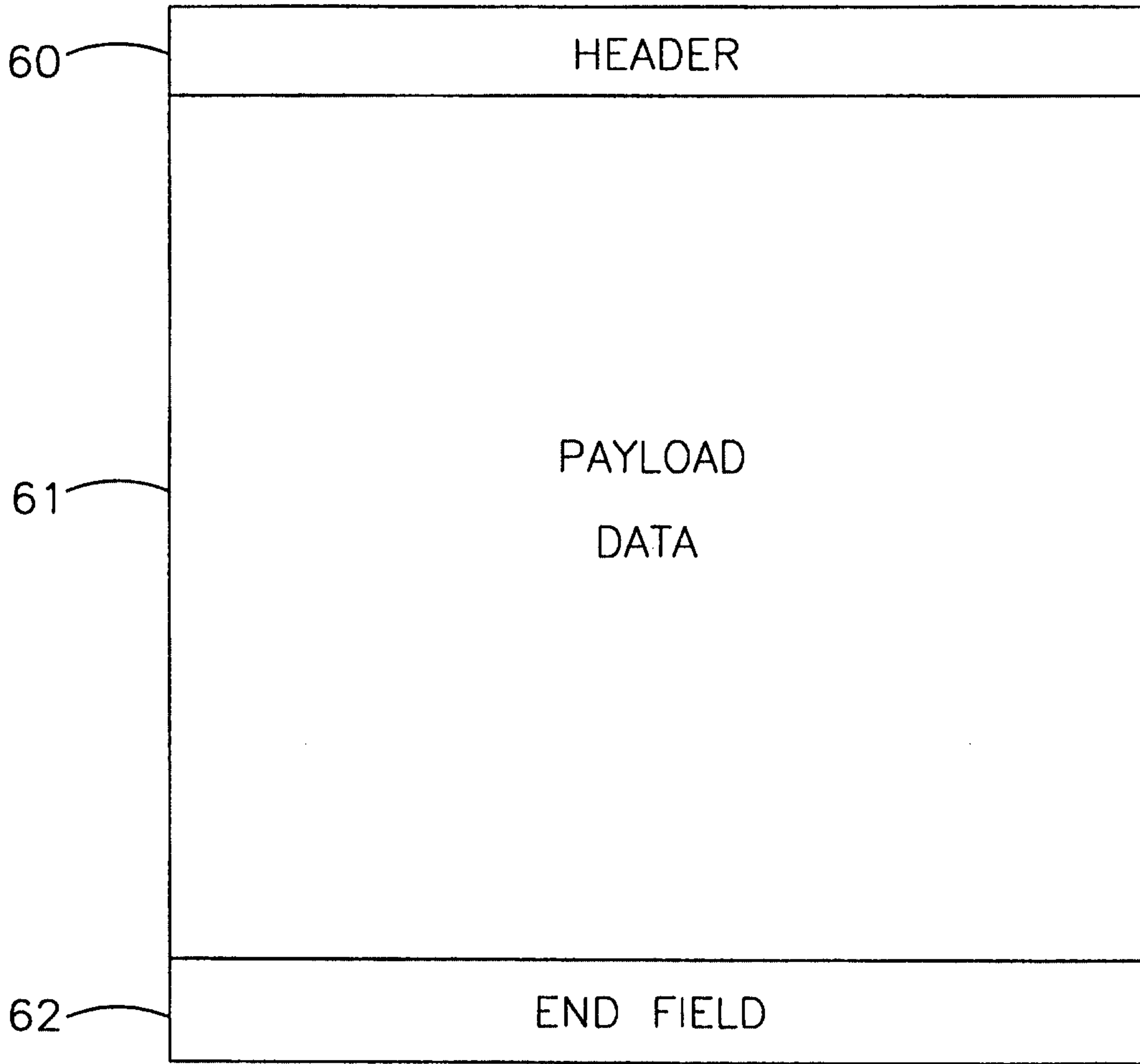

FIG. 4

TRANSMISSION PACKET HEADER

ID	NUMBER OF BYTES	CRC
----	-----------------	-----

