

N. STAFLIN.
 Watch-Regulators.

No. 140,090.

Patented June 17, 1873.

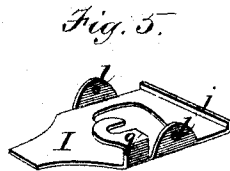
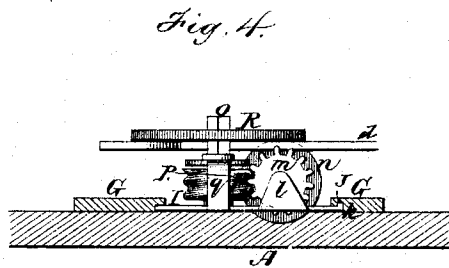
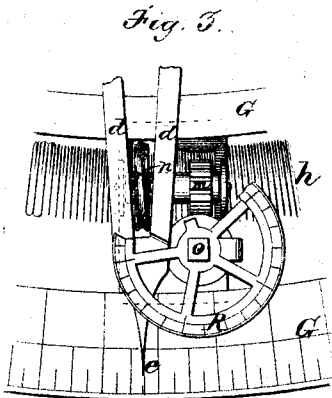
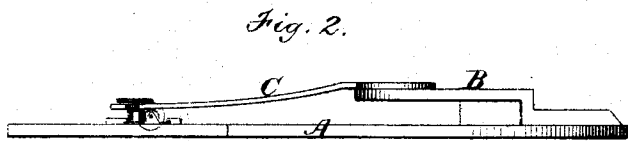
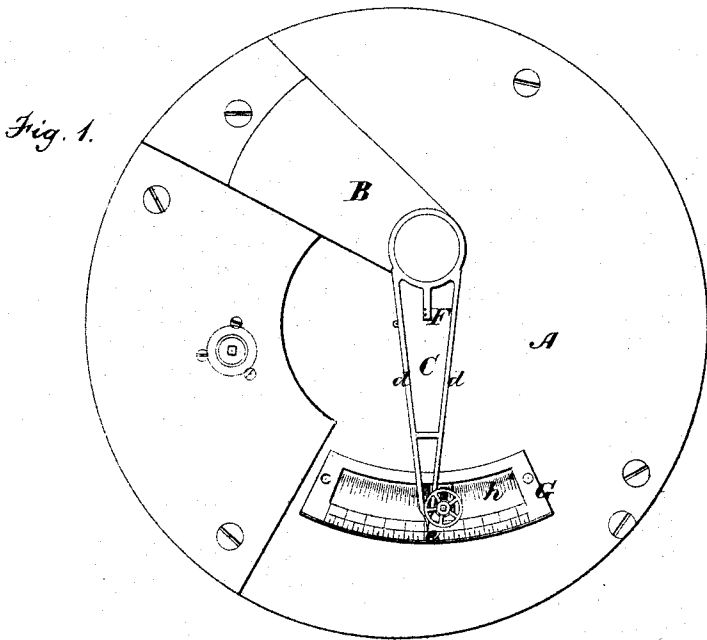

Witnesses.
 G. F. Brown,
 M. Ellsworth.

Inventor.
 N. Stafflin.
 by his Attys.
 Hill & Ellsworth.

UNITED STATES PATENT OFFICE

NICOLAS STAFLIN, OF CHICAGO, ILLINOIS.

IMPROVEMENT IN WATCH-REGULATORS.

Specification forming part of Letters Patent No. **140,090**, dated June 17, 1873; application filed October 12, 1872.

To all whom it may concern:

Be it known that I, NICOLAS STAFLIN, of Chicago, in the county of Cook and State of Illinois, have invented a new and Improved Watch-Regulator; and I do hereby declare the following to be a full, clear, and exact description of the same, reference being had to the accompanying drawings forming part of this specification, in which—

Fig. 1 is a plan view of the top plate of a watch. Fig. 2 is an edge view of the same, partly in section. Fig. 3 is an enlarged plan view of the regulator. Fig. 4 is an enlarged side view of the same, and Fig. 5 is a perspective view of the guide-plate by which the regulator is connected to the top plate of a watch.

Similar letters of reference in the accompanying drawings denote the same parts.

My invention has for its object to produce an improved regulator for watches, which shall be unaffected by the expansion and contraction of the metals under the influence of heat and cold; and to this end the invention consists, first, in the construction of the regulator; secondly, in the combination therewith of the devices by which it is operated; and, thirdly, in the construction of these devices, as I will now proceed to describe.

In the accompanying drawings, A is the top plate of a watch, and B the balance-bridge. C is the regulator, mounted in the usual manner upon the balance-bridge. It is composed of two narrow arms, *d d*, uniting at their outer ends to form a single point, *e*, and formed with a short arm, F, at its base, midway between the arms *d*. To this short arm the hair-spring of the watch is connected. G is the index-plate secured to the watch-plate A, so that the point of the regulator shall sweep over the graduations upon its outer arc. The index-plate is formed with a curved slot nearly its entire length, and the watch-plate A, within this slot, is cut to form a threaded segmental recess, *h*, concentric with the pivot of the regulator. I is a small guide-plate, placed transversely within the slot of the index-plate, the upturned flange *j*, at its inner end, entering a groove, *k*, in the wider surface of the plate G, and its outer or narrow end fitting a rabbet in the under edge of the plate, as shown. By

this construction the plate is guided in its movements through the slot, and prevented from turning therein by the flange and groove *j k*. *m* is a small pinion, and *n* a worm-wheel with a single thread mounted upon a short transverse shaft, having its bearings in upturned ears *l* upon the sides of the guide-plate, the center of which is cut out to permit the engagement of the worm-wheel with the threads of the segmental recess *h*. *o* is a vertical post provided with a horizontal worm-wheel, *p*, to engage with the pinion *m*. The post is held upon the guide-plate by fitting above the worm-wheel within a slot formed in an upturned arm, *q*, and by the contact of the worm-wheel *p* with the pinion. The guide-plate is struck up from a single piece of metal into the requisite form for the reception of its various attachments. The regulator is connected to the gearing of the guide-plate by being fitted over the vertical worm-wheel *n*, as shown in Figs. 1 and 3, so that such wheel shall be directly in line with the point *c* and the pivot of the regulator, as well as the pins by which the hair-spring is connected to the short arm F. R is a small wheel secured to the post *o* above the arm *q*, and provided with finer graduations than those upon the index-plate. By operating this wheel, or by turning the post with a suitable key, motion is communicated to the worm-wheel *n* through the medium of the worm-wheel *p* and pinion *m*, which wheel *n*, engaging with the threads in the segmental recess *h*, moves the guide-plate and its attachments through the index-plate, carrying with them the regulator to the desired adjustment. The graduations upon the operating-wheel indicate fractional parts of those upon the index-plate, and may be reduced to such a degree of fineness as to note the forty-thousandth or even a lesser part of the whole number of graduations upon such plate.

Inasmuch as watches necessarily vary considerably in their record of time, some running faster than others, I design to first set them at the factory to determine their variation, and then stamp upon a convenient part of the case or works of each the exact adjustment required to compensate for the variations, the adjustment being indicated by the num-

ber of revolutions, or parts thereof, to be given the operating-wheel. Instead of marking the watch itself, a paper or card of instructions may accompany each.

By arranging the point of connection between the regulator and its operating devices directly in line with its pivot and point *e*, and with the pins which connect the hair-spring to the arm *F*, the regulator contracts and expands equally upon each side of the wheel, and the expansion and contraction of the top plate of the watch does not change the position of the regulator with respect to the graduations upon the index-plate, because the only connection between the regulator and top plate is through the worm-wheel *m*, and this wheel, resting in one thread of the recess *h*, cannot be moved laterally.

Instead of forming the threaded segmental recess directly in the plate of the watch, it may be made in the index-plate, and for old watches I prefer this construction.

Having thus described my invention, what I claim is—

1. The sliding plate *I*, constructed as described, and carrying the pinion *m* and worm-wheels *n p*, for adjusting the regulator *C*, substantially as described, for the purpose specified.

2. The sliding plate *I*, having the upturned flange *j*, in combination with the watch-plate *A*, and the index-plate *G* having the groove *k* to receive the flange *j*, and a rabbet to receive the narrow end of the plate *I*, substantially as described, and for the purpose specified.

3. The combination of the graduated operating-wheel *R* with the sliding plate and its operating mechanism, the regulator *C*, the index-plate *G*, and the threaded segmental recess *h*, substantially as described, for the purpose specified.

Witnesses: NICOLAS STAFLIN.
 NATHAN K. ELLSWORTH,
 E. A. ELLSWORTH.