

Oct. 21, 1947.

M. E. FERNALD

2,429,263

NAIL CHUCK FOR NAILING MACHINES

Filed Aug. 23, 1944

2 Sheets-Sheet 1

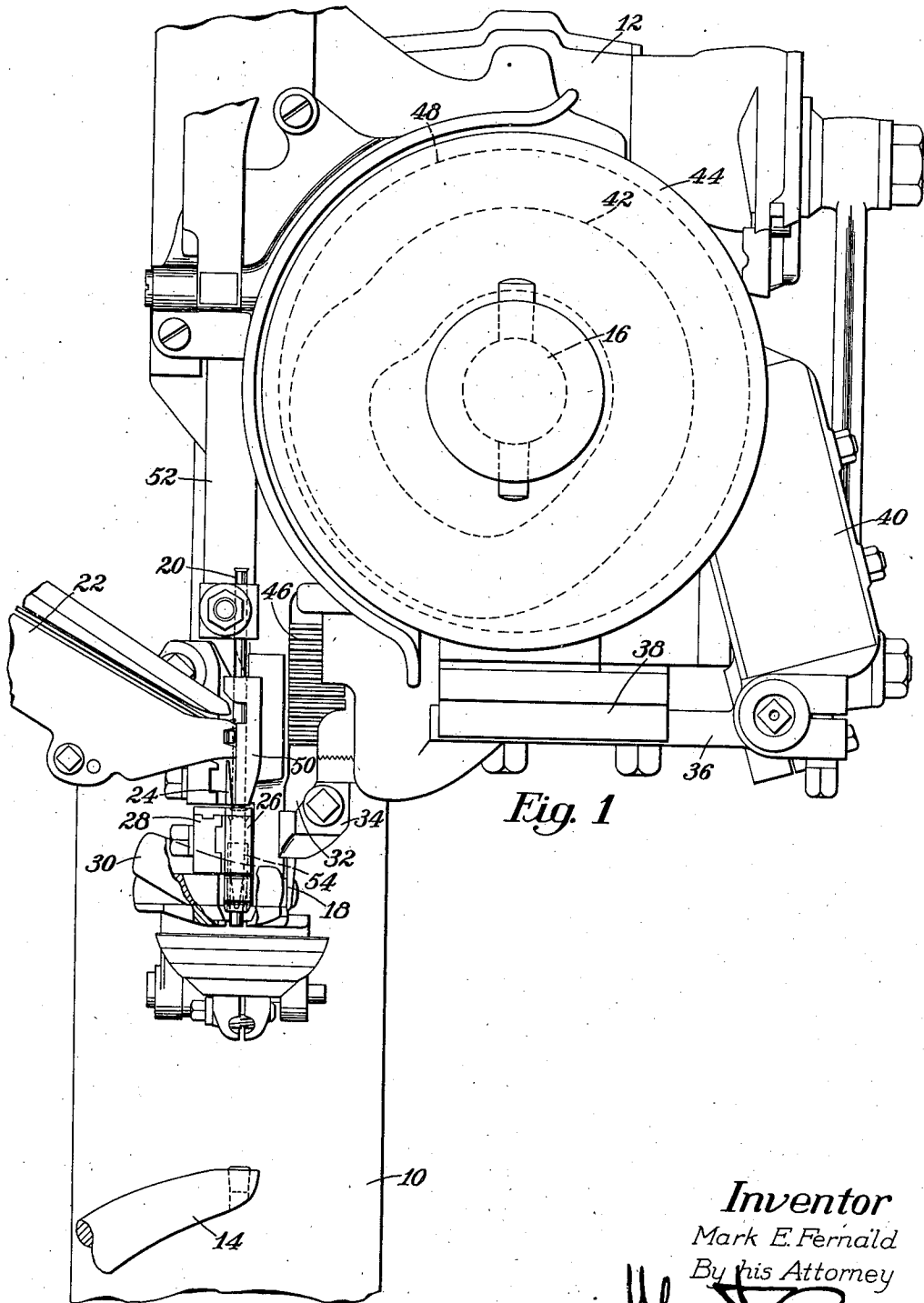

Fig. 1

Inventor
Mark E. Fernald
By his Attorney

Wm. J. Casey

Oct. 21, 1947.

M. E. FERNALD

2,429,263

NAIL CHUCK FOR NAILING MACHINES

Filed Aug. 23, 1944

2 Sheets-Sheet 2

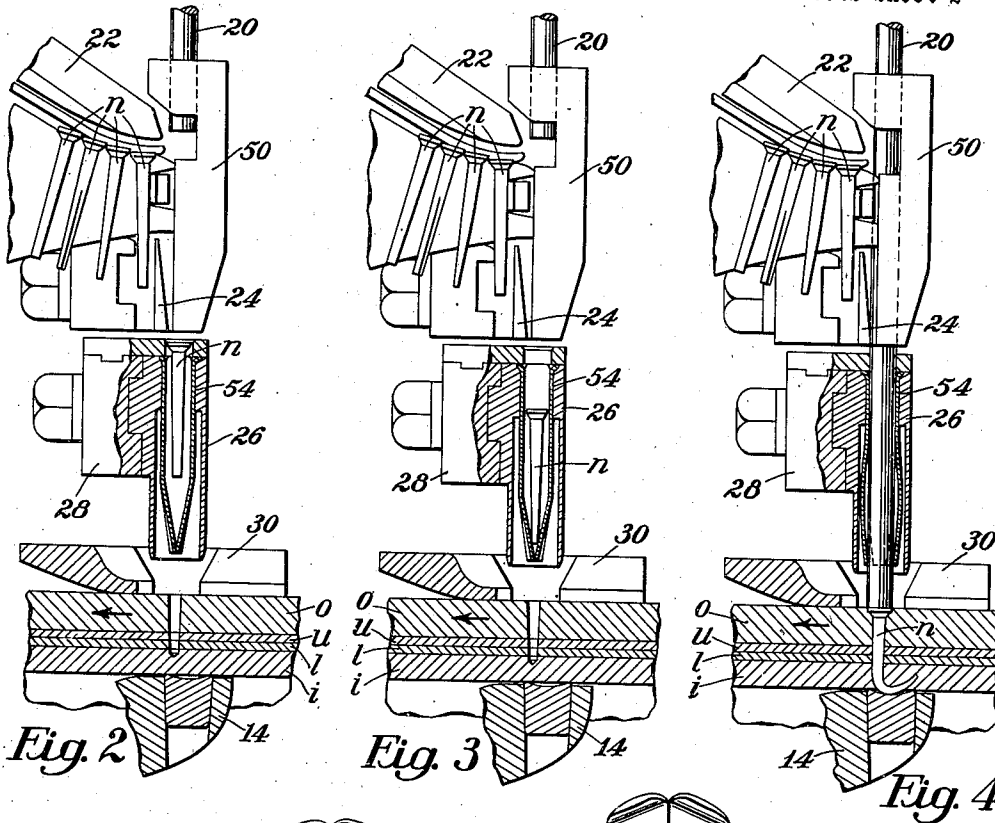

Fig. 2

Fig. 3

Fig. 4

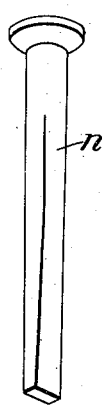

Fig. 5

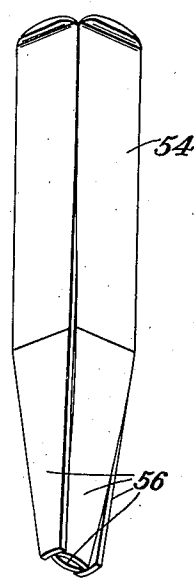

Fig. 6

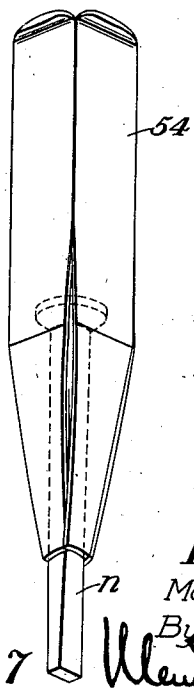

Fig. 7

Inventor
Mark E. Fernald
By his Attorney

UNITED STATES PATENT OFFICE

2,429,263

NAIL CHUCK FOR NAILING MACHINES

Mark E. Fernald, Beverly, Mass., assignor to
United Shoe Machinery Corporation, Flemington,
N. J., a corporation of New Jersey

Application August 23, 1944, Serial No. 550,703

3 Claims. (Cl. 1-5)

1

This invention relates to improvements in fastening inserting machines and is particularly concerned with so-called loose nailing machines adapted to insert chisel-pointed nails into work parts, such as parts of shoes.

In the manufacture of certain shoes it is customary to attach the outsole to the shoe bottom, at least in part, or to attach a heel base to the heel seat portion of the outsole by means of chisel pointed nails inserted by a machine of the above-mentioned type. Chisel-pointed nails are preferred by shoe manufacturers for these operations because they are easy to manufacture and hence they are cheaper than other nails suitable for the same purpose. However, a chisel-pointed nail can be satisfactorily clinched only in the direction at right angles to the broad sides of its point and, accordingly, if a chisel-pointed nail, prior to its insertion, is not properly oriented angularly about its longitudinal axis, there is no accurate control over the direction of its clinch. Loose nailing machines usually have a work supporting horn provided with a concave nail clinching face or anvil designed to clinch the nails in a predetermined direction, usually in the line of nail insertion and in a direction opposite to the direction of feed of the work. Thus, it may happen that a chisel-pointed nail, if not oriented properly, is crippled or bent in corkscrew fashion or is deflected laterally of the line of feed by the anvil with the danger that the nail point may emerge from the edge face of the outsole or the side face of the heel base.

It is, therefore, an object of the present invention to provide an improved mechanism adapted for use in connection with machines of the above-mentioned type, the mechanism serving to orient chisel-pointed nails about their longitudinal axes before they are driven so as to obtain full control over the direction of the clinch of the nails.

To this end and in accordance with an important feature of the invention, the illustrated fastening inserting machine is provided with nail orienting mechanism associated with the nail receiving throat commonly used in machines of this type, and adapted to turn each fastening about its longitudinal axis, if necessary, so that the fastening will be held in the throat in a predetermined position angularly about its longitudinal axis and will be inserted into the work parts by the driver while maintaining this predetermined position. Thus full control over the direction of the clinch of the inserted nail is obtained. As illustrated, the throat is provided with a nail guiding quill having a tapered lower end which

2

is formed by four spring jaws. The spring jaws are normally so located with relation to each other that two opposite jaws are in contact with each other at their lower edges and that the other two opposite jaws are in engagement with the side faces or edges of the contacting jaws. As a result of this arrangement, chisel-pointed nails which are dropped promiscuously into the throat are oriented by the quill angularly about their longitudinal axes so that the broad sides of the nail points, in the direction of which the clinch will be made, will be inserted into the work parts facing the line of feed.

These and other features of the invention will now be described in detail in connection with the appended drawings and will be pointed out in the claims.

In the drawings,

Fig. 1 is a front view of a part of the head of a loose nailing machine embodying the present invention;

Figs. 2, 3 and 4 are sectional views of the throat of the illustrated machine and associated mechanism showing the successive stages of the orientation of a chisel-pointed nail and its insertion into the work parts;

Fig. 5 is an enlarged view of a chisel-pointed nail;

Fig. 6 is an enlarged view of a quill constructed in accordance with the invention; and

Fig. 7 is a view similar to Fig. 6 with a chisel-pointed nail passing through the quill.

The invention is illustrated as embodied in a fastening inserting machine of the loose nailing type such as is disclosed in United States Letters Patent No. 1,030,775, granted on June 25, 1912, on an application filed in the name of George Goddu. Only such features of the general organization of the machine as it is necessary to refer to for an understanding of the invention will be described herein in detail.

The illustrated machine comprises a column 10 (Fig. 1) which carries a head 12 supporting the operating instrumentalities and their driving mechanisms and which also carries a work supporting horn 14. In the illustrated example the work comprises a shoe shown in section in Figs. 2, 3 and 4 and being composed of an outsole *o*, an upper *u*, a lining *l* and an insole *i* to be secured together by a nail inserted therethrough and clinched against a special clinching face provided in the tip of the horn 14.

For actuating the operating instrumentalities of the machine a cam shaft 16 (Fig. 1) is mounted in suitable bearings in the head 12. The prin-

principal operating instrumentalities comprise an awl 18, a driver 20, a raceway 22, a nail separator 24 and a nail receiving throat 26. In the operation of the machine through one cycle, the awl is first caused to pierce the work and then is moved laterally in the machine in the direction of feed while in piercing engagement with the work to impart a feed movement to the work.

After the work has been fed a distance sufficient for the awl hole in the work to be located in register with the vertical movement of the driver 20, the awl is withdrawn from the work and returned to its initial position. While the awl pierces and feeds the work the separator 24 and throat 26 are in a retracted position so as not to interfere with the feeding of the work and the lateral motion of the awl. Thereupon the separator and the throat are advanced into their forward operating position during which movement the separator separates the lowermost nail in the raceway 22. This nail is dropped into the throat 26 and held therein to be engaged by the descending driver which is caused to move through the throat and to insert the nail held therein into the awl hole previously made in the work. As stated the point of the nail is clinched against the tip of the horn 14.

For the purpose of moving the separator 24 and the throat 26 forwardly and rearwardly in the machine, they are both mounted on a slide 28 which is operated by suitable lever mechanism (not shown) actuated from the cam shaft 16 in time relation to the movements of the other operating instrumentalities. The machine is also provided with a work abutment 30 between which and the upper end of the horn 14 the work parts are clamped prior to a nail inserting operation.

Considering briefly the awl mechanism it will be noted that the awl 18 is secured to a vertically movable awl bar 32 which is mounted in an awl frame 34 arranged for horizontal sliding movement in the direction of feed. The awl frame is provided with a dovetailed guide 36 movable in a guideway provided in a bracket 38 bolted to the head 12 of the machine. For moving the awl frame 34 horizontally in the direction of work feed so as to impart a work feeding movement to the awl, it is pivotally secured to a feed lever 40 the fulcrum of which is adjustable so that the extent of feed movement imparted to the work may be adjusted. The feed lever 40 carries a follower (not shown) engaged in a cam groove 42 provided in the rear face of a disc 44 secured to the forward end of the cam shaft 16.

To reciprocate the awl 18 vertically the awl bar 32 is provided with a rack which is engaged by a gear segment 46 provided on a lever (not shown). The lever is rocked about a fixed fulcrum and to this end engages by means of a cam follower (not shown) a cam groove provided in a barrel cam 48 secured to the cam shaft 16.

The driver 20 is vertically movable in a driver guide 50 mounted in the machine head and is secured to a vertically reciprocated driver bar 52 actuated by rack and lever mechanism (not shown) which mechanism is driven by another cam groove provided in the barrel cam 48.

The illustrated machine is particularly adapted to insert chisel-pointed nails *n*. Such a nail is illustrated in Fig. 5. As will be noted, its point has two opposite broad sides and two opposite narrow sides. When being driven and clinched the clinch takes place at one or the

other of the broad sides of the nail. As illustrated in Figs. 2, 3 and 4, the nails *n* are aligned in the raceway 22 promiscuously in regard to their orientation angularly about their longitudinal axes. Thus when the separator 24 separates the lowermost nail in the raceway and permits the nail to drop into the throat 26, there is no guarantee as to the angular position of the nail about its longitudinal axis. It is however of vital importance that the nail be oriented axially to assume a predetermined position since, as explained, the nail is clinched only at the broad sides of its point. In order to orient the nails when they are being delivered to the throat 26 so as to obtain a full control over the direction of clinch, the throat has inserted in it a quill 54 which comprises a main body in the form of a right prism and a tapered lower end formed by four separately movable spring jaws of which two opposite jaws are in contact with each other and the other two opposite jaws engage the side faces or side edges of the contacting jaws. Thus, it may be said that the jaws are asymmetrically arranged. The nail, when being dropped into the quill 54, is so oriented by the quill that the broad sides of its point face the contacting jaws 56 of the quill 54, the nail being held in that position. Accordingly, the quill is so mounted in the throat 26 that the contacting jaws 56 face the line of feed. Thus, full assurance is given that the nail, when being driven and clinched, will be clinched in the line of feed. The driving of a chisel-pointed nail out of the quill 54 in proper position is illustrated in Fig. 7. It is understood that when the head of the nail and the driver pass through the passage provided by the jaws of the quill the jaws will yield apart.

Referring to Figs. 2, 3 and 4, it will be noted that the lowermost nail in the raceway 22 is arranged with the narrow sides of its point facing the line of feed indicated by arrows, the following nail is in a position in which the broad sides of its point face the line of feed and the third nail is in an in-between angular position. Regardless of the various positions angularly of their longitudinal axes the nails may assume in the raceway 22, each nail, when being dropped into the throat, if it is not already properly oriented, will be turned by the quill 54 about its longitudinal axis as soon as the nail point engages the jaws 56. Assuming that the lowermost nail in the raceway 22 is being dropped into the quill 54 and, as explained, is to be rotated 90° about its longitudinal axis in order to be properly oriented, its point will engage the contacting quill jaws 56 about midway of their heightwise extent. Since there is some play between the nail head and the nail passage in the main body of the quill 54, the nail apparently will tilt and strike with its head against one side of the nail passage in the quill, resulting in a jarring of the nail. Thus the nail point will be jarred and, due to the cam action of the contacting jaws 56 the nail will be rotated about its longitudinal axis so that it can slide down the nail guiding passage provided by the jaws 56 of the quill until the lower end of the nail is about flush with the lower ends of the jaws 56. In this position the broad sides of the nail point face the contacting jaws of the quill which in turn face the line of feed.

In view of the particular arrangement of the jaws 56 the nail passage provided between them corresponds substantially to the chisel-pointed end of the nail.

5

The operation of the above-described machine is apparent from the foregoing description but may be briefly summarized as follows. After the awl 18 has been caused to pierce the work and to impart a feeding movement thereto, it is withdrawn from the work and returned to initial position. The slide 28 carrying the throat 26 and the nail separator 24 is moved into its forward position thereby positioning the throat in the line of drive and causing the separator 24 to separate the lowermost nail in the raceway. The nail is dropped into the quill and oriented axially, if necessary, and then inserted by the descending driver into the work which is held clamped between the abutment 30 and the tip of the horn 14, the nail entering the work through the previously made awl hole. The point of the nail is clinched in the line of feed as a result of the orienting of the nail by the quill, the clinched nail point extending opposite to the direction of feed, due to the particular configuration of the clinching face provided in the tip of the horn 14. Thereafter the driver 20 is withdrawn to its uppermost position and the throat 26 and the separator 24 are retracted as a result of a rearward movement of the slide 28 in readiness for the awl 18 again to pierce the work and to impart a feed movement thereto.

Having described my invention, what I claim as new and desire to secure by Letters Patent of the United States is:

1. In a fastening inserting machine, a fastening receiving throat to which a fastening to be inserted is delivered, and a fastening rotating member associated with said throat, said member comprising a plurality of asymmetrically arranged jaws adapted to engage the fastening as

6

it is delivered and to orient it about its longitudinal axis into a predetermined position angularly with respect to said axis.

2. In a fastening inserting machine, a fastening receiving throat to which a fastening to be inserted is delivered, and a quill in the throat, the quill comprising a plurality of asymmetrically arranged yieldable jaws adapted to rotate fastenings successively presented thereto about their longitudinal axes so as to locate each fastening in the throat in the same predetermined angular position relatively to its longitudinal axis.

3. A nail box or quill adapted for use in a machine for inserting chisel-pointed nails, the quill being provided with four nail rotating spring jaws of which normally two opposite jaws are in contact with each other and the two other opposite jaws are in engagement with the side edges of the contacting jaws.

MARK E. FERNALD.

REFERENCES CITED

The following references are of record in the file of this patent:

UNITED STATES PATENTS

Number	Name	Date
376,791	Sweet -----	Jan. 26, 1888
447,398	Crawford -----	Mar. 3, 1891
502,550	Curtis -----	Aug. 1, 1893
513,820	Nye -----	Jan. 30, 1894
533,733	Nye -----	Feb. 5, 1895
603,626	Eader -----	May 10, 1898
461,853	Small -----	Oct. 27, 1891
374,549	Murray -----	Dec. 6, 1887
331,299	Hopkins -----	Dec. 1, 1885