



(12) EUROPEAN PATENT APPLICATION

(43) Date of publication:
27.09.2006 Bulletin 2006/39

(51) Int Cl.:
B65D 85/672^(2006.01) B65D 85/66^(2006.01)
B65D 19/00^(2006.01)

(21) Application number: 06005723.9

(22) Date of filing: 21.03.2006

(84) Designated Contracting States:
AT BE BG CH CY CZ DE DK EE ES FI FR GB GR
HU IE IS IT LI LT LU LV MC NL PL PT RO SE SI
SK TR
Designated Extension States:
AL BA HR MK YU

(71) Applicant: Lucy Plast S.p.A.
06026 Pietralunga (PG) (IT)

(72) Inventor: Fiorucci, Sandro
06026 Pietralunga (PG) (IT)

(74) Representative: Fisauli, Beatrice A. M.
Con Lor SPA
Via Renato Fucini, 5
20133 Milano (IT)

(30) Priority: 22.03.2005 IT MI20050472

(54) Transportation and stocking system for reels

(57) This invention relates to a reel transport and storage system suitable for packing reels of various lengths and diameters.

Said system, which receives reels wound on a pin, is of the type comprising a pair of flanges fitted with means designed to engage said pin, said flanges being support-

ed by a pallet of variable length, so that said flanges (3) can be distanced, depending on the length of the reel (4) to be housed, said flanges (3) being surmounted by a lid (20) which snap-fits onto said flanges (3), and said pallet (2), flanges (3) and lid (20) forming the first packing of said reel (4), which is designed to support the second packing of said reel (4), resting on said lid (20).

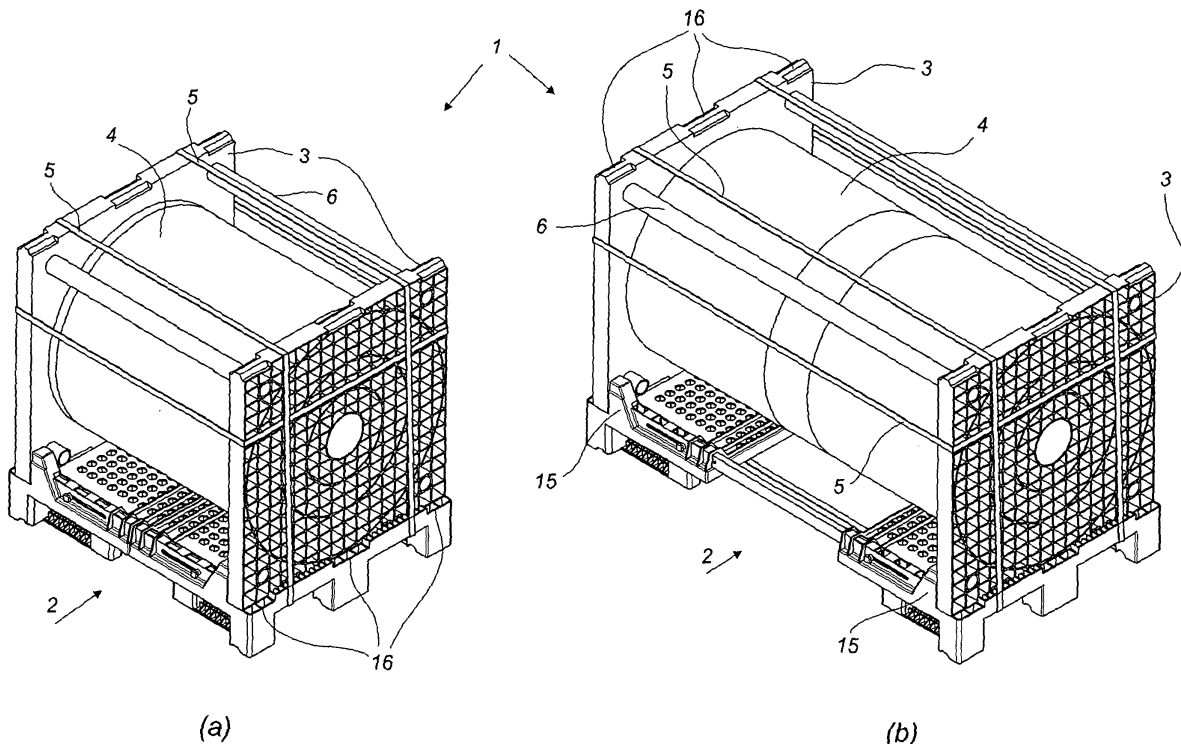

Fig. 1

Description

[0001] This invention relates to a reel transport and storage system suitable for packing reels of various lengths and diameters.

[0002] In order to store and transport reels, rudimentary tools consisting of a pair of chipboard flanges, with a hole in the middle of each flange, are generally used; a cylindrical pin inserted into the flanges connects said flanges to one another and also acts as support for the reel.

[0003] However, this solution creates practical problems for storage. Once a certain number of reels have been mounted on said flanges, it can be difficult to store them tidily and load them rationally onto vehicles.

[0004] They are usually stored horizontally, so that said flanges are vertically aligned. In order to stabilise said position, H-shaped sections bars are inserted between the edges of the flanges that face one another when they are stacked. However, said sections bars only prevent longitudinal movements of the reels; they are not very effective in preventing them from sliding sideways.

[0005] In any event it is practically impossible to stack reels of different lengths.

[0006] An improved means of transport and storage of said reels is illustrated in patent EP-A-332186, filed by Hoechst Aktiengesellschaft, which describes supports constituted by moulded plastic flanges with an approximately rectangular shape, bevelled edges and a set of stiffening ribs. Said flanges also possess a central cylindrical boss which is inserted into the hole in the pin on which said reels are wound.

[0007] Further progress is described in patent EP 0 447 737, filed by ESO-Plast/Lucy-Plast, which describes flanges made in such a way that they can be stacked on top of one another so that they can be stored in a small space when they are not in use as supports for reels, which said flanges are designed in such a way as to aid stacking of reels and securing of reels to one another, especially as regards the stability of the parts transported.

[0008] Said flanges are also very suitable for mounting on a pallet with bosses and/or recesses designed to engage corresponding recesses or bosses on said flanges, so as to obtain an assembly which, with the simultaneous cooperation of props inserted between the flanges and metal straps, is particularly solid and suitable to be handled with the usual handling gear and means of transport such as fork-lift trucks.

[0009] However, said system presents the drawback that it requires the use of pallets of a suitable length and width for each reel. In other words, to transport and/or store reels of different lengths and diameters, pallets of corresponding lengths and widths are required. This means that a large number of pallets is needed, with a consequent increase in costs and pallet storage problems.

[0010] This invention solves said problem by offering

a reel transport and storage system as claimed in claim 1, which said system comprises a pallet, a pair of flanges and various parts designed so that it can easily adapt to reels of various lengths and diameters, thus forming solid assemblies suitable to be easily conveyed and stored, with no need for a cumbersome, expensive assortment of said pallets, and allowing reels of different lengths to be stacked.

[0011] The invention comprises firstly a pallet made in two parts, or half-pallets, connected by metal bars which slide in relation to said half-pallets, which said half-pallets can be fixed to said bars in such a way that the distance between them can be regulated, so that they can act as support for reels of different lengths. Another important component of the system is a lid, which completes the packing at the top and allows reels of different lengths to be stacked. The length of said lid can be adjusted to adapt it to various situations. The invention also includes special adaptors which allow the pallet to which the invention relates to be used with flanges of various widths, the size of said flanges depending on the diameter of the reels.

[0012] The invention is completed by special configurations of the parts constituting the transport and storage system according to the invention, which allow said parts to be stacked when they are not in use.

[0013] The invention will now be described in detail according to a preferred embodiment, by way of example but not of limitation, with reference to the annexed figures, wherein:

- figures 1 (a, b) show a reel transport and storage device according to the invention;
- figure 2 shows a pallet according to the invention in the extended configuration;
- figure 3 shows a half-pallet;
- figure 4 shows a pallet according to the invention in the closed configuration;
- figure 5 shows the stacking of two reels mounted on their pallets;
- figure 6 is a view of the lower part of a pallet according to the invention which acts as support for a reel;
- figure 7 is a view of the lower part of a pallet according to the invention;
- figure 8 shows two stacked pallets in the closed configuration;
- figures 9 (a, b) shows a lid designed to be fitted above the packing;
- figure 10 shows the stacking of a number of reels of different lengths;
- figures 11 (a, b) show two views of the stacking of a number of lids on a pallet;
- figure 12 shows two stacked pallets in accordance with a first variation;
- figure 13 shows the assembly of a reel support flange, said flange having a smaller width than the pallet;
- figure 14 shows some flanges stacked and deposited

on a pallet according to the invention;

- figure 15 shows a pallet in accordance with a second variation, in the closed configuration;
- figure 16 shows the pallet in accordance with said second variation, with a reel mounted on it;
- figures 17 (a, b) show the pallet in accordance with the second variation, in the closed and extended configuration, with the cradles inserted.

[0014] In fig. 1, no. (1) indicates a reel transport and storage device according to the invention. Said device (1) comprises a pallet of adjustable length (2) fitted with a pair of flanges (3) which act as support for a reel (4). Said reel, flanges and pallet are held together with metal or plastic straps (5), possibly with the insertion of struts (6) between said flanges (3).

[0015] Said pallet (2) (fig. 2) comprises two half-pallets (2a) and (2b), preferably connected by at least one pair of bars (7) and (8). Said bars (7) and (8) are inserted slidingly into cavities (7a) and (8a) in half-pallet (2a), and (7b) and (8b) in half-pallet (2b). Said cavities are more clearly visible in fig. 3.

[0016] If said bars (7) and (8) are suitably slid into said cavities (7a), (7b), (8a) and (8b), the distance between the two half-pallets (2a) and (2b) can be regulated in such a way that reels of different lengths can be accommodated. Said bars will be advantageously graduated so that the length of the pallet can be regulated even if the reel is not present.

[0017] When the distance between the two half-pallets has been regulated, bars (7) and (8) can be secured to said half-pallets, fixing means being provided such as a screw (10) with a knob which is inserted into a slot (11) in one side of said cavities (7a), (7b), (8a) and (8b), and screwed to said bars (7) and (8), clamping said bars (7) and (8) against said cavities (7a), (7b), (8a) and (8b) and preventing their reciprocal movement.

[0018] Said screw (10), by interacting with said cavities (7a), (7b), (8a), (8b), also acts as stop means to prevent said bars from being pulled out of said cavities.

[0019] To increase the stability of the assembly, it is preferable to use a third bar (9) which is inserted into corresponding cavities (9a) and (9b) in half-pallets (2a) and (2b).

[0020] Moreover, to increase the flexural rigidity of the assembly and simultaneously reduce its lateral dimensions, said bars (7) and (8) will preferably have a rectangular cross-section with the longer side of said cross-section placed vertically, and central bar (9) will also have a rectangular cross-section, but with the longer side positioned horizontally.

[0021] Said pallet (2) is also fitted with a plurality of feet (12) at each end of the pallet, and feet (13) in the intermediate area, together with anti-overtipping parts (14) which form tunnel unions, thus making transport with forklift trucks safer, and forcing them to grip the pack towards its centre of gravity. Two tunnel unions are shown in the half-pallet illustrated in fig. 3, but to increase

the safety of transport, three of said tunnel unions could be fitted.

[0022] Fig. 4 shows a pallet (2) according to the invention, in the closed configuration.

5 **[0023]** Figs. 5 (a, b) show two views of two reels (4) stacked with the transport and storage device according to the invention.

[0024] To mount reel (4) on pallet (2), said flanges (3) are laid on said pallet (2), causing them to come to rest against bosses or abutments (15) on said pallet (2). To aid assembly and increase the stability of the assembly, said flanges (3) have parts (16) (fig. 6) at their upper and lower edges which are shaped so that they can be inserted into seatings (17) (fig. 2) in the pallet. Moreover, to aid stacking of the reels, feet (12) of pallet (2) contain seatings (18) (figs. 6 and 7) into which the shaped parts (16) of the upper edge of flanges (3) are inserted. The assembly is shown in fig. 5a, which demonstrates in detail how a shaped part (16) of flange (3) is inserted into seating (18) of a foot (12) of upper pallet (2).

[0025] When the pallets are not in use, they can easily be stacked, snap-fitting means which prevent their reciprocal movement being fitted to facilitate handling and transport. As shown in fig. 8, feet (12) at the four corners of the upper pallet rest against said abutments (15) formed by the lower pallet; this prevents reciprocal sliding in a longitudinal direction. To prevent reciprocal sliding in the transverse direction, bosses (19) which act on the sides of feet (12) are fitted.

30 **[0026]** A preferred embodiment of the invention described involves the use of a lid or base (20), also adjustable (fig. 9), which constitutes the support base for stacking shorter reels (fig. 10).

[0027] Said lid (20) consists of two half-lids (20a, 20b) preferably connected by a pair of bars (21 a, 21 b), which are preferably graduated. The ends of said lid are shaped to form a seating (22), designed to engage the upper part of flanges (3), and seatings (23) designed to receive straps (24), which will preferably be used to improve the stability of the assembly.

[0028] In this way it will be possible to stack reels of different lengths, as shown in fig. 10.

[0029] Movable stop means (25) (fig. 9) can be advantageously used to prevent a pack from sliding longitudinally in relation to the pack below it. Said stop means are fitted with coupling pins (26) designed to be secured to said lid (20) simply by inserting said pins (26) into suitable holes (27) in lid (20).

[0030] Said stop means (25), positioned in suitable holes, constitute abutments against which feet (12) of the lower pallet come to rest.

[0031] In order to store and transport said lids independently of the reels, the lower part of said lids contains parts (28) (fig. 11 b) shaped so as to rest on abutments (15) of pallets (2), thus preventing any reciprocal movement. In practice, the lid rests on the top of abutment (15), which supports its weight, while said part (28) surrounds said abutment to prevent reciprocal sliding. Fig.

7 shows the coupling between said part (28) and said abutment (15).

[0032] In order to stack a number of lids (20), the lower part of the lids contains a tooth (29) (fig. 11 a) which is inserted into a seating (30) in the upper part of said lid (20), thus preventing a lid from sliding in relation to the one above it.

[0033] According to a first preferred variation (40), said pallets (2) are advantageously fitted with a part (31), the central part of which is shaped like a cradle (fig. 12). In this way, if the reel has a diameter such that it can lie on the base as a result of jolts caused by transport, damage to the surface of the reel will be prevented. For the same reasons, the lower part of lid (20) can also be advantageously equipped with a cradle (32).

[0034] If the width of flanges (3) is shorter than that of pallet (2), for example in the case of packing of reels with a smaller diameter, four movable stop means (33) will be mounted on pallet (2) close to abutments (15), against which said flanges (3) of smaller dimensions will come to rest. To allow the use of flanges of different widths, said stop means can be moved into various positions, rapid coupling means being provided, such as pins which are inserted into holes in the base of pallet (2). Fig. 13 shows a half-pallet (2b) with a flange (3), whose width is less than that of half-pallet (2b), which rests on said mobile stop means (33).

[0035] Fig. 14 shows some flanges (3) stacked on a pallet (2) for the purpose of storage and transport. For this purpose there are recesses (34) in the four corners of said flange (3) into which the upper parts of abutments (15) are inserted, while the flanges are secured to one another with cylinders (35) which are inserted into corresponding cylindrical holes (36) in the top flange.

[0036] Narrower flanges can be housed on said mobile stop means (33) positioned at a suitable reciprocal distance.

[0037] The reel transport and storage system according to the invention, as described above, requires the use of flanges (3) having shaped parts (16) which are inserted into seatings (17) in pallet (2). However, reels already packed with flanges of a different type, which do not have shaped parts (16), or are made of wood, may have to be mounted on the pallet.

[0038] At other times the reels may be particularly short, so that abutments (15), against which flanges (3) come to rest, prevent the correct positioning of the reels, thus in practice preventing packing.

[0039] Fig. 15 shows a second variation (41) on pallet (2), which is designed to increase the versatility of use of said pallet by eliminating the drawbacks referred to above.

[0040] Said pallet (41) comprises two parts (41 a) and (41 b), and the distance between said parts can be varied according to the length of the reel to be transported.

[0041] In said variation, the upper part of pallet (41) is substantially smooth, and is fitted with four rubber-clad plates (42) in order to exert a degree of friction with a pair

of flanges (3a) (fig. 16) which, due to the friction with plates (42), remain in position even if they do not come to rest against abutments (15) and are not inserted into seatings (17), although they are obviously secured by straps (5).

[0042] The upper part of pallet (41) shown in fig. 15 is completely smooth. However, once again bosses (19) can be fitted, as in the case of pallets (2) and (40), shown in figs. 16 and 17, which facilitate stacking of the pallets, without reducing the versatility of pallet (41). For this purpose, in the case of second variation (41) on pallet (2), it is again preferable for seatings (18) in the lower part of feet (12) to receive the upper parts of flanges (3, 3a) of the packing beneath. As the upper parts of flanges (3a) may be of any type, it is advisable to make seatings (18) wide enough to accommodate flanges (3a) of all types.

[0043] If the reel is shorter than the one shown in fig. 16, flanges (3a) could obviously also be moved towards the centre of pallet (41) and remain in position due to the effect of the friction exerted by contact between flanges (3a) and rubber-clad plates (42), said flanges (3a) being pressed against said plates (42) by metal or plastic straps (5).

[0044] To further increase the versatility of pallet (41), cradles (43), provided as accessories to the pallet, can be fitted if necessary merely by inserting the pins present in the lower part of the cradles into seatings (44) in pallet (41).

[0045] In fig. 15 there are six of said seatings (44) for each of the two half-pallets (41 a, 41 b), said seatings being arranged in two rows of three. With this arrangement of seatings (44), if there are four pins to each cradle (43), the cradles can be positioned either towards the interior of the pallet, or towards the ends. The position of the cradles will be chosen on the basis of the type of reels, in order to increase their protection.

[0046] If it is decided not to use the cradles, they can easily be removed and the reel will be replaced with the flanges alone.

[0047] Various combinations of the solutions described are obviously possible. For example, movable stop means (33) could also be fitted to the first and second variation (40, 41) of pallet (2). One skilled in the art would have no difficulty in finding the most suitable combination for each specific case.

[0048] The embodiments described are some preferred embodiments of the reel transport and storage device according to the invention, provided by way of example but not of limitation. One skilled in the art could devise numerous other embodiments, all of which fall into the ambit of protection of the following claims.

[0049] For example, flanges (3) with a different design from the one indicated in the above description could be used. In such case the seatings into which said flanges are inserted could advantageously be adapted to the shape of the flanges, either by modifying their design or by using adaptors, namely parts with a shape that en-

gages simultaneously with the pallet and flanges.

Claims

1. Transport and storage system of reels wound on a pin, of the type comprising a pair of flanges fitted with means designed to engage said pin, which said flanges are supported by a pallet, **characterised in that** said pallet (2) which receives said flanges (3) is of variable length, so that it can distance said flanges (3), depending on the length of reel (4) to be received, and which said pallet (2) comprises a pair of half-pallets (2a) and (2b) and means designed to regulate the distance between said two half-pallets (2a) and (2b) and secure them at the required distance. 5
2. Transport and storage system as claimed in claim 1, **characterised in that** it includes two semi-pallets (2a) and (2b), which slide along one or more connecting bars, which said bar is inserted into cavities in said semi-pallets so as to regulate their reciprocal distance, means designed to secure said bar to said semi-pallets being provided. 10
3. Transport and storage system as claimed in claim 2, **characterised in that** it includes the use of a pair of bars (7) and (8), which are inserted into cavities (7a) and (8a) in said pallet (2a), and cavities (7b) and (8b) in said pallet (2b). 15
4. Transport and storage system as claimed in claim 2, **characterised in that** it includes the use of three bars (7), (8) and (9) which are inserted into cavities (7a), (8a) and (9a) in said half-pallet (2a), and cavities (7b), (8b) and (9b) in said half-pallet (2b). 20
5. Transport and storage system as claimed in claims 2 to 4, **characterised in that** said bars (7), (8) and (9) are graduated to allow easy regulation of the length of said pallet (2). 25
6. Transport and storage system as claimed in any of claims 1 to 5, **characterised in that** said means designed to secure said half-pallets (2a) and (2b) to said bars (7), (8) and (9) comprise screws (10) which are screwed to said bars (7), (8) and (9) and tightened against part of said half-pallets (2a), (2b). 30
7. Transport and storage system as claimed in claim 6, **characterised in that** said means designed to secure said half-pallets (2a) and (2b) to said bars (7), (8) and (9) are designed to act as stop means for said bars, to prevent said bars (7), (8) and (9) from being pulled out of the cavities in which they are inserted. 35
8. Transport and storage system as claimed in at least one of claims 1 to 7, **characterised in that** it includes bosses or abutments (15) in the upper part of said pallet (2), against which said flanges (3) rest when said flanges (3) are fitted to support a reel (4). 40
9. Transport and storage system as claimed in at least one of claims 1 to 8, **characterised in that** it includes a first variation (40) on said pallet (2), having a part (31) shaped like a cradle to prevent damage to the surface of reel (4) if said reel (4) is of such diameter that it may come to lie on said pallet (40) as a result of jolts during transport. 45
10. Transport and storage system as claimed in at least one of claims 1 to 9, **characterised in that** it includes seatings (17) in the upper part of said pallet (2, 40) into which shaped parts (16) of said flanges (3) are inserted, when said flanges (3) are mounted on said pallet (2, 40) to support a reel (4). 50
11. Transport and storage system as claimed in at least one of claims 1 to 10, **characterised in that** said flanges (3) present parts (16) at their upper and lower edges which are shaped in such a way that they can be inserted into seatings (17) in pallet (2, 40). 55
12. Transport and storage system as claimed in at least one of claims 1 to 7, **characterised in that** it includes a second variation (41) on said pallet (2) which is substantially smooth in the upper part and fitted with rubber-clad plates (42), which are suitable to secure flanges (3a) of any type by friction. 55
13. Transport and storage system as claimed in at least one of claims 1 to 12, **characterised in that** it includes movable stop means (33) which can be fitted and secured in a number of determined positions in the upper part of said pallet (2, 40, 41), against which said flanges (3, 3a) come to rest. 55
14. Transport and storage system as claimed in at least one of claims 1 to 13, **characterised in that** the lower part of said pallet (2) is fitted with a plurality of feet (12), located at each end of said pallets (2, 40, 41), and feet (13) located in the intermediate area of said pallet (2), and with parts designed to prevent the pallet from overturning (14). 55
15. Transport and storage system as claimed in claim 14, **characterised in that** said feet (12) of pallet (2, 40, 41) contain seatings (18) into which said shaped parts (16) of the upper edge of said flanges (3, 3a) are inserted when said pallet (2, 40, 41) is rested on said flanges (3, 3a) to stack said reels (4). 55
16. Transport and storage system as claimed in at least one of claims 1 to 15, **characterised in that** it includes means designed to snap-fit onto a first pallet 55

- (2, 40, 41) and a second pallet (2, 40, 41) above it, preventing their reciprocal movement and allowing a number of pallets (2) to be stacked.
17. Transport and storage system as claimed in claim 16, **characterised in that** said means designed to allow the stacking of a number of pallets (2, 40), preventing their reciprocal movement, include projecting parts (15) formed in the part upper of said pallet (2); against which said feet (12) of the pallet above come to rest to prevent reciprocal longitudinal movements.
18. Transport and storage system as claimed in claim 16, **characterised in that** said means designed to allow the stacking of a number of pallets (2, 40, 41) include projecting parts (19) formed in the upper part of said pallet (2, 40, 41), against which said feet (12) of the pallet above come to rest to prevent reciprocal transverse movements.
19. Transport and storage system as claimed in at least one of claims 1 to 18, **characterised in that** it includes a lid (20) with adjustable length so that it can rest on said flanges (3, 3a), located at different distances depending on the length of reel (4) to be received, that said lid (20) comprises a pair of half-lids (20a, 20b), and that means designed to regulate the distance between said two half-lids (20a, 20b) and secure them at the required distance are provided.
20. Transport and storage system as claimed in claim 19, **characterised in that** it includes two half-lids (20a, 20b), connected by at least one bar which slides in relation to said half-lids and is inserted into cavities in said half-lids so as to regulate the reciprocal distance.
21. Transport and storage system as claimed in claim 19, **characterised in that** it includes the use of a pair of bars (21a, 21b) which are inserted into cavities in said half-lids (20a, 20b).
22. Transport and storage system as claimed in at least one of claims 19 to 21, **characterised in that** it includes seatings (22) in said half-lids (20a), (20b) which are designed to engage the upper edges of a pair of flanges (3, 3a), mounted on a pallet (2, 40, 41) to support a reel (4).
23. Transport and storage system as claimed in at least one of claims 19 to 22, **characterised in that** it includes seatings (23) in said half-lids (20a, 20b) which are designed to receive straps for the packing of said reel (4).
24. Transport and storage system as claimed in at least one of claims 19 to 23, **characterised in that** it includes movable stop means (25) which can be secured in various positions on said lid (20), and that feet (12) of a pallet (2, 40, 41), which rests on said lid (20) when a number of packed reels are stacked, come to rest against said lid (20).
25. Transport and storage system as claimed in at least one of claims 19 to 24, **characterised in that** it includes parts (28) of said lid (20) shaped so as to rest on abutments (15) of pallets (2, 40), surrounding said abutments (15) so as to prevent reciprocal sliding.
26. Transport and storage system as claimed in at least one of claims 19 to 25, **characterised in that** the lower part of said lid (20) presents at least one tooth (29) which is inserted into a seating (30) in the upper part of said lid (20), thus preventing any sliding between one lid and the lid above it.
27. Transport and storage system as claimed in at least one of claims 19 to 26, **characterised in that** the central part of said lid (20) is fitted with a cradle-shaped part (32) in order to prevent damage to the surface of reel (4) if said reel (4) is of such diameter as to touch said lid (20) as a result of jolts during transport.
28. Transport and storage system as claimed in at least one of claims 19 to 27, **characterised in that** the four corners of said flange (3) present recesses (34) into which the upper parts of abutments (15) are inserted, to prevent said flange (3) from sliding sideways in relation to said pallet (2) when said flange (3) is rested on said pallet (2) for transport purposes.
29. Transport and storage system as claimed in at least one of claims 19 to 28, **characterised in that** the four corners of said flange (3) present projecting parts (35) which are inserted into corresponding holes (36) in upper flange (3).
30. Transport and storage system as claimed in claim 13, **characterised in that** it includes cradles (43) suitable to be fitted to said second variation (41) on said pallet (2).
31. Transport and storage system as claimed in claim 30, **characterised in that** said cradles (43) are fitted to said second variation (41) on said pallet (2) by means of pins integral with said cradles (43), which are inserted into seatings (44) in said second variation (41) on said pallet (2).
32. Transport and storage system of reels wound on a pin, of the type comprising a pair of flanges (3, 3a) fitted with means designed to engage said pin, which said flanges are supported by a pallet, **characterised in that** it includes a pallet (2, 40, 41) of variable

length which receives said flanges (3, 3a), so that it can distance said flanges (3, 3a), depending on the length of reel (4) to be received, which said flanges (3, 3a) are surmounted by a lid (20) which snap-fits onto said flanges (3, 3a), said pallets (2), flanges (3, 3a) and lid (20) forming a first packing of said reel (4), which is suitable to support a second packing of said reel (4) which rests on said lid (20).

5

10

15

20

25

30

35

40

45

50

55

7

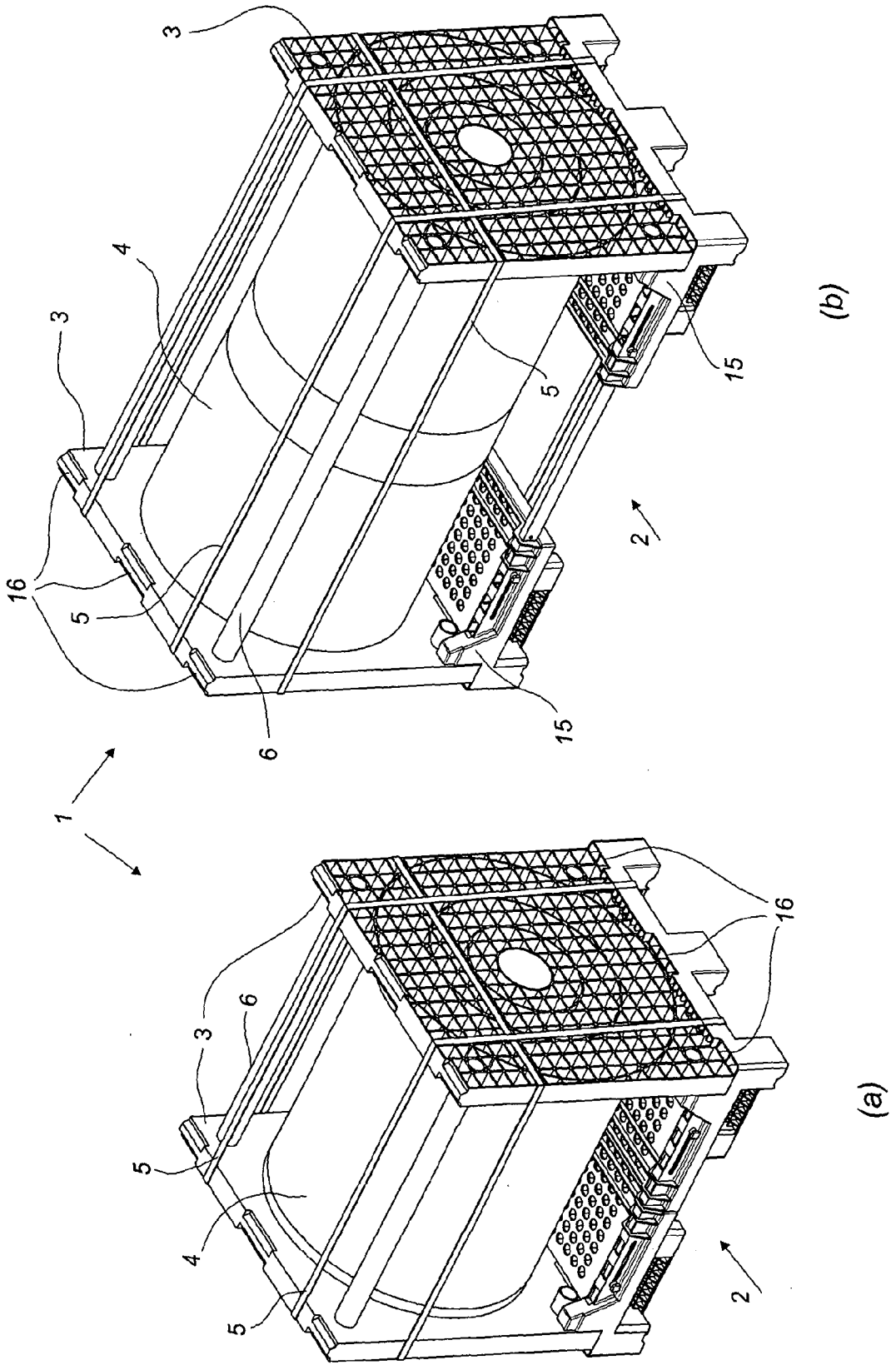

Fig. 1

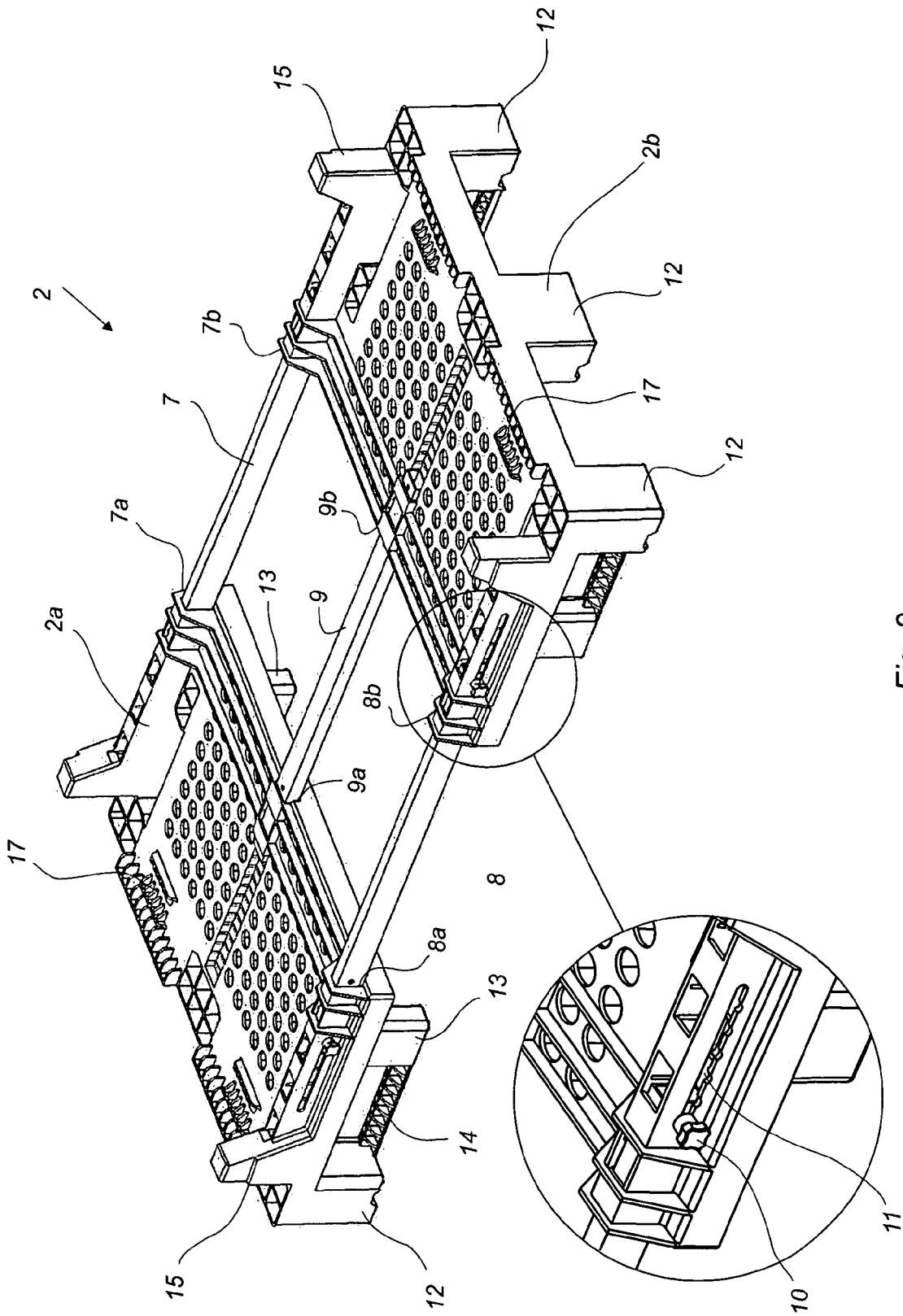

Fig. 2

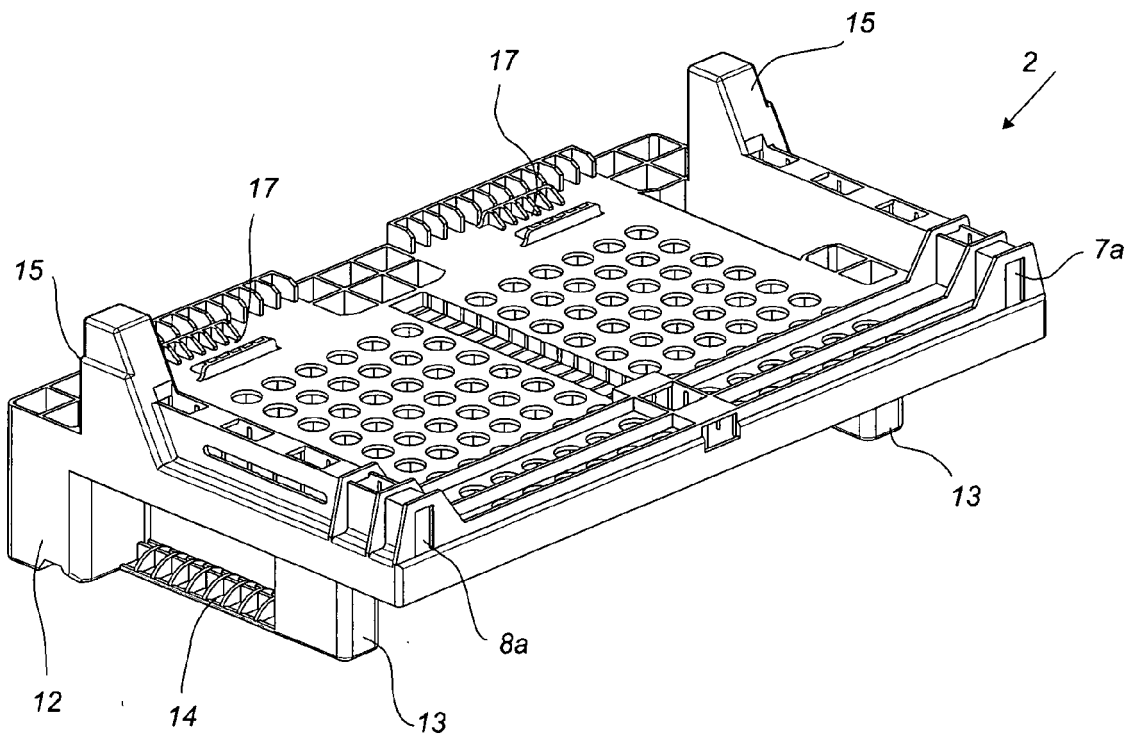

Fig. 3

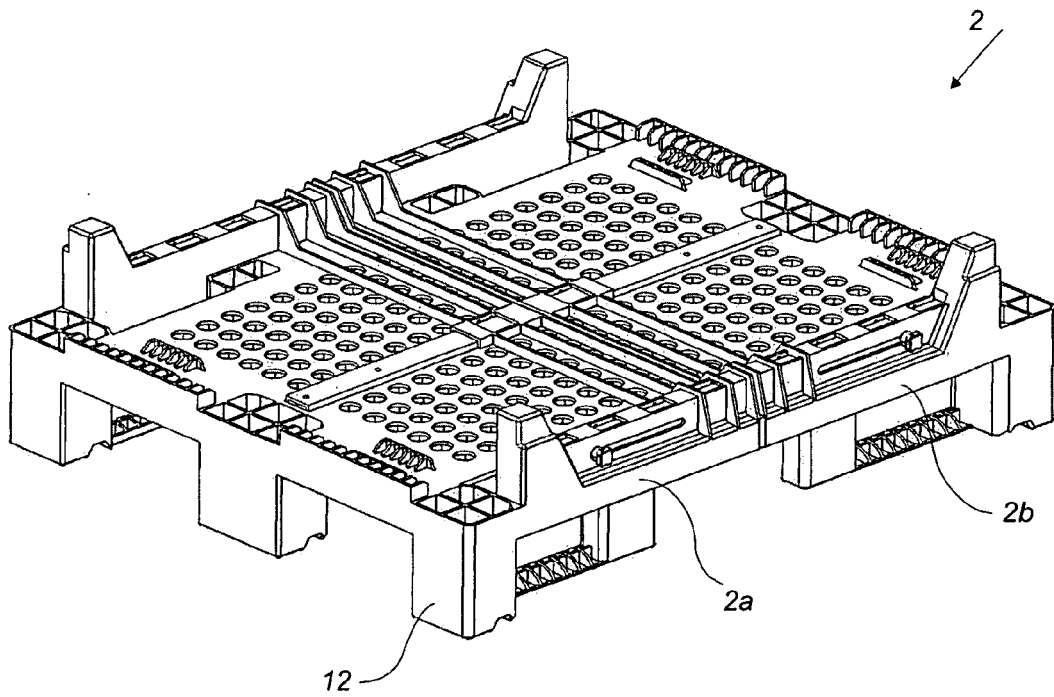

Fig. 4

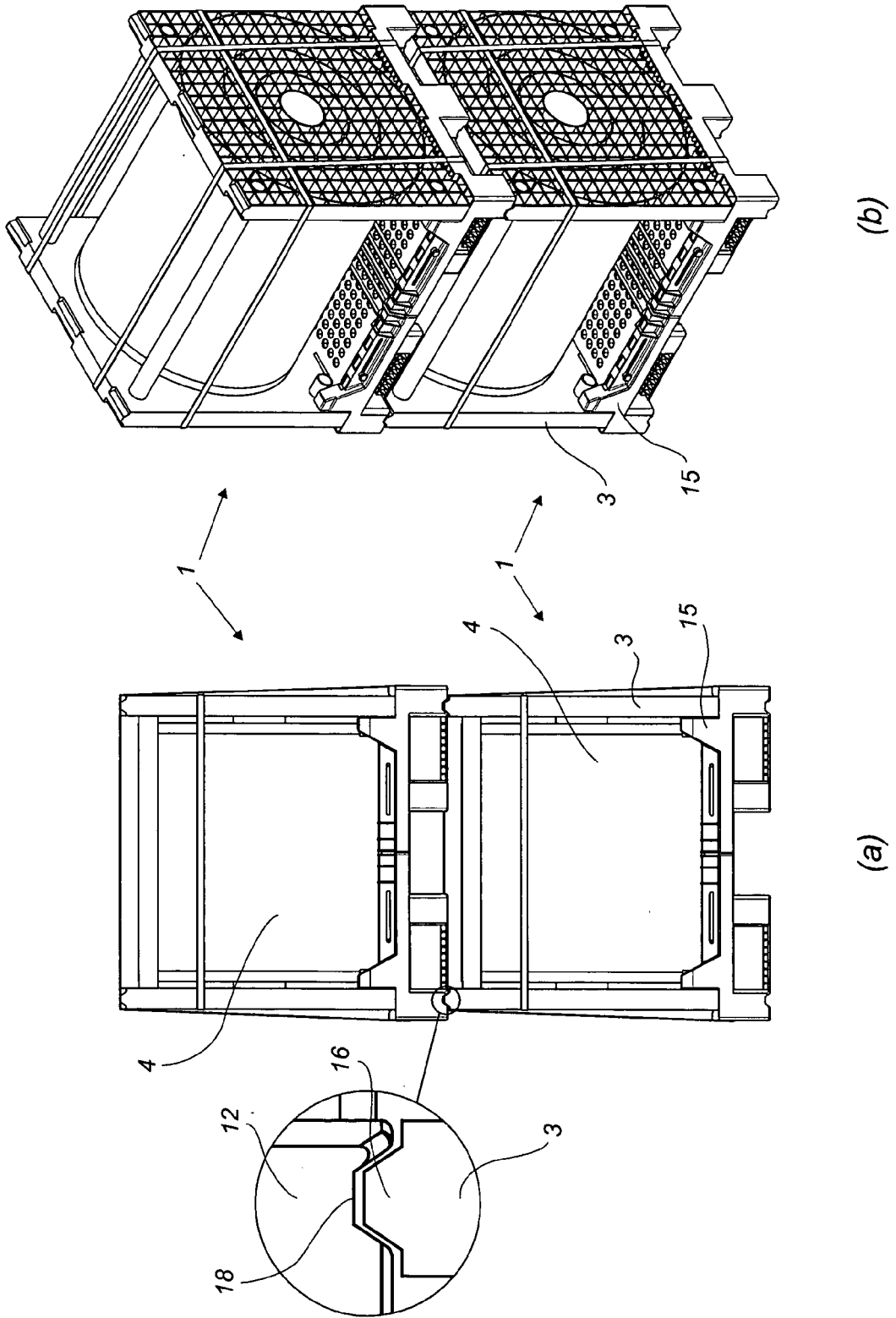

Fig. 5

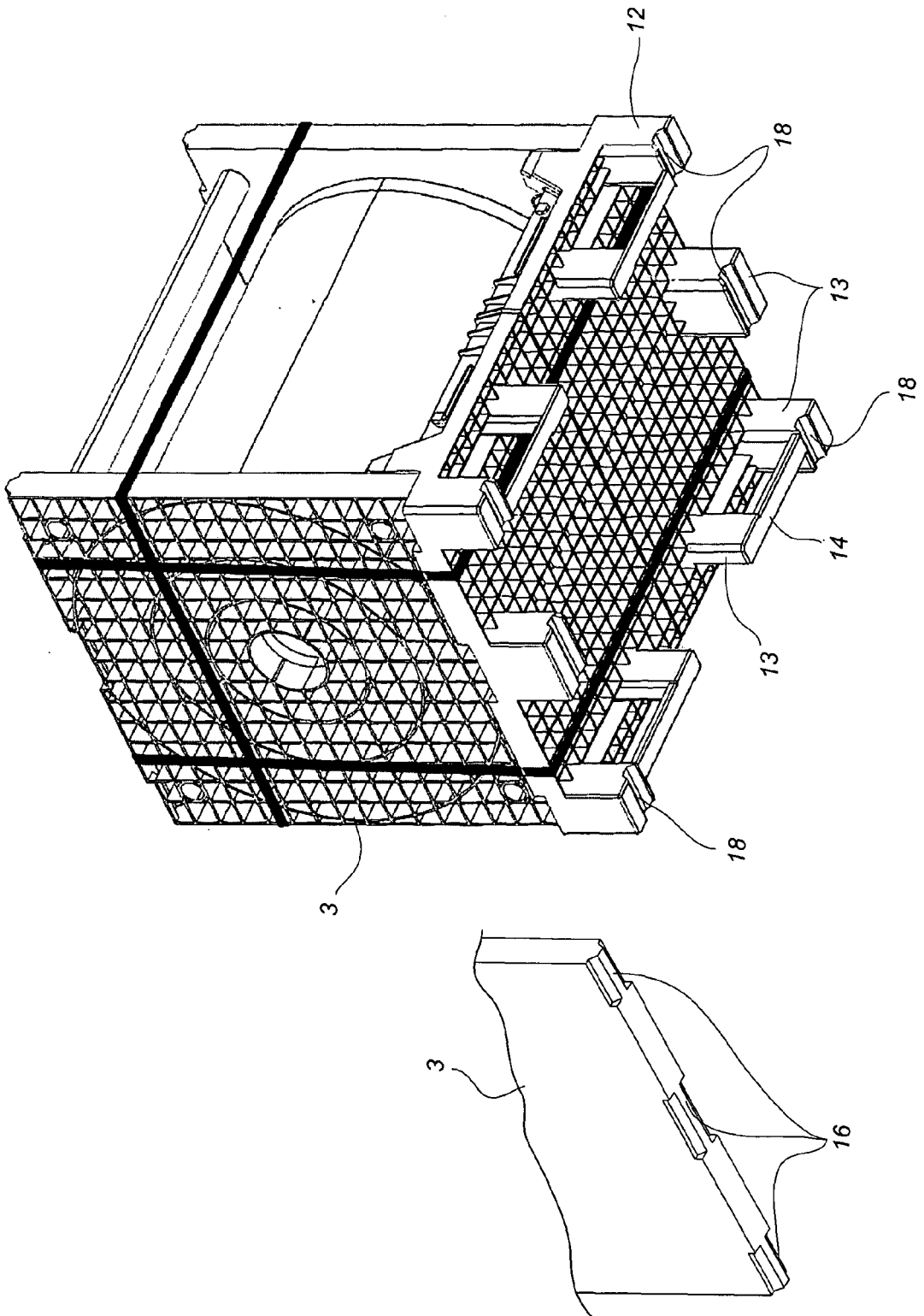

Fig. 6

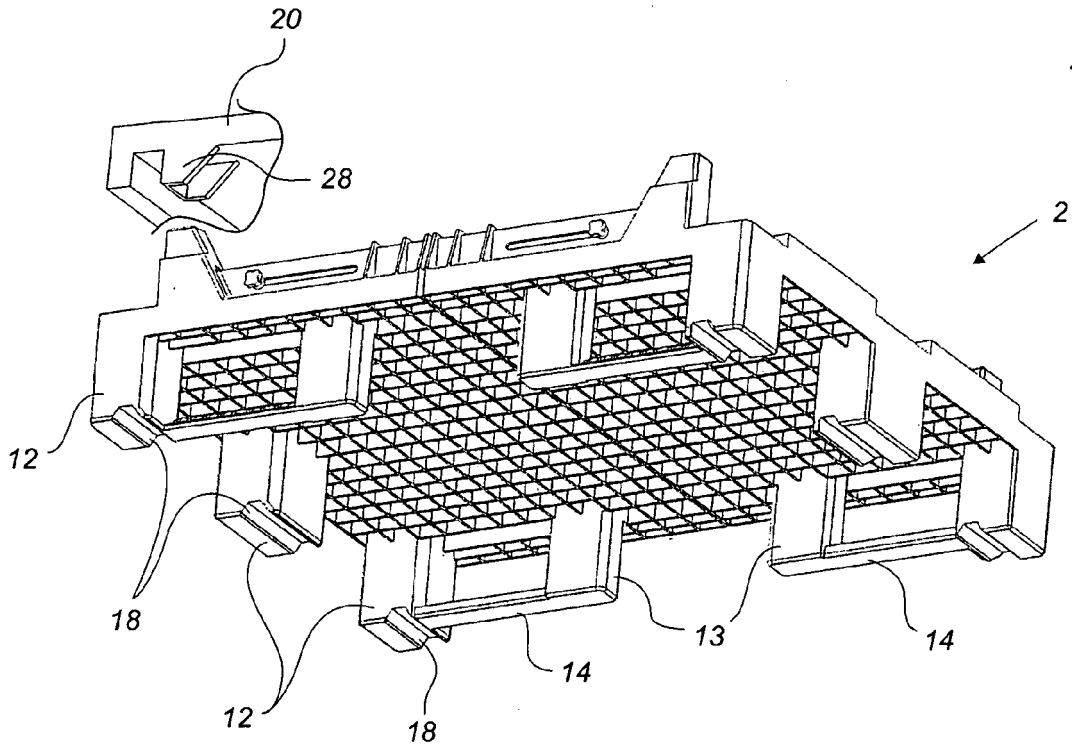

Fig. 7

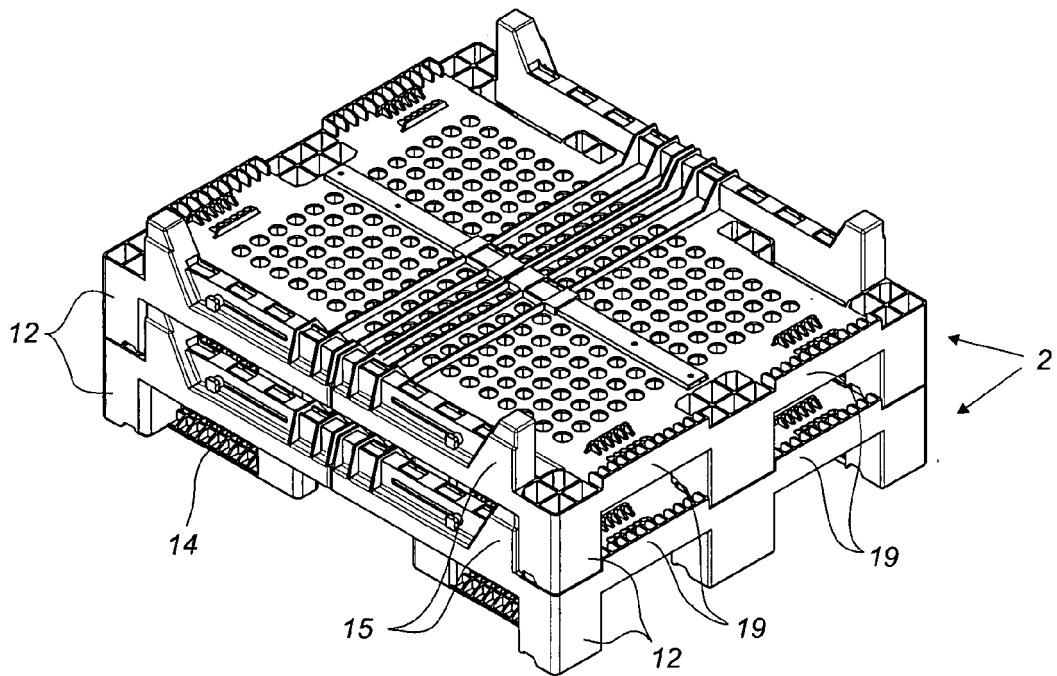

Fig. 8

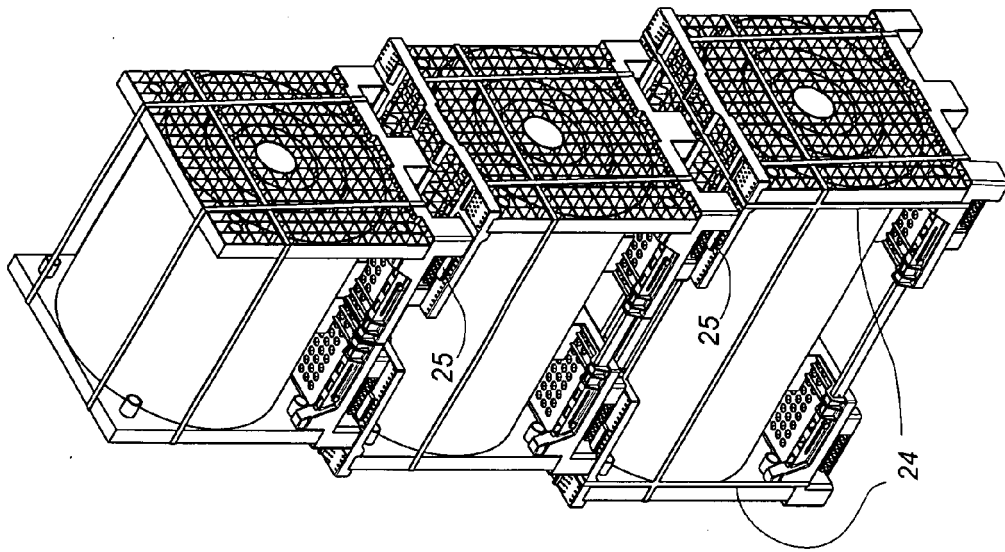

Fig. 10

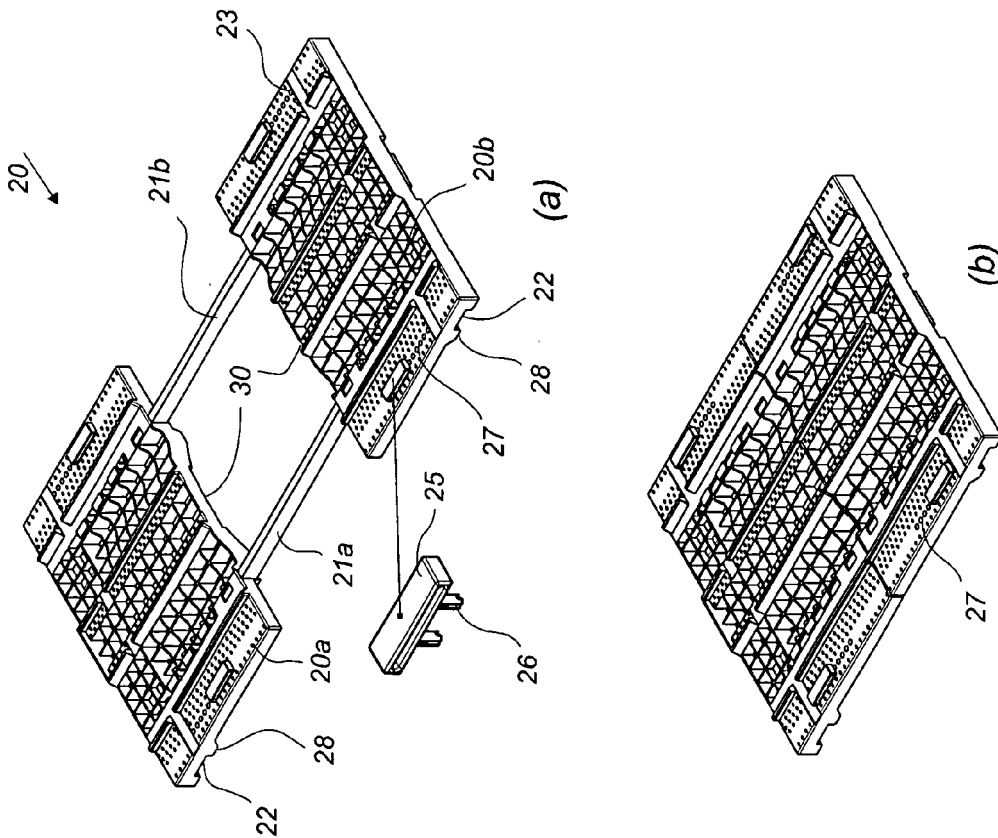

Fig. 9

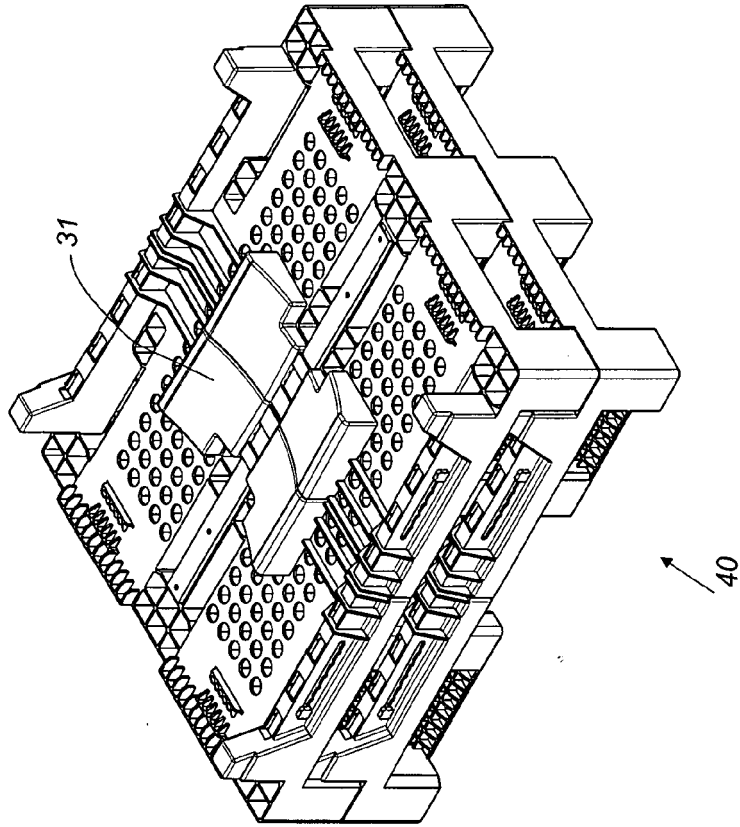

Fig. 12

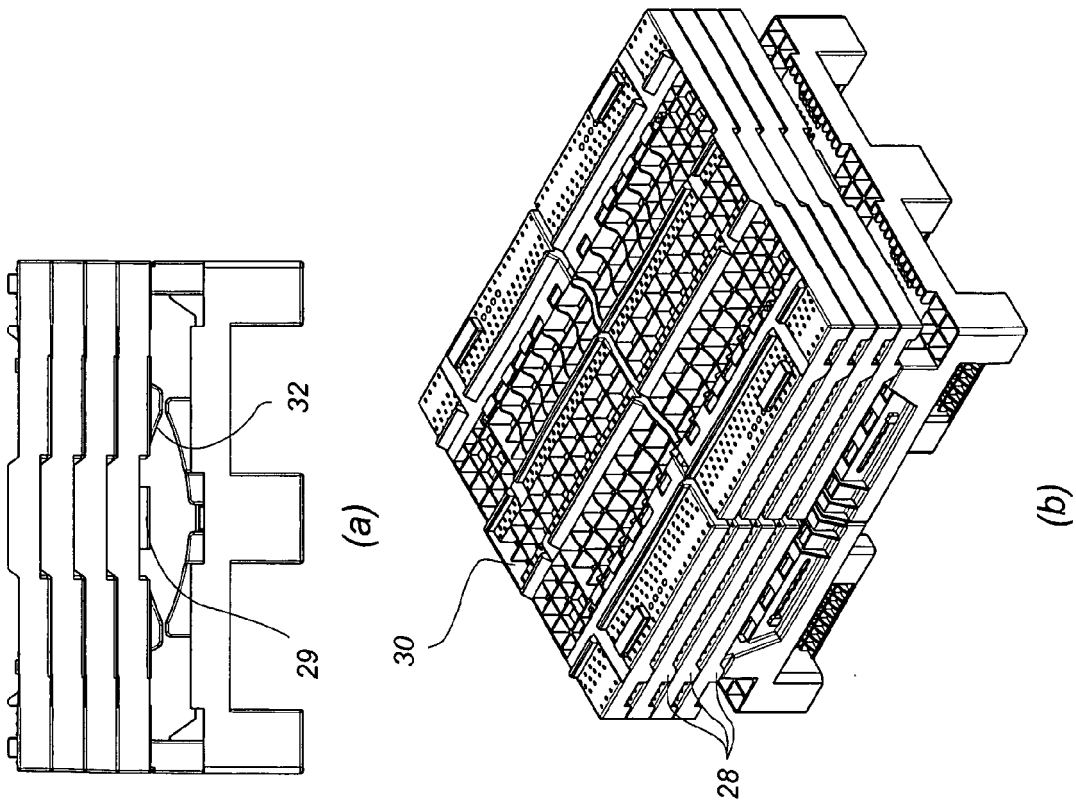

Fig. 11

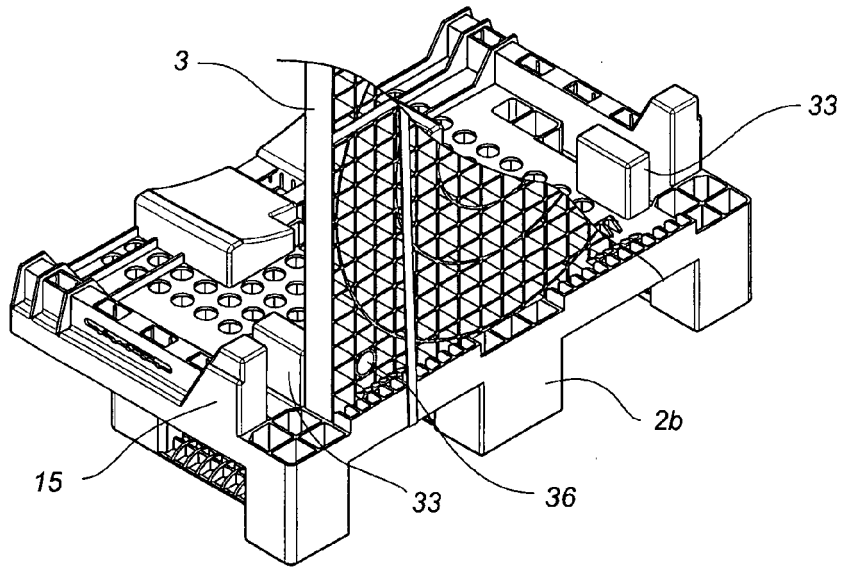

Fig. 13

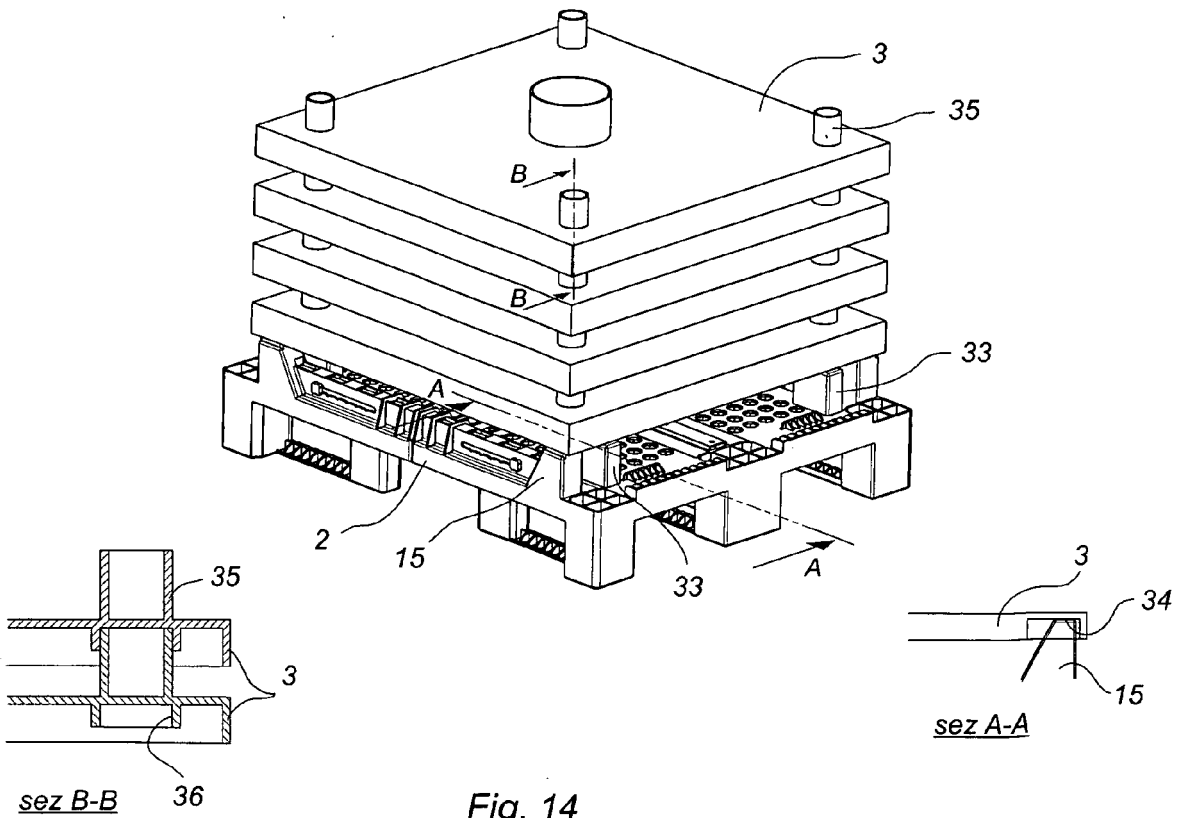

Fig. 14

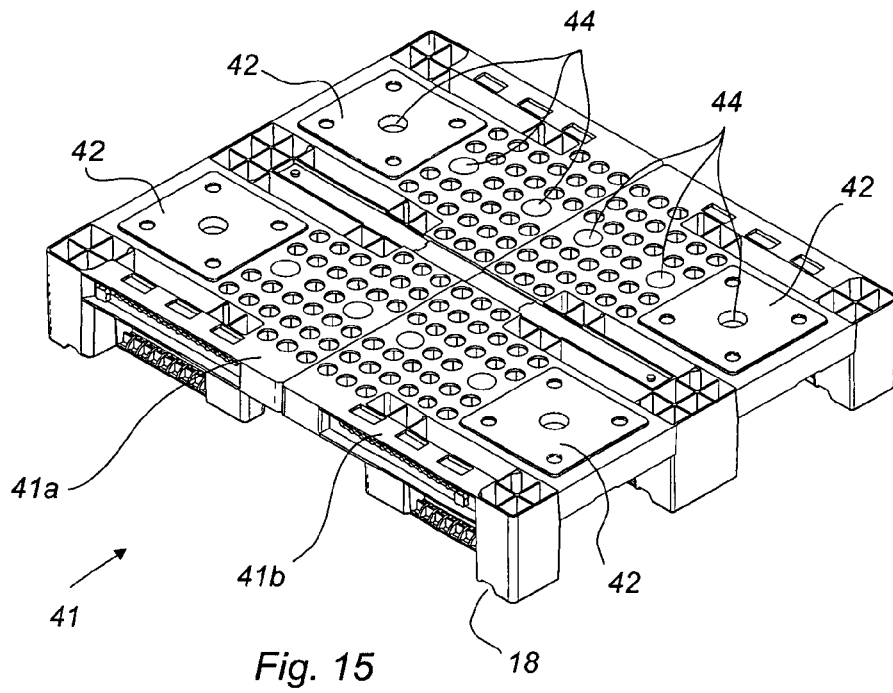

Fig. 15

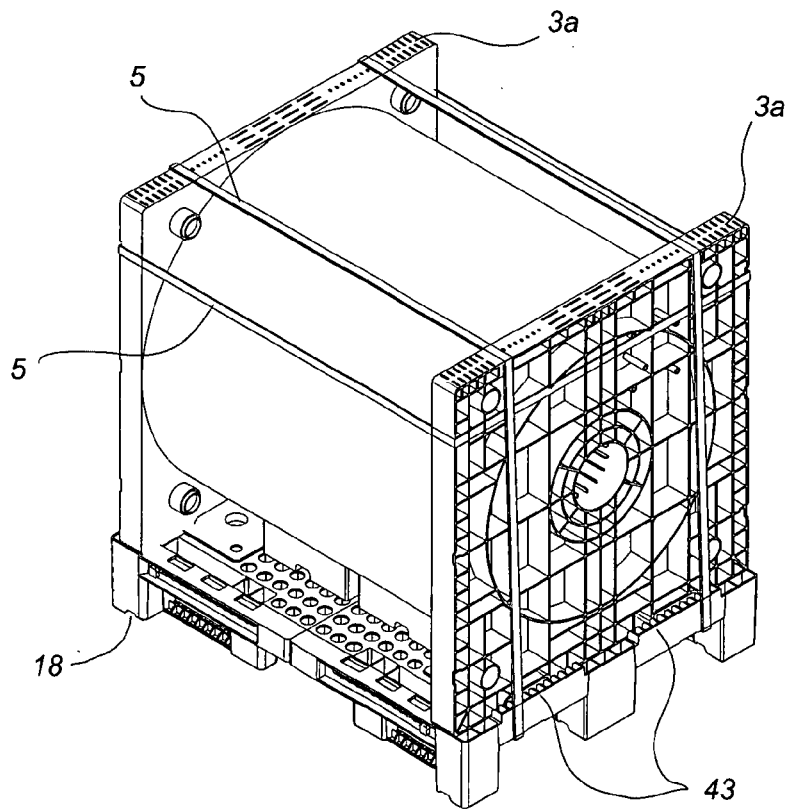

Fig. 16

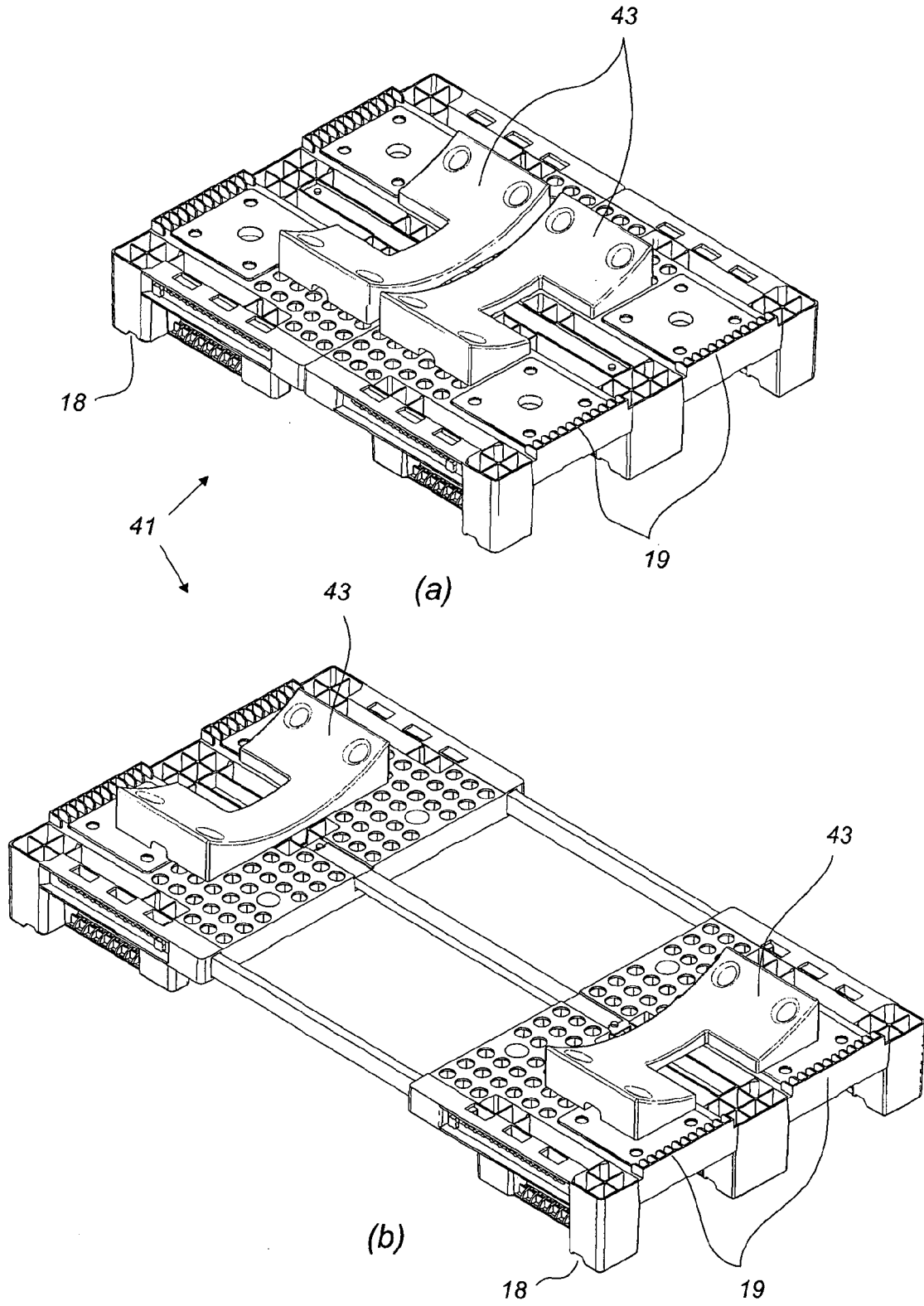

Fig. 17

REFERENCES CITED IN THE DESCRIPTION

This list of references cited by the applicant is for the reader's convenience only. It does not form part of the European patent document. Even though great care has been taken in compiling the references, errors or omissions cannot be excluded and the EPO disclaims all liability in this regard.

Patent documents cited in the description

- EP 332186 A [0006]
- EP 0447737 A [0007]