

(19)



Europäisches Patentamt

European Patent Office

Office européen des brevets



(11)

EP 0 597 628 B1

(12)

EUROPEAN PATENT SPECIFICATION

(45) Date of publication and mention
of the grant of the patent:
03.04.1996 Bulletin 1996/14

(51) Int. Cl.⁶: **B41J 2/175**, B41J 2/195

(21) Application number: **93308818.9**

(22) Date of filing: **04.11.1993**

(54) Ink replenishment system for a continuous ink jet printer

Tintenwiederauffüllungsvorrichtung für kontinuierlich arbeitenden Tintenstrahldrucker

Système de réapprovisionnement en encre dans une imprimante par jet d'encre continu

(84) Designated Contracting States:
DE FR GB

(30) Priority: **10.11.1992 US 975495**

(43) Date of publication of application:
18.05.1994 Bulletin 1994/20

(73) Proprietor: **SCITEX DIGITAL PRINTING, Inc.**
Dayton, Ohio 45420-4099 (US)

(72) Inventors:
• **Loyd, John C.**
Ohio 45458 (US)
• **Ralston, James C.**
Spring Valley, Ohio 45370 (US)

(74) Representative: **Hillier, Peter et al**
Reginald W. Barker & Co.,
Chancery House,
53-64, Chancery Lane
London, WC2A 1QU (GB)

(56) References cited:
DE-A- 3 043 260 **US-A- 3 715 219**
US-A- 4 121 222

- **PATENT ABSTRACTS OF JAPAN vol. 9, no. 87 (M-372) (1810) 17 April 1985 & JP-A-59 214 656 (SANYO DENKI K.K.) 4 December 1984**

EP 0 597 628 B1

Note: Within nine months from the publication of the mention of the grant of the European patent, any person may give notice to the European Patent Office of opposition to the European patent granted. Notice of opposition shall be filed in a written reasoned statement. It shall not be deemed to have been filed until the opposition fee has been paid. (Art. 99(1) European Patent Convention).

Description

Field of the Invention

The present invention relates to apparatus and methods for replenishing ink in a continuous ink jet printer.

Background of the Invention

In a continuous ink jet printing system, conductive ink which includes a carrier fluid such as water or an organic solvent and a colorant, such as a dye or pigment is continuously recirculated through the system to a print head. The print head generates a plurality of ink drops which are selectively charged and deflected such that some of the drops fall on a print receiving medium and some of the drops are caught and recirculated. Due to evaporation of the carrier fluid during such recirculation, the colorant concentration in the recirculating ink may increase. It is desirable for proper operation of the ink jet printing system to maintain the colorant concentration in the ink to a desired predetermined range. When printing rates are high, there is very little evaporation of carrier fluid from the ink and the ink concentration can be maintained simply by adding ink from a supplemental ink supply. Alternatively, when the printing rates are low or when the printer is in an idle state with all of the ink recirculating, the evaporation rate of carrier fluid is high. In this case, it is necessary to add carrier fluid without colorant from a replenishment carrier fluid supply to maintain the colorant concentration level within the desired predetermined range for proper operation of the ink jet printing system.

Prior art ink replenishment systems have employed ink viscosity measurement or ink optical density measurement to determine the amount of replenishment carrier fluid to add to the ink to maintain the desired concentration of colorant. These methods require the use of complex and expensive hardware, and are difficult to calibrate, for example, when the color or chemical make-up of the ink used in the system is changed, manual recalibration of the system is required. The light source and detector in the optical density measurement technique need to be recalibrated and/or changed. Furthermore, the cells through which the ink flows in the optical density measurement apparatus are quite thin and distortion of the geometry of the cells due to pressure changes in the ink can effect the accuracy of the measurement.

Another prior art system for replenishing ink in an ink jet printer is described in U.S. Patent 4,121,222 filed October 17, 1978 in the name of Diebold, et al. This system uses a printed drop count to determine how much replacement ink should be added and employs a balance scale to determine how much replenishment carrier fluid is needed. This system suffers from the problem that the hardware is complex and expensive. It is difficult to recalibrate when different batches of ink having slightly dif-

ferent concentrations of colorant and carrier fluid are used in the ink jet printer. It further suffers from the drawback that the measurement of ink by counting drops is an indirect measurement of ink volume and not as accurate as directly measuring a physical property of the ink.

There is a need therefore for an improved system for replenishing ink in an ink jet printer of the type having a main ink supply, a supplemental ink supply and a replenishment carrier fluid supply that is easily calibrated, inexpensive and capable of maintaining the ink concentration in the ink jet printer during both high and low printing rates.

Summary of the Invention

This need is met by the system and method of the present invention wherein the resistivity of the ink in the main ink supply is measured and the ink and/or replenishment carrier fluid are added to the main ink supply to maintain a desired resistivity. Ink used in continuous ink jet printers must be conductive so that the drops can be controlled by electrostatic deflection. As the ink evaporates, the salts which cause the ink to be conductive are left behind, causing the ink to be more conductive (i.e. lower resistivity). Thus, ink concentration is directly related to ink resistivity. The replenishment carrier fluid used in such printers does not contain the salts that make the ink conductive. Therefore, when carrier fluid is added to the ink, the conductivity of the ink is lowered (resistivity raised).

In one embodiment of the invention, the volume of the ink in the main ink supply is monitored, and when a predetermined volume has been depleted, the predetermined volume is replaced by either ink from the supplemental ink supply or replenishment carrier fluid from the replenishment carrier fluid supply based on the measured resistivity of the ink in the main ink supply. According to a further aspect of the present invention, the resistivity of the ink in the supplemental ink supply is also measured and when the resistivity of a new batch of ink differs from that of a previously measured batch, the desired resistivity values for the ink in the main ink supply is adjusted accordingly.

The ink replenishment system and method of the present invention is simpler and less expensive than the prior art optical density, viscosity and drop counting measurement systems and according to a further feature of the invention is capable of automatically calibrating when the ink is changed. The system is advantageous over the drop counting method in that any slight error in the calculated volume of each drop does not affect the ink concentration.

Brief Description of the Drawings

Fig. 1 is a schematic diagram of an ink replenishment system according to the present invention; Fig. 2 is a schematic diagram illustrating the ink resistivity sensor shown in Fig. 1;

Fig. 3 is a perspective view of the ink resistivity cell employed in the ink resistivity sensor shown in Fig. 2; and

Fig. 4 is a flow diagram illustrating the control logic employed in the logic and control unit in the replenishment system shown in Fig. 1.

Detailed Description of the Invention

Referring to the drawings, Fig. 1 shows an ink replenishment system for use in a continuous ink jet printer according to the present invention. The ink jet printer includes a printhead 10 to which conductive ink is supplied under pressure by an ink pump 12 through fluid line 13 which draws ink from a main ink supply 14. The printhead 10 includes a plurality of orifices (not shown) that produce a plurality of ink jets 16 which break up into uniform streams of ink drops. Ink drops selected for printing are given an electrostatic charge different from non print drops. Ink drops which are not used for printing are directed into a catcher 18 and recirculated into the main ink supply 14 by fluid line 20. The main ink supply 14 is maintained at negative atmospheric pressure by a vacuum pump 22. Any suitable means can be employed to create the vacuum such as an aspirator or mechanical vacuum pump. The vacuum created by the vacuum pump 22 is effective in drawing the unprinted ink from the catcher 18 to the main ink supply 14. It will be clear to one skilled in the art that filters, flow restrictors and other components can be used in the ink jet printing system of the present invention without departing from the spirit or scope of the invention.

A float switch 24 located in the main ink supply 14 senses when the level of ink in the main ink supply 14 is high and when the level drops to a predetermined low level. The float switch sends a high or low signal on line 25 or 26, respectively, to a logic and control unit 28.

A supplemental ink supply 30 is connected to main ink supply 14 by fluid line 32 through a normally closed valve 34. A replenishment carrier fluid supply 36 is connected to main ink supply 14 by fluid line 38 through a normally closed valve 40. Normally closed valves 34 and 40 are controlled by logic and control unit 28 to open and allow ink or replenishment carrier fluid to flow into ink supply 14 from supplemental ink supply 30 or replenishment carrier fluid supply 36 respectively. A resistivity sensor 42 located in fluid line 13 measures the resistivity of ink pumped from the main ink supply 14 to the printhead 10 and sends a signal representing the resistivity of the ink on line 44 to the logic and control unit 28. Similarly, a resistivity sensor 46 located in fluid line 32 measures the resistivity of the ink drawn from supplemental ink supply 30 and sends a signal representing the resistivity of the ink from the supplemental ink supply 30 to the logic and control unit on line 48.

Turning now to Fig. 2, the resistivity sensor 42 (and similarly 46) is shown in more detail. The resistivity sensor 42 includes fixed resistors R1, R2 and R3 and a resistance cell 50 connected in a bridge configuration. A

voltage source 52 is applied across the bridge and the values of the voltage at the nodes of the bridge are applied to a multiplexer 54 through buffer amplifiers 56, 58 and 60. Optionally, a thermistor 62 is provided on the resistance cell 50 to measure the temperature of the ink passing through the cell 50. The outputs of the thermistor 62 is also applied to the multiplexer 54 through a buffer amplifier 64. Multiplexer 54 sequentially supplies the voltage values at the nodes of the bridge and the thermistor output value to the input of an analog to digital converter 66, which in turn digitizes the voltage values and supplies them sequentially to the logic and control unit 28 where the resistivity of the ink in resistance cell 50 is calculated from the known resistance R1, R2 and R3. Optionally, the temperature of the ink can also be used to adjust the resistivity value calculated to normalize the resistivity value to a standard temperature.

Fig. 3 is a perspective view of the resistance cell 50, which includes a hollow body 68 of insulating material. A first conductive metal fitting 70 is attached to one side of the hollow body 68 through which ink can enter the hollow body. A second similar conductive metal fitting is supplied on the opposite side of the hollow body 68. Conductive lugs 72 and 74 are in electrical contact with the conductive metal fittings and provide the connections to the bridge circuit shown in Fig. 2. In operation, fluid line 13 is connected to the conductive fitting 70 and its opposite counterpart. Likewise, for conductivity sensor 46, fluid line 32 is connected to the conductive fittings.

Referring now to Fig. 1 and 4, the operation of the replenishment system under control of the logic and control unit 28 will be described. Logic and control unit 28 monitors the state of the float switch 24. When the float switch 24 indicates that the level of ink in the main ink supply 14 is low (76), the logic and control unit checks whether the resistivity of the ink in the main ink supply 14 is lower (78) than a previously calculated desired value, thereby indicating that the concentration of colorant in the ink is high due to evaporation of carrier fluid. If the resistivity of the ink is low, the logic and control unit 28 opens valve 40 to allow replenishment carrier fluid to flow from supply 36 to the main ink supply 14 until the float switch 24 indicates that the main ink supply level is high (80). On the other hand, if the resistivity of the ink in the main ink supply 14 is not low, the logic and control unit 28 opens valve 34 to allow ink to flow from the supplemental ink supply 30 into the main ink supply 14 until the float switch in the main ink supply registers high (82). In this way, the resistivity of the ink and hence the concentration of the ink in the main ink supply is maintained at or near the desired value over time by refilling the main ink supply 14 from either the supplemental ink supply 30 or the replenishment carrier fluid supply 36 depending on the measured resistivity of ink in the main ink supply 14.

According to a further feature of the present invention, the desired resistivity value of the ink in the main ink supply 14 is automatically updated when the resistivity of the ink in the supplemental ink supply 30 changes.

This change may occur when a new batch of ink having a different resistivity is added to the supplemental ink supply 30.

This automatic change is accomplished by the logic and control unit 28 monitoring the resistivity of the ink in the supplemental ink supply 30 via resistivity sensor 46. When the resistivity of the ink in the supplemental ink supply is not the same as previously measured (84), the logic and control unit 28 updates the desired resistivity value (86) by calculating a new resistivity value ρ_{new} as follows:

$$\rho_{new} = f \rho_{fresh} + (1 - f) \rho_{old}$$

where:

ρ_{new} is the updated desired resistivity value;

ρ_{fresh} is the measured resistivity value of the ink in the supplemental ink supply 30;

ρ_{old} is the previously calculated desired resistivity value; and

f is the volume fraction of liquid added to the main ink supply

= refill value total supply volume = constant set in logic & control unit at the time of manufacture of the system.

This new desired resistivity value is recalculated each time the main ink supply 14 is replenished from the supplemental ink supply 30. It has been observed for best results that the measurement of the resistivity of the ink should be done while the ink is flowing through the cell.

It will be apparent to one skilled in the art that other approaches to replenishing ink in a continuous ink jet printer employing resistivity of the ink are possible within the scope of the present invention as defined in the appended claims. For example, the logic and control unit may calculate a proportion of supplemental ink and carrier fluid to add to the main ink supply to restore the resistivity to the desired value.

Claims

1. In a continuous ink jet printer employing conductive ink and having a main ink supply, a supplemental ink supply, and a replenishment carrier fluid supply, an ink replenishment system, comprising:
 - a. means for sensing the resistivity of ink in the main ink supply; and
 - b. means responsive to said sensing means for controlling the transfer of ink from the supplemental ink supply and the transfer of carrier fluid from the replenishment carrier fluid supply to the main ink supply.

2. The ink replenishment system claimed in Claim 1 wherein said means for controlling comprises:
 - a. means for sensing when a predetermined volume of ink is depleted from said main ink supply; and
 - b. means responsive to said volume sensing means for transferring said predetermined volume of ink from said supplemental ink supply to said main ink supply when the resistivity of ink in said main ink supply is above a predetermined value, and for transferring said predetermined volume of carrier fluid from said replenishment carrier fluid supply to said main ink supply when the resistivity of ink in said main ink supply is below said predetermined value.

3. The ink replenishment system claimed in Claim 2, further comprising:
 - a. supplemental sensing means for measuring the resistivity of ink in said supplemental ink supply; and
 - b. means responsive to said supplemental sensing means for adjusting said predetermined resistivity value.

4. The ink replenishment system claimed in Claim 3, wherein said adjusting means adjusts said predetermined resistivity value according to the following rule:

$$\rho_{new} = f \rho_{fresh} + (1 - f) \rho_{old},$$

where:

ρ_{new} is the updated desired resistivity value, ρ_{fresh} is the measured resistivity value of the ink in the supplemental ink supply, ρ_{old} is the previously calculated desired resistivity value, and f is a constant representing a volume fraction of liquid added to the main ink supply.

5. The ink replenishment system claimed in Claims 2 or 3, wherein said volume sensing means comprises a float switch located in said main ink supply.
6. The ink replenishment system claimed in Claim 2 or 3, wherein said resistivity sensing means comprises:
 - a hollow insulating body, a pair of conductive metal fittings for introducing ink into and out of the body, and a pair of electrical connections to said metal fittings.
7. A method of replenishing the ink in an ink jet printer of the type having a main ink supply, a supplemental ink supply and a replenishment carrier fluid supply, comprising the steps of:

- a. sensing the resistivity of ink in the main ink supply; and
 b. replenishing the ink in the main ink supply with ink from the supplemental ink supply and carrier fluid from the replenishment carrier fluid supply as a function of the resistivity of the ink in the main ink supply. 5
8. The method claimed in Claim 7, wherein said replenishing step comprises the steps of: 10
- a. sensing when a predetermined volume of ink is depleted from the main ink supply; and
 b. replacing the predetermined volume of ink in the main ink supply with ink from the supplemental ink supply if the resistivity of the ink in the main ink supply is higher than a predetermined value and replacing the predetermined volume of ink in the main ink supply with carrier fluid from the replenishment carrier fluid supply if the resistivity of ink in the main ink supply is below a predetermined value. 20
9. The method claimed in Claim 7 or 8 further comprising the steps of: 25
- a. sensing the resistivity of ink in the supplemental ink supply; and
 b. updating said predetermined value as a function of the resistivity of ink in the supplemental ink supply. 30

Patentansprüche

1. Tintenwiederauffüllvorrichtung in einem kontinuierlich arbeitenden, leitfähige Tinte verwendenden Tintenstrahldrucker mit einer Haupttintenversorgung, einer Ergänzungstintenversorgung und einer Trägerflüssigkeitswiederauffüllversorgung, folgendes umfassend: 35
- (a) Mittel zum Messen des Widerstands der Tinte in der Haupttintenversorgung und
 (b) auf die Meßmittel reagierende Mittel zur Steuerung des Transports von Tinte aus der Ergänzungstintenversorgung und des Transports von Trägerflüssigkeit aus der Trägerflüssigkeitswiederauffüllversorgung zur Haupttintenversorgung. 40
2. Tintenwiederauffüllvorrichtung nach Anspruch 1, dadurch **gekennzeichnet**, daß die Mittel zur Steuerung folgendes umfassen: 45
- (a) Mittel zum Messen, wann ein vorbestimmtes Tintenvolumen aus der Haupttintenversorgung entnommen worden ist, und 50

(b) auf die Volumenmeßmittel reagierende Mittel zum Transportieren des vorbestimmten Tintenvolumens aus der Ergänzungstintenversorgung zur Haupttintenversorgung, falls der Widerstand der Tinte in der Haupttintenversorgung oberhalb eines vorbestimmten Wertes liegt, und zum Transportieren des vorbestimmten Volumens an Trägerflüssigkeit aus der Trägerflüssigkeitswiederauffüllversorgung zur Haupttintenversorgung, falls der Widerstand der Tinte in der Haupttintenversorgung unterhalb des vorbestimmten Wertes liegt.

3. Tintenwiederauffüllvorrichtung nach Anspruch 2, dadurch **gekennzeichnet**, daß sie ferner folgendes umfaßt:

(a) zusätzliche Meßmittel zum Messen des Widerstands der Tinte in der Ergänzungstintenversorgung und

(b) auf die zusätzlichen Meßmittel reagierende Mittel zum Einstellen des vorbestimmten Widerstandswertes.

4. Tintenwiederauffüllvorrichtung nach Anspruch 3, dadurch **gekennzeichnet**, daß die Einstellmittel den vorbestimmten Widerstandswert gemäß der folgenden Regel einstellen:

$$\rho_{\text{neu}} = f \cdot \rho_{\text{frisch}} + (1-f) \cdot \rho_{\text{alt}}$$

wobei ρ_{neu} der aktualisierte gewünschte Widerstandswert ist, ρ_{frisch} der gemessene Widerstandswert der Tinte in der Ergänzungstintenversorgung ist, ρ_{alt} der früher berechnete gewünschte Widerstandswert ist, und f eine Konstante ist, die einen Volumenbruchteil der der Haupttintenversorgung zugeführten Flüssigkeit darstellt.

5. Tintenwiederauffüllvorrichtung nach Anspruch 2 oder 3, dadurch **gekennzeichnet**, daß die Volumenmeßmittel einen in der Haupttintenversorgung angeordneten Schwimmerschalter umfassen.
6. Tintenwiederauffüllvorrichtung nach Anspruch 2 oder 3, dadurch **gekennzeichnet**, daß die Widerstandsmeßmittel folgendes umfassen: einen hohlen isolierenden Körper, ein Paar leitender Metallanschlußstücke, um Tinte in den Körper hinein- und hinauszuführen, sowie ein Paar elektrischer Anschlußleitungen zu den Metallanschlußstücken.
7. Verfahren zum Wiederauffüllen der Tinte in einem Tintenstrahldrucker mit einer Haupttintenversorgung, einer Ergänzungstintenversorgung und einer Trägerflüssigkeitswiederauffüllversorgung, das die folgenden Verfahrensschritte umfaßt: 55

(a) Messen des Widerstands der Tinte in der Haupttintenversorgung und

(b) Wiederauffüllen der Tinte in der Haupttintenversorgung mit Tinte aus der Ergänzungstintenversorgung und Trägerflüssigkeit aus der Trägerflüssigkeitswiederauffüllversorgung als Funktion des Widerstands der Tinte in der Haupttintenversorgung.

8. Verfahren nach Anspruch 7, dadurch **gekennzeichnet**, daß der Wiederauffüllschritt die folgenden Schritte umfaßt:

(a) Messen, wenn ein vorbestimmtes Tintenvolumen aus der Haupttintenversorgung entnommen worden ist, und

(b) Ersetzen des vorbestimmten Tintenvolumens in der Haupttintenversorgung durch Tinte aus der Ergänzungstintenversorgung, falls der Widerstand der Tinte in der Haupttintenversorgung größer ist als ein vorbestimmter Wert, und Ersetzen des vorbestimmten Tintenvolumens in der Haupttintenversorgung durch Trägerflüssigkeit aus der Trägerflüssigkeitswiederauffüllversorgung, falls der Widerstand der Tinte in der Haupttintenversorgung kleiner ist als ein vorbestimmter Wert.

9. Verfahren nach Anspruch 7 oder 8, dadurch **gekennzeichnet**, daß es ferner die folgenden Verfahrensschritte umfaßt:

(a) Messen des Widerstands der Tinte in der Ergänzungstintenversorgung und

(b) Aktualisieren des vorbestimmten Wertes als Funktion des Widerstands der Tinte in der Ergänzungstintenversorgung.

Revendications

1. Dans une imprimante à jet d'encre continu utilisant de l'encre conductrice et ayant un réservoir d'encre principal, un réservoir d'encre supplémentaire et un réservoir de fluide porteur de remplissage, un système de remplissage d'encre comportant:

a. un moyen pour détecter la résistivité de l'encre dans le réservoir d'encre principal; et
b. un moyen qui réagit audit moyen de détection pour commander le transfert de l'encre et du fluide porteur respectivement du réservoir d'encre supplémentaire et du réservoir de fluide porteur au réservoir d'encre principal.

2. Système de remplissage d'encre selon la revendication 1, dans lequel ledit moyen de commande comporte:

a. un moyen pour détecter le moment où l'encre a diminué d'un volume prédéterminé dans ledit réservoir d'encre principal; et
b. un moyen qui réagit audit moyen de détection de volume pour transférer ledit volume d'encre prédéterminé dudit réservoir d'encre supplémentaire audit réservoir d'encre principal quand la résistivité de l'encre dans ledit réservoir d'encre principal est supérieure à une valeur prédéterminée, et pour transférer ledit volume de fluide porteur dudit réservoir de fluide porteur de remplissage audit réservoir d'encre principal quand la résistivité de l'encre dans ledit réservoir d'encre principal est inférieure à ladite valeur prédéterminée.

3. Système de remplissage d'encre selon la revendication 2, comportant en outre:

a. un moyen supplémentaire de détection pour mesurer la résistivité de l'encre dans ledit réservoir d'encre supplémentaire; et
b. un moyen qui réagit audit moyen supplémentaire de détection pour régler ladite valeur de résistivité prédéterminée.

4. Système de remplissage d'encre selon la revendication 3, dans lequel ledit moyen de réglage règle ladite valeur de résistivité prédéterminée selon la règle suivante:

$$\rho_{\text{nouv}} = f \cdot \rho_{\text{mes}} + (1-f) \cdot \rho_{\text{pranc}}, \text{ où}$$

ρ_{nouv} est la valeur de résistivité souhaitée mise à jour, ρ_{mes} est la valeur de résistivité mesurée pour l'encre du réservoir d'encre supplémentaire, ρ_{pranc} est la valeur de résistivité souhaitée précédemment calculée, et f est une constante représentant une fraction du volume de liquide ajouté au réservoir d'encre principal.

5. Système de remplissage d'encre selon la revendication 2 ou la revendication 3, dans lequel ledit moyen de détection de volume comporte un commutateur flottant situé dans ledit réservoir d'encre principal.

6. Système de remplissage d'encre selon la revendication 2 ou la revendication 3, dans lequel ledit moyen de détection de résistivité comporte:

un corps isolant creux, une paire de raccords en métal conducteur pour faire circuler l'encre dans le corps et une paire de connexions électriques auxdits raccords métalliques.

7. Procédé de remplissage d'encre dans une imprimante à jet d'encre du type ayant un réservoir d'encre principal, un réservoir d'encre supplémentaire et un réservoir de fluide porteur de remplissage, comportant les étapes de: 5
- a. détection de la résistivité de l'encre dans le réservoir d'encre principal; et
 - b. remplissage du réservoir d'encre principal avec de l'encre provenant du réservoir d'encre supplémentaire et du fluide porteur provenant du réservoir de fluide porteur de remplissage, en fonction de la résistivité de l'encre dans le réservoir d'encre principal. 10
8. Procédé selon la revendication 7, dans lequel ladite étape de remplissage comporte les étapes de: 15
- a. détection du moment où l'encre a diminué d'un volume prédéterminé dans le réservoir d'encre principal; et 20
 - b. remplacement du volume prédéterminé d'encre dans le réservoir principal par de l'encre provenant du réservoir d'encre supplémentaire si la résistivité de l'encre dans le réservoir d'encre principal est supérieure à une valeur prédéterminée, et remplacement du volume prédéterminé d'encre dans le réservoir principal par du fluide porteur provenant du réservoir de fluide porteur de remplissage si la résistivité de l'encre dans le réservoir d'encre principal est inférieure à une valeur prédéterminée. 25 30
9. Procédé selon la revendication 7 ou la revendication 8, comportant en outre les étapes de: 35
- a. détection de la résistivité de l'encre dans le réservoir d'encre supplémentaire; et
 - b. mise à jour de ladite valeur prédéterminée en fonction de la résistivité de l'encre dans le réservoir d'encre supplémentaire. 40

45

50

55

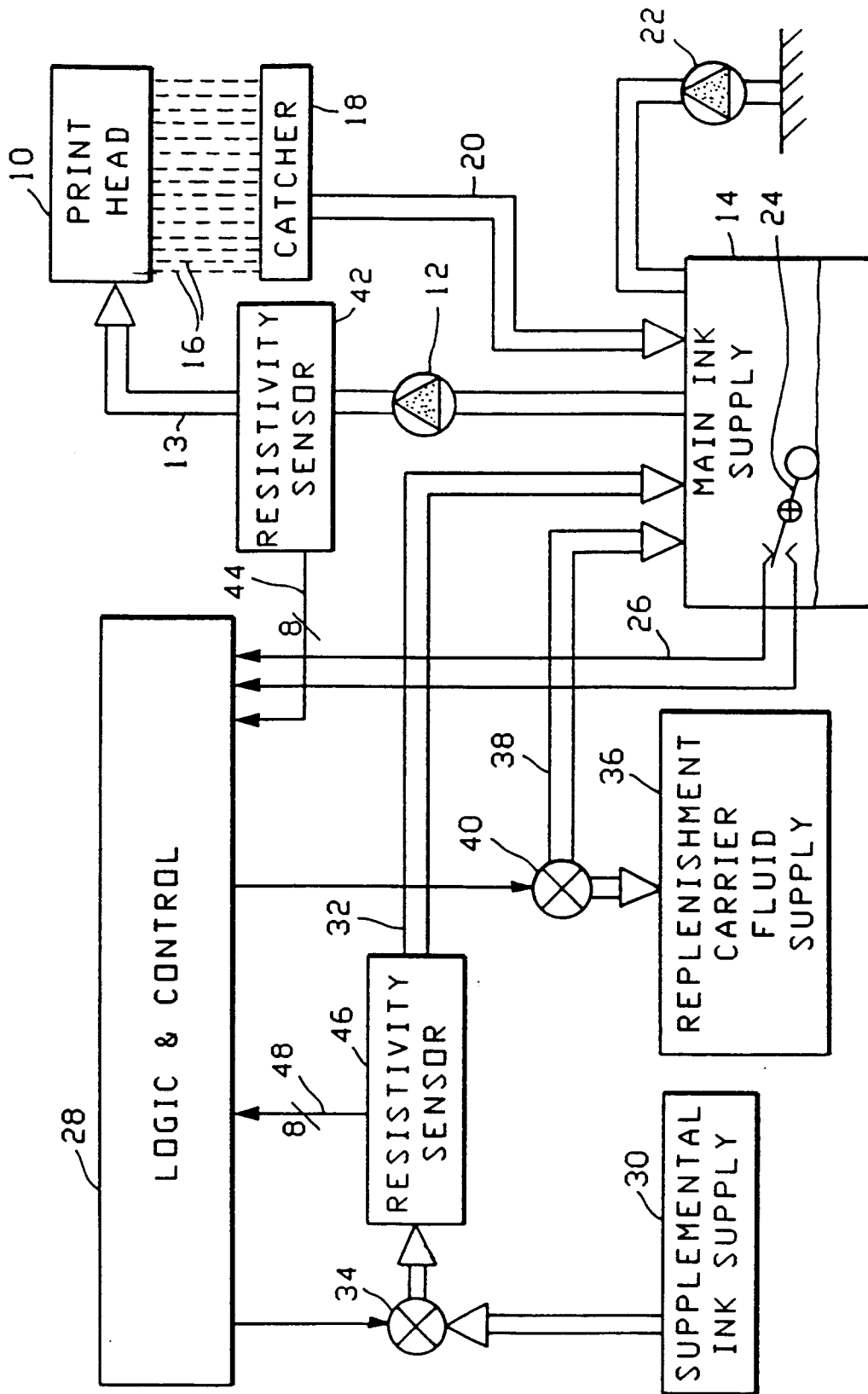

FIG. 1

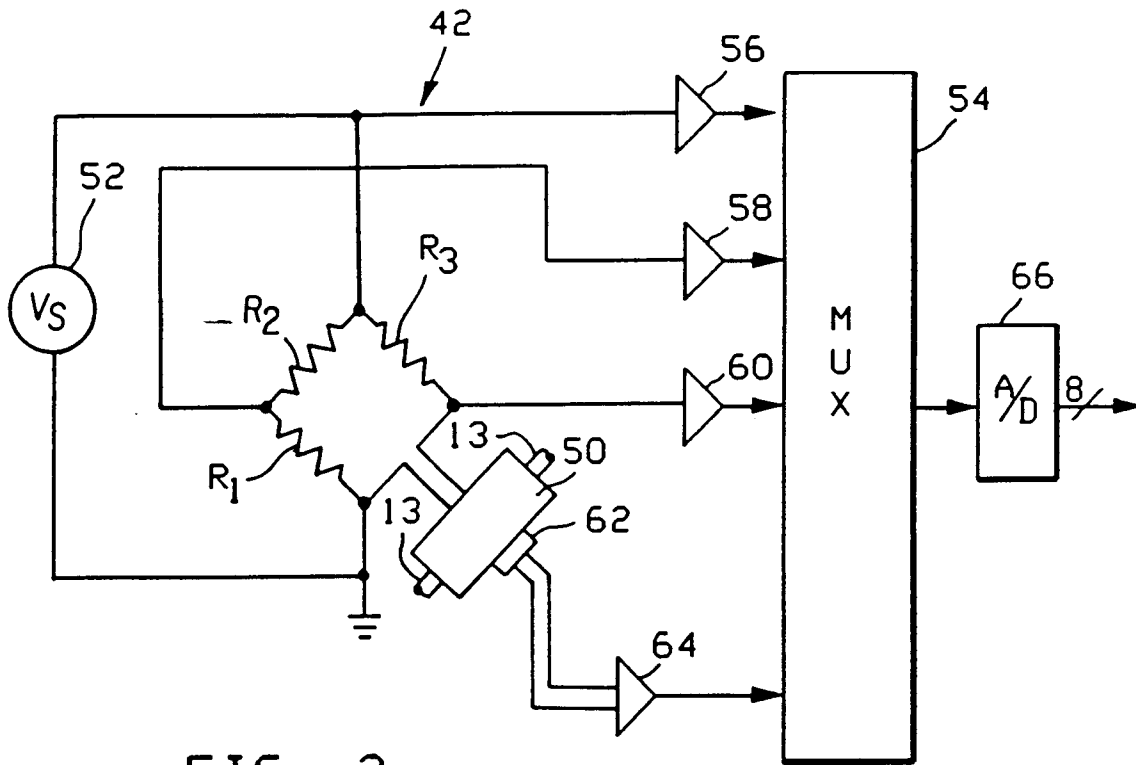

FIG. 2

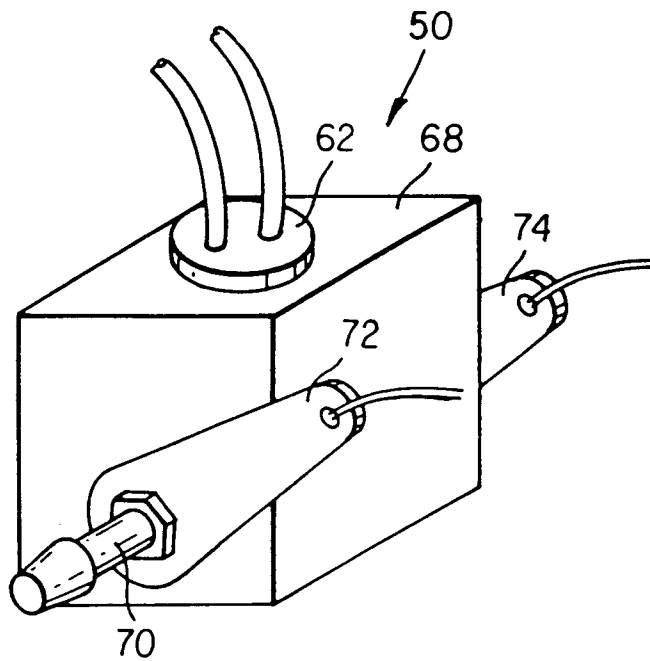

FIG. 3

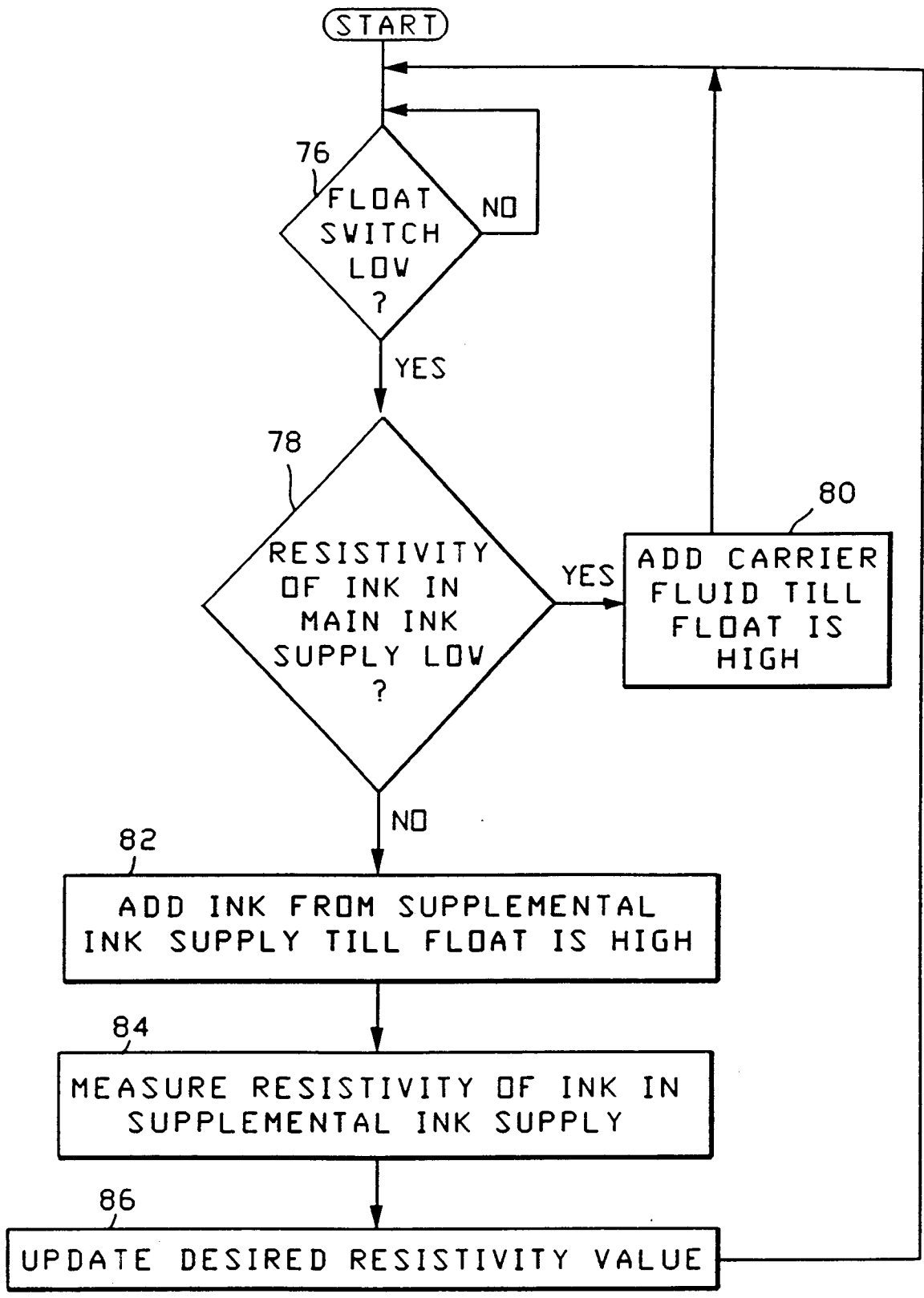

FIG. 4