

J. T. & F. ASHLEY.
PAPER-FEEDING MACHINE.

No. 182,146.

Patented Sept. 12, 1876.

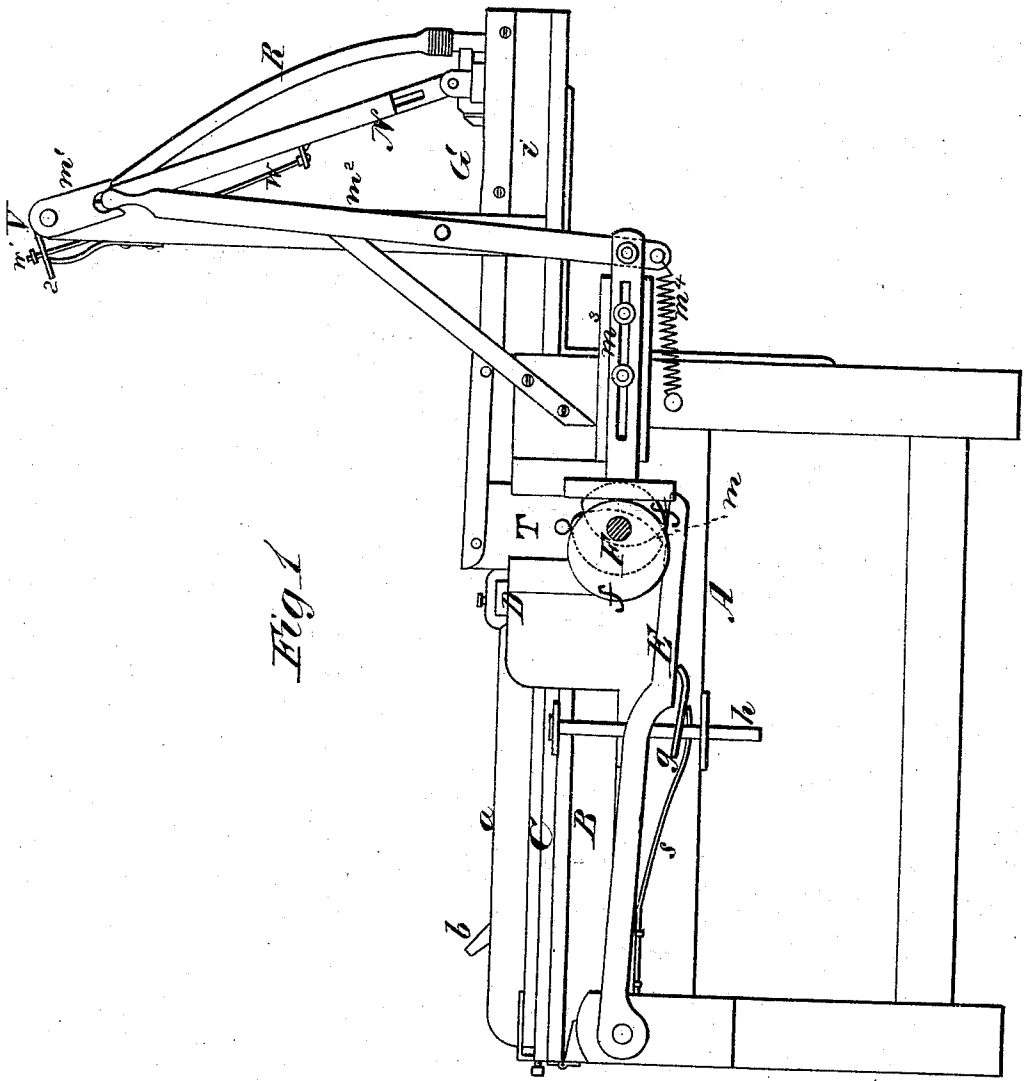

Fig 1

WITNESSES
E. H. Bates
Robert Green

INVENTORS
John T. Ashley
Fred. S. Ashley
 Chipman, Hooper & Co ATTORNEYS,

J. T. & F. ASHLEY.
PAPER-FEEDING MACHINE.

No. 182,146.

Patented Sept. 12, 1876.

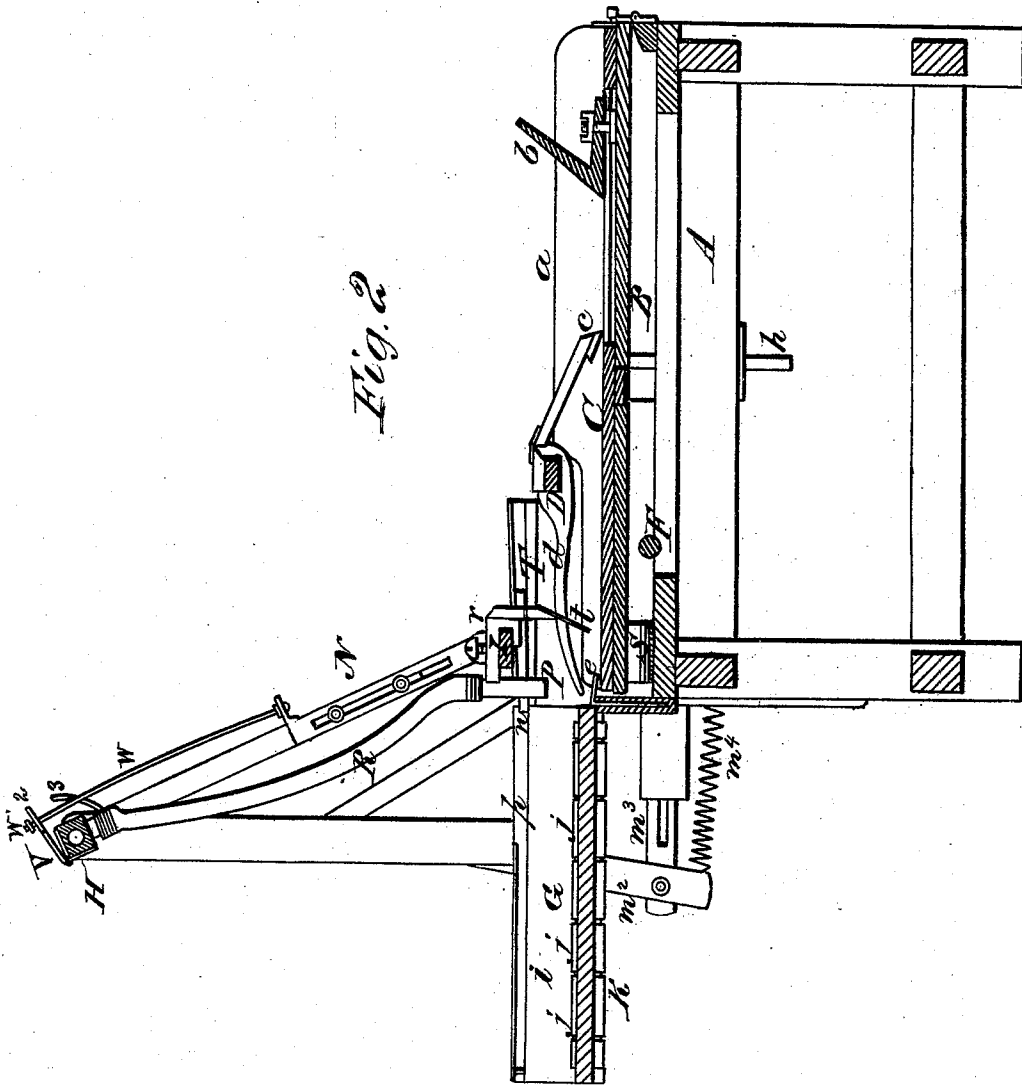

Fig. 2

WITNESSES
A. Bates
Robert Everett

INVENTOR'S
John T. Ashley
Fred. K. Ashley
Chipman Hoaman & Co ATTORNEYS.

J. T. & F. ASHLEY.
PAPER-FEEDING MACHINE.

No. 182,146.

Patented Sept. 12, 1876.

Fig. 3

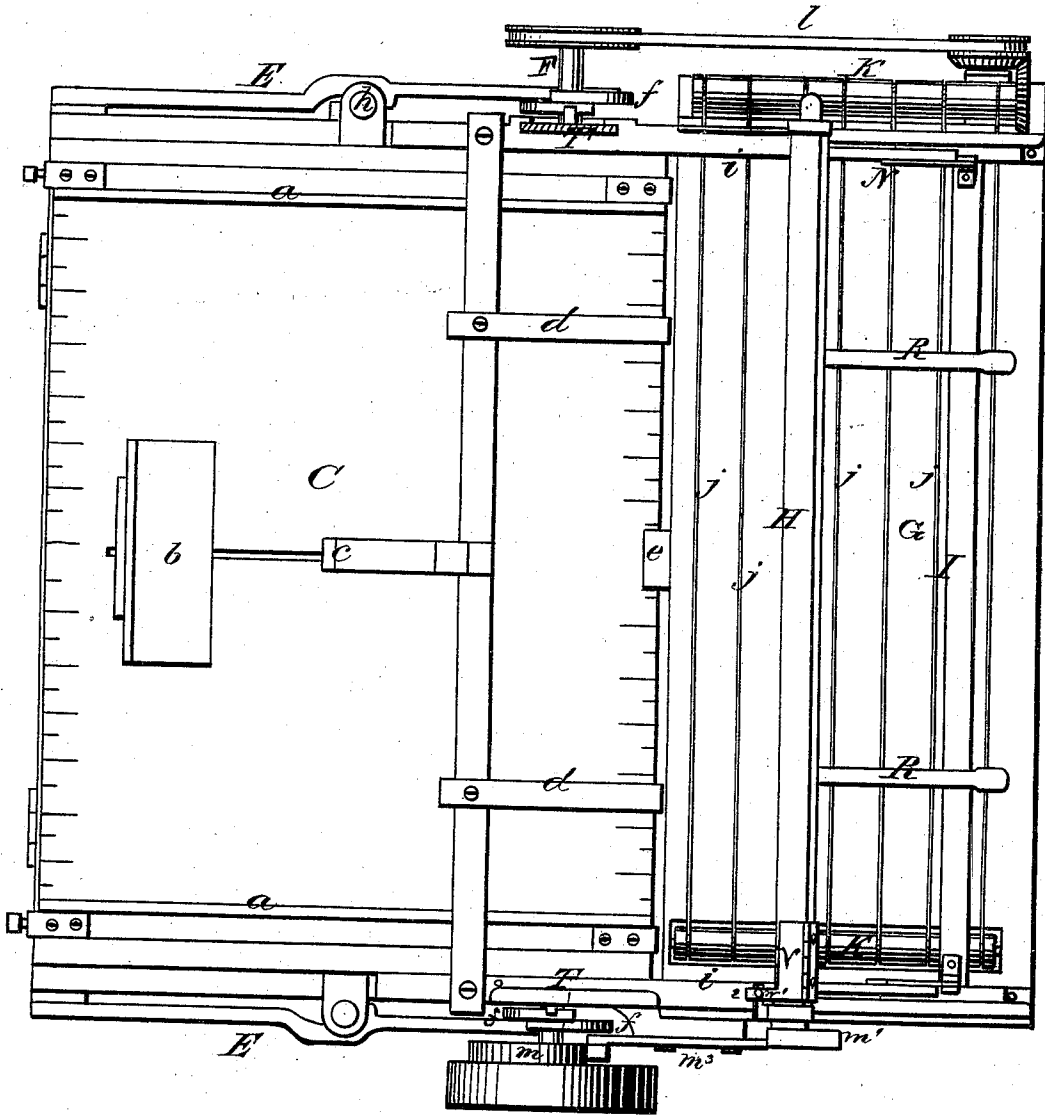

WITNESSES

J. H. Bates
Robert Everett

INVENTOR, S.

John T. Ashley
Fred. E. Ashley
Chipman, Hooper & Co. ATTORNEYS

J. T. & F. ASHLEY.
PAPER-FEEDING MACHINE.

No. 182,146.

Patented Sept. 12, 1876.

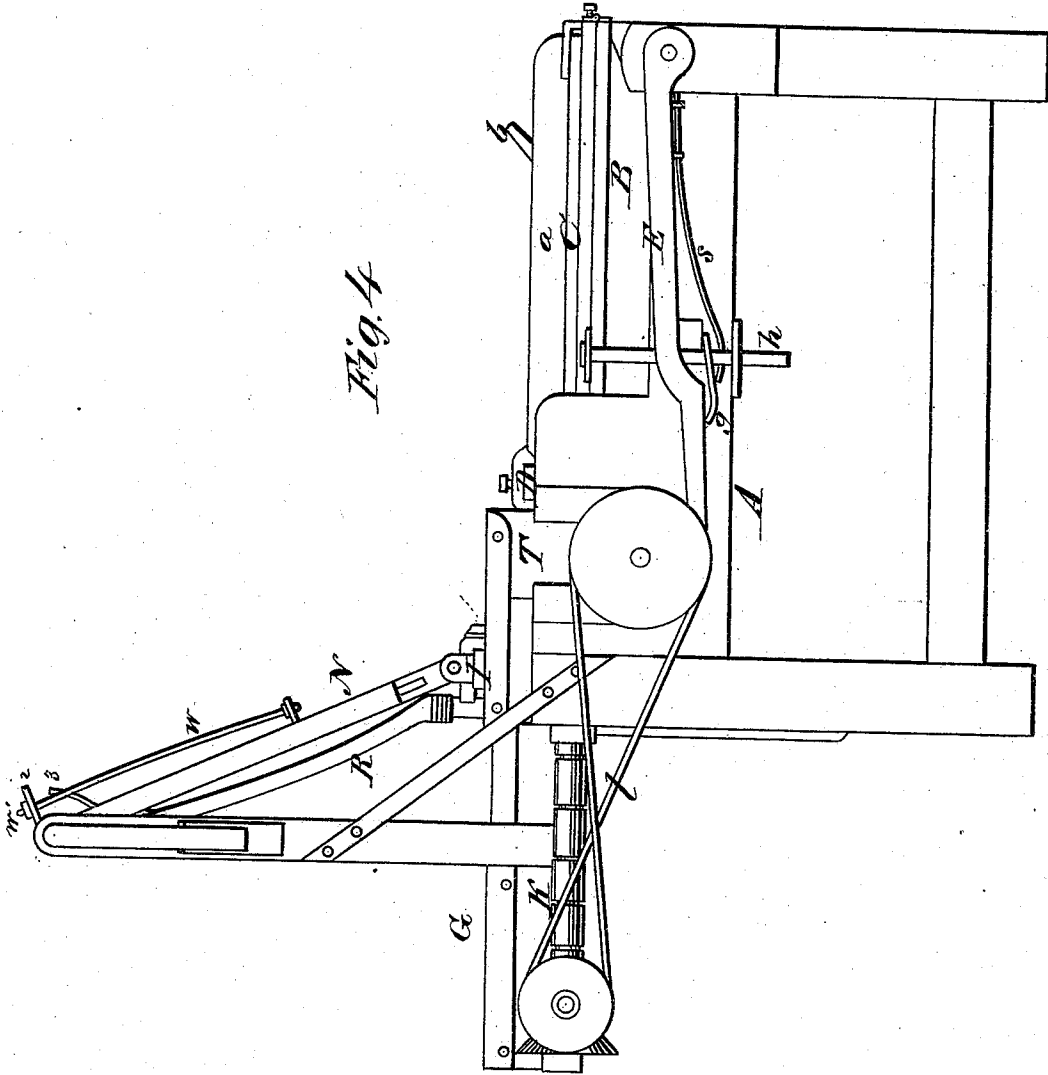

Fig. 4

WITNESSES
E. H. Bates
Robert Everett

INVENTORS.
John T. Ashley
Fred. K. Ashley
Chipman, Hoanin & Co ATTORNEYS.

J. T. & F. ASHLEY.
PAPER-FEEDING MACHINE.

No. 182,146.

Patented Sept. 12, 1876.

Fig. 5

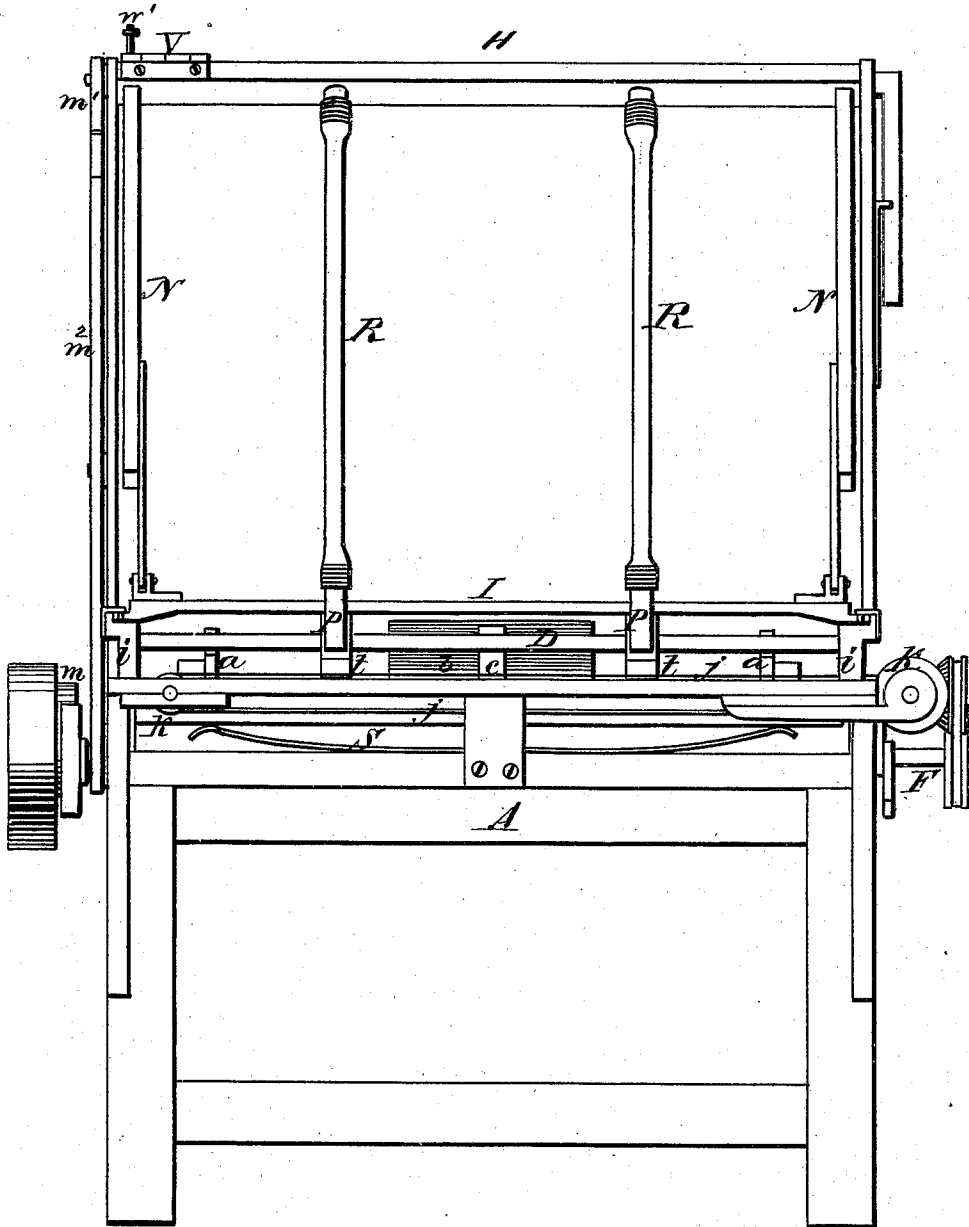

WITNESSES
E. H. Bates
Robert. Everett

INVENTOR J.
John T. Ashley
Fred. S. Ashley

Chipman, Hanson & Co. ATTORNEYS.

UNITED STATES PATENT OFFICE.

JOHN T. ASHLEY AND FREDERICK ASHLEY, OF WILLIAMSBURG, N. Y.

IMPROVEMENT IN PAPER-FEEDING MACHINES.

Specification forming part of Letters Patent No. 182,146, dated September 12, 1876; application filed January 8, 1876.

To all whom it may concern:

Be it known that we, JOHN T. ASHLEY and FREDERICK ASHLEY, of Williamsburg, in the county of Kings and State of New York, have invented a new and valuable Improvement in Paper-Feeders; and we do hereby declare that the following is a full, clear, and exact description of the construction and operation of the same, reference being had to the annexed drawings, making a part of this specification, and to the letters and figures of reference marked thereon.

Figure 1 of the drawings is a representation of a side view of our paper-feeding machine, and Fig. 2 is a longitudinal vertical sectional view thereof. Fig. 3 is a plan view, Fig. 4 a side view, and Fig. 5 an end view, of the same.

The object of this invention is to improve machines which are designed for feeding sheets of paper, one sheet at a time, to printing-presses and other machines.

The nature of our invention consists, first, in a tray or table, having an intermittent vibrating motion, on which the pile of paper is placed, having laterally-adjustable side guides, and also an adjustable inclined back, which, with a pushing-back foot or feet, will free the topmost sheet from the next sheet below it previous to the removal of such sheet from the pile, as will be hereinafter explained.

Second, in a novel device, actuated by a cam on the main driving-shaft, for automatically depressing the feed-table and its removable tray previous to the picking up of the topmost sheet of the pile, as will be hereinafter explained.

Third, in means which will lift and carry the sheet of paper forward to the feed-board, then release it to receive its side register, in combination with tapes of the feed-board running at right angles to the side guide and friction-fingers, for adjusting the front edge of the sheet to the guides of a printing-press.

Fourth, in a vertically and horizontally reciprocating bar, carrying pneumatic picking-up fingers, and actuated by means of vibrating extensible arms, attached to an oscillating trunk, in combination with flexible pipes com-

municating with said fingers and trunk, as will be hereinafter explained.

Fifth, in extensible vibrating arms and a reciprocating bar, carrying picking-up fingers, in combination with a valve, which is applied to the oscillating trunk, and which is opened and shut automatically, as will be hereinafter explained.

In the annexed drawings, A designates the frame of the machine, and B is a table, which is hinged to said frame at its rear end, so that it can receive a vertical vibrating motion. On this table is a removable tray, C, to which are affixed laterally-adjustable side guides *a a*, and an inclined longitudinally-adjustable back, *b*, which presents a rough surface.

The object of this back *b* is, that when the top sheet of the pile is pushed back by the action of a frictional foot, *c*, the friction of the roughened surface of said back shall keep down the next sheet below.

The foot *c* is applied to a bar, D, extending across the frame A, and is located at or near the middle of the width of the tray C.

If desired, two frictional feet, *c*, may be employed, in which case we prefer to attach them to two stops, *d d*, adjustably secured to the bar D.

The front of the tray is held up by means of a spring, S, beneath the front edge of the table, and the topmost sheet of the pile is gently pressed by said spring against the two stops *d d*, which are placed at the front end instead of the side of the frame. At the front of the tray C is a self-adjusting clamp, *e*, the horizontal lip of which is designed to act on the top of the pile of paper. When the topmost sheet is pushed back from beneath the clamp *e* by means of the foot *c*, this clamp will rest upon the next sheet below.

E E designate two levers, which are pivoted to the sides of the frame A near its front end, the free ends of which are held up against single-throw cams *f* on the main shaft F, by means of springs *s*. These levers E are depressed at every revolution of the shaft F, and operate on the table B through the medium of clamps *g* and rods *h*. The clamps *g* are loosely applied on the rods *h*, and are acted

on by levers E during the descending strokes of these levers, which cause them to bite on the rods *h*, and pull down the table with its tray, and the pile of paper on it. The clamps *g* do not resist the ascent of the table.

G designates the feed-board, which is attached in any suitable manner to the frame A, and provided with sides *i i*, against one or the other of which the sheets are moved and registered by means of endless tapes *j*. These tapes pass around rollers *k k*, and they are arranged at right angles to the sides *i i*, so that, when a sheet is moved forward on the feed-board G, it will be carried in a lateral direction and registered. Sheets can be moved either to the right or left hand registering-side *i* by running the belt *l* straight or crossed. H designates a trunk, from which air is exhausted by any suitable engine. This trunk receives oscillation from a cam, *m*, on the shaft F by means of an arm, *m*¹, lever *m*², slide *m*³, and a spring, *m*⁴.

I designates a bar, having slides *n n* secured to its ends, which move in guideways *p p*, and also in ways which are formed on sashes T. The bar I is connected to the trunk by extensible arms N N, which freely accommodate themselves to the vertical and horizontal movements which are given to the said bar. P P are picking-up fingers, which communicate with the trunk H by means of flexible tubes R R. The fingers P P are fixed to clamps *r*, which are adjustable on bar I, and to which frictional fingers are *t* secured. These fingers *t* may be secured to bar I independent of the fingers P.

V designates a valve, which is hinged to the trunk H, and constructed with a lip, 2, on one corner, through which a rod, *w*, plays freely. The rod *w* is secured to the upper end of a sliding section of one of the arms, N, and on the upper end of said rod a head, *w*¹, is formed, which closes valve V simultaneously with the contact of the fingers with the top sheet of the pile.

Valve V is opened at the proper time to drop a sheet by means of a fixed bracket, 3, against which the lip 2 strikes. The sashes T, on which the bar I rests when it is at the termination of its back-stroke, receive vertical motion from the main shaft by means of single-throw cams on this shaft.

A pile of paper is adjusted on the tray C, beneath the frictional foot *c*, the stops *d d*, and the lip of the clamp *e*. Motion is then imparted to the main shaft F, and from this shaft to the bar D, carrying the pneumatic picking-up fingers P P and frictional fingers *t*. The table B, with its tray and pile of pa-

per, receives an intermittent vibrating motion, so timed relatively to the movements of bar D that as this bar is brought over the front of the pile of paper the topmost sheet will be slipped back by the foot *c*, and freed from the next lower sheet and the clamp *e*. The table B will then descend, and at the same time the fingers P P will pick up the topmost sheet. This sheet is then carried forward on the feed-board G, and dropped just before the bar terminates its stroke.

The sheet, upon being released, receives its side register by means of the tapes of the feed-board running at right angles to the side guide. Simultaneously with the side adjustment of the sheet, the friction-fingers *t* are brought into use to adjust the front edge of the sheet to the guides of a printing-press. (Not shown in the drawings.) The sheet is released from the device which lifts and carries it by the opening of the valve V.

What we claim as new, and desire to secure by Letters Patent, is—

1. The combination of the frictional foot C, the table B, having an intermittent vibrating motion, and the adjustable inclined back *b*, for the purpose set forth.

2. The combination, with a feed-table, of a mechanism for depressing the feed-table, which consists, substantially, in levers E, cams *f*, springs *s*, rods *h*, and clamp *g*.

3. In an automatic paper-feeder, the lifting device, substantially as described, which carries the sheet of paper forward to the feed-board, then releases it to receive its side register, in combination with the tapes of the feed-board, running at right angles to the side guide, and the friction-fingers for adjusting the front edge of the sheet to the guides of a printing-press.

4. A vertically and horizontally reciprocating bar, I, actuated by extensible vibrating arms N, in combination with picking-up fingers P P, a section trunk, H, and flexible pipes R R, substantially as described.

5. Valve V, applied to the trunk H, and actuated as described, in combination with a bar, I, carrying picking-up fingers P, and with vibrating extensible arms, substantially as described.

In testimony that we claim the above we have hereunto subscribed our names in the presence of two witnesses.

JOHN T. ASHLEY.
FREDERICK ASHLEY.

Witnesses:

GEORGE E. UPHAM,
ISAAC S. WATERS.