

12

EUROPEAN PATENT APPLICATION

21 Application number: **87850376.2**

51 Int. Cl.4: **B 65 D 59/00**

22 Date of filing: **01.12.87**

30 Priority: **01.12.86 DK 5776/86**

43 Date of publication of application:
08.06.88 Bulletin 88/23

84 Designated Contracting States: **DE FR GB NL SE**

71 Applicant: **MOGENS A. STAERMOSE & SON, ODENSE A/S**
Svendborgvej 102
DK-5360 Odense S (DK)

72 Inventor: **Staermose, Bo**
Soparken 130
DK-5260 Odense S (DK)

Madsen, Mogens Lehgaard
Faborgvej 19
DK-5762 V. Skerninge (DK)

74 Representative: **Ryrlén, Evert et al**
ALFONS HEDBERGS PATENTBYRÅ AB
Aschebergsgatan 35
S-411 33 Göteborg (SE)

54 **Corner pad for packing for example glass plates.**

57 When packing placed together glass plates (1) or similar fragile plates, it is desirable to avoid damage to the plates during transportation in the package. For the protection of such stacks of glass (2, 3), corner pads can be used which are constructed of identical halves of a shock and impact absorbing expanded plastic.

Each half consists of one side piece (4) which is positioned in the space between the glass stacks (2, 3) and which at their ends are each provided with two end pieces (5, 6) resting on the end faces of the glass.

In order to hold together the halves and control these during the pushing together, each is provided with projections (8) and corresponding recesses (7), respectively, on the abutting side faces. If several corner pads are to be assembled, laterally reversed corner pads must be used on the opposite side of the glass stacks (2, 3).

In order to further improve protection, those parts on which the stacks (2, 3) rest are unbroken which makes it possible to push the parts together as glass (1) is removed from the stack.

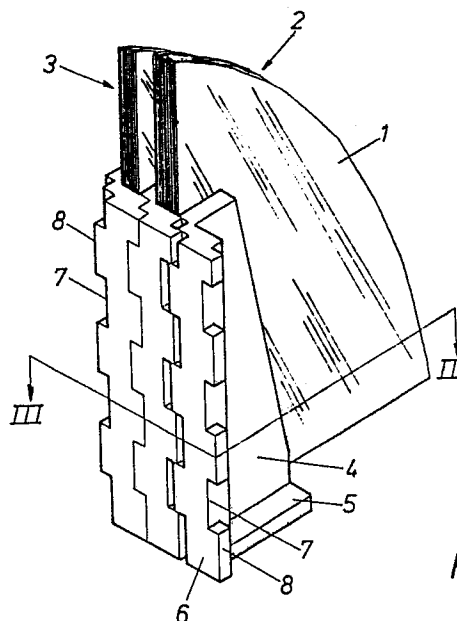

Fig. 1

Description

CORNER PAD FOR PACKING FOR EXAMPLE GLASS PLATES

The invention relates to a corner pad for the packing of a number of thin plates placed together, such as glass plates, and comprising two identical halves produced of a shock and impact absorbing material, which halves can be assembled around the corners of the plates for the creation of an outer protection.

When packing glass plates there is a need for some corner protection which can partly hold together the glass plates in the stack within the outer box or container, and partly protects the individual glass stacks against impacts from adjacent stacks. Add to this the protection of these stacks of glass in the package being for instance a box.

Such a corner pad is known from US patent no. 3,302,782, where the corner pad comprises two identical halves being constructed in such a manner that by laterally reversing the one half the halves can be fitted onto the corners of the glass stack and thereby form the protecting corner pad.

However, the known corner pads can only protect one single glass stack in that merely single corners can be formed. Moreover, the known construction of the corners is complicated which makes it difficult to produce these corners, and which at the same time makes them exposed to damage. This is because the surfaces on which the glasses rest, and the surface which protects the adjacent end of the glasses are divided so that unbroken surfaces are not formed until the parts have been pushed together.

Since the halves are manufactured of a partly yielding expanded plastic, this means that the halves cannot be pushed together once the glasses are placed and rest on the surfaces made up by the individual parts in that the weight of the glasses will deform these parts and thus hold them in their position.

Consequently, the known halves must be spaced correctly and abut the glasses when these are placed in the spaces between the parts.

Add to this that it will not be possible to push the parts together as single pieces of glass are removed, because the weight of the remaining glass will prevent the pushing together of the parts. This causes a risk of damaging the glasses in the package, because these are no longer held together by the corner pads to form a firm stack.

It is the object of the invention to eliminate these shortcomings and disadvantages of the known pads, and this is achieved by a protecting pad where each half consists of a side piece abutting the side of the outer glass plate and having two perpendicular end pieces forming a right angle and resting on the ends of the plates, said end pieces along their one side edge being provided with recesses and along their opposite side edge with corresponding projections.

First of all, a corner pad is hereby obtained which can partly make up a single corner for a single stack

of glass, but which will also form assembled additional corners for additional glass stacks in order that a package can be filled up with corner padded stacks being individually protected and having protecting pieces between each stack. This presupposes that laterally reversed corner pads are used at the opposite sides of the stacks.

Add to this that single glass plates can easily be removed, whereafter the corners are pressed together, because there will be no significant displacement between the supporting parts of the halves. Moreover, the corner can be produced in any required size in order that it offers optimum protection. If for instance a complete covering of all surfaces is required, each corner can be dimensioned so that it covers one fourth of the desired surface.

Moreover, the production of the corners will be simple in that none of the elements are difficult to make just as the projections are low, because they need not cover the gap between the side pieces. By, as related to in claim 2, positioning the cooperating recesses and projections on the outside of the end pieces, the glass plates can rest directly on unbroken protection surfaces.

By, as related to in claim 3, having the one side piece, preferably the bottom one, be an unbroken piece, this will provide the best possible support and protection for the glass.

Finally it is expedient, as related to in claim 4, to stagger the side piece in relation to the end piece because this provides the highest possible degree of rigidity and consequent protection of the glass.

In the following the invention will be described in further detail with reference to the drawing, in which

Fig. 1 is a perspective view of the corners of two glass stacks surrounded by three assembled halves,

Fig. 2 is a perspective view of the three halves alone, seen from within, and

Fig. 3 is a sectional view of the glass stacks and the halves seen in the direction of III-III in fig. 1.

The drawing shows an example of a preferred embodiment of a corner pad cast in for instance expanded polystyrene.

The protection is constructed of one single element which forms one half of the corner pad and which in the drawing is shown for the formation of two connected corner pads around two glass stacks 2, 3.

Each element of half consists of a side piece 4 forming a side wall or end wall between the glasses which are put together for the formation of two stacks 2, 3, as shown in figs. 1 and 3.

A bottom or top piece in the form of an end piece 5 extends from the side piece 4, said end piece 5 extending a distance in one direction from a distance within one side edge of the side piece 4 to a position beyond the opposite side edge of the side piece 4 so that a recess for the adjacent end piece 5 is formed

when the parts are completely pushed together, as shown by the smallest glass stack 3.

Perpendicularly to this end piece 5 a further end piece 6 extends which can extend along the side edges of the glass stack. For controlling the pushed together adjacent parts, recesses 7 and projections 8, respectively, are arranged on the side faces so that the adjacent end pieces 6 can be brought in mesh with each other.

As is seen in fig. 3, these projections and recesses are constructed in the outermost part of the end piece, whereby an unbroken abutment surface for the glass stack in the corner is obtained.

The side faces of these interlocking teeth 7, 8 are moreover straight so that they can be inserted for resting closely on the glass 1. As shown in figs. 1 and 3 this will facilitate the pushing together also in the case of large stacks 2 in that the parts allow a stack thickness almost corresponding to the width of the end piece 5, 6 without bringing the projections 8 out of mesh with the recesses 7.

Moreover it is seen from the drawing, that additional parts can be arranged on the side whereby the protection can be designed to any required number of stacks 2, 3. This presupposes, however, that the corner pads of the two opposite corners of the glass are laterally reversed.

This provides a hitherto unknown flexible packing of glass stacks by means of only one single element which is partly easy to manufacture and partly strong, because it does not have long thin projections which would easily break off.

In the drawing is shown a corner pad which covers the actual corner, but it is within the scope of the invention to design the element so that it covers larger or smaller areas, if so desired. Thus, it is expedient to cast the upper and lower corner pad in one piece to form one single side pad which partly makes the actual packing easier and partly enables packed stacks to be piled on top of each other without in any way damaging these.

If only a package in the form of cover plates resting on the corner pads is required, these plates can be placed on the sides and be tied together for the formation of a compact unit.

Claims

1. Corner pad for the packing of a number of thin plates placed together, such as glass plates, and comprising two identical halves produced of a shock and impact absorbing material, which halves can be assembled around the corners of the plates for the creation of an outer protection, **characterized** in that each half consists of a side piece (4) abutting the side of the outer plate (1), and having two perpendicular end pieces (5, 6) forming a right angle and resting on the ends of the plates (2, 3), said end pieces (6) along their one side edge being provided with recesses (7) and along their opposite side edge with corresponding projections (8).

2. Corner pad according to claim 1, **characterized** in that the recesses (7) and the projections (8) are arranged only along the outermost part of the end pieces (6).

3. Corner pad according to claims 1 and 2, **characterized** in that recesses (7) and projections (8) are merely formed along the side edges of the one side piece (6) whereas the other side piece (5) has unbroken side edges.

4. Corner pad according to claims 1-3, **characterized** in that the end pieces (5, 6) substantially extend along the one side of the side piece (4).

5

10

15

20

25

30

35

40

45

50

55

60

65

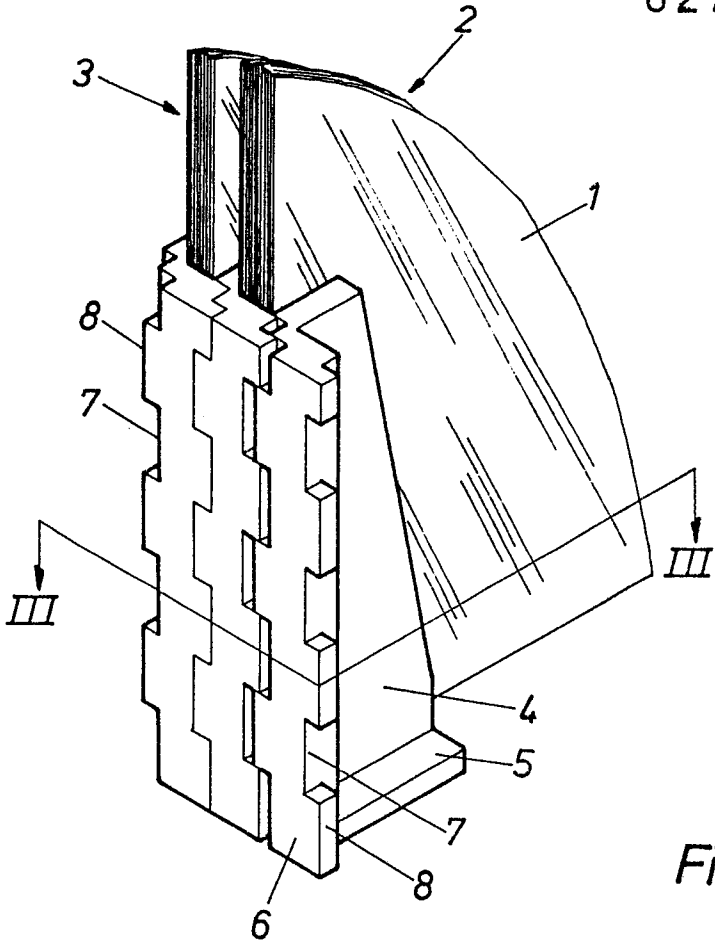

Fig. 1

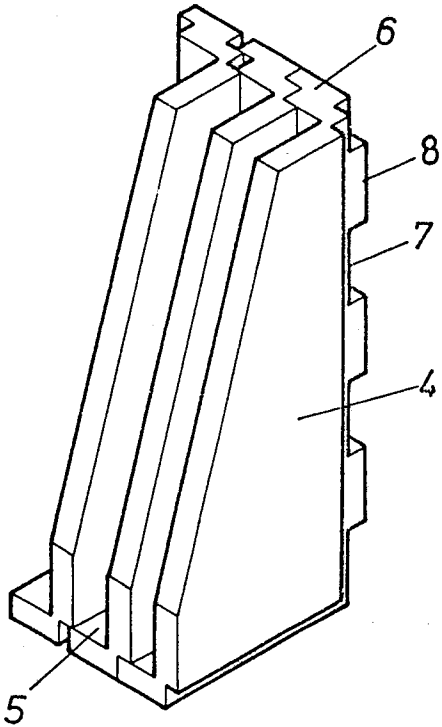

Fig. 2

0270512

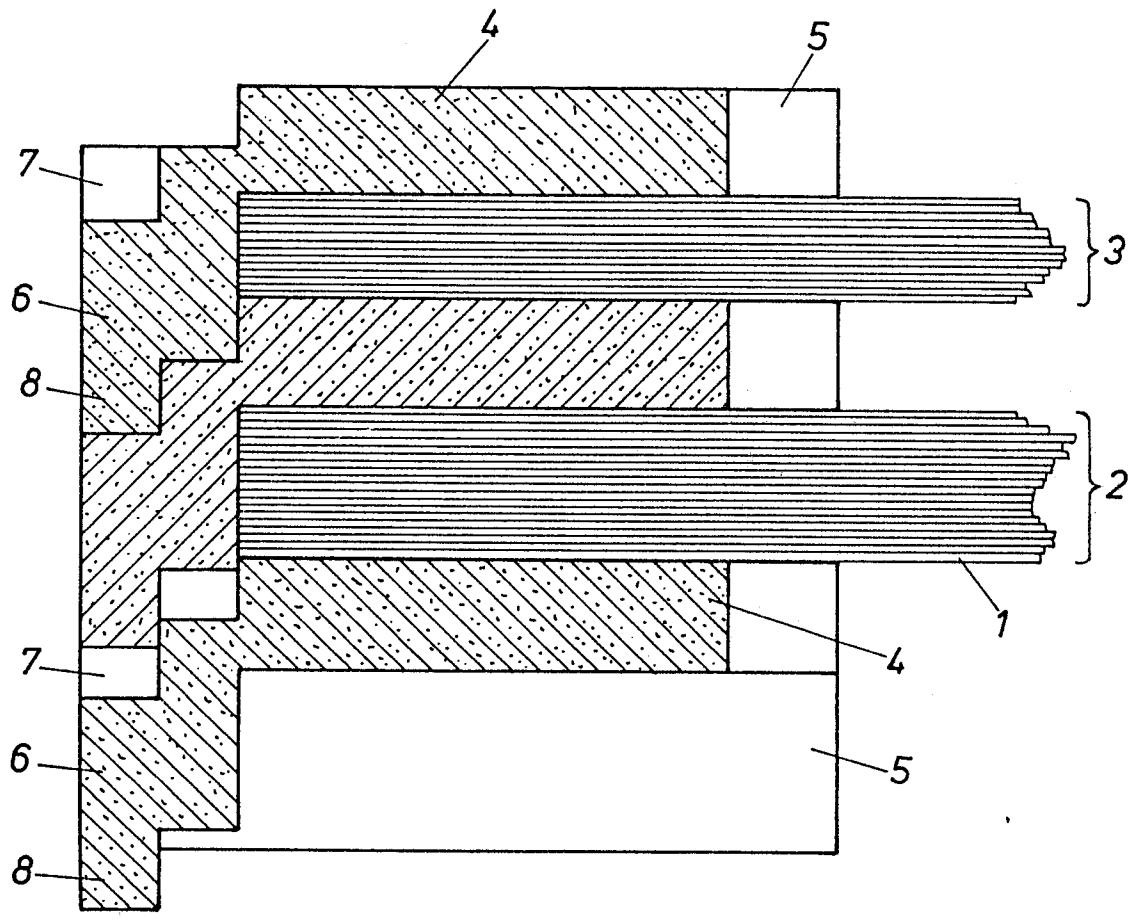

Fig. 3