

(19)



(11)

EP 2 554 716 B1

(12)

EUROPEAN PATENT SPECIFICATION

(45) Date of publication and mention of the grant of the patent:
01.04.2015 Bulletin 2015/14

(51) Int Cl.:
C25D 1/02 (2006.01) **C25D 1/20 (2006.01)**
C25D 7/00 (2006.01)

(21) Application number: **12005057.0**

(22) Date of filing: **09.07.2012**

(54) Method for making a metallic object

Verfahren zur Herstellung metallischer Objekte

Méthode de fabrication d'objets métalliques

(84) Designated Contracting States:
AL AT BE BG CH CY CZ DE DK EE ES FI FR GB GR HR HU IE IS IT LI LT LU LV MC MK MT NL NO PL PT RO RS SE SI SK SM TR

(30) Priority: **01.08.2011 IT VI20110214**

(43) Date of publication of application:
06.02.2013 Bulletin 2013/06

(73) Proprietor: **L.T.C. Caoduro S.r.l.**
36010 Monticello Conte Otto (VI) (IT)

(72) Inventor: **Caoduro, Italo**
36010 Monticello Conte Otto (VI) (IT)

(74) Representative: **Ziliotto, Tiziano**
Studio Ziliotto
Contrada Porta S. Lucia, 48
36100 Vicenza (IT)

(56) References cited:
EP-A1- 0 727 511 **EP-A1- 1 253 221**
US-A- 2 851 331 **US-A- 3 341 432**
US-A- 3 461 045 **US-A- 3 554 874**

EP 2 554 716 B1

Note: Within nine months of the publication of the mention of the grant of the European patent in the European Patent Bulletin, any person may give notice to the European Patent Office of opposition to that patent, in accordance with the Implementing Regulations. Notice of opposition shall not be deemed to have been filed until the opposition fee has been paid. (Art. 99(1) European Patent Convention).

Description

TECHNICAL FIELD OF THE INVENTION

[0001] The present invention falls within the technical field of the manufacturing of metal objects.

[0002] In particular, the present invention relates to a method of manufacturing these objects.

DESCRIPTION OF THE STATE OF THE ART

[0003] Techniques for the manufacturing of metal objects are broadly used in different fields.

[0004] In particular, reference is made herein to metal objects like, for example, accessories for bags, shoes and belts (such as buckles, rings, carabiners, chains, fasteners, etc.); eyewear parts (such as temples, bridges, inserts etc.); zippers; buttons; special watchmaking parts (such as cases, buckles, bracelet meshes, etc.); custom jewellery (such as bracelets, rings, earrings, pendants, etc.); handles (for furniture, doors, refrigerators, etc.); taps and fittings; gift items (such as trays, vases, goblets, teapots, milk jugs, etc.); and technical articles (such as bushings).

[0005] These objects are currently produced using various techniques, such as cast moulding with silicone moulds, die casting, hot pressing, machining plates or blocks, etc.

[0006] They are typically produced using various materials, such as brass and zama alloys, or an alloy of tin and bismuth, copper, aluminium, steel, etc.

[0007] In no case, except in the watch industry, are such objects hollow. Those hollow objects are typically obtained by mechanical techniques to remove the material from a solid piece.

[0008] A first drawback of the above techniques is the fact that to obtain acceptable workability during the manufacturing of objects it is often necessary to use toxic materials like lead.

[0009] Another drawback of the above techniques is the fact that to obtain acceptable workability during the manufacturing of objects it is often necessary to use materials with physical and chemical characteristics which vary over time, as occurs with aluminium for example.

[0010] A further drawback of the above techniques is the fact that to obtain acceptable workability during the manufacturing of objects it is often necessary to use materials with recurrent inherent quality problems, as occurs for example with the zama alloy which, depending on the supplier or the cost, has surface and porosity irregularities that later create problems during galvanizing and finishing treatments, whether for functional or aesthetic purposes.

[0011] Still another drawback of the above techniques is the fact that they do not allow for different weights for an object of the same size, and, in particular, weights commensurate with the requirements for use of the object, such as for the manufacturing of an ornamental pen-

dant with the same aesthetic shape but used for a bracelet or an earring, where in the latter case it must be lighter.

[0012] A further drawback of the above techniques is the need to use different materials to obtain, depending on the final use, different weight characteristics, or even hardness or resistance to abrasion, corrosion, perspiration, temperature, different environmental conditions, etc., such as a buckle with the same aesthetic shape but used in one case for an elegant watch band and for a sports watch band in the other, in which case it must be more resistant and able to sustain extreme conditions of use (for example, sea water, external mechanical forces, etc.). Another drawback of the above techniques, in particular when using die-casting or hot pressing technologies, is the high cost of preparation of the equipment, in particular the moulds, which makes it economical only for the manufacturing of objects on a large scale.

[0013] Examples of methods and/or process of manufacturing hollow metal objects are known from documents US3341432A, US3554874A, EP1253221A1, US2851331A, EP0727511A1 and US3461045A.

[0014] The purpose of the present invention is therefore to overcome these drawbacks. In particular, one object of the present invention is to produce metal objects free of toxic substances.

[0015] Another object of the present invention is to produce a metal object the weight of which can be defined in advance depending on the intended final use.

[0016] A further object of the present invention is to produce the same metal object with different weights in a convenient and easy manner compared to the techniques of the known art.

[0017] Yet another object of the present invention is to produce a metal object which, although light, provides the quality and adequate mechanical strength required for subsequent processing and finishing treatments and for its intended final use.

SUMMARY OF THE PRESENT INVENTION

[0018] The present invention is based on the general consideration of manufacturing a metal object by means of electroforming. According to a first embodiment, the present invention relates to a method of manufacturing a metal object according to claim 1.

[0019] The method of manufacturing a metal object comprises the following steps:

- provide a support element comprising at least a portion of conductive material;
- deposit a layer of a coating material suited to create the intended metal object on the aforementioned support element through an electrochemical process.

[0020] Preferably the covering material is a non-precious material.

[0021] Advantageously, the non-precious material

comprises bronze.

[0022] In a preferred embodiment the support element is made of conductive material. In another preferred embodiment the support element comprises non-conductive material.

[0023] Conveniently, the method includes a step in which a conductive material is applied on a support element made of non-conductive material.

[0024] Advantageously, the step of applying a conductive material includes a metallization step.

[0025] Preferably the metallization step comprises a spraying step.

[0026] **According to the present invention** the method of manufacturing a hollow metal object comprises, prior to the step in which the covering material is deposited, is a further step for the electrochemical depositing of a layer of a second conductive material on the support element suited to increase the conductive capacity of the support element itself.

[0027] Preferably the support element comprises a low-melting material.

[0028] In another preferred embodiment the support element comprises a material of the group comprising: wax, resin, low-melting alloys, or combinations thereof.

[0029] **According to the present invention** the method comprises an emptying step of the support element after depositing a layer of covering material on the support element itself through an electrochemical process.

[0030] Advantageously the method comprises, prior to the emptying step, a drilling step to put the support element and the outer environment in communication.

[0031] In a preferred embodiment the emptying step comprises an emptying step carried out by a thermal heating process suited to melt the support element.

[0032] In another preferred embodiment the emptying step comprises an emptying step carried out by chemical means.

[0033] **According to the present invention**, the method comprises an emptying step of the second conductive material after the emptying step of the support element.

[0034] Advantageously, the emptying step of the second conductive material comprises an emptying step carried out by chemical means.

[0035] Preferably, the support element is made by a moulding process.

[0036] In a second aspect, the invention relates to a metal object manufactured with a method as described above.

[0037] Preferably, this object is an object of the group comprising: accessories for bags, shoes, belts, such as buckles, rings, carabiners, chains, fasteners; parts of eyewear, such as temples, bridges, inserts; zippers; buttons; special watchmaking parts, such as cases, buckles, bracelet meshes; costume jewellery, such as bracelets, rings, earrings, pendants; handles such as handles for furniture, doors, refrigerators; taps and fittings; gift items such as trays, vases, goblets, teapots, milk jugs; and

technical articles, such as bushings.

BRIEF DESCRIPTION OF THE DRAWINGS

[0038] Further advantages, objectives and characteristics as well as embodiments of the present invention are defined in the claims and will be further explained by the following description which makes reference to the attached drawings. In particular:

- Figs. 1 to 12 show the various steps of an object manufactured according to a preferred embodiment of the method of the invention;
- Fig. 13 schematically shows a step of an alternative embodiment of the method of the invention;
- Fig. 14 shows the steps of a further phase of the method of the invention;
- Figs. 15 and 16 show two further phases of the method of the invention.

DETAILED DESCRIPTION OF THE PRESENT INVENTION

[0039] Although the present invention is described below with reference to embodiments represented in the drawings, the present invention is not limited to the embodiments described below and shown in the drawings. On the contrary, the embodiments herein described and shown clarify some aspects of the present invention, the purpose of which is defined by the claims.

[0040] The present invention has proven particularly advantageous when applied to hollow non-precious metal objects. However, it should be pointed out that the present invention is not limited to the manufacturing of hollow metal objects. On the contrary, the present invention finds application in all those cases foreseeing the manufacturing of objects including an outer layer of non-precious metal, as will be explained in more detail below.

[0041] With reference to Figs. 1 to 12 a method of manufacturing a metal object according to a preferred embodiment of the invention is described below.

[0042] The explanation below will refer in particular to the manufacturing of a belt buckle 1, shown as an example in Fig. 12.

[0043] It is clear, however, that the method of the invention can be applied for the production of other objects, particularly hollow metal objects such as accessories for bags, shoes and belts (such as buckles, rings, carabiners, chains, fasteners, etc.); eyewear parts (such as temples, bridges, inserts etc.); zippers; buttons; special watchmaking parts (such as cases, buckles, bracelet meshes, etc.); custom jewellery (such as bracelets, rings, earrings, pendants, etc.); handles (for furniture, doors, refrigerators, etc.); taps and fittings; gift items (such as trays, vases, goblets, teapots, milk jugs, etc.); and technical articles (such as bushings). The first steps of the method indicated in Figs. 1 to 3 consist of the manufacturing of a prototype 2, shown in Fig. 4, of the buckle

1 to be manufactured.

[0044] The first step of the method involves the use of a blank piece 3 with appropriate dimensions for the manufacturing of the prototype 2. The blank piece 3 is preferably made of iron. In some alternative embodiments the blank piece may be made of wax, resin, wood or other material suitable for the purpose.

[0045] By appropriate machining of the blank piece 3, shown schematically in Figs. 2 and 3, prototype 2 is manufactured which substantially reproduces the outer shape of the buckle 1 to be obtained. This processing may include, for example, manual processing with tools, as shown in the figures. In alternative embodiments, however, prototype 2 could be achieved using any other technique of a known type, such as for example by rapid prototyping.

[0046] Preferably the dimensions of prototype 2 are smaller with respect to the external shape of the object to obtain, in this case the buckle 1, taking into account the covering layer which will be subsequently applied during the manufacturing process, as better described below.

[0047] Prototype 2 is used for the manufacturing of a mould 4. The manufacturing of the mould 4, shown in its entirety in Figs. 9A-9C, is schematically shown in Figs. 5 to 8.

[0048] Prototype 2 is placed between two rubber discs 5 and 6 which are placed together and maintained in this position by means of suitable locking means.

[0049] The assembly thus formed, shown in Fig. 7, is placed inside a vulcanizing furnace for a preset time interval and at a given temperature.

[0050] Once the vulcanization process is completed, the impressions of the desired prototype are created on the two rubber layers 5 and 6 as shown in Fig. 8, in which the lower disc 6 advantageously shows multiple impressions of the prototype itself, in this case six units. In this embodiment the six impressions are equal to each other for the simultaneous production of six products equal to each other, in this case six buckles. In alternative embodiments these impressions can be different for the manufacturing of corresponding different products.

[0051] The other disc 5, the upper one, will be advantageously a mirror image of the lower disc 6.

[0052] The two discs 5, 6 are ultimately the two half-moulds of the desired mould 4. The method then foresees a moulding step, shown schematically in Figs. 9A to 9C, during which a suitable filler material M is injected inside the two half moulds 5, 6. Preferably, this step takes place by means of a centrifugal injector in which the fill material M is injected inside the mould cavity 4 during a simultaneous rotation of the two half-moulds 5 and 6, as schematically indicated by the arrow of Fig. 9B.

[0053] The fill material M preferably comprises a low-melting alloy, consisting for example of a tin-bismuth alloy, or wax, resin, etc.

[0054] The low-melting alloy preferably has a melting temperature between 135°C and 145°C.

[0055] In alternative embodiments this fill material may be of another type, such as wax, resin, another eutectic alloy etc.

[0056] At the end of this step, as shown in Fig. 9C, after the opening of the mould 4, an intermediate product 7 is obtained, hereinafter referred to as matrix, which has substantially the final shape of buckle 1, even if of smaller size, and which is made of the fill material M.

[0057] The following steps of the method described below refer to a matrix 7 made with a conductor fill material M.

[0058] The case of a matrix 7 made with a non-conductive fill material M, such as resin or wax, will be discussed later in this description.

[0059] In the following step, as shown in Fig. 10, a plurality of matrices 7 are mounted on a rotating frame 8.

[0060] The frame 8 is a part of an electroforming device comprising a tank containing a suitable electrolyte solution in which the matrices 7 held by the frame 8 are immersed.

[0061] The frame 8 imparts a rotation to the matrices 7 around a main axis X as well as advantageously a rotation around the axis Y of each matrix 7. This favours the electroforming step in the electrolyte solution.

[0062] In fact, the following step includes an electroforming step during which a layer of metal material is deposited by electrodeposition on the matrices 7 immersed in the electrolyte solution.

[0063] The composition of the metal layer depends on the elements selected and contained in the electrolyte solution.

[0064] Preferably the electrolyte solution consists of a solution containing copper and another metal, preferably tin, to deposit a layer of a bronze alloy on the matrices 7.

[0065] In alternative embodiments the electrolyte solution may contain different elements, such as for example, only copper, copper/tin/zinc, copper/zinc, etc., so that on the outer surface of the matrices a suitable layer of non-precious metal material is deposited.

[0066] The thickness and distribution of the layer of the metal covering material will depend on the appropriate control of the concentrations of the elements contained in the solution and the control of the duration of the step in question.

[0067] A typical thickness of the layer of metal covering material ranges between 50 and 1000 microns.

[0068] Fig. 11 shows the steps of the electroforming treatment to deposit a bronze metal layer. These steps include the following operations:

- Electrolytic degreasing (step 100);
- Recovery (step 101);
- Demineralization wash (step 102);
- Neutralization (step 103);
- Demineralization wash (step 104);
- Bronze electroforming (step 105);
- Recovery (step 106);
- Demineralization wash (step 107).

[0069] At the end of the electroforming process a second product is obtained, indicated by number 1 in Fig. 12, comprising the matrix 7 and the layer of non-precious metal covering material, preferably brass.

[0070] In the first embodiment of the invention described herein the manufacturing of the buckle 1 can be considered complete after the external finishing treatment of the second product 9, as schematically indicated in Fig. 12 where the second product 9 is polished with a brushing operation to obtain the buckle 1.

[0071] The external finishing treatment can be performed with any other method of the known type, such as by tumbling, polishing, electroplating, etc.

[0072] The physical and/or chemical properties of the buckle 1 of the invention, and in general of any object obtained by the method according to the present invention as described heretofore, are advantageously provided preferably by the metal covering layer obtained during the electroforming step.

[0073] According to the above description of the method of manufacturing of the buckle 1, it is clear how easy it is to modify and/or adapt the physical and/or chemical characteristics of the manufactured object, through the adjustment of the relevant parameters of the electroforming step.

[0074] Therefore, it will be possible to modify the composition of the electrolyte solution to decide which type of metal or particular alloy will compose the covering layer.

[0075] This directly affects the characteristics of the object, such as its hardness, mechanical strength, glossiness, resistance to scratches, salt corrosion, perspiration, etc.

[0076] Again, it will be possible to modify the duration of the electroforming step to manage the thickness of the layer deposited, obtaining the same object with the same external shape with different desired weights depending on the particular use of the object.

[0077] In addition, both the physical and/or chemical characteristics of the final object can be easily established during the design phase of the production cycles, given that the steps, particularly the electroforming, are controllable in a precise manner.

[0078] Advantageously, again, the manufacturing of the final object avoids the use of toxic materials unlike what occurs with the methods of the prior art used to manufacture objects with similar characteristics and/or weight.

[0079] With reference to Figs. 13 and 14, further steps of the method of the invention are described wherein the matrix 7 is manufactured with a non-conductive fill material M, such as resin or wax.

[0080] In this case, the matrix 7 obtained after the moulding step, that is, after the steps shown in Figs. 9A to 9C, and before being mounted on the frame 8 for immersion in the electrolyte solution (Fig. 10), is subjected to a metallization step, schematically indicated in Fig. 13. It is well known that in order to galvanically deposit a

material on an object, that object must have electrical conductivity properties.

[0081] The metallization step creates a layer of conductive material above the non-conductive material composing matrix 7. The metallization process is preferably performed by spraying, as shown in Fig. 13, a conductive layer preferably made of a material containing micro-particles of silver, copper or brass.

[0082] The metallization step is advantageously followed by a pre-electroforming step. This step takes place with one or more metallised matrices 7 mounted on a frame 8, as previously shown in Fig. 10. Before the electroforming step previously described with reference to Fig. 11, the pre-electroforming step is conducted. The pre-electroforming step preferably comprises the galvanic deposition of a layer of copper on the outer surface of the metallised matrix.

[0083] The layer of copper deposited during this step enables a perfectly smooth and shiny surface to be obtained which is also perfectly conductive from the electrical standpoint. This improves the subsequent electroforming step.

[0084] The layer obtained during the pre-electroforming step comprises a thickness ranging preferably between 50 and 100 microns or even more.

[0085] Fig. 14 shows the steps of the pre-electroforming treatment. These steps include the following operations:

- Electrolytic degreasing (step 150);
- Recovery (step 151);
- Demineralization wash (step 152).
- Neutralization (step 153);
- Demineralization wash (step 154).
- Acid copper plating (step 155);
- Recovery (step 156);
- Washing (step 157);
- Drying (step 158).

[0086] With reference to Figs. 15 and 16 further steps of the method of the invention are described below.

[0087] These steps are advantageously carried out on the second product 9 before the finishing step.

[0088] During such further steps of the method of the invention, the second product 9 is subjected to an emptying operation.

[0089] An opening is created on product 9 to put its inner part, consisting of the matrix 7, in communication with the outer environment. This operation preferably comprises a drilling with a tool, as shown in Fig. 15.

[0090] In alternative embodiments that drilling can be carried out using any technique within the reach of the industry.

[0091] In other embodiments, this step can be omitted if the second article 9 obtained in the previous steps of the method already has an open area in which the matrix 7 emerges at the surface.

[0092] Once the opening between the matrix 7 and the

outer environment is available, the matrix 7 of the second product 9 is subjected to the emptying step.

[0093] Fig. 16 shows an emptying step of the second product in which the matrix is made of low-melting material.

[0094] It is essentially a thermal emptying.

[0095] The second product 9 is mounted on a rotating frame 10 inside an emptying furnace 11, closed and kept at a melting temperature T_s , depending on the type of low-melting material constituting the core, for example 350°C.

[0096] Preferably a first static heating step is followed by one or more rotating cycles, or that is, centrifugal cycles, in one direction and then in the opposite direction. The low-melting material melts and flows out of the opening previously made to then be collected on the bottom of the furnace in a special collection basin 12. The centrifugal action contributes to the complete emptying of the low-melting material.

[0097] In an alternative embodiment, the emptying can take place keeping the second product in a furnace in a stationary position, static emptying, advantageously at a melting temperature T_s ' lower than the temperature used for the centrifugal emptying process above.

[0098] The low-melting material melts and flows out of the opening previously made by gravity to be collected in a special basin placed at the bottom of the furnace.

[0099] In a further alternative embodiment, the emptying of the matrix can take place chemically by placing the second product in tanks containing suitable chemicals able to react only with the matrix material and leaving the metal covering layer deposited during the electroforming step unaltered.

[0100] For example, a solution of ferric chloride can be used in the case of a matrix made of copper and a metal covering layer consisting of bronze.

[0101] This process takes place preferably in polypropylene tanks heated with a water bath.

[0102] More preferably, chemical emptying is used in the emptying process of second products that were subjected to pre-electroforming treatments. In fact, in this case the layer deposited during that step, for example a copper layer as previously described, is advantageously and more effectively removed by chemical means. Even more preferably, in this case, the emptying may foresee an initial thermal emptying step for the removal of the low-melting core followed by a second chemical emptying step for the effective removal of the layer deposited during the pre-electroforming step, typically a copper layer.

[0103] Once the emptying step is completed, the final object is substantially hollow, in this case a hollow buckle, comprising a metal layer created during the electroforming step.

[0104] The physical and/or chemical characteristics of the hollow buckle of the invention, and in general of any hollow object manufactured by the method according to the present invention, are advantageously provided pref-

erably by the covering metal layer created during the electroforming step.

[0105] According to the above description of the method of manufacturing a hollow buckle, it is clear how easy it is to modify and/or adapt the physical and/or chemical characteristics of the manufactured object, through the adjustment of the relevant parameters of the electroforming step.

[0106] Therefore, it will be possible to modify the composition of the electrolyte solution to decide which type of metal or particular alloy will compose the hollow object of the invention.

[0107] This directly affects the characteristics of the object, such as its hardness, mechanical strength, glossiness, resistance to scratches, salt corrosion, perspiration, etc.

[0108] Again, it will be possible to modify the duration of the electroforming step to manage the thickness of the deposited layer, obtaining the same object with the same external shape but different desired weights depending on the particular use of the object.

[0109] In addition, both the physical and/or chemical characteristics of the final object can be easily established during the design phase of the production cycles, given that the steps, particularly the electroforming, are controllable in a precise manner. Advantageously, again, the manufacturing of the final object avoids the use of toxic materials unlike what occurs with the methods of the prior art used to manufacture objects with similar characteristics and/or weight. Therefore, it is demonstrated that the present invention described above achieves the intended objectives. In particular, the present invention overcomes the problems related to the manufacturing of hollow metal objects with the current state of the art. While the present invention was described with reference to particular embodiments of the method shown in the figures, it should be noted that the present invention is not limited to the particular embodiments shown and described above. On the contrary, further embodiments of the method of manufacturing described fall within the scope of the present invention, which is defined by the claims.

45 Claims

1. Method for making a hollow metal object (1), said method comprising the following steps:

- preparing a supporting element (7) comprising at least an outer layer of an electrically conductive material;
- a step of depositing a layer of a covering material suited to obtain said metal object (1) on said supporting element (7) through an electrochemical process;
- a step in which said supporting element (7) is emptied, after said step of deposition of a layer

of covering material on said supporting element (7) through an electrochemical process;

characterized in that said method further comprises:

- a further step of depositing a layer of a second conductive material on said supporting element (7) through an electrochemical process in order to realize a smooth, shiny and electrically conductive surface, said further step of depositing a layer of a second conductive material being performed before said step of depositing a layer of a covering material;
 - a step of emptying out said second conductive material, after said step of emptying said supporting element (7).
2. Method according to claim 1), **characterized in that** said covering material is a non-precious material. 20
 3. Method according to claim 1), **characterized in that** said non-precious material comprises bronze. 20
 4. Method according to claim 1), **characterized in that** said supporting element (7) is entirely made of a conductive material. 25
 5. Method according to any of the claims from 1) to 3), **characterized in that** said supporting element (7) comprises a non-conductive material. 30
 6. Method according to claim 5), **characterized in that** it comprises a step of applying said at least an outer layer of an electrically conductive material to said supporting element (7) comprising a non-conductive material. 35
 7. Method according to any of the preceding claims, **characterized in that** said supporting element (7) comprises a low-melting material. 40
 8. Method according to claim 7), **characterized in that** said emptying step of said supporting element comprises a step of emptying through a thermal heating process suited to melt said supporting element (7). 45
 9. Method according to claim 8), **characterized in that** said emptying step comprises a step in which the emptying operation is performed through a chemical process. 50
 10. Method according to any of the preceding claims, **characterized in that** said layer of said second conductive material is a layer of copper. 55
 11. Method according to any of the preceding claims, **characterized in that** said step of emptying out said

second conductive material is performed through a chemical process.

5 Patentansprüche

1. Methode zur Herstellung eines hohlen Metallobjekts (1), wobei die besagte Methode folgende Schritte umfasst:

- Vorbereitung eines Stützelements (7), wenigstens eine äußere Schicht aus einem elektrisch leitfähigen Material umfassend;
- einen Schritt der Ablagerung einer Schicht aus einem Überzugmaterial auf dem besagten Stützelement (7) durch einen elektrochemischen Prozess, dazu geeignet, das besagte Metallobjekt (1) zu erzielen;
- einen Schritt, in dem das besagte Stützelement (7) entleert wird, nach dem besagten Schritt der Ablagerung einer Schicht aus Überzugmaterial auf dem besagten Stützelement (7) durch einen elektrochemischen Prozess;

dadurch **gekennzeichnet**, dass die besagte Methode des Weiteren Folgendes umfasst:

- einen weiteren Schritt der Ablagerung einer Schicht eines zweiten, leitfähigen Materials auf dem besagten Stützelement (7) durch einen elektrochemischen Prozess, um eine glatte, glänzende und elektrisch leitfähige Oberfläche zu erzielen, wobei der besagte weitere Schritt der Ablagerung einer Schicht eines zweiten, leitfähigen Materials vor dem besagten Schritt der Ablagerung eines Überzugmaterials vorgenommen wird;
- einen Schritt der Entleerung des besagten zweiten, leitfähigen Materials nach dem besagten Schritt der Entleerung des besagten Stützelements (7).

2. Methode gemäß Patentanspruch 1), dadurch **gekennzeichnet**, dass das besagte Überzugmaterial kein edles Material ist.
3. Methode gemäß Patentanspruch 1), dadurch **gekennzeichnet**, dass das besagte, nicht edle Material Bronze umfasst.
4. Methode gemäß Patentanspruch 1), dadurch **gekennzeichnet**, dass das besagte Stützelement (7) vollständig aus einem leitfähigen Material gefertigt ist.
5. Methode gemäß eines jeden der Patentansprüche von 1) bis 3), dadurch **gekennzeichnet**, dass das besagte Stützelement (7) ein nicht leitfähiges Mate-

rial umfasst.

6. Methode gemäß Patentanspruch 5), dadurch **gekennzeichnet**, dass sie einen Schritt des Auftrags der wenigstens einen äußeren Schicht eines elektrisch leitfähigen Materials auf dem besagten, ein nicht leitfähiges Material umfassenden Stützelement (7) umfasst; 5
7. Methode gemäß eines jeden der vorstehenden Patentansprüche, dadurch **gekennzeichnet**, dass das besagte Stützelement (7) ein niedrig schmelzendes Material umfasst. 10
8. Methode gemäß Patentanspruch 7), dadurch **gekennzeichnet**, dass der besagte Entleerungsschritt des besagten Stützelements einen Schritt der Entleerung durch einen thermischen Heizprozess umfasst, der geeignet ist, das besagte Stützelement (7) zu schmelzen. 20
9. Methode gemäß Patentanspruch 8), dadurch **gekennzeichnet**, dass der besagte Entleerungsschritt einen Schritt umfasst, in dem der Entleerungsvorgang durch einen chemischen Prozess erfolgt. 25
10. Methode gemäß eines jeden der vorstehenden Patentansprüche, dadurch **gekennzeichnet**, dass die besagte Schicht des besagten, leitfähigen Materials eine Kupferschicht ist. 30
11. Methode gemäß eines jeden der vorstehenden Patentansprüche, dadurch **gekennzeichnet**, dass der besagte Schritt der Entleerung des besagten, zweiten leitfähigen Materials durch einen chemischen Prozess erfolgt. 35

Revendications

1. Méthode pour la réalisation d'un objet métallique creux (1), ladite méthode comprenant les phases suivantes : 40
- préparation d'un élément de support (7) comprenant au moins une couche extérieure d'un matériau électriquement conducteur ; 45
 - dépôt d'une couche d'un matériau de couverture indiqué pour obtenir ledit objet métallique (1) sur ledit élément de support (7) au moyen d'un processus électrochimique ; 50
 - vidage dudit élément de support (7), après ladite phase de dépôt d'une couche de matériau de couverture sur ledit élément de support (7) au moyen d'un processus électrochimique ; 55

caractérisée en ce que ladite méthode comprend en outre :

- une phase ultérieure de dépôt d'une couche d'un deuxième matériau conducteur sur ledit élément de support (7) au moyen d'un processus électrochimique de façon à réaliser une surface lisse, brillante et électriquement conductrice, ladite phase ultérieure de dépôt d'une couche d'un deuxième matériau conducteur étant exécutée avant ladite phase de dépôt d'une couche de matériau de couverture ;
- une phase de vidage dudit deuxième matériau conducteur, après ladite phase de vidage dudit élément de support (7).

2. Méthode selon la revendication 1), **caractérisée en ce que** ledit matériau de couverture est un matériau non précieux.
3. Méthode selon la revendication 1), **caractérisée en ce que** ledit matériau non précieux comprend du bronze.
4. Méthode selon la revendication 1), **caractérisée en ce que** ledit élément de support (7) est complètement réalisé en un matériau conducteur.
5. Méthode selon l'une quelconque des revendications de 1) à 3), **caractérisée en ce que** ledit élément de support (7) comprend un matériau non conducteur.
6. Méthode selon la revendication 5), **caractérisée en ce qu'il** comprend une phase d'application de ladite au moins une couche extérieure d'un matériau électriquement conducteur sur ledit élément de support (7) comprenant un matériau non conducteur.
7. Méthode selon l'une quelconque des revendications précédentes, **caractérisée en ce que** ledit élément de support (7) comprend un matériau à bas point de fusion.
8. Méthode selon la revendication 7), **caractérisée en ce que** ladite phase de vidage dudit élément de support comprend une phase de vidage au moyen d'un processus de chauffage thermique apte à fondre ledit élément de support (7).
9. Méthode selon la revendication 8), **caractérisée en ce que** ladite phase de vidage comprend une phase dans laquelle l'opération de vidage est exécutée au moyen d'un processus chimique.
10. Méthode selon l'une quelconque des revendications précédentes, **caractérisée en ce que** ladite couche dudit deuxième matériau conducteur est une couche de cuivre.
11. Méthode selon l'une quelconque des revendications précédentes, **caractérisée en ce que** ladite phase

de vidage dudit deuxième matériau conducteur est exécutée au moyen d'un processus chimique.

5

10

15

20

25

30

35

40

45

50

55



FIG. 1

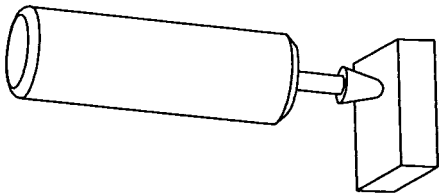

FIG. 2

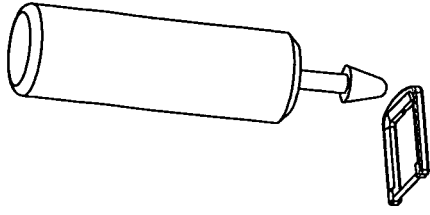

FIG. 3

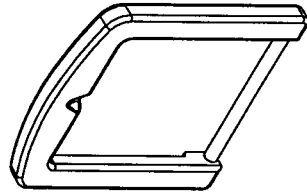

FIG. 4

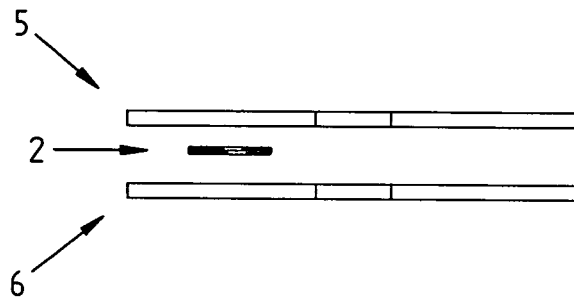

FIG. 5

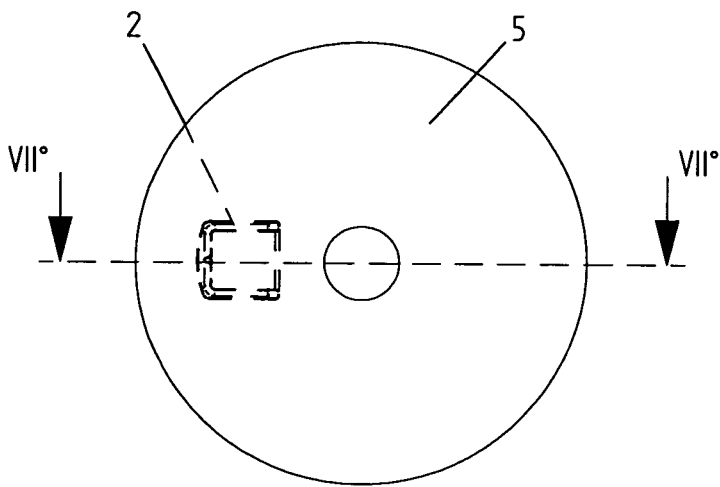

FIG. 6

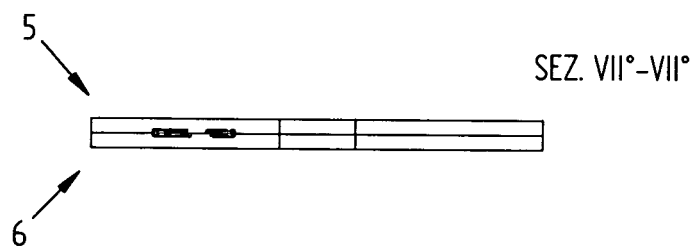

FIG. 7

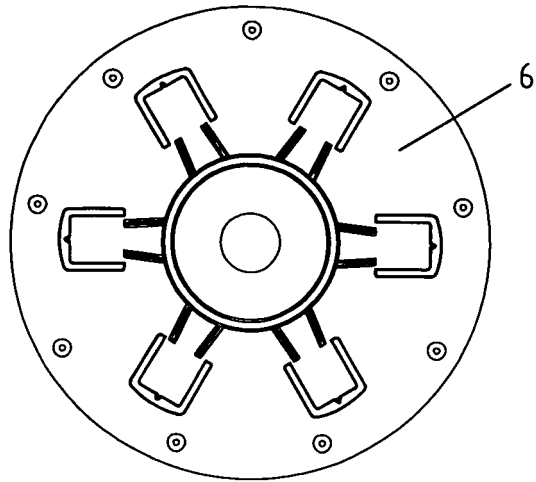

FIG. 8

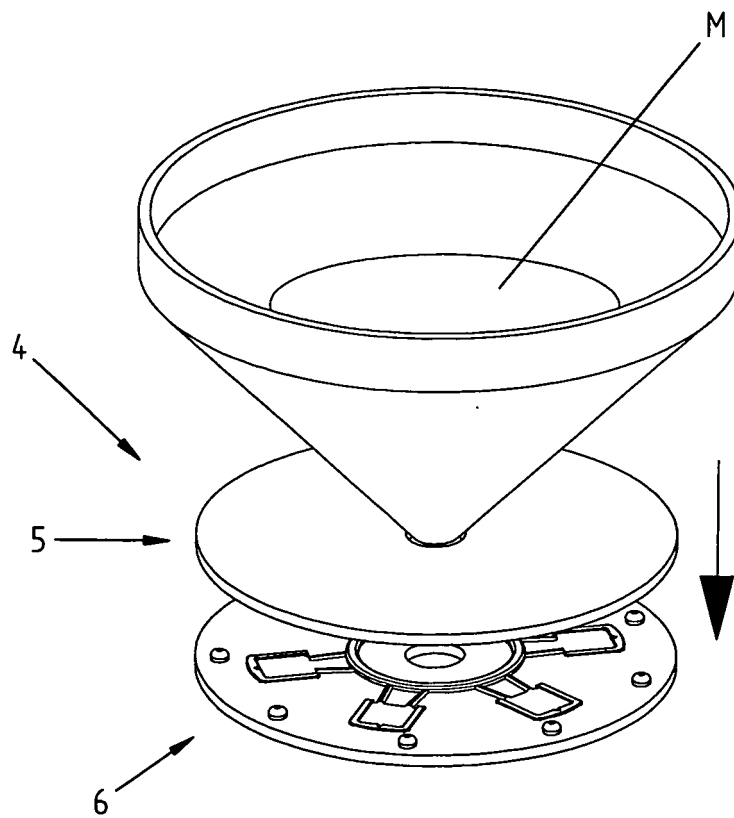

FIG. 9A

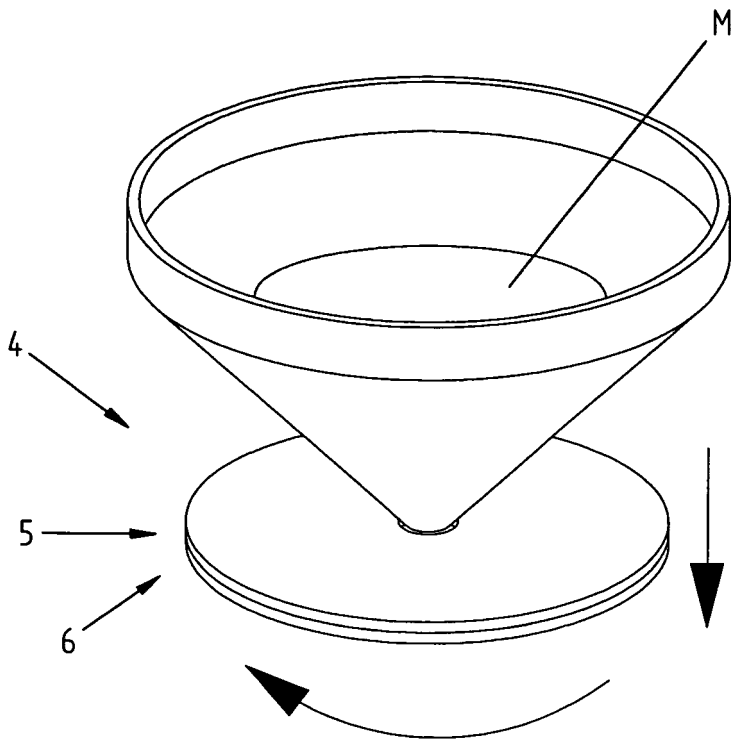

FIG. 9B

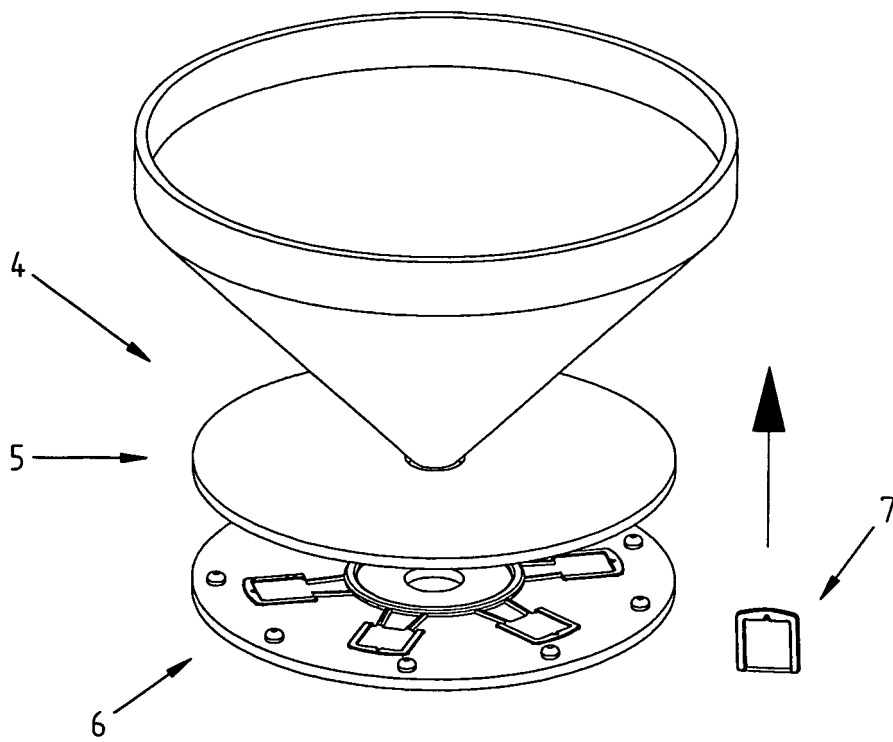

FIG. 9C

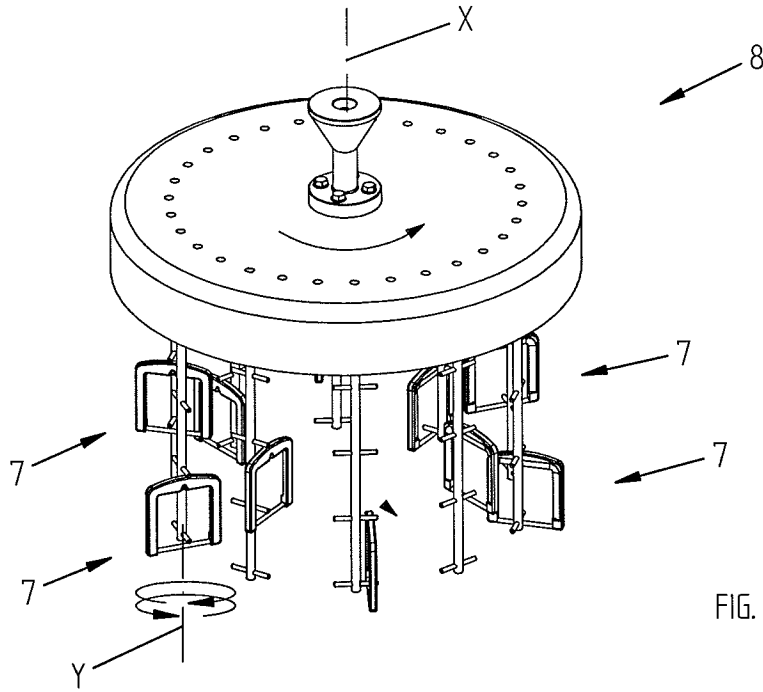

FIG. 10

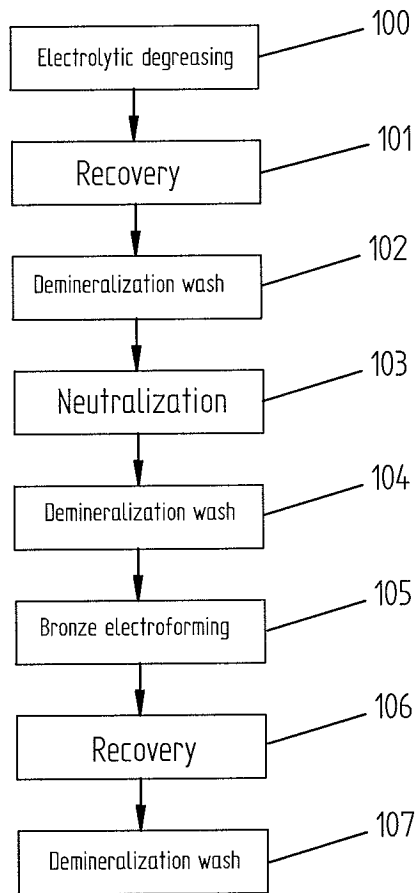

FIG. 11

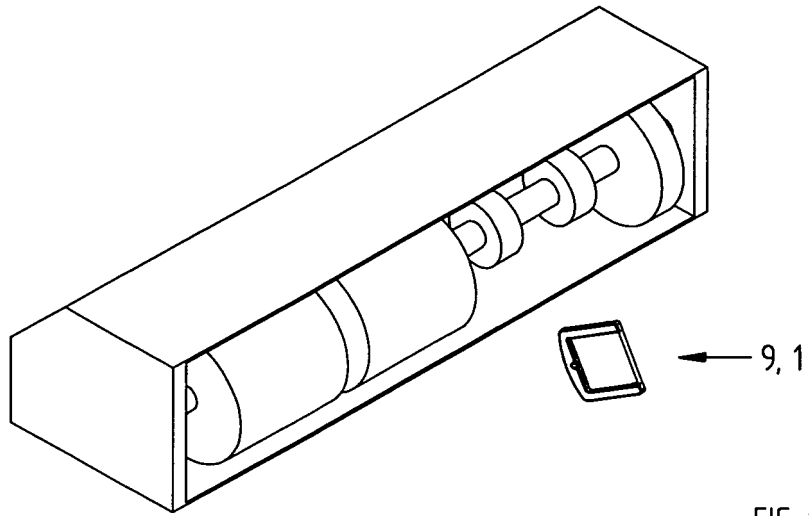

FIG. 12

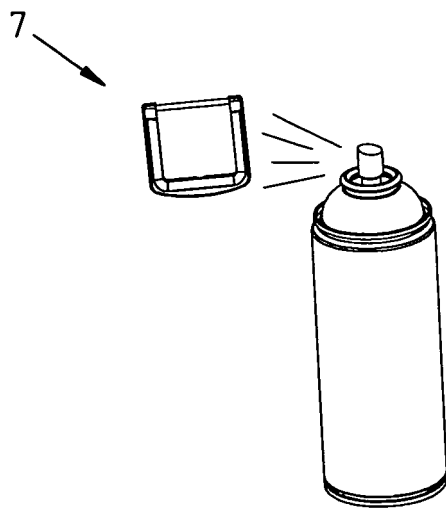

FIG. 13

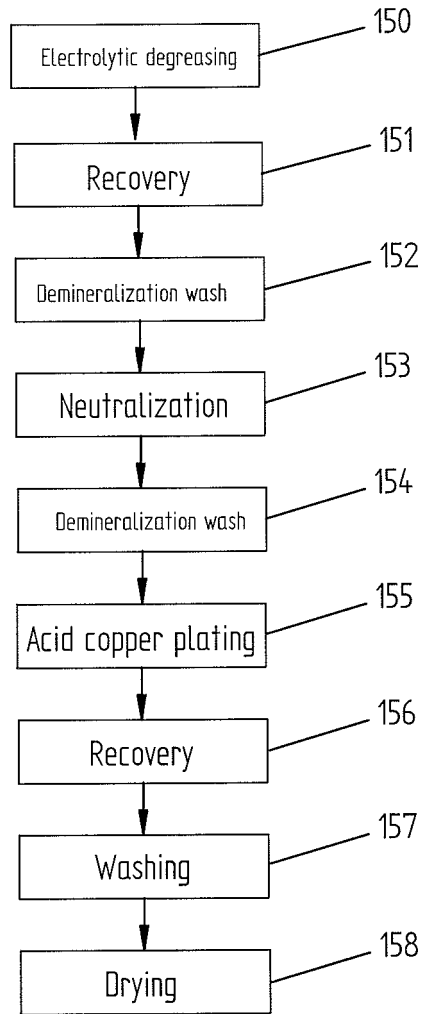

FIG. 14

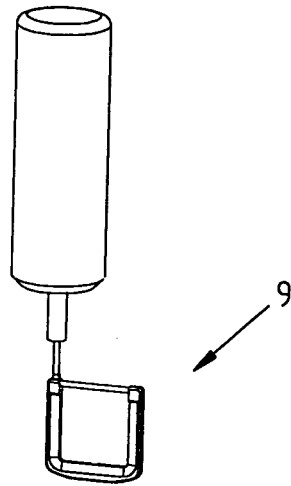

FIG. 15

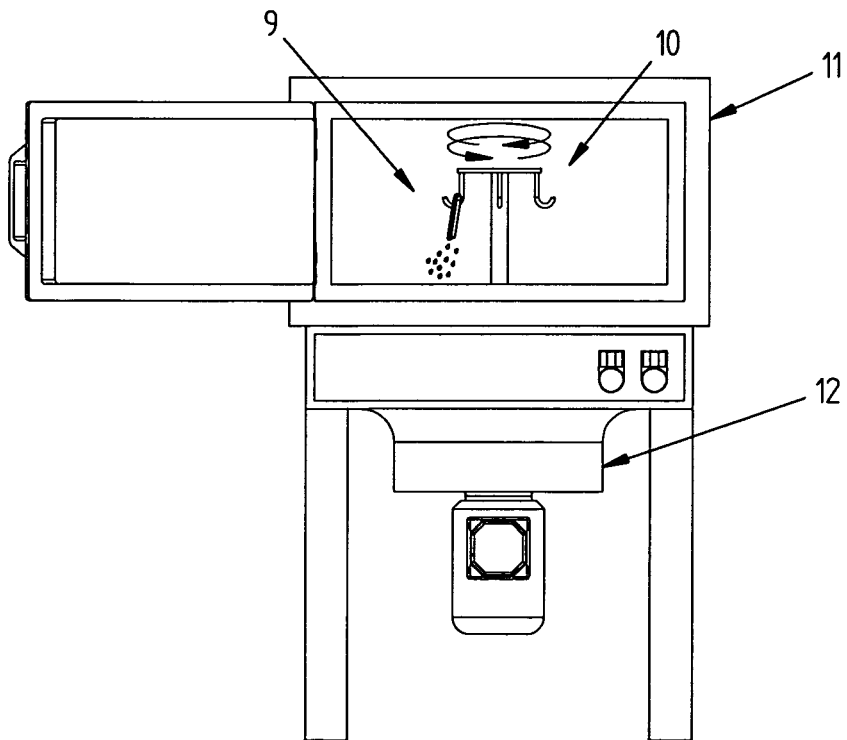

FIG. 16

REFERENCES CITED IN THE DESCRIPTION

This list of references cited by the applicant is for the reader's convenience only. It does not form part of the European patent document. Even though great care has been taken in compiling the references, errors or omissions cannot be excluded and the EPO disclaims all liability in this regard.

Patent documents cited in the description

- US 3341432 A [0013]
- US 3554874 A [0013]
- EP 1253221 A1 [0013]
- US 2851331 A [0013]
- EP 0727511 A1 [0013]
- US 3461045 A [0013]