



US 20140284292A1

(19) **United States**  
(12) **Patent Application Publication**  
**Pantel**

(10) **Pub. No.: US 2014/0284292 A1**  
(43) **Pub. Date: Sep. 25, 2014**

(54) **PHOTOVOLTAIC PANEL SUPPORT WITH WHEELS**

(52) **U.S. Cl.**  
CPC *F24J 2/36* (2013.01); *F24J 2/5239* (2013.01);  
*F24J 2/523* (2013.01)  
USPC ..... **211/85.8; 211/41.1**

(71) Applicant: **Richard Pantel**, Round Hill, VA (US)

(72) Inventor: **Richard Pantel**, Round Hill, VA (US)

(21) Appl. No.: **14/219,595**

(57) **ABSTRACT**

(22) Filed: **Mar. 19, 2014**

**Related U.S. Application Data**

(60) Provisional application No. 61/852,660, filed on Mar. 19, 2013, provisional application No. 61/964,822, filed on Jan. 16, 2014.

**Publication Classification**

(51) **Int. Cl.**  
*F24J 2/36* (2006.01)  
*F24J 2/52* (2006.01)

A photovoltaic panel support system is provided. The panel support may include a surface frame and a support frame. The surface frame may be mounted to a surface. The support frame may be attached to the surface frame and may support photovoltaic panels. The present invention may further include a plurality of vertical posts. Each vertical post may include a top end and a bottom end. The top end may connect with the support frame and the bottom end is supported by at least one of the surface frame and the surface. At least a portion of the plurality of vertical posts includes a wheel on the bottom end.

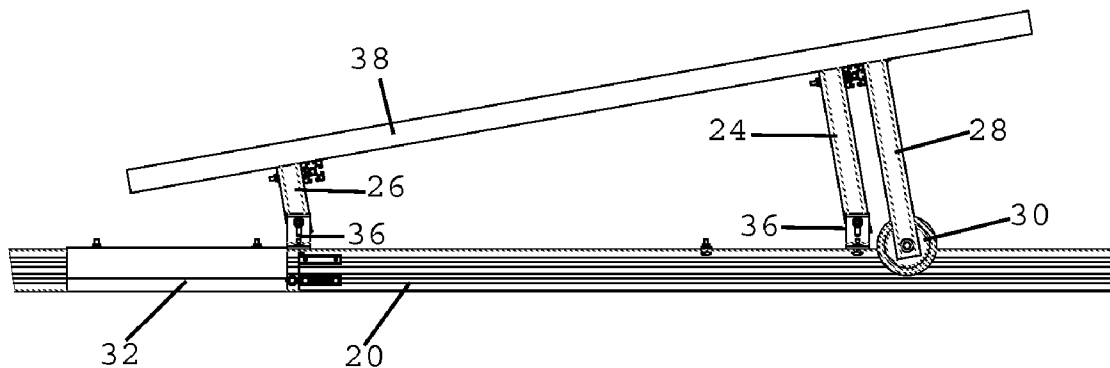

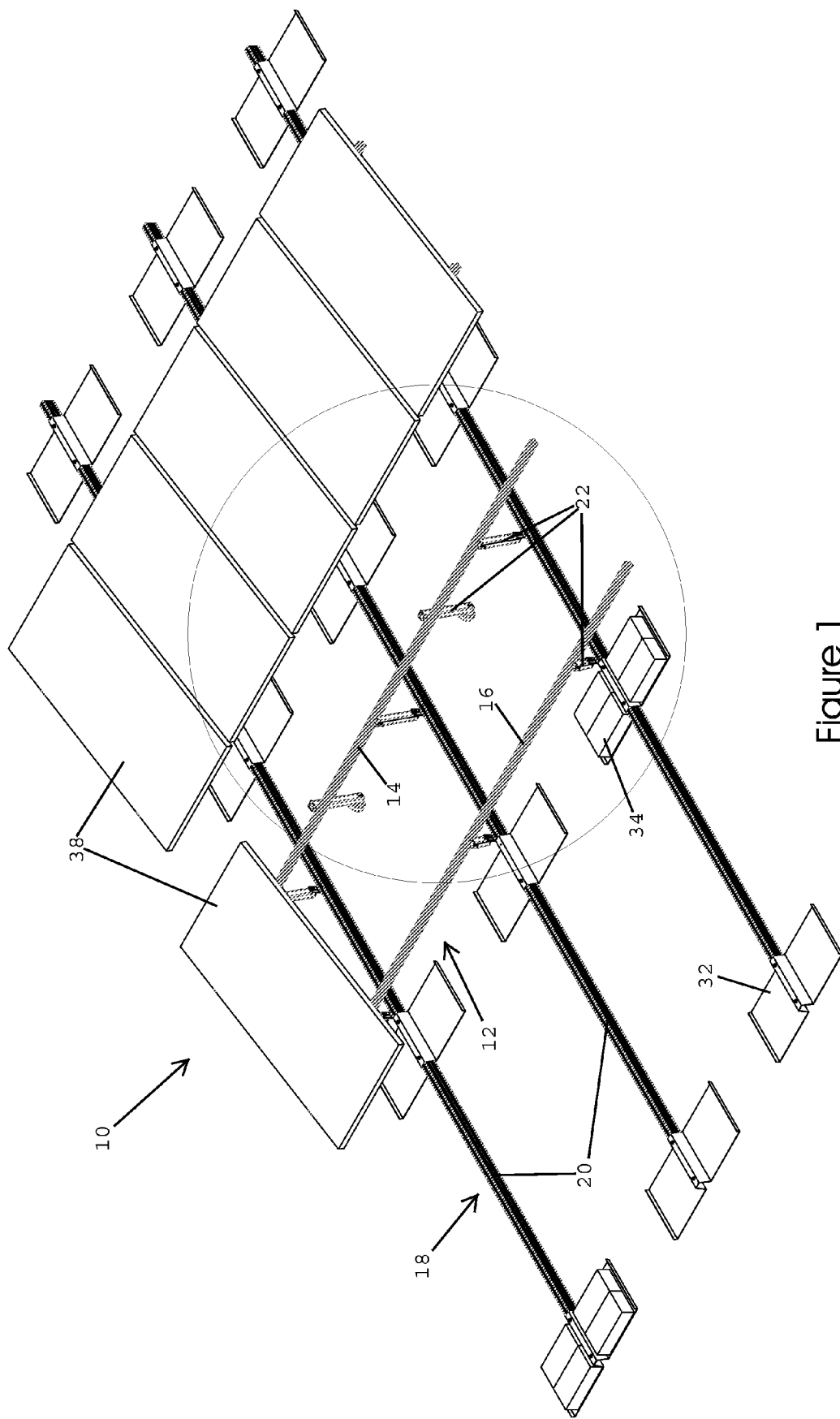

Figure 1

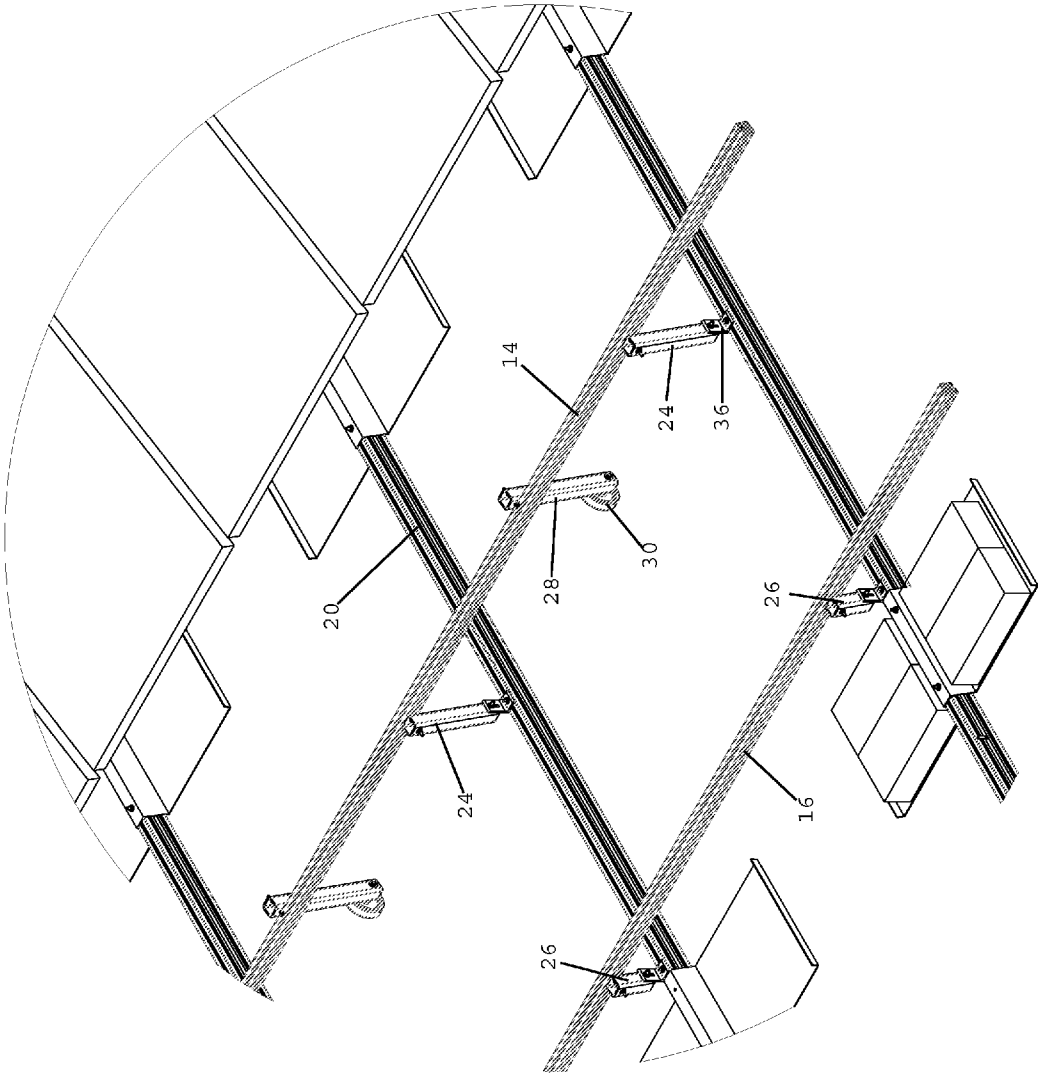

Figure 1A

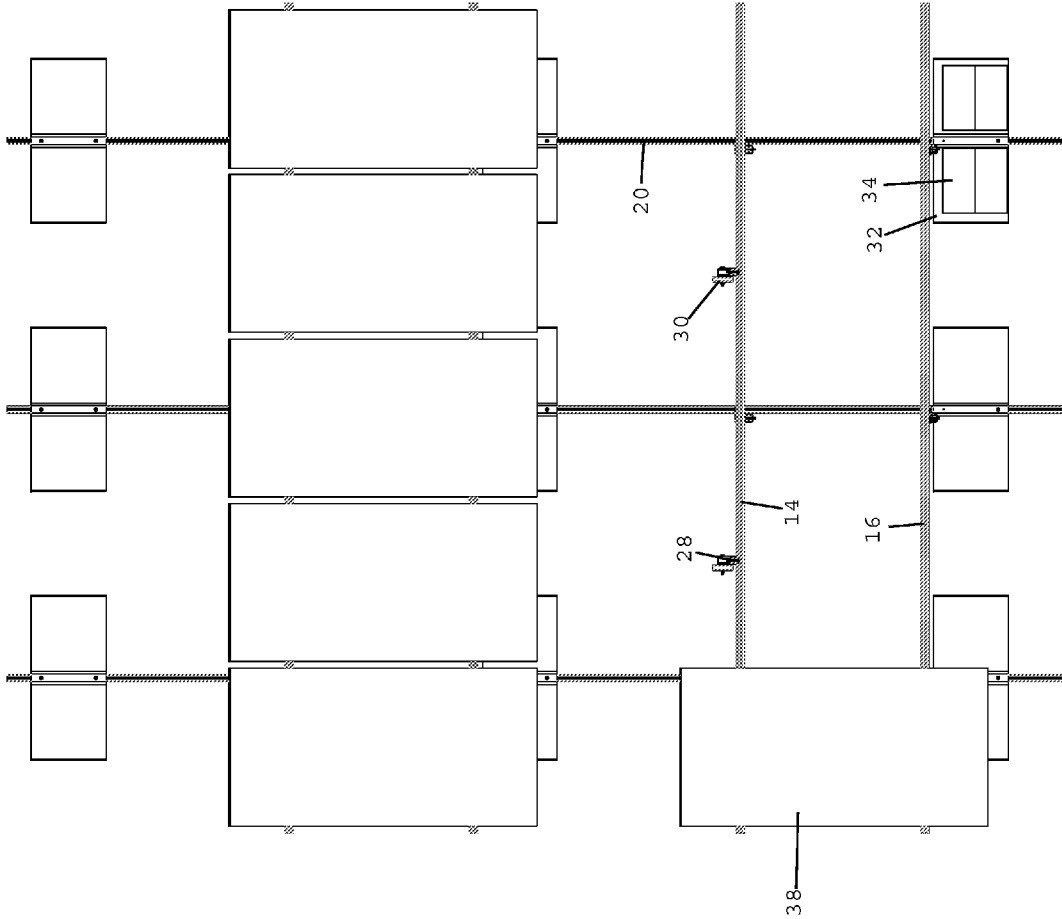

Figure 2

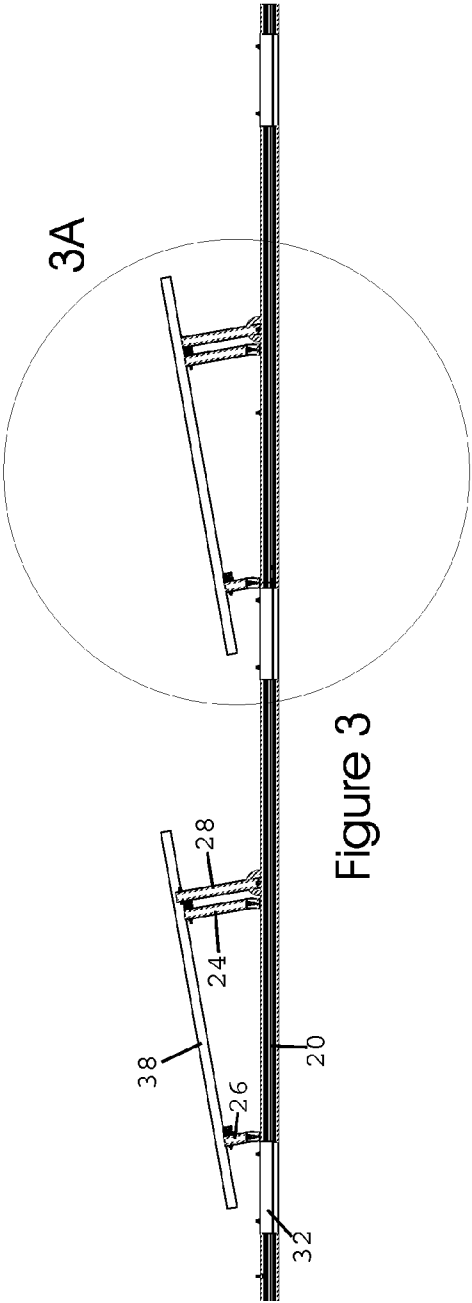

Figure 3

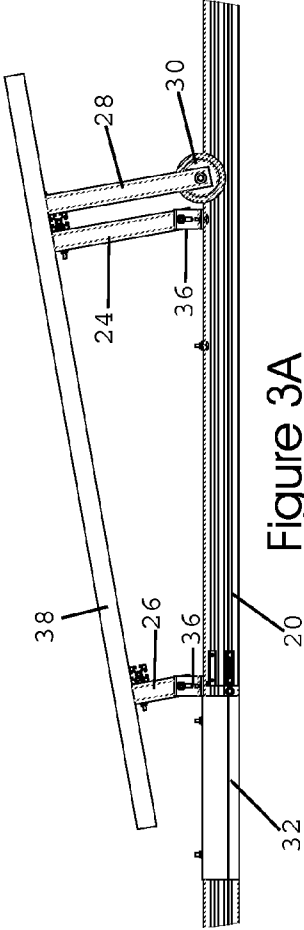

Figure 3A

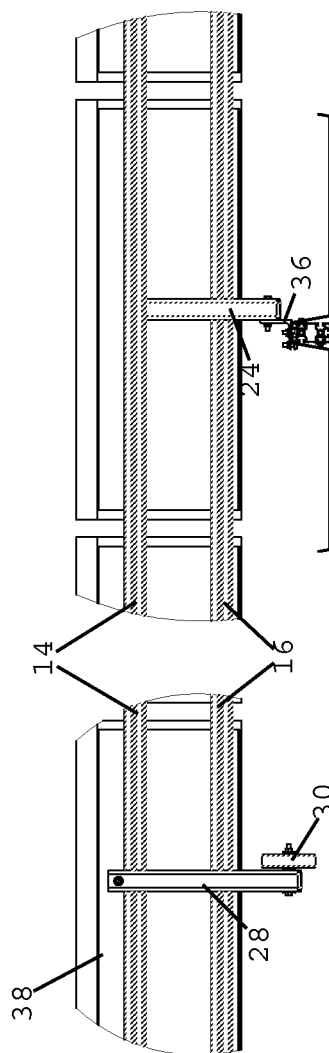
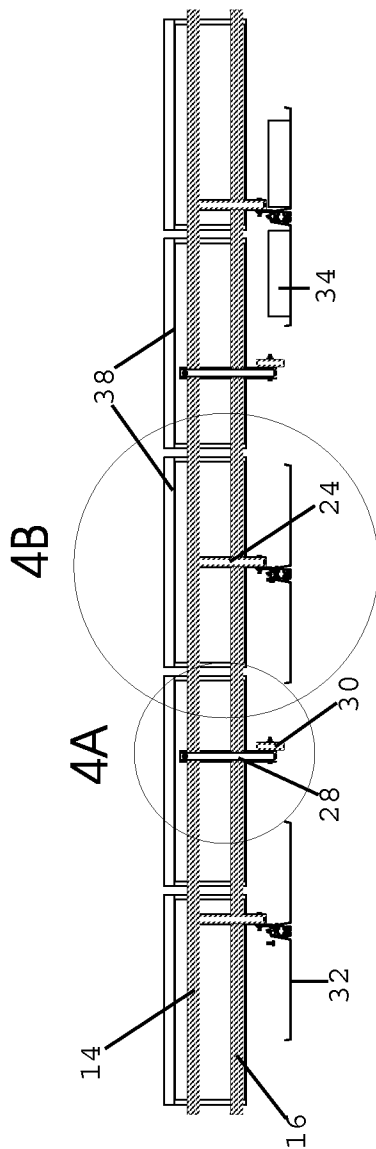

Figure 4B

Figure 4A

## PHOTOVOLTAIC PANEL SUPPORT WITH WHEELS

### CROSS-REFERENCE TO RELATED APPLICATION

[0001] This application claims the benefit of priority of U.S. provisional application No. 61/852,660, filed Mar. 19, 2013, and U.S. provisional application No. 61/964,822, filed Jan. 16, 2014, the contents of which are herein incorporated by reference.

### BACKGROUND OF THE INVENTION

[0002] The present invention relates to photovoltaic panel support and, more particularly, to a photovoltaic panel support with wheels.

[0003] A photovoltaic solar array is a set of solar photovoltaic modules electrically connected and mounted on supporting structures. A photovoltaic module, commonly called a "solar panel", is a packaged, connected assembly of solar cells. The solar module can be used as a component of a larger photovoltaic system to generate and supply electricity in commercial and residential applications. Generally, support structures are mounted to roofs of commercial and residential buildings. The roofs may need to be repaired occasionally and the solar panels may need to be temporarily removed. Currently, the panel itself must be removed from the support structure and the support structure itself may also need to be disassembled, which is time consuming and difficult.

[0004] As can be seen, there is a need for a more versatile and lower cost support structure for photovoltaic panels.

### SUMMARY OF THE INVENTION

[0005] In one aspect of the present invention, a device for securing at least one panel comprises: a surface frame mounted to a surface; a support frame attached to the surface frame and configured to support a photovoltaic panel; and a plurality of vertical posts each comprising a top end and a bottom end, wherein the top end connects with the support frame and the bottom end is supported by at least one of the surface frame and the surface, wherein at least a portion of the plurality of vertical posts each comprises a wheel at the bottom end.

[0006] These and other features, aspects and advantages of the present invention will become better understood with reference to the following drawings, description and claims.

### BRIEF DESCRIPTION OF THE DRAWINGS

[0007] FIG. 1 is a perspective view of multiple panel supports interconnected;

[0008] FIG. 1A is a detail perspective view of a single panel support of FIG. 1;

[0009] FIG. 2 is a top view of the multiple panel supports;

[0010] FIG. 3 is a side view of the multiple panel supports;

[0011] FIG. 3A is a detail side view of a single panel support of FIG. 3;

[0012] FIG. 4 is a back view of the multiple panel supports;

[0013] FIG. 4A is a detail back view of a vertical wheel post of FIG. 4; and

[0014] FIG. 4B is a detail back view of an upper vertical post of FIG. 4.

### DETAILED DESCRIPTION OF THE INVENTION

[0015] The following detailed description is of the best currently contemplated modes of carrying out exemplary embodiments of the invention. The description is not to be taken in a limiting sense, but is made merely for the purpose of illustrating the general principles of the invention, since the scope of the invention is best defined by the appended claims.

[0016] The present invention includes a solar photovoltaic (PV) rack mounting system that incorporates a modular design within a rigid interconnected framework. The present invention further includes wheeled supports. Therefore, the present invention may significantly reduce solar installation time and costs, permit quick and easy removal of the PV equipment to accommodate roof repairs, result in a lower overall system weight load, and provide a lower cost racking system as compared to conventional systems. Given high costs of installations, lowering equipment costs and installation time is critical to wide-scale adoption of solar energy systems.

[0017] Referring to FIGS. 1 through 4, the present invention includes a panel support 10. The panel support 10 may include a surface frame 18 and a support frame 12. The surface frame 18 may be mounted to a surface. The support frame 12 may be attached to the surface frame 18 and may support photovoltaic panels 38. The present invention may further include a plurality of vertical posts 22. Each vertical post 22 may include a top end and a bottom end. The top end may connect with the support frame 12 and the bottom end is supported by at least one of the surface frame 18 and the surface. At least a portion of the plurality of vertical posts 22 includes a wheel 30 on the bottom end.

[0018] In certain embodiments, the surface frame 18 may include a plurality of floor rails 20 mounted to the surface, such as a roof or the ground. The floor rails 20 may be parallel relative to one another. The floor rails 20 are typically oriented in a North to South direction. In certain embodiments, the floor rails 20 may be supported by pre-assembled support pads (feet).

[0019] In certain embodiments, the support frame 12 may include at least a first support rail 14 and a second support rail 16. The first support rail 14 and the second support rail 16 may be substantially parallel to one another and may be substantially perpendicular to the floor rails 20. The first support rail 14 and the second support rail 16 are typically oriented in an East to West direction. The first support rail 14 and the second support rail 16 may be made of aluminum extrusions, steel beams, or other rigid materials, such as fiberglass, with structural characteristics sufficient to resist anticipated environmental loading. The support frame 12 may secure between one and around six photovoltaic or thermal solar module panels 38 assembled edge to edge in a linear orientation.

[0020] The plurality of vertical posts 22 may include a plurality of upper vertical posts 24, a plurality of lower vertical posts 26, and at least one vertical wheeled post 28. In certain embodiments, the upper vertical posts 24 may connect the first support rail 14 to the floor rails 20. The lower vertical posts 26 may connect the second support rail 16 to the floor rails 20. In certain embodiments, the upper vertical posts 24 may have a greater length than the lower vertical posts 26, so that the support panels 38 may be oriented at an angle. The vertical wheeled post 28 includes the wheel 30. The top of the vertical wheeled post 28 may be connected to the first support

rail 14 and the wheel 30 may rest on the surface. The vertical wheeled post 28 may be oriented in between the upper vertical posts 24.

[0021] As illustrated in the Figures, the panel support 10 may include three floor rails 20 oriented substantially parallel to one another. Three upper vertical posts 24 may connect the first support rail 14 to the three floor rails 20. Three lower vertical posts 26 may connect the second support rail 16 to the three floor rails 20. The vertical posts 22 may be connected with the floor rails 20 by L-brackets 36. The panels 38 may be mounted to the first support rail 14 and the second support rails 16 by clamps. There may be two wheeled vertical posts 28, each positioned in between the upper vertical posts 24, and thereby in between the floor rails 20.

[0022] In certain embodiments, multiple panel supports 10 may be interconnected. As illustrated in FIG. 1, a second surface frame 18 of a second panel support 10 may include a second plurality of floor rails 20 running end to end with the plurality of floor rails 20 of the first panel support 10. In such embodiments, the end to end floor rails 40 may connect together by a plurality of splices. To further secure the floor rails 30 together, trays 32 may be used to ground the multiple panel supports 10 together. In certain embodiments, ballasts 34 may be used to add additional weight to the trays 32, and thereby further secure the panel supports 10 to the surface.

[0023] As mentioned above, the present invention may include two additional vertical posts 22 with wheels 30 attached to the first support rail 14. The wheels 30 are in contact with the surface, such as the roof or ground. Therefore, a user may manually lift the support frame 12 (with the panels 38 attached) by lifting the second support rail 16. The user may then quickly move the entire support frame 12 similar to moving a wheel barrow, to clear roof space for repairs and replacement. After the repairs or replacement has been completed, the support frame 12 may be easily rolled back into the initial position and the upper vertical posts 24 and lower vertical posts 26 may be reattached to the floor rails 20.

[0024] It should be understood, of course, that the foregoing relates to exemplary embodiments of the invention and that modifications may be made without departing from the spirit and scope of the invention as set forth in the following claims.

What is claimed is:

- 1. A device for securing at least one panel comprising:
  - a surface frame mounted to a surface;
  - a support frame attached to the surface frame and configured to support a photovoltaic panel; and
  - a plurality of vertical posts each comprising

a top end and a bottom end, wherein the top end connects with the support frame and the bottom end is supported by at least one of the surface frame and the surface,

wherein at least a portion of the plurality of vertical posts each comprises a wheel at the bottom end.

2. The device of claim 1, wherein the surface frame comprises a plurality of floor rails mounted to the surface, wherein the plurality of floor rails is substantially parallel to one another.

3. The device of claim 2, wherein the support frame comprises at least a first support rail and a second support rail, wherein the first support rail and the second support rail run substantially parallel to one another and substantially perpendicular to the plurality of floor rails.

4. The device of claim 3, wherein the plurality of vertical posts comprises a plurality of upper vertical posts, a plurality of lower vertical posts, and at least one vertical wheel post.

5. The device of claim 4, wherein the plurality of upper vertical posts connects the first support rail to the plurality of floor rails.

6. The device of claim 5, wherein the plurality of lower vertical posts connects the second support rail to the plurality of floor rails.

7. The device of claim 6, wherein the at least one vertical wheel post comprises the wheel, wherein the top of the at least one vertical wheel post is connected to the first support rail, and the wheel is resting on the surface.

8. The device of claim 7, wherein the at least one vertical wheel post is oriented in between the plurality of upper vertical posts.

9. The device of claim 6, wherein the plurality of upper vertical posts has a greater length than the plurality of lower vertical posts.

10. The device of claim 3, wherein the surface frame runs substantially North to South and the support frame runs substantially East to West.

11. The device of claim 3, further comprising a second surface frame comprising a second plurality of floor rails running end to end with the plurality of floor rails.

12. The device of claim 11, further comprising a plurality of splices and a plurality of trays connecting the second plurality of floor rails to the plurality of floor rails.

13. The device of claim 12, further comprising a plurality of ballasts resting on the plurality of trays.

14. The device of claim 6, further comprising a plurality of L-brackets connecting each of the plurality of upper vertical posts and lower vertical posts to the surface frame.

15. The device of claim 1, further comprising a plurality of clamps attaching the photovoltaic panel to the support frame.

\* \* \* \* \*