



(51) International Patent Classification:

A01N 53/00 (2006.01) A01N 43/30 (2006.01)
A01N 25/10 (2006.01) A01N 25/34 (2006.01)

(21) International Application Number:

PCT/DK2009/050186

(22) International Filing Date:

23 July 2009 (23.07.2009)

(25) Filing Language:

English

(26) Publication Language:

English

(30) Priority Data:

PA 2008 01074 6 August 2008 (06.08.2008) DK

(71) Applicant (for all designated States except US):
VESTERGAARD FRANDSEN SA [CH/CH]; Chemin
Messidor 5-7, CH-1006 Lausanne (CH).

(72) Inventors; and

(75) Inventors/Applicants (for US only): FRANDSEN,
Mikkel Vestergaard [DK/CH]; Rue de Mercerie 14,
CH-1003 Lausanne (CH). PEDERSEN, Michael, Stan-
ley [DK/CH]; Chemin Davel 24, CH-1009 Pully, Vaud
(CH). ZELLWEGER, Matthieu [CH/CH]; Rue Patru 6,
CH-1205 Geneva (CH). GOUIN, Sebastien [CA/VN]; 8
Chau Long, Ba Dinh District, Ha Noi (VN). ROORDA,
Sicco Dirk [NL/CH]; Ch. de Villardiez 16, CH-1009 Pul-
ly (CH). PHAN, Thi Quynh Chi [VN/VN]; 177 A Luong
The Vinh Street, Thanh Xuan District, Hanoi (VN).

(74) Agent: PATRADE A/S; Fredens Torv 3A, DK-8000
Aarhus C (DK).

(81) Designated States (unless otherwise indicated, for every
kind of national protection available): AE, AG, AL, AM,
AO, AT, AU, AZ, BA, BB, BG, BH, BR, BW, BY, BZ,
CA, CH, CL, CN, CO, CR, CU, CZ, DE, DK, DM, DO,
DZ, EC, EE, EG, ES, FI, GB, GD, GE, GH, GM, GT,
HN, HR, HU, ID, IL, IN, IS, JP, KE, KG, KM, KN, KP,
KR, KZ, LA, LC, LK, LR, LS, LT, LU, LY, MA, MD,
ME, MG, MK, MN, MW, MX, MY, MZ, NA, NG, NI,
NO, NZ, OM, PE, PG, PH, PL, PT, RO, RS, RU, SC, SD,
SE, SG, SK, SL, SM, ST, SV, SY, TJ, TM, TN, TR, TT,
TZ, UA, UG, US, UZ, VC, VN, ZA, ZM, ZW.

(84) Designated States (unless otherwise indicated, for every
kind of regional protection available): ARIPO (BW, GH,
GM, KE, LS, MW, MZ, NA, SD, SL, SZ, TZ, UG, ZM,
ZW), Eurasian (AM, AZ, BY, KG, KZ, MD, RU, TJ,
TM), European (AT, BE, BG, CH, CY, CZ, DE, DK, EE,
ES, FI, FR, GB, GR, HR, HU, IE, IS, IT, LT, LU, LV,
MC, MK, MT, NL, NO, PL, PT, RO, SE, SI, SK, SM,
TR), OAPI (BF, BJ, CF, CG, CI, CM, GA, GN, GQ, GW,
ML, MR, NE, SN, TD, TG).

Published:

— without international search report and to be republished
upon receipt of that report (Rule 48.2(g))

(54) Title: INSECTICIDAL POLYMER MATRIX COMPRISING HDPE AND LDPE

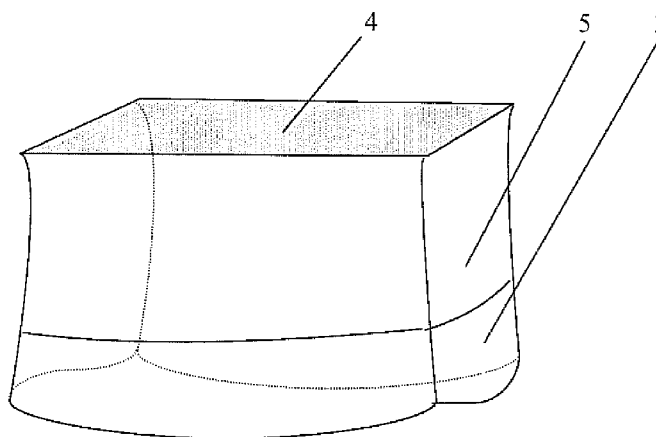

FIG. 5

(57) Abstract: Insecticidal polymer matrix comprising HDPE and LDPE An insecticidal polymer matrix containing HDPE (high density polyethylene), LDPE (low density polyethylene), preferably containing PBO (Piperonyl Butoxide) and DM (Deltamethrin), wherein the ratio of the contents of HDPE to LDPE is between 5 and 20 and most preferably between 8 and 10. The matrix is highly useful for bed nets against mosquitoes.



Insecticidal polymer matrix comprising HDPE and LDPE

Field of the Invention

The present invention relates to an insecticidal polymer matrix comprising HDPE and LDPE.

5 Background of the Invention

In connection with insecticide control, it is well known that insecticides can be integrated in polymer material in order to prevent insects to work their way through the material. However, when it comes to the control of release rates of insecticides in a polymer matrix, this is regarded as a difficult issue, because a release that is too rapid
10 exhausts the matrix quickly with regard to insecticidal effect, and a too slow release does not have the desired efficiency or suitable regeneration properties in case the insecticide falls off or is removed, for instance, by washing.

For crop sheets, as disclosed in US 4,888,174, it is known to mix LDPE with other
15 polymers in order to reduce the migration speed. This is in line with the disclosure of International Patent Application WO 02/34487, stating that "*the selection of the polymers depends on the desired release rate*", where the disclosure proposes a pesticide-retaining layer of LDPE (low density polyethylene) bonded to a layer of HDPE (high density polyethylene), where the HDPE layer prevents a too fast release of the insecti-
20 cide.

International patent application WO 2008/004711 discloses an insecticidal resin containing HDPE and LDPE. Deltamethrin is one of the possibilities of insecticides, however, no relation is stated for the ratio between HDPE and LDPE in this resin with
25 deltamethrin. A ratio of 12.1 is implicitly stated in a single example for an HDPE/LDPE matrix containing 87.23% HDPE and 7.2% LDPE, permethrin, fine silica powder and a number of other ingredients. Although permethrin is also a pythroid, this ratio of 12.1 contains no information about advantageous ratios of HDPE/LDPE for deltamethrin (DM). This is so, because

30 - DM has a much higher molecular weight than permethrin, which influences the diffusion coefficient;

- DM has a higher polarity than permethrin which results in DM having a lower affinity in the non-polar PE; and

- DM has a vapour pressure an order of magnitude lower than permethrin.

Furthermore, the example states the content of fine silica powder, zinc stearate, and
5 other ingredients affecting the migration rate of permethrin. In addition, the effective insecticidal amount needed on the surface of the substrate, is generally different for the two insecticides permethrin and DM. Using this above information about the difference between DM and permethrin, the conclusion is that the ratio should be much
10 different than the stated 12.1 for permethrin. However, it is desirable to have a more precise indication for the ratio between HDPE and LDPE in an insecticidal matrix useful in connection with DM.

For cables, it is known from US 4680328 to extrude insecticidal polymer blends with
LDPE, HDPE and LLDPE (linear low density polyethylene) and a preferred insecti-
15 cide halopyridyl phosphate.

Apart from the difficulty of achieving a suitable migration speed of insecticide in
polymer matrices, the combination of an insecticide, for example DM (Deltamethrin),
and a synergist, for example PBO (piperonyl butoxide), incorporated in a polymer
20 matrix implies additional challenges. Despite the fact that incorporation of a pyrethroid and PBO has been reported in connection with pet collars, for example in International patent application WO 00/40084 or WO 06/127407, the migration speed for long lasting insecticidal nets (LLIN) or fabrics is still an unresolved problem in practice. This is due to the fact that several parameters have to be fitted together to yield a
25 product that is satisfactory. The parameters have to be found such that, firstly, the insecticidal dose on the surface of the material should be sufficiently high for killing insects, secondly, the release should last for more than a year in the case of LLIN, and should allow regeneration of the net's activity in case of washing of the net, and thirdly, the overall content of the insecticide and synergist should be low in order to
30 keep the cost for LLIN at a minimum, as well as to minimize the potential exposure of an end-user to the active ingredients contained in the net. The latter are important factors, because the largest markets for LLIN are regions with low income, and the primary end-users are infants and young children.

International patent application WO 2006/111553 discloses microcapsules with a solution of an insecticide, for example DM, and a synergist, for example PBO, in an aqueous suspension inside a polyurea capsule. The ingredients of the microcapsule are released due to breakage of the microcapsule wall when it dries after spraying. The background for this disclosure is the assumption that release of the insecticide should be several hours delayed as compared to the release of the synergist. In the disclosed Example 5, the amount of synergist PBO relatively to the insecticide DM is a factor of 2 in the premix A. As shown in FIG. 1, this premix is then surrounded by an emulsion containing a premix B containing 81% PBO. When used in connection with FIG. 2 of WO 2006/111553, the blend of Premix A and premix B with 5.9% DM and 23.9% PBO yields a ratio of 4.1 between PBO and DM which is further surrounded by premix B containing PBO. Although stating precise figures for containment of PBO and DM in an aqueous suspension inside a microcapsule for delayed release of DM relative to PBO, this disclosure does not give any hint as to the content of PBO relative to DM in a polymer matrix, for example a polyethylene matrix, where the insect shall be exposed to PBO and DM simultaneously by DM and PBO migrated to the surface of the matrix.

Object of the Invention

It is the object of the invention to provide an insecticidal polymer matrix containing HDPE and LDPE with optimised migration capabilities for DM, and, especially, a polymer matrix for producing insecticidal fibres for LLIN and other insecticidal fabrics.

Description of the Invention

This purpose is achieved with an insecticidal polymer matrix containing HDPE (high density polyethylene) and LDPE (low density polyethylene). The matrix also contains an insecticide as part of the material of the matrix, that is, the insecticide is incorporated into the material. The insecticide is arranged for migration from inside the material to the surface of the matrix. Further, the ratio of the contents of HDPE and LDPE is between 3 and 30, preferably between 5 and 20, rather higher than 5 and lower than 12, such as between 5 and 11 or 5 and 10, or even between 8 and 10. The insecticide

is, preferably, an insecticide different from permethrin, and most preferably, the insecticide is deltamethrin (DM).

5 Having regard to the interval of between 5 and 20 when containing DM, this result is surprising relative to the disclosure of a ratio of 12.1 for permethrin in International patent application WO 2008/004711, because one should expect the optimal ratio for DM be substantially different from 12.1, for example a ratio equal to a value around 2 or less due to the entirely different nature of DM, which is in solid form with entirely different parameters than the liquid permethrin.

10

The argument becomes more illustrative when using percentages. A ratio of 5 in a HDPE/LDPE matrix without other ingredients corresponds to 83% HDPE and 17% HDPE if no other ingredients are included in the matrix, and a ratio of 20 corresponds to 95% HDPE and 5% LDPE. Thus, the apparent broad interval of 5 to 20 corresponds to the relatively narrow interval of 83% to 95%. Having regard to the entire different nature of permethrin, one would expect the advantageous content of HDPE in the case of deltamethrin be much smaller than the than the 87.23 % as disclosed for permethrin in WO 2008/004711. However, surprisingly, this is not the case.

15

Preferably, the matrix contains PBO (Piperonyl Butoxide) and DM (Deltamethrin) as part of the material of the matrix.

25 As experiments have shown, the amount of LDPE in a polymer matrix with HDPE should not be too high, in order to assure an optimal migration rate of the PBO and the DM, whilst concomitantly achieving optimal mechanical properties of the polymer matrix. In this case, both substances migrate to the surface of the material, preferably a mosquito net, and expose the insect to PBO and DM instantaneously. This is a different strategy than for the micro capsules in the above mentioned International patent application WO 2006/111553.

30

Though, the two polymers HDPE and LDPE may be mixed with other polymers, experiments did show good results with only these two polymers constituting the polymer matrix. Also, preferably, the matrix is free from fine silica powder, or zinc

stearate, or both of them in contrast to the matrix as disclosed in the above mentioned WO 2008/004711.

Surprisingly, the insecticidal efficiency in a polymer matrix is dependent on the content of PBO relative to the content of DM. Thus, it was found that the ratio in terms of weight between the content of PBO and the content of DM should be higher than 3 or 4, rather higher than 5, for example between 5 and 10. It is understood that PBO and DM are part of the matrix material for migration from inside the material to the surface of the matrix.

10

The content of deltamethrin, preferably, is less than 1.5%, more preferably less than 1%, of the weight of the polymer matrix.

Experimentally, the ratios between PBO and DM were found advantageous in connection with a polymer matrix consisting of HDPE and LDPE, especially for a polymer matrix, where the ratio between HDPE and LDPE is between 5 and 11 or 5 and 10, such as 8 and 10. However, it seems that this is valid as well for polymer matrices, where other polymers are added to HDPE and LDPE.

The above mentioned minimum ratios between the PBO and the pyrethroid are much higher than the ratio of 2 as disclosed in WO 00/40084.

Generally, it seems that an advantage over the prior art is achieved, if an insecticidal polymer matrix is selected with a PBO content in terms of weight higher than 3 times, for example higher than 4 times or 5 times, the content of the DM in the polymer matrix, rather between 5 and 10 times or even more preferably between 8 and 10. The type of polymer is preferably a thermoplastic polymer, especially a polyolefin. Thus, these ratios are advantageous on a general basis not only for polyethylene, as described above, but also for other polymers, for example polypropylene.

30

The surface content of PBO and DM on the surface of a polymer matrix depends on the migration rate of PBO and DM in the polymer as well as on the thickness of the polymer substrate (i.e. the distance to the surface). The migration rate is influenced

by, amongst other factors, the proportion of amorphous phase in the polymer (i.e. the percentage of crystallinity), the diffusion coefficient, which, in turn, is affected by the temperature and the degree of affinity between the additives and the polymer. Therefore, the surface content of DM and PBO at any moment in time is determined by a combination of various thermodynamic effects but also by the shape of the polymeric substrate being in the form of a yarn, a foil, or a bulk product. The above ratios were verified as being useful for an insecticidal matrix in the form of a fully drawn monofilament yarn with a diameter of between 0.05 mm and 0.3 mm, preferably between 0.1 mm and 0.15 mm. Especially, the HDPE and LDPE ratio of between 5 and 10, or rather between 8 and 10, was suitable for such filaments. However, the above figures are also useful for multifilaments having a linear density in the same range.

A useful amount of DM in a matrix according to the invention is between 1g and 6g per kg polymer, for example, between 1g and 5g or between 2g and 6g or between 3g and 5g per kg polymer..

A preferred combination of parameters is the following,

- the insecticidal matrix is in the form of a monofilament, preferably fully drawn, with a diameter of between 0.05 mm and 0.30 mm, or an insecticidal matrix in the form of monofilaments of the type between 50 and 100 Denier,
- the weight content of DM is between 2g and 6 g, for example between 3g and 5g, per kg polymer,
- the weight content of PBO is more than 3, or rather more than 5 times, times the weight content of the DM.

Another preferred combination is - the insecticidal matrix is in the form of a monofilament, preferably fully drawn, with a diameter of between 0.05 mm and 0.30 mm, or an insecticidal matrix in the form of monofilaments of the type between 50 and 100 Denier,

- the ratio between the content of HDPE relative to the content of LDPE in the matrix is between 8 and 10, for example the content of LDPE is between 9% and 11%;

- the weight content of DM is between 2g and 6 g, for example between 3g and 5g, per kg polymer,
- the weight content of PBO is more than 3 times, or rather more than 5 times, the weight content of the DM.

5

A preferred combination of parameters is the following,

- the insecticidal matrix is in the form of a monofilament, preferably fully drawn, with a diameter of between 0.10 mm and 0.15 mm, or an insecticidal matrix in the form of monofilaments of the type between 50 and 100 Denier,
- the ratio between the content of HDPE relative to the content of LDPE in the matrix is between 8 and 10, for example the content of LDPE is between 9% and 11%;
- the weight content of DM is between 3g and 5g per kg polymer,
- the weight content of PBO is between 5 and 7 times the weight content of the DM.

10

15

20

25

At this point, it should be emphasized that the content of DM is in the sub-percent range and the content of PBO is in the range of a few % only, whereas in International application WO 00/40084 the content of Pyrethroid is in the range of up to 10% and the content of PBO is in the range up to 20%. By including vast amounts of insecticide and synergist in a matrix, high insecticidal efficiency and also relatively long lasting effect can, indeed, be achieved. However, for LLIN, this must withstand the additional constraint of regeneration of insecticidal activity after washing in an interval that is relevant for the end product, typically less than seven days. Furthermore, the risk to end users and the production costs should be low, which requires an as low content as possible, though still enough for sufficient long lasting effect and multiple regenerations following repeated washings at regular intervals.

30

A highly preferred use of the filament matrix according to the invention is a monofilament yarn as part of a woven net, especially bed nets against mosquitoes. For bed nets, the entire net may be made of such insecticidal matrices according to the invention, but in some cases, it is preferred that only the roof is made thereof. The side

walls could then be made of polymer containing DM but not PBO, for example a polyethylene matrix with DM. Alternatively, the side walls are made of another material, for example polyethylene terephthalate (PET), also called polyester (PES).

5 One of the ways to slow down chemical or photochemical degradation of PBO and DM on the surface of the matrix uses an antioxidant distributed, preferably homogeneously distributed, in the polymeric substrate. Such antioxidants is used to decompose as fast as possible any reactive species, for example radicals and peroxides, formed with time on order to prevent reaction with and changing of the chemical nature of
10 DM or PBO in such a way that their bioactivities is detrimentally affected.

In addition, special migration promoters or inhibitors may be used to adjust the migration speed. For example, some promoters or inhibitors may work more or less on DM than on PBO, by which the migration speed of these two components can be adjusted
15 relatively.

The matrix according to the invention is primarily intended for extrusion, however, it may as well be used in moulding processes. Thus, the DM, and optionally the PBO, is incorporated into the molten polymer.

20 Other ingredients for a matrix according to the invention are found among UV protectors, plasticizers, colorants, preservatives, detergents, fillers, impact modifiers, anti-fogging agents, blowing agents, clarifiers, nucleating agents, coupling agents, conductivity-enhancing agents to prevent static electricity, stabilizers, for example, carbon
25 and oxygen radical scavengers, flame retardants, mould release agents, optical brighteners, spreading agents, antiblocking agents, foam-forming agents, anti-soiling agents, thickeners, further biocides, wetting agents, plasticizers adhesive or anti-adhesive agents, fragrance, pigments and dyestuffs and other liquids including water or organic solvents.

30 Apart from the incorporation of DM and PBO in the matrix, the matrix may be coated with other insecticidal agents, for example Carbamates or Organophosphates. This can be used as a measure against insecticidal resistance. However, in this case, it should

be assured that the coating is configured for migration of the DM and PBO through the coating.

5 Apart from using the matrix according to the invention for bednets and fabrics, the matrix may also be used for tarpaulins, foils, flat yarns and bulk material. Such different materials may be combined by different kind of bonding techniques or sewing techniques. Also, materials with an insecticidal polymer matrix according to the invention may be combined with materials containing other insecticides. For example, a net or fabric with a polymer matrix according to the invention may be combined with
10 a different net, fabric, foil, flat yarn or tarpaulin containing a different insecticide in order to combat insecticidal resistance.

The extrusion should be relatively mild, with a temperature lower than 240°C, and with minimal residence time, water quenching of the yarns, and in-line drawing of the
15 yarn to a draw ratio of 5 to 11, 5 to 10, or 8 to 10, thus, achieving the crystallinity of the yarn/matrix associated with the state of “fully drawn yarn”, and the desired migration rate and as well as other suitable physical properties.

For mosquito nets, for example with fibres of 75 or 100 Denier, a non limiting appropriate content of DM is larger than 1g/kg, preferably larger than or at least 2 g/kg.
20 Optionally, the content of DM is lower than 5 g/kg, preferably at most or lower than 4 g/kg. An interval of between 2 and 4 g/kg has been experienced as a good interval for such fibres in mosquito nets.

25 Optionally, the end points of all stated intervals may be part of the intervals.

Description of the Drawing

The invention will be explained in more detail with reference to the drawing, where
FIG. 1 illustrates the influence of time lag on the efficacy of PBO exposure and DM;
30 FIG. 2 illustrates the effect of the content ratio between PBO and DM;
FIG. 3 shows a first embodiment of a bed net according to the invention with a roof that contains PBO and DM;

FIG. 4 shows a second embodiment of a bed net according to the invention, the bed net having a skirt;

FIG. 5 illustrates a rectangular net.

Detailed Description of the Invention

5 The path leading to the invention did comprise a number of intermediate steps, in as much as the solution, despite its simplicity is not straightforward.

In the teaching in the field of insecticidal nets, it has hitherto been assumed that PBO has to be transferred to the mosquito well in advance to the exposure to DM, because
10 the PBO was believed to need a certain time in the mosquito before it temporarily breaks down the resistance mechanism. This is reflected in the above mentioned International patent application WO 2006/11155. As the degradation of PBO by sunlight/visible light creates radicals leading to a degradation of the DM, it has hitherto been believed that a provision of PBO and DM at the surface of the net at the
15 same time and at the same position is a hinder for an efficient insecticidal net, because the time lapse between the necessary PBO exposure to the mosquito before the DM exposure leads to a degradation of the DM in the mean time. This implied a conclusion that a polymer having incorporated DM as well as PBO for migration to the surface of the material is not a proper material for insecticidal nets. It should be mentioned here that no LLIN with incorporated PBO and DM have found way to the market yet, despite a great demand for a feasible solution. Instead, encapsulation of synergist and insecticide together with an antioxidant into UV protected microcapsules has been proposed in US patent No. 4,056,610 as one of the measures to overcome this problem.

25

One of the corner stones of the invention is the fact that experiments revealed that the bioefficacy of PBO and DM treatment is highest when mosquitoes were exposed to PBO and DM simultaneously. As described above, this is against the teaching in the field of insecticidal nets. A proof for this is illustrated in FIG. 1, showing that for different dosages, there was a remarkable increase in efficacy when DM and PBO were
30 provided to the mosquito at the same time.

Having recognised this, there was a new motivation for providing a polymer matrix containing PBO and DM, where both can be found on the surface of the matrix and migrate at a similar rate so as to replenish the surface after depletion (by washing, for instance) in order to expose insects to DM and PBO at the same time. As long as there is a steady release of these two substances, the efficacy against mosquitoes is optimal. Of course, this is compounded by the added constraint for LLINs that the said polymer matrix, once knitted into a netting material, should have suitable migration properties so that PBO and DM be regenerated at the surface of the yarn/fabric following washing.

The question then arises, which material should be chosen for the matrix. Studies revealed that polyester has a very slow migration rate, which was not sufficient to release enough DM and PBO through migration of polyester yarn of 100 Denier, even when used a multifilament with 35 filaments. HDPE had a release rate which was higher than for polyester, but not high enough for sufficient insecticidal efficacy or regeneration at a rate suitable for mosquito netting materials, despite good mechanical properties making it suitable for knitting into netting material. On the other hand, LDPE has a migration rate, which is far too high for a LLIN, and yarns made of pure LDPE have low mechanical properties that make them unsuitable for knitting into netting material. Thus, according to the invention, a mixture of LDPE and HDPE was envisaged, and it was found empirically, that for sufficient but also long lasting release of DM and PBO, a mixture of HDPE and LDPE was optimum, where the weight ratio between HDPE and LDPE was between 30 and 3 and rather between 20 and 5. The ratio depends on the thickness of the matrix. For monofilament yarns with a thickness of 0.06 mm, the HDPE/LDPE weight ratio was best between 15 and 25 and for yarns with a thickness of 0.25 mm, the ratio was best between 4 and 7. For yarn thickness in between these two numbers, the ratio may be interpolated. These parameters seem to give the said monofilament yarns adequate crystallinity at a given draw ratio and therefore an appropriate migration rate at the typical temperature these products are used.

In the experiments, no other polymers were introduced into the matrix. The above ratios corresponded in these experiments to a LDPE weight content of between 3.5%

and 35% in the HDPE/LDPE matrix, whereas, however, the preferred content of LDPE in terms of weight was between 5% and 17%, better between 8% and 12%.

5 A successful monofilament yarn with a diameter of 0.10 mm to 0.15 mm, for example around 0.12 mm, the content of HDPE and LDPE in terms of weight was at a ratio between 8 and 10, rather around 9, corresponding to an LDPE content of around 10%, when no other polymers were introduced.

10 However, as it turned out, not only the ratio between the content of HDPE and LDPE could be used to optimise the yarn with respect to long lasting high efficiency. Also the content of the PBO content relative to the DM content proves to be crucial.

15 In this connection, FIG. 2 shows the PBO/DM ratio as abscissa and a percentage Functional Mortality of resistant *Culex quinquefasciatus* as ordinate for two different DM dosages, namely dosage DM1=1.32mg/m² and dosage DM2=1.76mg/m² in a WHO cone test with a mixture of DM and PBO. From FIG. 2, it is apparent that the ratio between PBO and DM in terms of weight should be above 4, or rather above 5, in order to yield a high efficacy against mosquitoes. However, a ratio far above 5 does not improve the effect.

20 Examples of successful yarns had diameters of between 0.10 mm and 0.15 mm, for example around 0.12 mm, containing 4g DM per kg polymer and 25g PBO per kg polymer. For example, the content of HDPE and LDPE in terms of weight at a ratio is between 8 and 10, for example around 9. Due to necessary initial migration before a
25 sufficient content is reached at the surface of the matrix, the yarn, advantageously, can be stored for a certain time to reach sufficient efficacy, for example a week to reach 80% efficacy.

30 The content of DM and PBO may be varied. For example, in the yarn with a thickness of between 0.10 mm and 0.15 mm, and a HDPE and LDPE weight content ratio of between 8 and 10, the content of DM may be selected between 2g and 6g DM per kg polymer and correspondingly 4 to 10 times as much PBO, preferably between 5 and 7 times as much PBO, for example 6 times as much PBO.

The monofilament polyethylene yarns may successfully be used for bed nets, where the entire net is provided with such material. However, in case that the side walls of the nets are preferred to be produced in polyester multifilament due to the relatively higher softness and cotton like feeling, the extruded HDPE/LDPE monofilament yarn may be used for the top part of the net. The efficacy will in most cases still be high, because mosquitoes typically attack their potential victims from above and tend to land on the roof of bed nets, especially rectangular bed nets.

As a further addition, migration promoters may be included in the molten matrix prior to extrusion of the insecticidal polyethylene blend.

FIG. 3 illustrates a conical canopy net 1 above a bed 6 to protect humans on the bed 6 from being attacked by insects, primarily mosquitoes. The roof 4 of the net 1 is provided as a material according to the invention with PBO and DM incorporated in a polymer matrix, and the side walls 5 of the canopy 1 comprise an insecticide but no PBO. A stabilising ring 9 is inserted between the roof 4 and the side walls 5.

FIG. 4 illustrates a conical canopy insecticidal barrier according to another embodiment of the invention, wherein the roof 4 and the side wall 5 are provided as a material according to the invention with PBO and DM incorporated in a polymer matrix. The side wall 5 extends to the lower edge 30 of the barrier and has an upper part 2 and a lower part 3. The canopy insecticidal barrier is intended to cover a space for human beings or animals, for example a bed 6 as illustrated in FIG. 4. In order to enter the space underneath the canopy, the lower part 3 of the barrier 1 is exposed to surface touch and, therefore, exposed to abrasion of insecticide from the surface of the material. In order to increase the strength of the net, the lower part 3 is has a material with higher abrasion resistance and mechanical strength, for example a stronger net, a fabric or a tarpaulin or a combination of these. Also, the lower part 3 may be provided with higher insecticidal content in order to take into account the higher abrasion of the insecticide from the surface of the material.

The thickness of the filaments for bed nets may vary in dependency of the actual requirements for the net. Typically, yarns with a weight of between 50 Denier and 100 Denier are used.

5 FIG. 5 shows a rectangular shape for a net, which may substitute the shapes of the nets in FIG. 4 and FIG. 3. However, the net in FIG. 5 has a roof 4 with a polymer matrix according to the invention, whereas the side walls 5 are multifilament polyester in order for the side walls to have soft, cotton like feeling. In order to provide additional strength to the lower part 3 of the side walls 5, the net has a tighter knit in this part 3.

10 The walls of the net are provided without PBO but with DM impregnation complying with WHO specification 333/TC and being wash resistant and largely in line with the impregnation method in the disclosure of International patent application WO 01/37662, which also is used for the well known bed net under the trademark PermaNet®. The side wall 5 is provided with between 2.5 g and 3.5 g DM per kg of the matrix, which mainly is the polymer. As the yarn density is different in the lower part

15 3 of the side walls 5, the amount per square meter is higher. For example, if the value is chosen to 2.8 g/kg in a 75 Denier yarn, for example with about 40g/m^2 for the lower part of the side walls and 30g/m^2 for the remaining part of the side walls, the DM level is 115 mg/m^2 of the lower part 3 of the side wall 5 and 85 mg/m^2 in the remaining part of the side wall 5. The preferred net had a minimum of 24 holes per cm^2 . The preferred amount of DM in the roof net with 100 Denier was chosen to be between 3 and 5 g/kg cooperating with a PBO content between 5 to 7 times, rather around 6

20 times, as large as the DM content.

CLAIMS

1. An insecticidal polymer matrix made of a material containing high density polyethylene (HDPE) and low density polyethylene (LDPE), and deltamethrin (DM),
5 wherein the DM is part of the material and arranged for migration from inside the material to the surface of the matrix, wherein the ratio of the content of HDPE to LDPE is between 5 and 20 in terms of weight.
2. An insecticidal polymer matrix according to claim 1, wherein the ratio of the
10 contents of HDPE to LDPE is between 5 and 11.
3. An insecticidal polymer matrix according to claim 1, wherein the ratio of the contents of HDPE to LDPE is between 8 and 10.
- 15 4. An insecticidal matrix according to any preceding claim, wherein the matrix also contains Piperonyl Butoxide (PBO) as part of the material.
5. An insecticidal matrix according to claim 4, wherein the ratio between the content of PBO and the content of DM in terms of weight is higher than 3.
20
6. An insecticidal matrix according to claim 5, wherein the ratio between the content of PBO and the content of DM in terms of weight is higher than 5.
7. An insecticidal matrix according to claim 6, wherein the ratio between the content of PBO and the content of DM is between 5 and 10.
25
8. An insecticidal matrix according to any preceding claim, wherein the insecticidal matrix is in the form of a monofilament with a diameter of between 0.05 mm and 0.35 mm.
30
9. An insecticidal matrix according to claim 8, wherein the diameter is between 0.1 mm and 0.15 mm.

10. An insecticidal matrix according to any preceding claim, wherein the content of DM is between 2g and 6g per kg polymer.
11. An insecticidal matrix according to claim 1, wherein
- 5 - the insecticidal matrix is in the form of a monofilament with a diameter of between 0.05 mm and 0.35 mm,
- the insecticide is DM with a weight content of DM is between 2g and 6g per kg polymer,
- the matrix contains PBO with a weight content higher than 3 times the weight content of the DM.
- 10
12. An insecticidal matrix according to claim 1, wherein
- the insecticidal matrix is in the form of a monofilament with a diameter of between 0.10 mm and 0.15 mm,
- 15 - the ratio between the content of HDPE relative to the content of LDPE in the matrix in terms of weight is between 8 and 10,
- the insecticide is DM with a weight content of between 3g and 5g per kg polymer,
- the matrix contains DM with a weight content of between 5 and 7 times the weight content of the DM.
- 20
13. An insecticidal matrix according to any preceding claim 11 or 12, where the content of LDPE is between 9% and 11%.
14. An insecticidal matrix according to any preceding claim in the form of a yarn as
- 25 part of a bed net.
15. An insecticidal matrix according to claim 14 in the form of a monofilament yarn comprising PBO and DM as part of the roof of a bed net and in form of monofilament yarn containing DM but no PBO as side walls for the bed net.
- 30 16. An insecticidal matrix according to claim 14 in the form of a monofilament yarn as part of the roof of a bed net, the bed net further having side walls made of a different material.

17. An insecticidal matrix according to claim 16, wherein the bed net has side walls made of multifilament polyester with an insecticidal coating.

FIG. 1

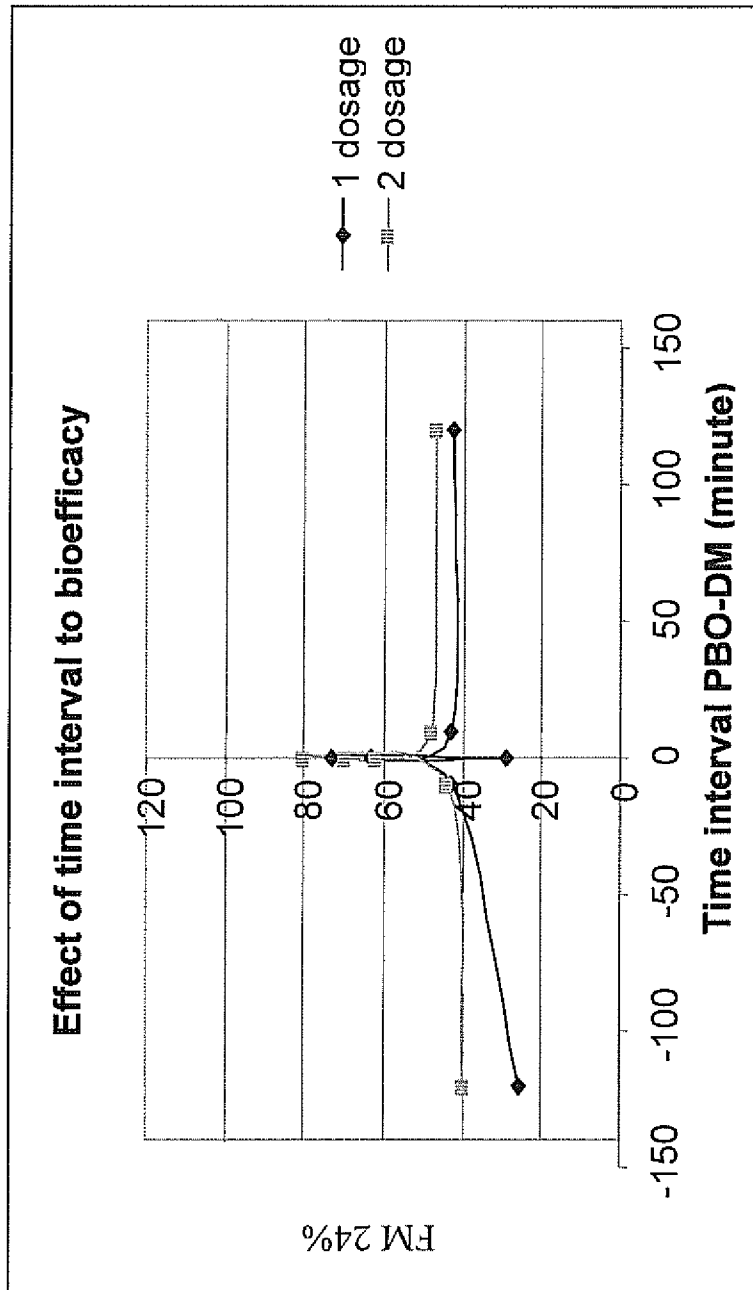
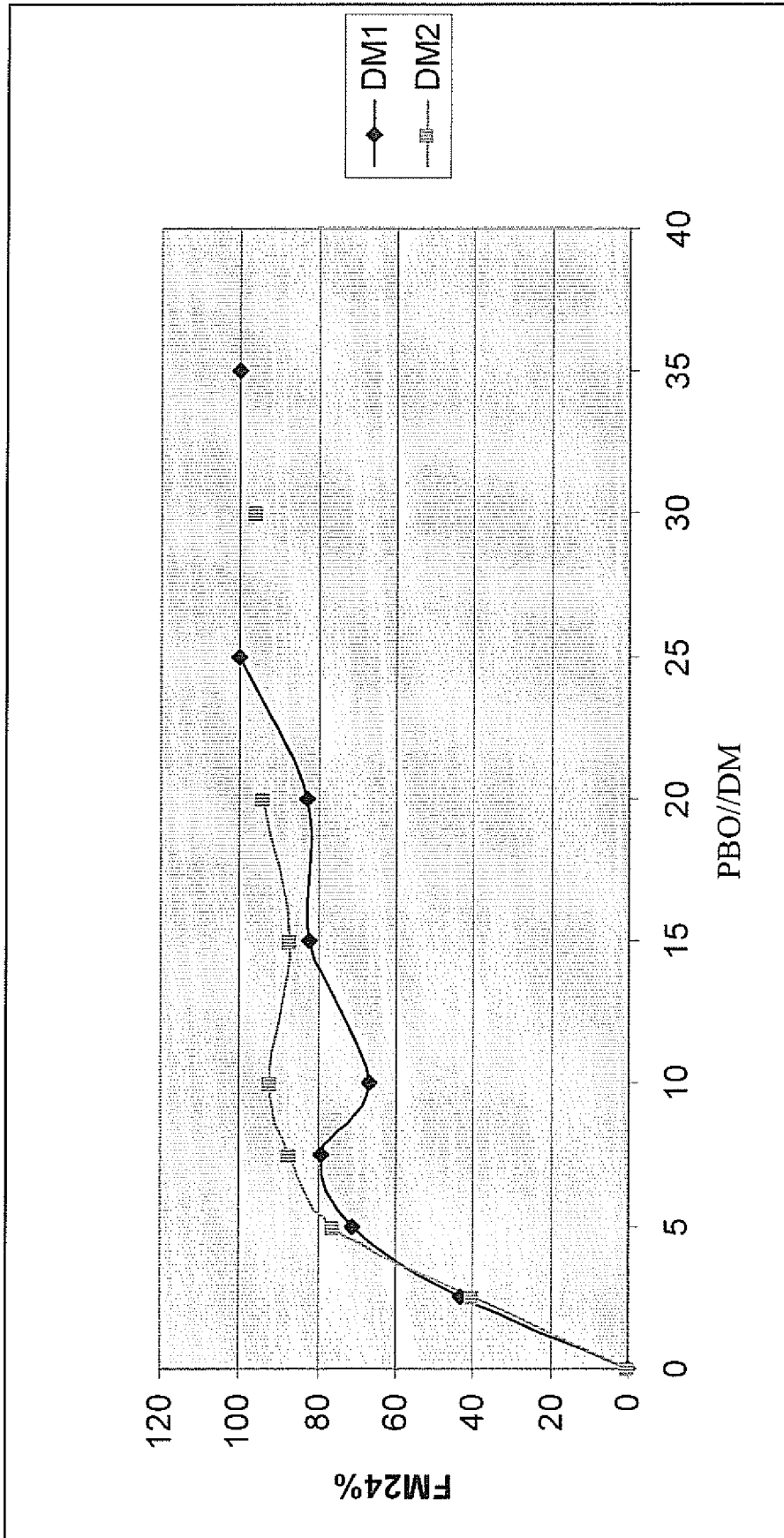

FIG. 2



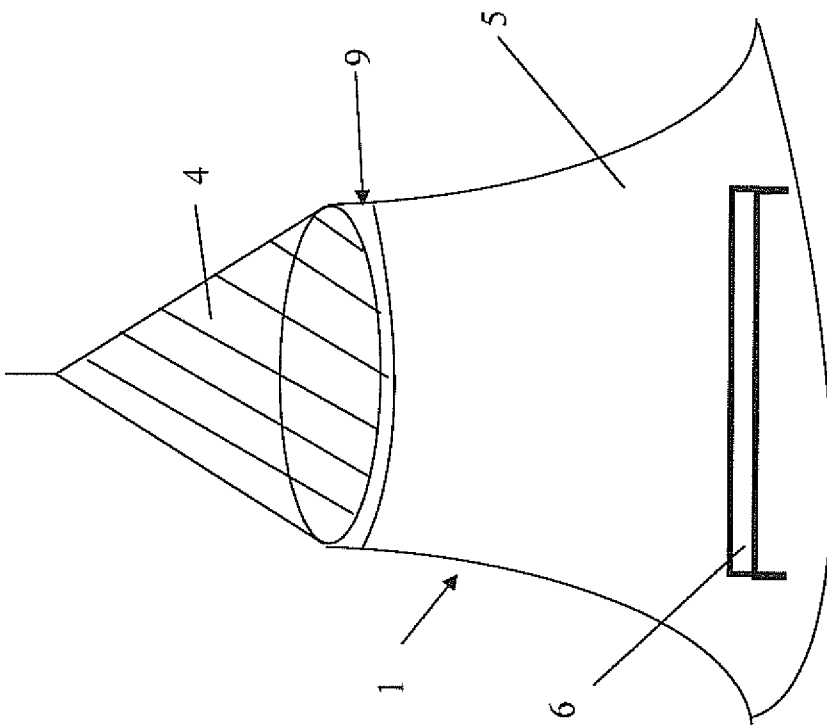

FIG. 3

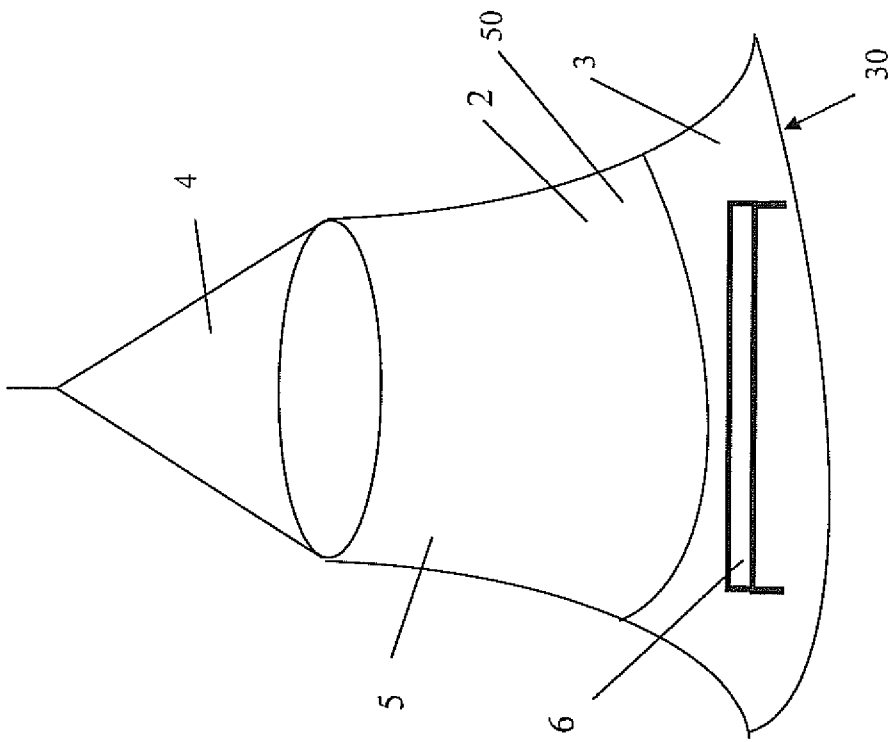

FIG. 4

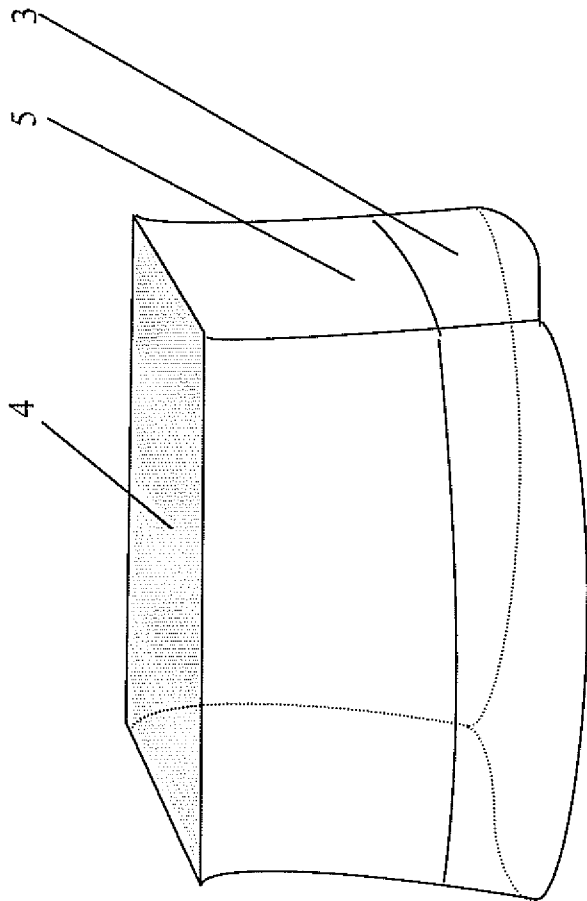

FIG. 5