



(12) **EUROPEAN PATENT APPLICATION**

(43) Date of publication:  
**02.04.2008 Bulletin 2008/14**

(51) Int Cl.:  
**E06B 3/96 (2006.01) E06B 3/984 (2006.01)**

(21) Application number: **06425639.9**

(22) Date of filing: **15.09.2006**

(84) Designated Contracting States:  
**AT BE BG CH CY CZ DE DK EE ES FI FR GB GR HU IE IS IT LI LT LU LV MC NL PL PT RO SE SI SK TR**  
 Designated Extension States:  
**AL BA HR MK YU**

(72) Inventor: **Tenzon, Franco**  
**37046 Minerbe (Verona) (IT)**

(74) Representative: **Gallo, Luca et al**  
**Gallo & Partners S.r.l.**  
**Via Trieste, 49**  
**35121 Padova (IT)**

(71) Applicant: **Uniform S.p.A.**  
**37046 Minerbe VR (IT)**

(54) **Corner joint for door and window frames**

(57) Corner joint for sections (2,3) of door and window frames, which can be joined together by means of fixing means comprising a pin (8) able to engage in a seat (7) defined by a pair of first openings (5,6) formed

in the faces (2',3') of the sections and on either side of the joining plane. Also envisaged is a connection element which is arranged between the sections along the joining plane and provided with second openings located opposite the first openings.

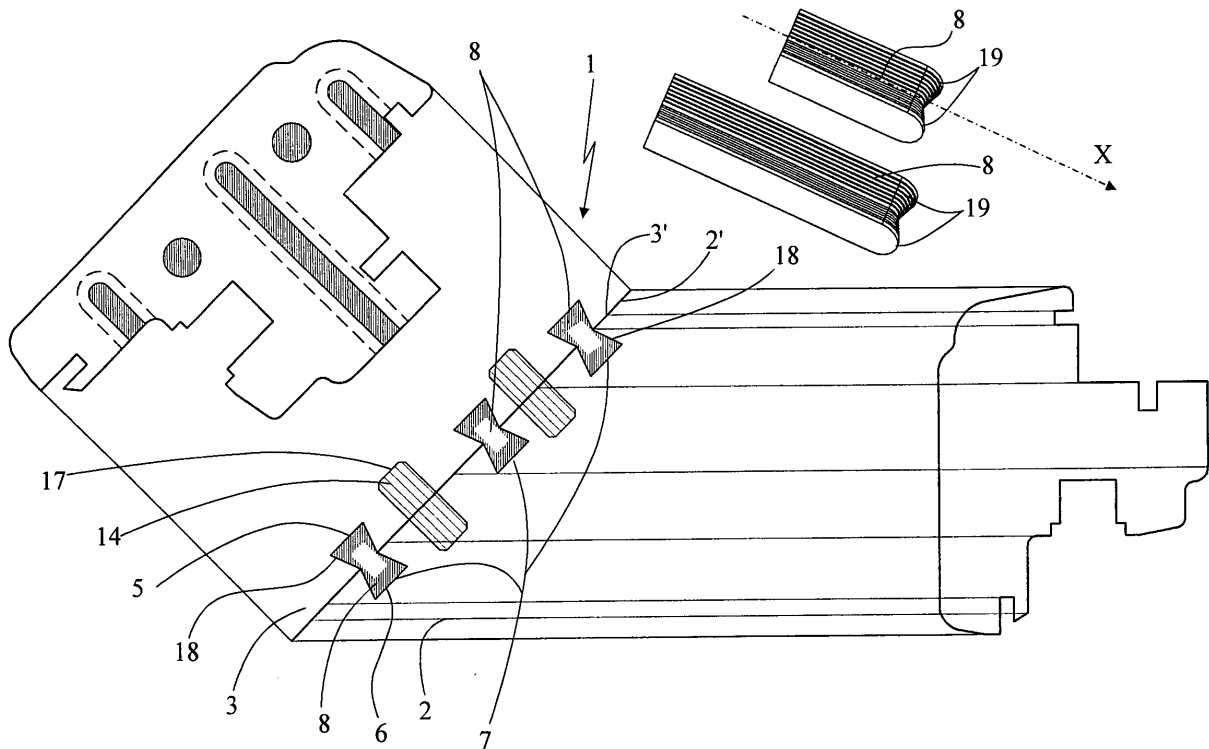

**Fig. 4**

## Description

### Technical field

**[0001]** The present invention relates to a corner joint for sections of door and window frames.

**[0002]** The joint in question is intended to be used mainly in the sector relating to the production of wooden door and window frames or accessories for door and window frames, in particular for rigidly fixing together two sections of a frame along the joining plane.

### Background art

**[0003]** As is known, the frame of a door or window, which may or may not be associated with cladding mouldings made of metal or PVC, usually consists of several wooden sections the ends of which are fixed in pairs at the corners of the frame, by means of a corner joint provided with suitable connection means.

**[0004]** The sections thus assembled in the form of a surrounding frame may form either a casement, intended to be inset in a brickwork wall, or a leaf of a door or a window and, in this latter case, usually delimit a glazed surface.

**[0005]** The connection means mentioned above may be, in accordance with the known art, of various types and for example envisage providing on the joining face of a first section several shaped projections alternating with recesses which are able to mate with corresponding recesses and projections provided on the joining face of the other section.

**[0006]** The sections may be connected together at 90°, i.e. with a first section in contact laterally on the other one, or at 45°, i.e. with an inclined common face.

**[0007]** It is known, for example from the patents EP 370,334, FR 1,175,665, BE 903,745, US 1,793,185, US 4,183,187, UK 2,076,924, AT 29 27 942, to use connection means consisting of wedges or pins provided with widened portions, generally in the form of a dovetail, which can be inserted into seats formed on either side of the joining plane and provided with an undercut inside which the widened portions of the pins grip so as to retain rigidly together the two sections of the frame.

**[0008]** In greater detail, according to the teaching of EP 370 334, the pins are inserted transversely with respect the plane defined by the surrounding window or door frame, while according to the teaching of FR 1,175,665, the pins are inserted parallel to the plane of the surrounding window or door frame.

**[0009]** The joining face may be provided with further coupling or centring elements usually consisting of cylindrical pins and corresponding seats formed in the opposite faces of the two frame parts to be joined together.

**[0010]** The corner joints used hitherto, which use the connection means mentioned above, have in practice proved to have certain drawbacks.

**[0011]** One drawback consists in the poor seal provid-

ed by the connection means against water infiltration which, as is known, in the long term results in damage to the door or window.

**[0012]** Another drawback, which is common to all door and window frames, consists in the presence of the joining line between the sections which impairs the aesthetic appearance of the door or window.

### Disclosure of the invention

**[0013]** In this situation, therefore, the object of the present invention is to eliminate the drawbacks of the prior art mentioned above, by providing a corner joint for sections of door and window frames, which ensures an optimum seal against atmospheric agents.

**[0014]** Another object of the present invention is to provide a corner joint which is able to fix rigidly together the sections of a door or window frame.

**[0015]** Another object of the present invention is to provide a corner joint which is operationally entirely effective and reliable.

**[0016]** A further object of the present invention is to provide a corner joint which is simple and inexpensive to manufacture.

**[0017]** A further object of the present invention is to provide a corner joint which is not aesthetically impaired by the presence of the line joining together the two faces of the sections of the door and window frames.

### Brief description of the drawings

**[0018]** The technical features of the invention, in accordance with the abovementioned objects, may be clearly understood from the contents of the claims indicated below and the advantages thereof will emerge more clearly from the detailed description which follows, provided with reference to the accompanying drawings, which show a purely exemplary and non-limiting embodiment in which:

- Figure 1 shows a plan view of a first side of the two sections joined together by means of the corner joint according to the present invention;
- Figure 2 shows a plan view of a second side of the two sections joined together by means of the corner joint according to the present invention;
- Figure 3 shows a perspective view of the two sections joined together by means of the corner joint according to the present invention;
- Figure 4 shows an axonometric view of a first embodiment of a corner joint according to the invention;
- Figures 5a, 5b and 5c show, respectively, a perspective view, a front view and a side view of a detail of the joint according to Figure 4 consisting of first example of a corner connection;
- Figure 6 shows an axonometric view of a second embodiment of a corner joint according to the invention;

- Figures 7a, 7b show, respectively, a front view and a side view of a detail of the joint according to Figure 6 consisting of a second example of a corner connection;
- Figure 8 shows an axonometric view of a third embodiment of a corner joint according to the invention;
- Figures 9a, 9b show, respectively, a front view and side view of a detail of the joint according to Figure 8 consisting of a third example of a corner connection;
- Figure 10 shows an axonometric view of a fourth embodiment of a corner joint according to the invention;
- Figures 11a, 11b show, respectively, a front view and a side view of a detail of the joint according to Figure 10 consisting of a fourth example of a corner connection;
- Figure 12 shows an axonometric view of a fifth embodiment of the corner joint according to the invention;
- Figures 13a, 13b show, respectively, a front view and a side view of a detail of the joint according to Figure 12, consisting of a fifth example of a corner connection.

#### Detailed description

**[0019]** With reference to the attached drawings, 1 denotes overall the corner joint for sections of door and window frames according to the invention. This joint is intended for the assembly of wooden sections of any type and any shape in order to form wooden door and window frames suitable in particular for cladding with aluminium or PVC mouldings.

**[0020]** The corner joint 1 comprises in a manner conventional per se a first and a second section, indicated by 2 and 3, which are usually joined together in accordance with the known art by means of fixing means 4 along the respective joining faces 2', 3' of the sections.

**[0021]** The frame which is thus obtained usually has the form of a quadrangular surrounding frame formed by two uprights and two crosspieces which define a plane of lie. This plane is that in which the door or window frame is arranged and comprises an inner side and an outer side.

**[0022]** The fixing means 4 comprise a pair of first openings 5, 6 which are formed in opposite positions on the two faces 2', 3' of the two sections 2, 3 so as to form a seat 7 which extends on either side of the joining plane of the sections and which is able to receive a pin 8 which is shaped so as to match the seat 7 and positioned so as to connect together the said sections 2, 3.

**[0023]** In accordance with the idea forming the basis of the present invention, the joint 1 also comprises a connection element 9 which is arranged between the two sections 2, 3 along the joining plane and has second openings 10 positioned opposite and as a continuation of the first openings 5, 6.

**[0024]** The number of pairs of first openings 5, 6 (and corresponding second openings 10) and the type of fixing means 4 associated with the said first openings 5, 6 for fastening together the two sections 2, 3 may vary depending on the constructional requirements of the frame.

**[0025]** Some preferred embodiments of fixing means 4 will be described below.

**[0026]** The connection element 9 mentioned above substantially consists of a plate which is preferably made of plastic material and which is shaped in the manner of the profile of the joining faces 2', 3', except for the area occupied by the second openings 10.

**[0027]** In accordance with a preferred embodiment of the present invention, the connection element 9 has a first portion 11, which is preferably made of rigid plastic material, such as for example a high-strength ABS synthetic resin, having a perimetral edge 12 able to remain visible along an outer peripheral section thereof, once the frame is completely prepared and assembled.

**[0028]** The example according to Figures 1-3 relates to the frame of a leaf having a first side F1 (Figure 2) intended to receive a cladding with aluminium sections, able to face the external environment, and a second side F2 (Figure 1) intended to face the inside of the building.

**[0029]** The edge 12 of the connection element will therefore in this case be advantageously visible in the side F2 of the frame.

**[0030]** Preferably, the connection element has a second portion 13 which forms one piece with the first portion and is for example obtained by means of co-moulding and which is resiliently yielding under the compressive force exerted by the fixing means 4. In this way, the resilient reaction of this second portion allows the sealing effect between the two sections 2, 3 between which the element 9 is arranged to be increased.

**[0031]** Advantageously, the first portion extends over the entire area of the connection element forming the support core on which the second portion is co-moulded.

**[0032]** In Figures 4, 6, 8, 10 and 12 five examples of fixing means 4 are shown.

**[0033]** In accordance with the first example of Figures 4, 5a and 5b, the connection element 9 has, fixed thereon, two pairs of cylindrical pins 14 which project from its faces 15, 16 in opposite directions so as to be inserted with grip inside corresponding blind holes 17 formed in the faces of the two sections 2, 3.

**[0034]** These pins 15, in addition to increasing the mechanical grip between the two sections 2 and 3, have the function of facilitating relative centring thereof and therefore may be advantageously maintained also in all the following examples.

**[0035]** The expression "cylindrical" is understood as meaning the shape of any solid form which has a side surface with parallel generatrix lines, even though not delimiting the cylinder commonly known as a straight cylinder.

**[0036]** In greater detail, in accordance with the first example of embodiment, each first opening 5, 6 is shaped

in the manner of a groove, which extends in a direction X parallel to the joining face of the section 2, 3 from its outer perimeter and extends inside the said section 2, 3 from its face with a widened portion able to define an undercut 18.

[0037] The seat 7 obtained from the first grooves 5, 6 thus formed receives a correspondingly shaped pin 8 with solid flanges 19 which widen in the form of a wedge from the middle section so as to be gripped in the undercuts 18 of the grooves 5, 6 and thus keep the sections 2, 3 joined together.

[0038] In the first example of the accompanying figures, three pins 8 are envisaged. Obviously a different number of pins 8 may be envisaged without thereby departing from the scope of protection of the present patent.

[0039] Moreover, in accordance with this first example, the pins 8 are inserted in seats 7 which extend in directions X transverse to the plane of lie of the frame.

[0040] Alternatively, the joint 1 according to the second example of embodiment shown in Figures 6, 7a and 7b is provided with a single pin 8 which is inserted inside the seat 7 parallel to the plane of lie in a direction indicated by X'.

[0041] Advantageously, insertion is performed from the outside of the frame towards the inside. In both the examples of embodiment described, the seats are blind and do not affect the side of the section opposite to the starting side from which they extend.

[0042] In accordance with the third embodiment shown in Figures 8, 9a and 9b, the ends 8' and 8" of the pin 8 are arranged inside transverse holes 20 formed in internally hollow and threaded cylindrical bushes 21 inserted inside channels 22 formed in the respective sections 2, 3. The said ends 8' and 8" of the pin 8 are provided with elongated eyelets 23 in the direction of extension of the pins 8. These eyelets 23 are situated at a relative distance from each other able to ensure that their engagement with suitable grub screws 24, screwed into the internal thread of the bushes 21, forces the pin 8 to move the two sections 2, 3 towards each other.

[0043] In accordance with the fourth embodiment shown in Figures 10, 11a and 11b, the pin 8 has the form of a circular ring and is inserted inside annular grooves 5, 6 formed by means coring on the joining faces of the sections and defining a pair of cylindrical shapes 25.

[0044] It is envisaged using a screw 26 arranged to pass through the cylindrical shapes 25 so as to join mechanically together the sections 2, 3 already constrained by the pin 8.

[0045] In accordance with the fifth embodiment shown in Figures 8, 9a and 9b, the pin 8 is provided internally with a through-cavity 27 which tapers from the ends towards the middle section so as to define a double conicity.

[0046] The abovementioned cavity 27 is passed through by a screw 28 and by a nut screw 29, which both have an elongated shape, which are inserted inside holes formed in the respective sections 2, 3 and which, mating with each other, force with the head 30 the pin 8 to expand

its grip inside the seat 8, thereby mechanically retaining and fastening together the two sections 2, 3.

[0047] The invention thus conceived therefore achieves the predefined objects.

5 [0048] Obviously, it may assume, in its practical embodiment, also forms and configurations different from that illustrated above, without thereby departing from the present scope of protection.

10 [0049] Moreover, all the details may be replaced by technically equivalent parts and the dimensions, the forms and the materials used may be of any nature, according to requirements.

## 15 Claims

1. Corner joint for sections of door and window frames, comprising a first and a second section which can be joined together to form a frame, along respective joining faces divided by a joining plane and united by means of fixing means which envisage that said joining faces have, formed in them, in opposite positions first openings able to form a seat which extends on either side of the joining plane and which comprise at least one pin able to engage inside said seat so as to fix said sections together; **characterized in that** it comprises at least one connection element arranged between said first and second section along said joining plane and having second openings positioned opposite and so as to connect together said first opposite openings.
2. Corner joint for sections of door and window frames according to Claim 1, **characterized in that** said connection element is substantially a plate shaped in the manner of the profile of said face.
3. Corner joint for sections of door and window frames according to Claim 1 or 2, **characterized in that** said connection element has at least one first portion with a visible edge on one side of said frame.
4. Corner joint for sections of door and window frames according to any one of the preceding claims, **characterized in that** said connection element has at least one second resiliently yielding portion able to be compressed along the joint so as to increase the seal between said sections.
5. Corner joint for sections of door and window frames according to Claims 3 and 4, **characterized in that** said connection element is made of plastic material by means of co-moulding of said two portions, the first one of which being more rigid than the second one.
6. Corner joint for sections of door and window frames according to any one of the preceding claims, **char-**

- acterized in that** said connection element comprises at least two cylindrical pins projecting from its two faces in opposite directions and able to be inserted with mechanical grip inside corresponding blind holes formed in the faces of the two sections in a position corresponding to that of the pins. 5
7. Corner joint for sections of door and window frames, according to any one of the preceding claims, **characterized in that** each said opening is shaped in the form of a groove extending in a direction parallel to the joining face from its outer perimeter and extending inside said section with at least one widened portion able to define at least one undercut; said seat obtained by the grooves of the opposite faces being able to receive said pin which is shaped so as to match said seat and is able to join together said sections, gripping by means of its widened flanges inside the undercuts of said grooves. 10  
15  
20
8. Corner joint for sections of door and window frames according to Claim 7, **characterized in that** said pin is inserted transversely with respect to said plane of lie. 25
9. Corner joint for sections of door and window frames according to Claim 7, **characterized in that** said pin is inserted parallel to said plane of lie.
10. Corner joint for sections of door and window frames according to any one of Claims 1-6, **characterized in that** said pin is provided internally with a through-cavity having at least one conicity, which cavity is passed through by a screw and by a nut screw which are inserted inside holes formed in the respective sections and which, joining together, force said pin to grip inside said seat. 30  
35
11. Corner joint for sections of door and window frames according to any one of Claims 1-6, **characterized in that** the ends of said pin are arranged inside transverse holes of bushes which are inserted inside channels formed in the respective sections and are provided with elongated eyelets able to receive grub screws engaging inside said bushes so as to force the pin to move the two sections axially towards each other. 40  
45
12. Corner joint for sections of door and window frames according to any one of Claims 1-6, **characterized in that** said pin has the form of a circular ring and is inserted inside annular grooves formed by means of coring on said joining faces delimiting a pair of cylindrical shapes, a screw being provided so as to pass through the cylindrical shapes so as to force gripping of said sections. 50  
55

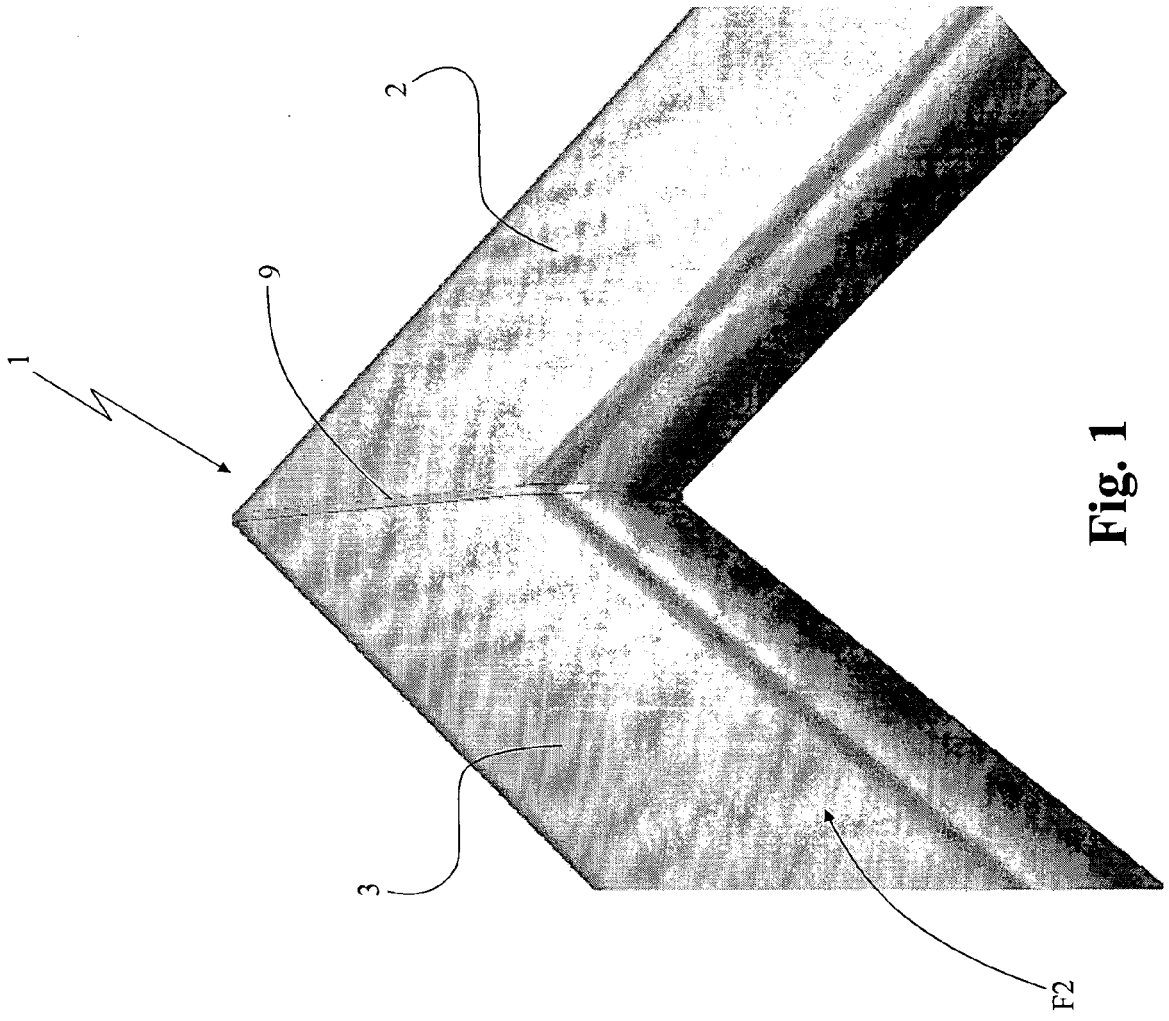

**Fig. 1**

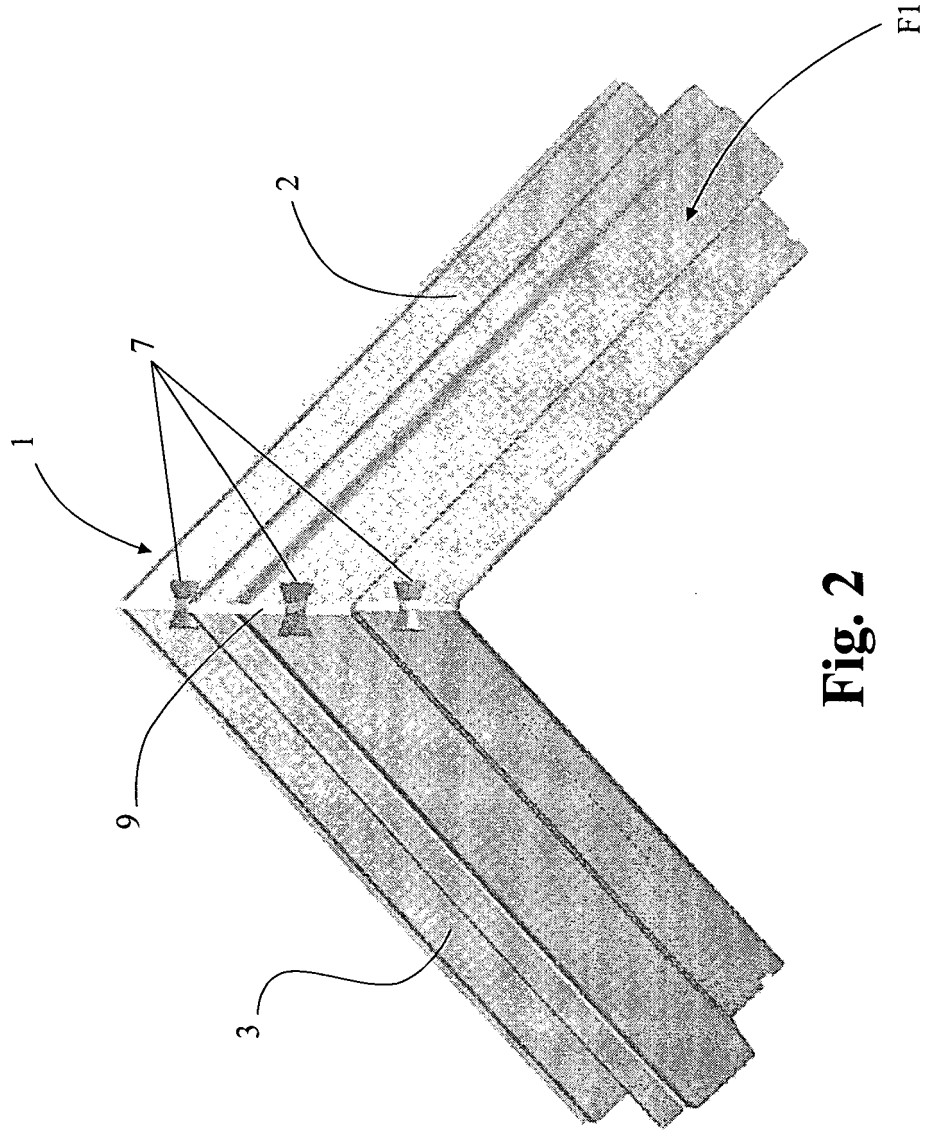

**Fig. 2**

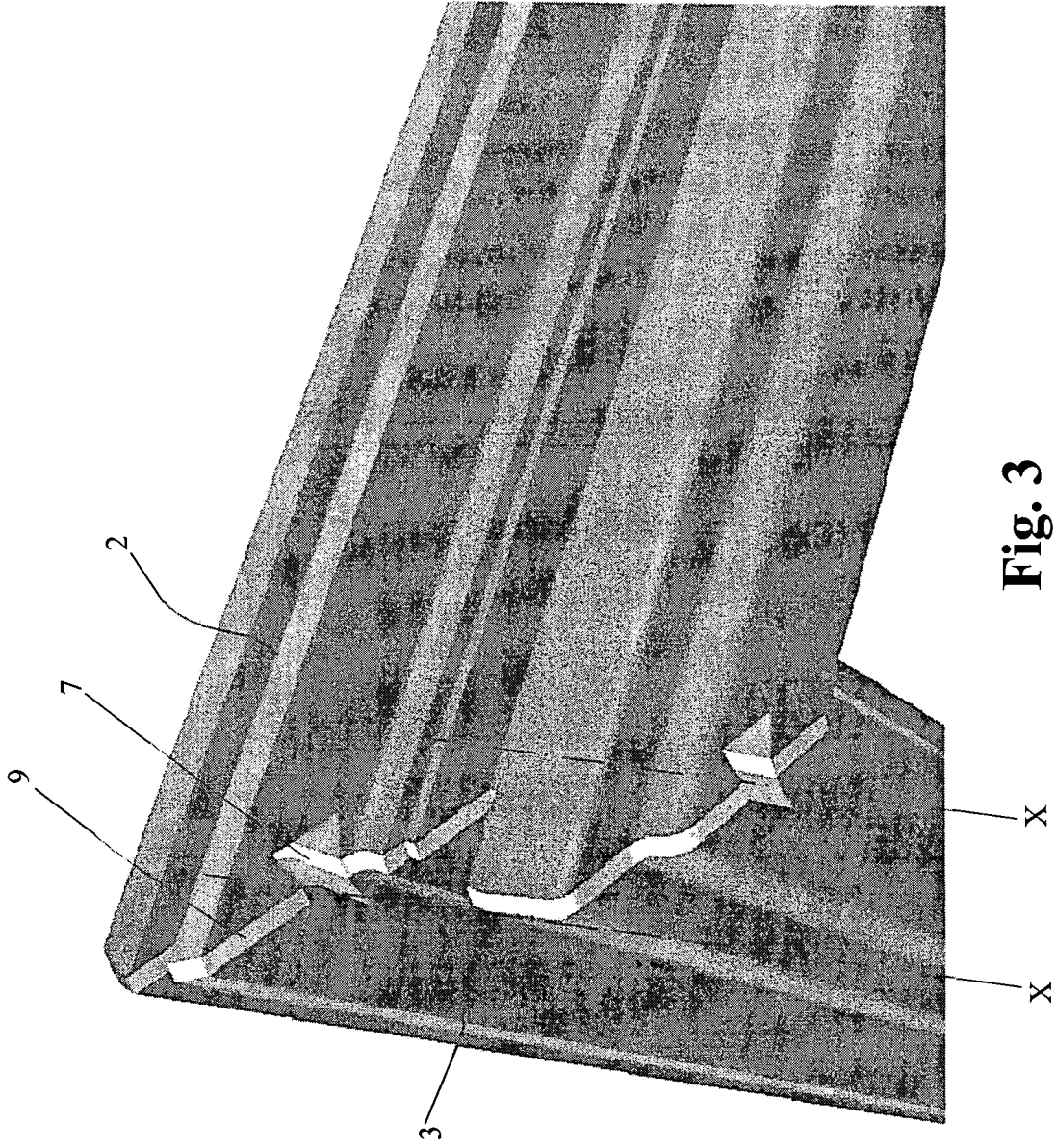

Fig. 3

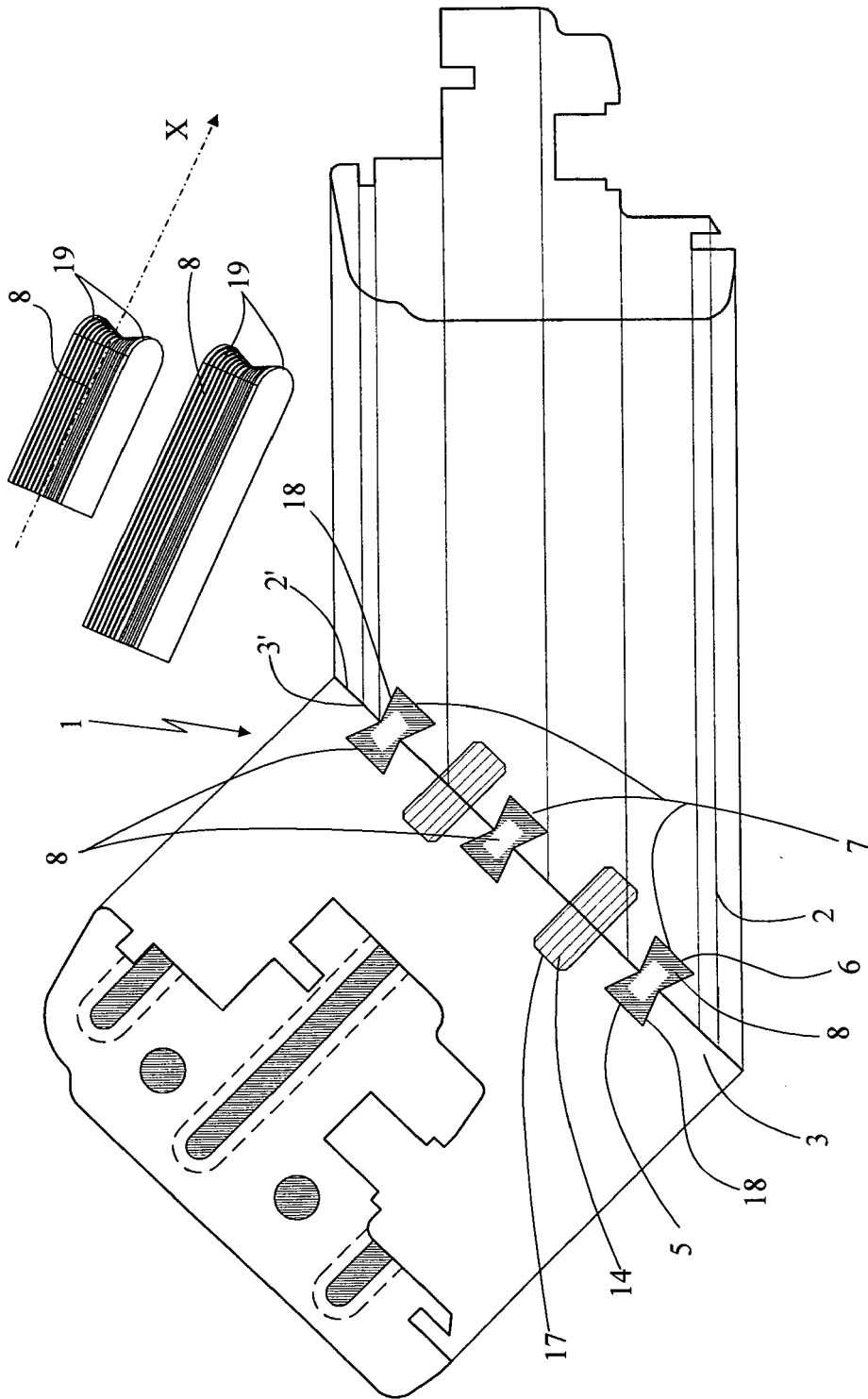
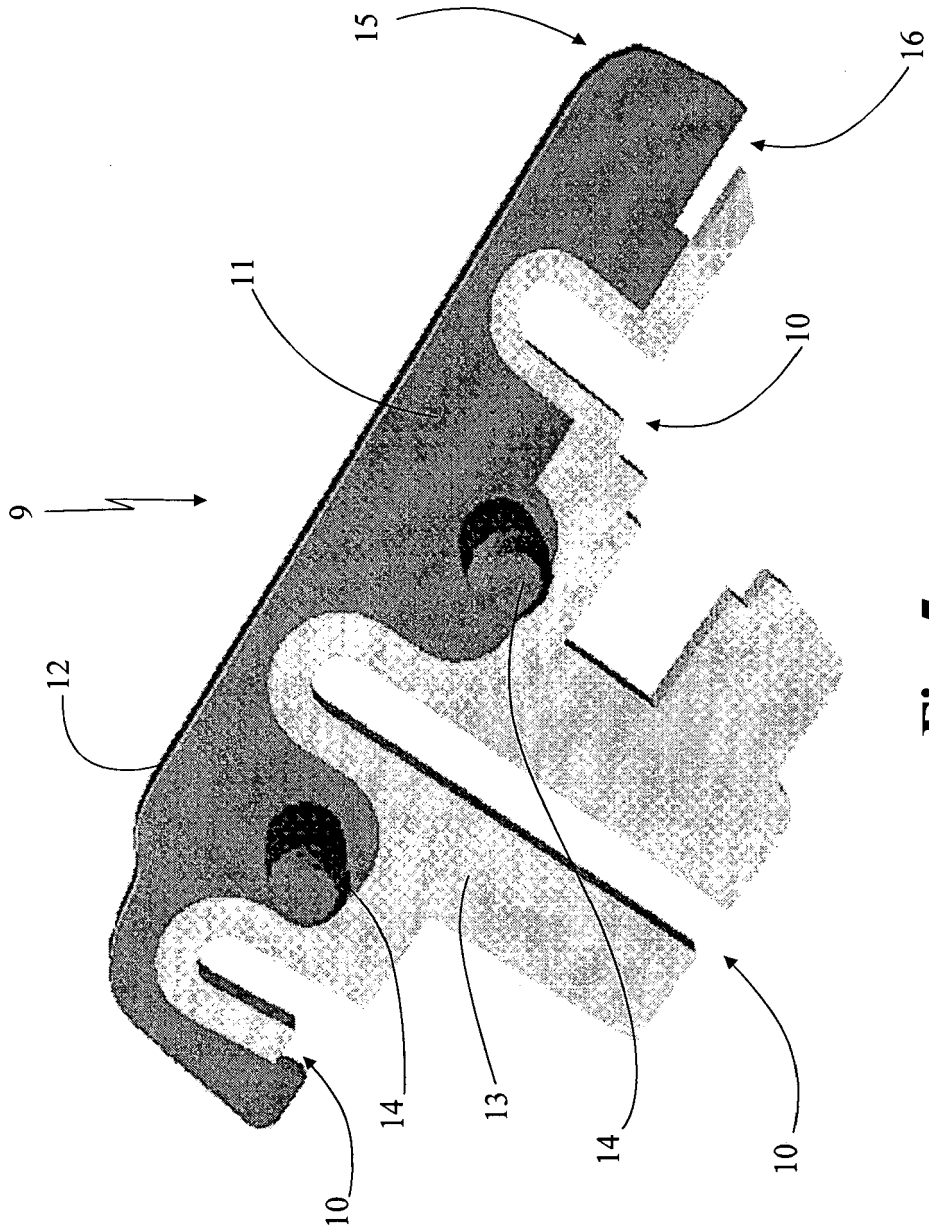

Fig. 4



**Fig. 5a**

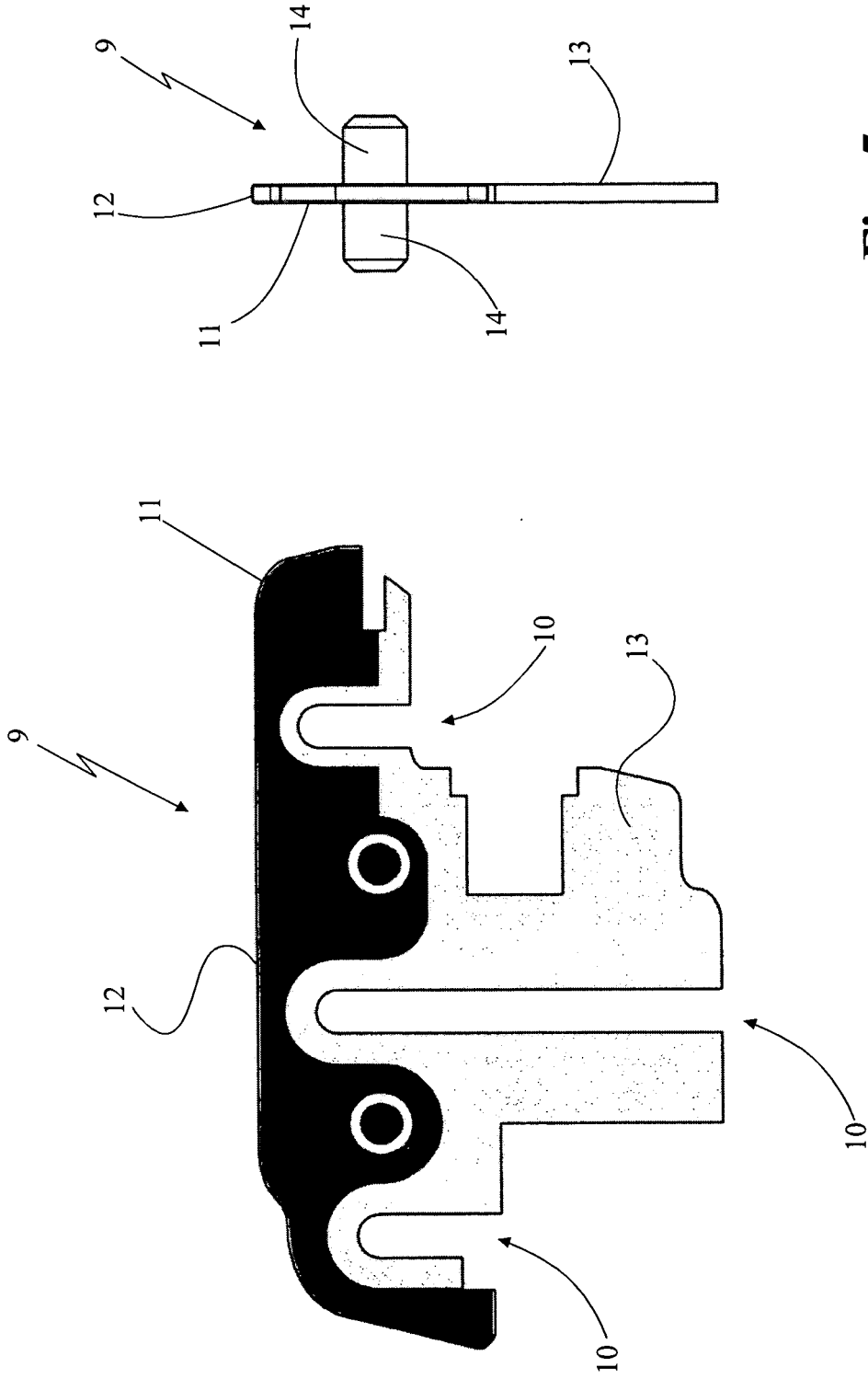
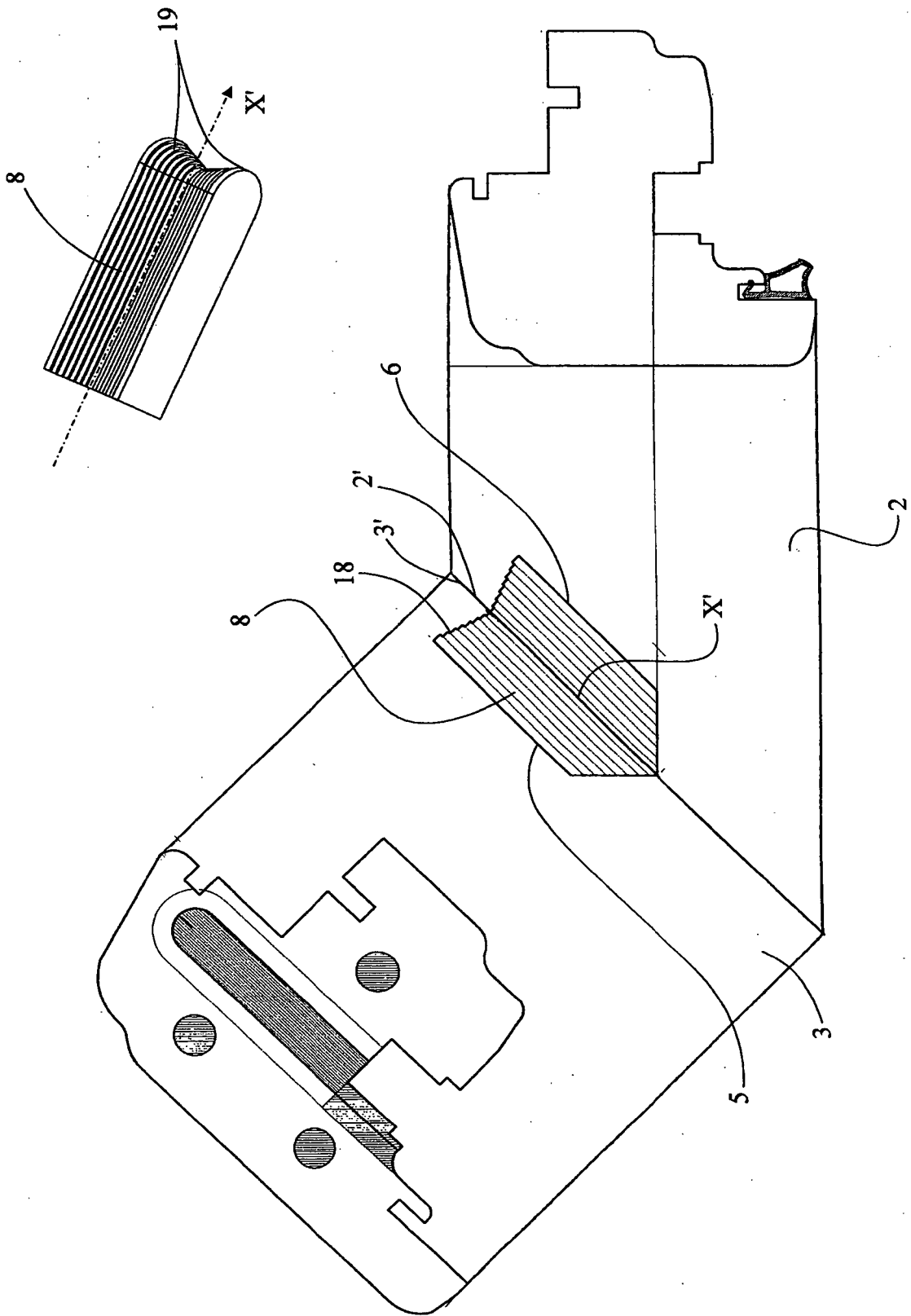
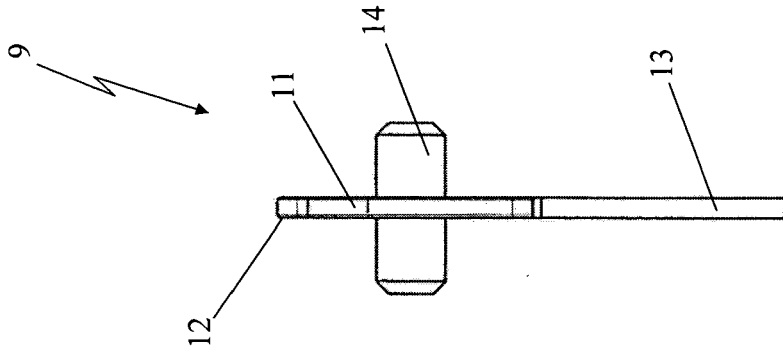

Fig. 5c

Fig. 5b



**Fig. 6**



**Fig. 7b**

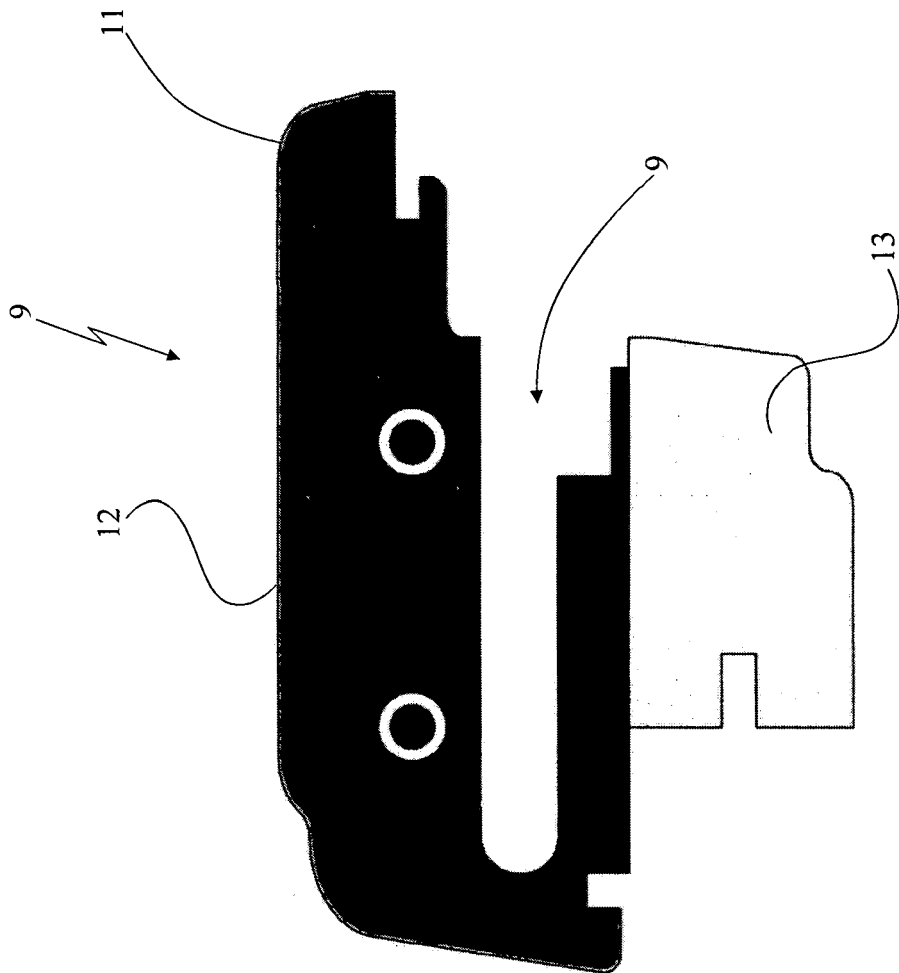

**Fig. 7a**

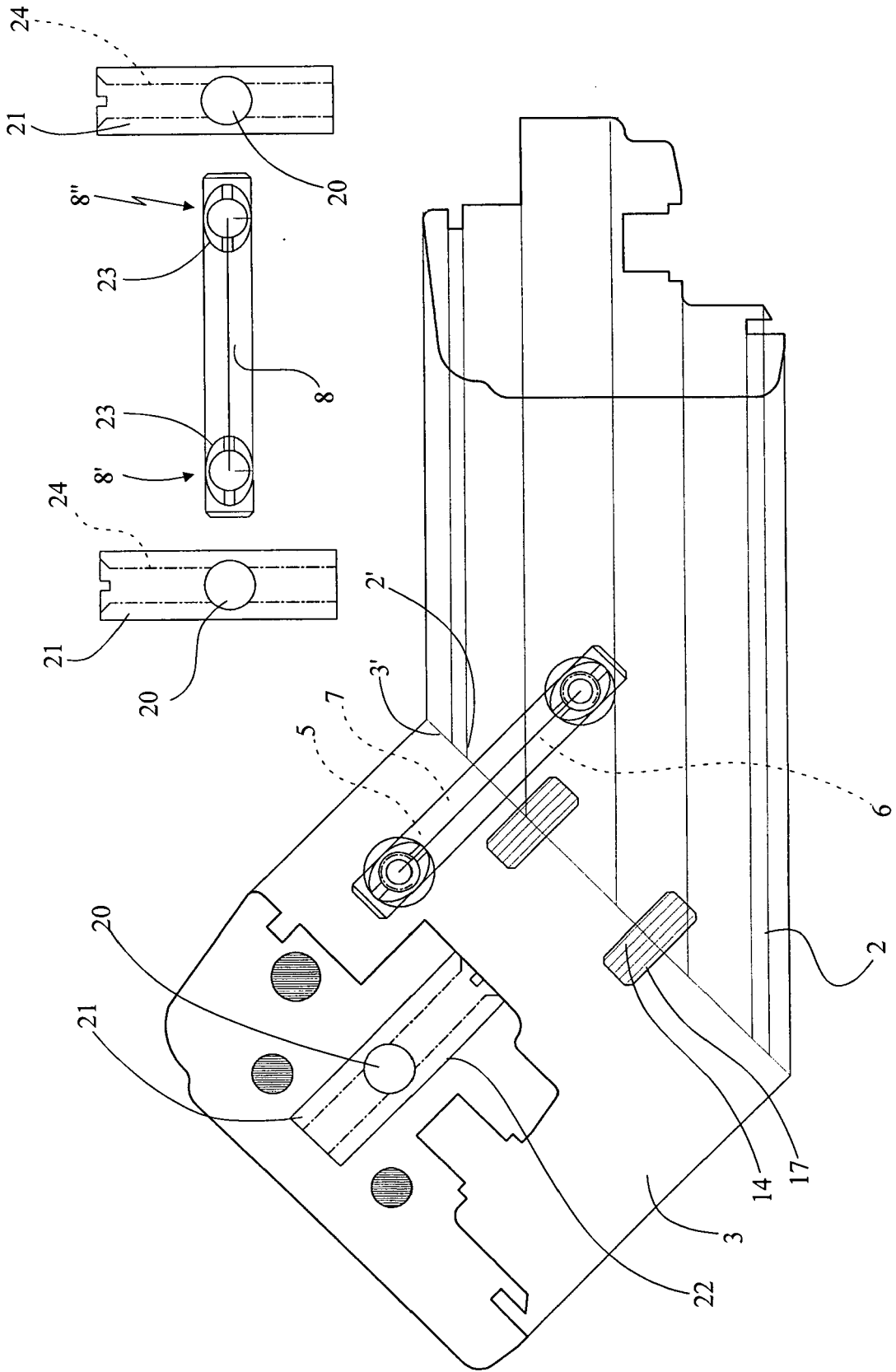
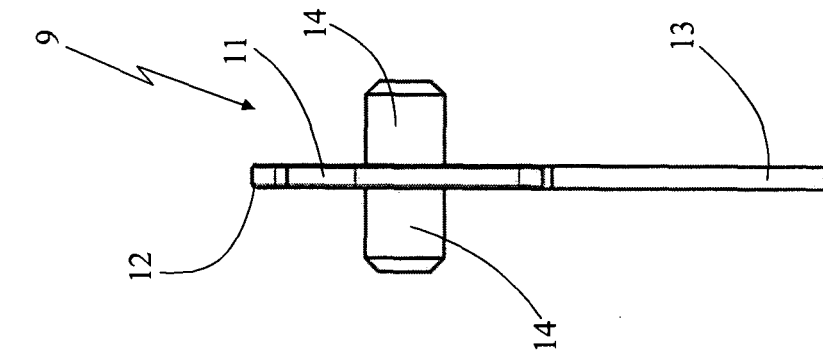
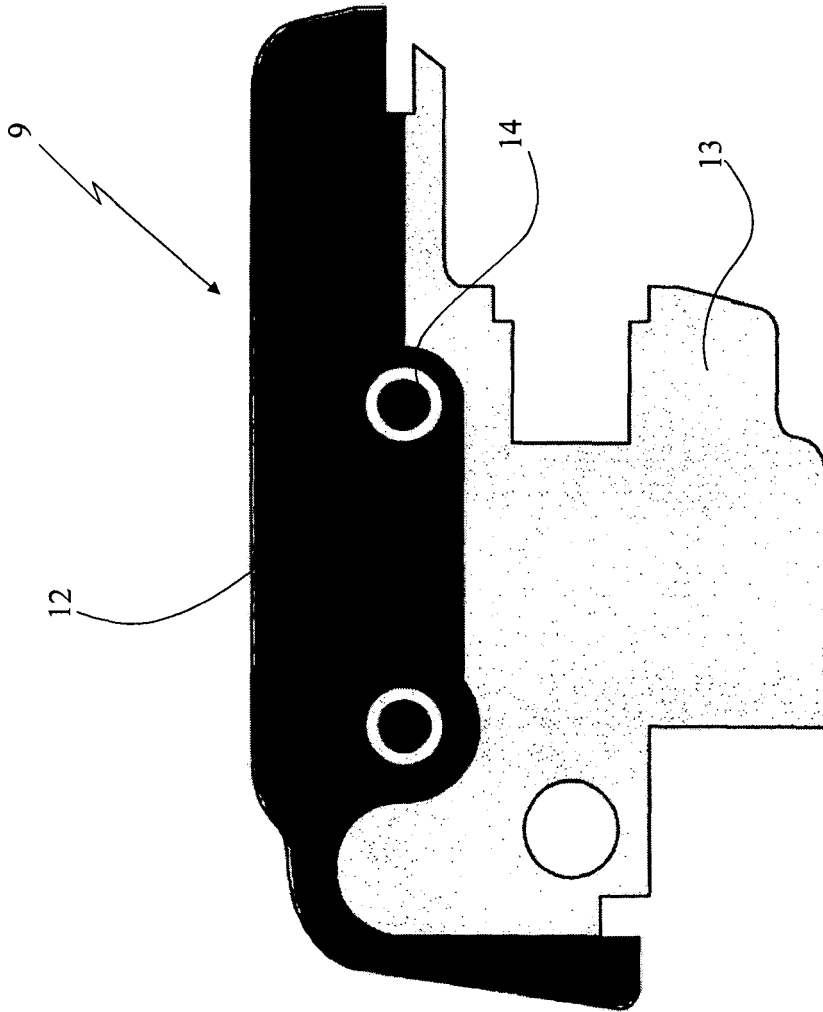

Fig. 8



**Fig. 9b**



**Fig. 9a**

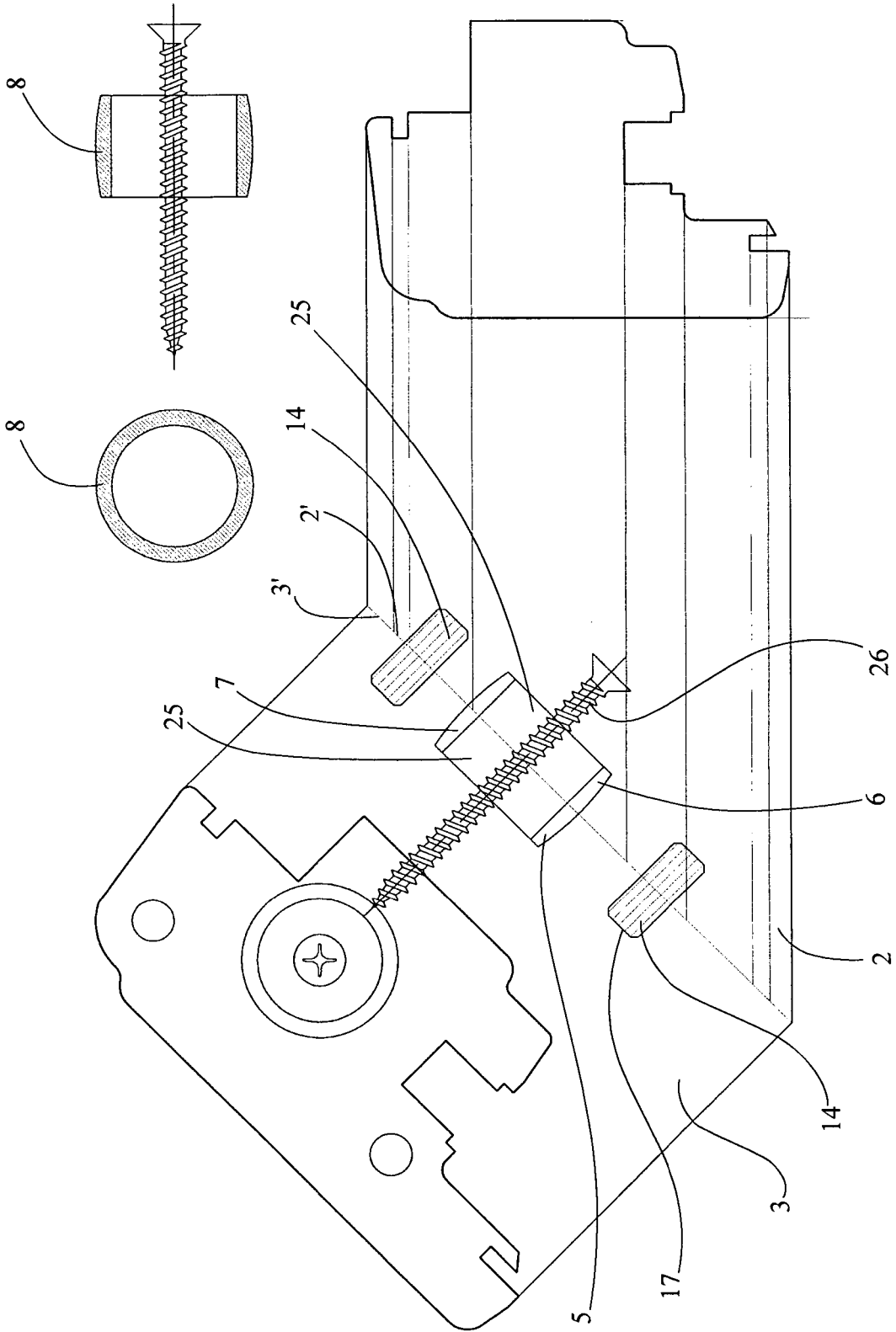

Fig. 10

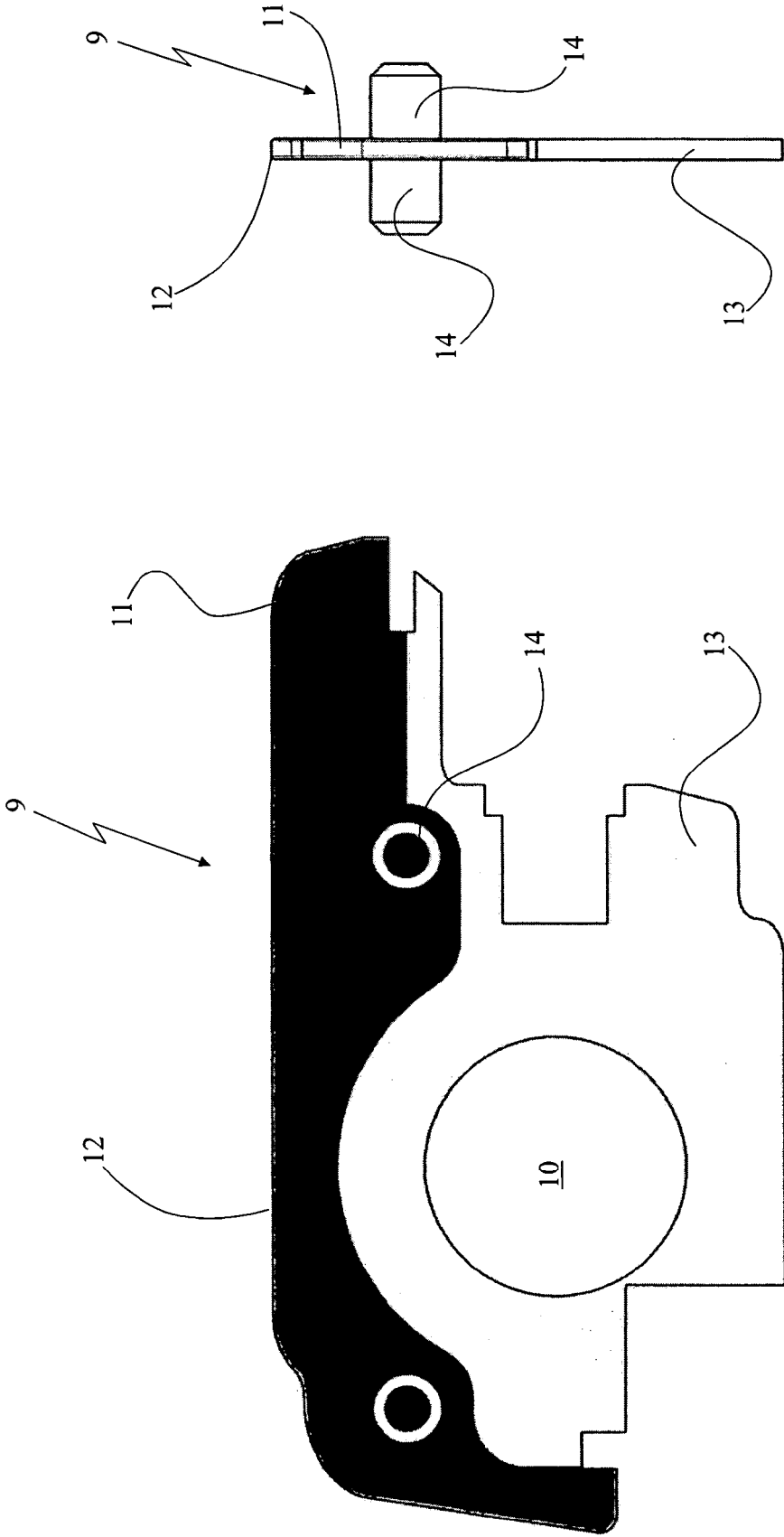

Fig. 11b

Fig. 11a

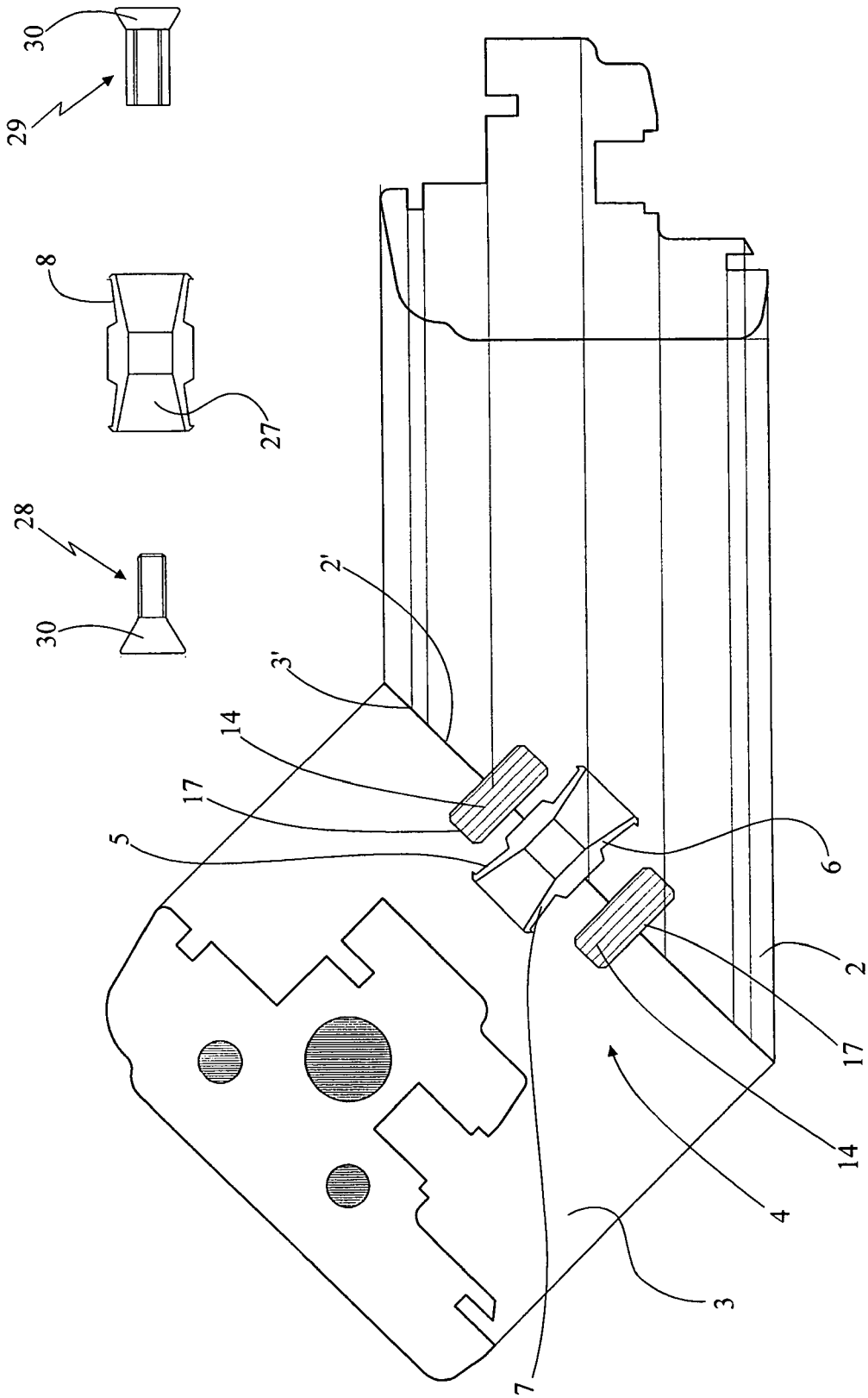
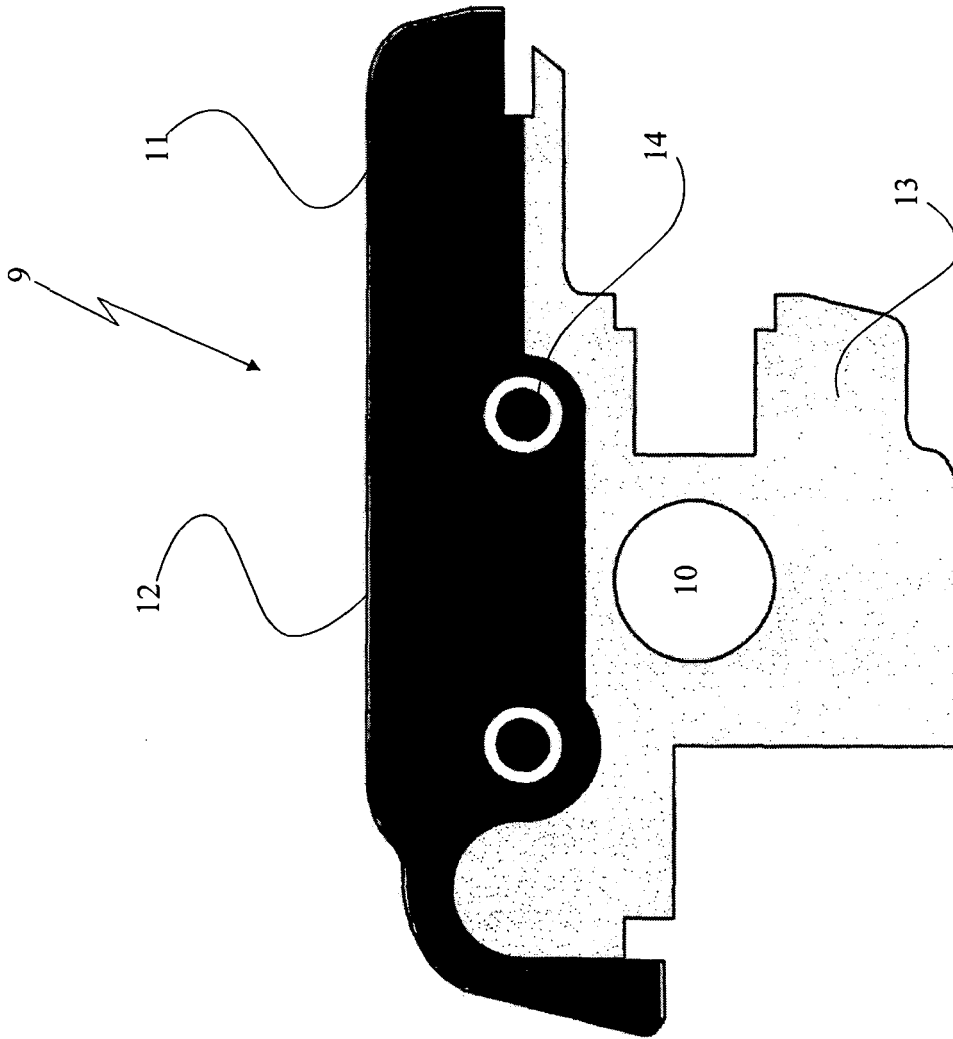
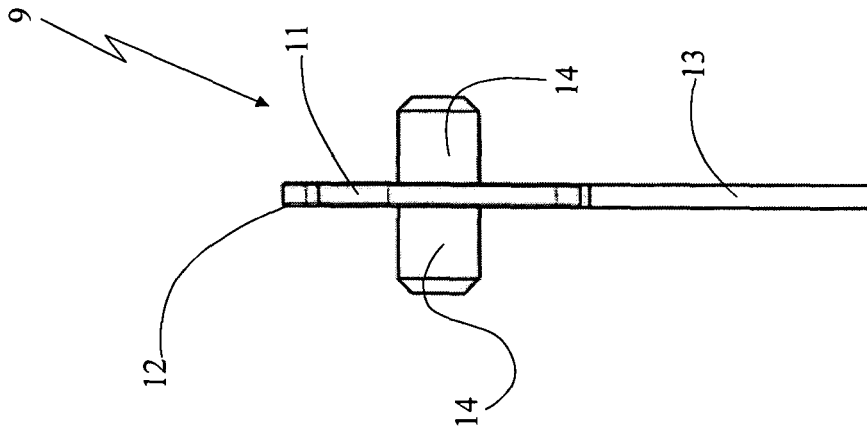

Fig. 12



**Fig. 13a**



**Fig. 13b**



DOCUMENTS CONSIDERED TO BE RELEVANT			
Category	Citation of document with indication, where appropriate, of relevant passages	Relevant to claim	CLASSIFICATION OF THE APPLICATION (IPC)
X	DE 200 21 743 U1 (HACHTEL STEFFEN [DE]) 26 July 2001 (2001-07-26) * claims 1,4,5 * * figures 1-5 *	1-4	INV. E06B3/96 E06B3/984
Y		6-9,11, 12	
Y	----- DE 72 33 867 U (HETTICH F KG) 11 January 1973 (1973-01-11) * claims 1,8 * * figures 6-8 *	6	
Y	----- US 5 603 586 A (WETSEL JOHN L [US] ET AL) 18 February 1997 (1997-02-18) * figure 4 *	7,8	
Y	----- EP 0 057 307 A (FAIRCLOUGH HARRY JOINERY LTD [GB]) 11 August 1982 (1982-08-11) * claim 1 * * figure 4 *	7,9	
Y	----- DE 32 29 390 A1 (FAIPARI KUTATO INTEZET [HU]) 5 May 1983 (1983-05-05) * figures 7-11 *	11	
Y	----- WO 2006/043908 A (GOVZE ANTON [SI]) 27 April 2006 (2006-04-27) * figures 1,2 *	12	E06B
X	----- EP 0 860 575 A2 (SCHUECO INT KG [DE]) 26 August 1998 (1998-08-26) * claims 1,3-5 * * figures 2-11 *	1-3	
	----- -/--		
The present search report has been drawn up for all claims			
Place of search <b>Munich</b>		Date of completion of the search <b>16 April 2007</b>	Examiner <b>Tänzler, Ansgar</b>
<p>CATEGORY OF CITED DOCUMENTS</p> <p>X : particularly relevant if taken alone                      Y : particularly relevant if combined with another document of the same category                      A : technological background                      O : non-written disclosure                      P : intermediate document</p> <p>T : theory or principle underlying the invention                      E : earlier patent document, but published on, or after the filing date                      D : document cited in the application                      L : document cited for other reasons</p> <p>.....                      &amp; : member of the same patent family, corresponding document</p>			

3  
EPO FORM 1503 03.82 (P04C01)



DOCUMENTS CONSIDERED TO BE RELEVANT			
Category	Citation of document with indication, where appropriate, of relevant passages	Relevant to claim	CLASSIFICATION OF THE APPLICATION (IPC)
X	FR 2 617 081 A1 (PERRON GUY [FR]; FERREYROLLES MICHELE [FR]) 30 December 1988 (1988-12-30) * claim 1 * * figures 1-4 *	1-3	
X	US 2003/005644 A1 (REITHMEYER JOSEPH GUY [US] ET AL) 9 January 2003 (2003-01-09) * claims 1,4,5 * * figure 1 *	1,3,4	
X	DE 24 20 688 A1 (BIFFAR OSKAR D) 6 November 1975 (1975-11-06) * claim 1 * * figure 1 *	1,3	
Y	DE 102 54 013 A1 (HOFFMANN MASCHB GMBH [DE]) 3 June 2004 (2004-06-03) * figures 1,2 *	7,8	
			TECHNICAL FIELDS SEARCHED (IPC)
The present search report has been drawn up for all claims			
Place of search Munich		Date of completion of the search 16 April 2007	Examiner Tänzler, Ansgar
CATEGORY OF CITED DOCUMENTS X : particularly relevant if taken alone Y : particularly relevant if combined with another document of the same category A : technological background O : non-written disclosure P : intermediate document		T : theory or principle underlying the invention E : earlier patent document, but published on, or after the filing date D : document cited in the application L : document cited for other reasons ..... & : member of the same patent family, corresponding document	

3  
EPO FORM 1503 03/02 (P04C01)

**ANNEX TO THE EUROPEAN SEARCH REPORT  
ON EUROPEAN PATENT APPLICATION NO.**

EP 06 42 5639

This annex lists the patent family members relating to the patent documents cited in the above-mentioned European search report. The members are as contained in the European Patent Office EDP file on The European Patent Office is in no way liable for these particulars which are merely given for the purpose of information.

16-04-2007

Patent document cited in search report	Publication date	Patent family member(s)	Publication date	
DE 20021743	U1	26-07-2001	EP 1217162 A2 ES 2222299 T3	26-06-2002 01-02-2005
DE 7233867	U		NONE	
US 5603586	A	18-02-1997	NONE	
EP 0057307	A	11-08-1982	NONE	
DE 3229390	A1	05-05-1983	DD 210324 A1 HU 181385 B	06-06-1984 28-07-1983
WO 2006043908	A	27-04-2006	SI 21890 A	30-04-2006
EP 0860575	A2	26-08-1998	AT 250713 T DE 19707095 A1	15-10-2003 27-08-1998
FR 2617081	A1	30-12-1988	PT 87853 A	31-05-1989
US 2003005644	A1	09-01-2003	CA 2392658 A1 MX PA02006726 A	06-01-2003 16-07-2004
DE 2420688	A1	06-11-1975	NONE	
DE 10254013	A1	03-06-2004	NONE	

EPO FORM P0459

For more details about this annex : see Official Journal of the European Patent Office, No. 12/82

**REFERENCES CITED IN THE DESCRIPTION**

*This list of references cited by the applicant is for the reader's convenience only. It does not form part of the European patent document. Even though great care has been taken in compiling the references, errors or omissions cannot be excluded and the EPO disclaims all liability in this regard.*

**Patent documents cited in the description**

- EP 370334 A [0007] [0008]
- FR 1175665 [0007] [0008]
- BE 903745 [0007]
- US 1793185 A [0007]
- US 4183187 A [0007]
- GB 2076924 A [0007]
- AT 2927942 [0007]