

(12) STANDARD PATENT
(19) AUSTRALIAN PATENT OFFICE

(11) Application No. **AU 2006264122 B2**

- (54) Title
Packing for infusion set and method of applying an infusion set
- (51) International Patent Classification(s)
A61M 5/158 (2006.01)
- (21) Application No: **2006264122** (22) Date of Filing: **2006.06.08**
- (87) WIPO No: **WO07/000162**
- (30) Priority Data
- | (31) Number | (32) Date | (33) Country |
|--------------------|-------------------|--------------|
| 60/694,547 | 2005.06.28 | US |
| PA200500958 | 2005.06.28 | DK |
- (43) Publication Date: **2007.01.04**
- (44) Accepted Journal Date: **2010.12.02**
- (71) Applicant(s)
Unomedical A/S
- (72) Inventor(s)
Toft Olsen, Jesper;Svendstrup, May Britt;Gyrn, Steffen;Ahman, Carl Johan Daniel;Wesseltoft Mogensen, Lasse
- (74) Agent / Attorney
Shelston IP, Level 21 60 Margaret Street, Sydney, NSW, 2000
- (56) Related Art
US 6355021
EP 1475113
US 5545143
WO 2001/072353
US 2003/130619
US 2005/107743

(19) World Intellectual Property Organization
International Bureau



(43) International Publication Date
4 January 2007 (04.01.2007)

PCT

(10) International Publication Number
WO 2007/000162 A3

(51) International Patent Classification:
A61M 5/158 (2006.01)

(74) Agent: ZACCO DENMARK A/S; Hans Bekkevolds Allé 7, DK-2900 Hellerup (DK).

(21) International Application Number:
PCT/DK2006/000318

(81) Designated States (unless otherwise indicated, for every kind of national protection available): AE, AG, AL, AM, AT, AU, AZ, BA, BB, BG, BR, BW, BY, BZ, CA, CH, CN, CO, CR, CU, CZ, DE, DK, DM, DZ, EC, EE, EG, ES, FI, GB, GD, GE, GH, GM, HR, HU, ID, IL, IN, IS, JP, KE, KG, KM, KN, KP, KR, KZ, LC, LK, LR, LS, LT, LU, LV, LY, MA, MD, MG, MK, MN, MW, MX, MZ, NA, NG, NI, NO, NZ, OM, PG, PH, PL, PT, RO, RS, RU, SC, SD, SE, SG, SK, SL, SM, SY, TJ, TM, TN, TR, TT, TZ, UA, UG, US, UZ, VC, VN, ZA, ZM, ZW.

(22) International Filing Date: 8 June 2006 (08.06.2006)

(25) Filing Language: English

(26) Publication Language: English

(30) Priority Data:
PA200500958 28 June 2005 (28.06.2005) DK
60/694,547 28 June 2005 (28.06.2005) US

(84) Designated States (unless otherwise indicated, for every kind of regional protection available): ARIPO (BW, GH, GM, KE, LS, MW, MZ, NA, SD, SL, SZ, TZ, UG, ZM, ZW), Eurasian (AM, AZ, BY, KG, KZ, MD, RU, TJ, TM), European (AT, BE, BG, CH, CY, CZ, DE, DK, EE, ES, FI, FR, GB, GR, HU, IE, IS, IT, LT, LU, LV, MC, NL, PL, PT, RO, SE, SI, SK, TR), OAPI (BF, BJ, CF, CG, CI, CM, GA, GN, GQ, GW, ML, MR, NE, SN, TD, TG).

(71) Applicant (for all designated States except US): UN-OMEDICAL A/S [DK/DK]; Birkerød Kongevej 2, DK-3460 Birkerød (DK).

(72) Inventors; and

(75) Inventors/Applicants (for US only): WESELTOFT MOGENSEN, Lasse [DK/DK]; Jacob Bulls Alle 100, 1., DK-2860 Søborg (DK). TOFT OLSEN, Jesper [DK/DK]; Nr. Voldgade 46, 4.th., DK-1358 Copenhagen K (DK). AHMAN, Carl, Johan, Daniel [SE/SE]; Sofielundsvägen 23D, S-214 25 Malmö (SE). SVENDSTRUP, May, Britt [DK/DK]; Tværvej 2, DK-4130 Viby Sjælland (DK). GYRN, Steffen [DK/DK]; Schaldemosevej 6, 1.tv., DK-4100 Ringsted (DK).

Published:

— with international search report

(88) Date of publication of the international search report:
1 March 2007

For two-letter codes and other abbreviations, refer to the "Guidance Notes on Codes and Abbreviations" appearing at the beginning of each regular issue of the PCT Gazette.

(54) Title: PACKING FOR INFUSION SET AND METHOD OF APPLYING AN INFUSION SET

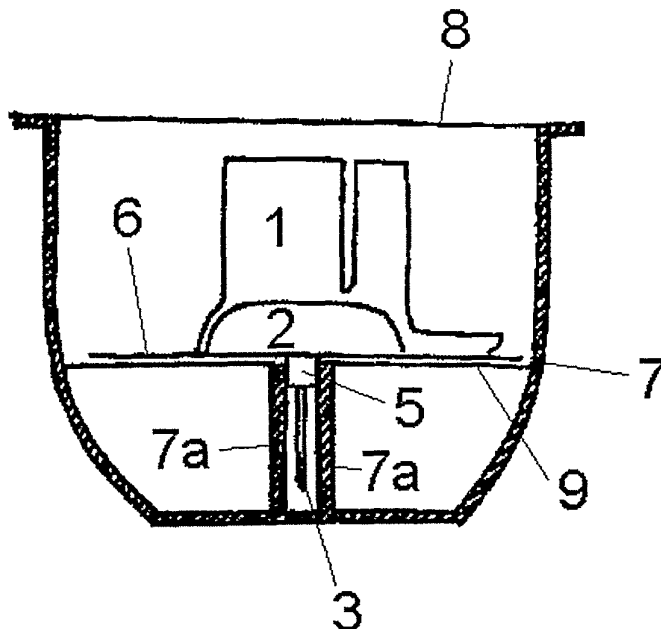

(57) Abstract: The present invention relates to a packing for an infusion set. An infusion set for intermittent or continuous administration of a therapeutical substance, such as insulin, comprises an infusion part having a cannula penetrating the skin of a patient and a connector which connects the infusion part with a medical device such as an adaptor for a syringe or an insulin pump. The insertion of the infusion part will be performed with an insertion needle which is delivered together with the infusion part under sterile conditions. The packaging comprises an impenetrable part (7) protecting the surroundings from the insertion needle and a removal part (8) which is to be removed by the user before applying the infusion part. The inner surface of the impenetrable part (7) is provided with means (7a) for releasable retaining at least a part of the infusion set.

WO 2007/000162 A3

Packing for infusion set and Method of applying an infusion set

Technical field

5 The present invention relates to a packaging for an infusion set. An infusion set for intermittent or continuous administration of a therapeutical substance, such as insulin, comprises an infusion part having a cannula penetrating the skin of a patient and a connector which connects the infusion part with a medical device such as an adaptor for a syringe or an insulin pump. The insertion of the infusion part will be performed with an insertion needle which
10 is delivered together with the infusion part under sterile conditions.

Background of the invention

15 Any discussion of the prior art throughout the specification should in no way be considered as an admission that such prior art is widely known or forms part of common general knowledge in the field.

20 US 5.968.011-A relates to a subcutaneous low-profile infusion set for administrating a medication or a therapeutic fluid to a patient. It would be possible to apply this infusion set according to the present invention.

25 US 6.355.021-B1 relates to a medical puncturing device. This device comprises a rigid needle mounted in a needle hub (2), and the needle hub comprises a handle part (3) and a shield part (4). This device could be used to insert an infusion set as described in US 5.968.011-A.

30 US 2003/00130619 A1 relates to an insertion device and an insertion set. Figures 35 to 40 and the corresponding text ([0099]-[0107]) describe an insertion device which could be applied in connection with the present invention.

It is an object of the present invention to overcome or ameliorate at least one of the disadvantages of the prior art, or to provide a useful alternative.

Description of invention

5 Advantageously, the invention in at least one preferred embodiment makes the insertion of an infusion device easier, more flexible and convenient for the patient. According to at least one preferred embodiment of the invention it is advantageously possible to combine a standard infusion device with, for example, an inserter for automatic insertion or a handle for manual insertion
10 as the inventive packaging assures the stability which is necessary in order to keep the infusion set and needle hub in position while a secondary device in the form of a handle or an inserter, chosen by the patient, is pushed against it and connected to it. When the packaging is used as a sort of handling device during the insertion procedure, the contamination of the
15 infusion device is also kept at a minimum.

It is not essential whether the secondary device is connected releasably or unreleasably to the infusion device while connected to it as both possibilities have their advantages, but the secondary device should form a stronger
20 connection with the infusion set than the infusion set forms with the packaging according to the invention in order for the user to remove the infusion set from the packaging by simply pulling the secondary device away from the packaging.

25 According to a first aspect, the invention provides a packaging for an infusion set comprising an infusion part and a needle hub where the needle hub is combined with an insertion needle, which packaging comprises a support part for holding the infusion part and the needle hub, an impenetrable part protecting the surroundings from the insertion needle and a removable part
30 which is to be removed by the user before applying the infusion set wherein

the inner part of the impenetrable part comprises retaining means for releasably retaining at least a part of the infusion set.

5 Unless the context clearly requires otherwise, throughout the description and the claims, the words "comprise", "comprising", and the like are to be construed in an inclusive sense as opposed to an exclusive or exhaustive sense; that is to say, in the sense of "including, but not limited to".

10 Preferably the proximal side of the infusion set is provided with an adhesive, and the adhesive can be covered with a release layer.

15 In one embodiment of the invention the release layer covering the adhesive is partly fastened to the impenetrable part or fastened to a part being connected to the impenetrable part, an appropriate release layer for an adhesive sheet material is known from WO 2004/087240. This will cause the release layer to be removed when the infusion set and the needle hub is removed from the packaging. According to this embodiment the release layer can have the form of a band where one end of the band is fastened to the impenetrable part or fastened to a part being integrated with the impenetrable part.
20

25 In one embodiment of the invention the impenetrable part is made of a hard material. Preferably the impenetrable part is made of polypropylene (PP), polyethylene (PE HD) or PVC.

30 In one embodiment of the invention the needle hub is on its distal side provided with means for retaining a device. Preferably the needle hub is provided with means for retaining an inserter. More preferred the needle hub can take up and retain an inserter when the inserter is pushed towards the needle hub from the distal side. An inserter is not shown in the figures but a

suitable inserter is described in US patent application no. 2003/0130619 figs. 35 – 38.

5 In a preferred embodiment the infusion set is releasably retained by the retaining means formed as an integrated part of the impenetrable part of the packaging. In this embodiment the infusion part can be provided with corresponding means which are releasably connected to the retaining means. According to this embodiment the retaining means can be formed as walls standing from the impenetrable part in an angle between -45° and 45°
10 where 0° is orthogonal to the proximal surface of the impenetrable part, and the corresponding means can be formed as a cylinder or a truncated cone integrated with the infusion part.

15 In a preferred embodiment the corresponding means comprise a cylinder or a truncated cone formed by a groove or recess in the infusion part making it possible for the proximal end of the corresponding means to be aligned to the proximal surface of the infusion part.

20 In another embodiment the retaining means are formed of a relatively soft material which material can be penetrated by the insertion needle and which soft material is connected unreleasably to the impenetrable part of the packaging.

25 In a preferred embodiment a support part parallel to the proximal surface of the infusion set is fastened to the impenetrable part or formed as an integrated part of the impenetrable part.

30 In another preferred embodiment the retaining means comprises an opening for the needle and a support part parallel to the proximal surface of the infusion set. In this embodiment the corresponding means can comprise a

cylinder or a truncated cone protruding from the proximal surface of the infusion part.

5 According to a second aspect, the invention provides a method of applying an infusion set comprising an infusion part and a needle hub where the needle hub is combined with an insertion needle, which method comprises the following steps:

- removing the removable part of the packaging,
- fastening a device to the needle hub,
- 10 - removing the infusion set from the impenetrable part of the packaging by pulling the device, and removing the release layer covering the adhesive if a release layer is present,
- placing the proximal end of the infusion set pointing against the skin of the user.

15

Preferably, the method comprises the steps of:

- penetrating the skin of the user by the insertion needle thereby positioning the infusion part, and securing the infusion set to the skin of the patient,
- 20 - removing the device and the needle hub leaving the infusion set in position.

In a preferred embodiment the method comprises the following steps:

- removing the removable part of the packaging,
- 25 - fastening an inserter to the needle hub,
- removing the infusion set from the impenetrable part of the packaging by pulling the inserter, and removing the release layer covering the adhesive if a release layer is present,
- placing the proximal end of the infusion set pointing against the skin of the user,
- 30

- 5
- activating the inserter causing the insertion needle to penetrate the skin and position the infusion part,
 - securing the infusion set to the skin of the patient,
 - removing the inserter and the needle hub leaving the infusion set in position.

10 According to another aspect, the invention provides a method for applying an infusion set comprising an infusion part and a needle hub where the needle hub is combined with an insertion needle, which method comprises the following steps:

- 15
- removing the removable part of the packaging,
 - fastening a device to the needle hub,
 - removing the infusion set from the impenetrable part of the packaging and removing the release layer covering the adhesive by pulling the device,
 - placing the proximal end of the infusion set pointing against the skin of the user.

20 Preferably, the method comprises the steps of:

- penetrating the skin of the user by the insertion needle thereby positioning the infusion part, and securing the infusion set to the skin of the patient,
- removing the device and the needle hub leaving the infusion set in position.

25

It is possible to tighten or load the inserter/secondary device both before and after the infusion set has been removed from the impenetrable part of the packaging by pulling the device.

Description of the drawings

Preferred embodiments of the invention will now be described, by way of example only, with reference to the accompanying drawings in which:

Fig. 1a shows a known needle hub.

5 Fig. 1b shows the same known needle hub from a different angle.

Fig. 2 shows a known needle hub integrated with an infusion part.

Fig. 3 shows an embodiment of the invention where a known needle hub integrated with an infusion part is placed in a protecting packing.

10 Fig. 4 shows a second embodiment of the invention where a known needle hub integrated with an infusion part is placed in a protecting packing.

Fig. 5 shows a third embodiment of the invention where a known needle hub integrated with an infusion part is placed in a protecting packing.

Fig. 6 shows a fourth embodiment of the invention where a known needle hub integrated with an infusion part is placed in a protecting packing.

15 Fig. 7 shows an embodiment of the invention where a known needle hub integrated with an infusion part is placed in a protecting packing provided with a feature for removal of the release paper.

Figs. 8a-8f shows in steps how an embodiment of the invention is to be used.

20 Fig. 9 shows an embodiment of the packaging together with an inserter just before attachment of the inserter.

Fig. 10 shows an embodiment of the packaging together with an inserter just after the inserter has been fastened to the needle hub.

25 Fig. 11 shows an embodiment of the packaging provided with a preferred opening mechanism.

Fig. 12 shows an embodiment of the protecting packaging without needle hub seen from above where the packaging is provided with legs and a substantially centered protrusion for receiving a circular center part.

5 Fig. 13 shows a first sides view the embodiment of the packaging shown in figure 12.

Fig. 14 shows a second side view of the embodiment of the packaging shown in figure 12.

Fig. 15 shows an embodiment of the packaging together with an infusion device.

10 Fig. 16 shows a cross sectional view B-B of the embodiment shown in figure 15.

Fig 17 shows an embodiment of the protecting packaging where the retaining means comprises a separate circular center part.

Fig. 18 shows a sectional view of the retaining means of figure 17.

15 Fig. 19 shows a side view of the retaining means of figure 17.

Fig. 20 shows an embodiment of where a known needle hub integrated with an infusion part is removed from a protecting packaging with a feature for removal of a double spiral release paper.

20 Fig. 21a and 21b show two embodiments of the invention where the release paper covering the adhesive layer is formed as a surface covering the adhesive layer having two extending parts and a central opening.

Definition of words

25 "*Distal side*" refers to the side of the device which is turned away from the patient.

"*Proximal side*" refers to the side of the device which is turned towards the patient, and it will generally be used to describe the part of the device having a surface actually touching the patient.

"Integrated" refers e.g. in the phrase "fastened to a part being integrated with the impenetrable part" to that the part being integrated is connected unreleasably to the impenetrable part or e.g. formed of the same piece of material as the impenetrable part e.g. by molding

- 5 "A *hard material*" as e.g. mentioned in claim 6, can resist a certain pressure without being deformed, at least the impenetrable part which is made of a hard material should be able to resist forces experienced within normal handling of the device.

- 10 "A *relatively soft material*" means that it is possible for the insertion needle (3) to penetrate the material in contrast to the hard material.

Description of embodiments

- 15 Fig. 1a shows an embodiment of a needle hub 1 with a rigid insertion needle 3 and means 14 for retaining a device which could be either a handle or an inserter. The means 14 in this embodiment comprise a cylindrical opening which opening can receive a corresponding form mounted on a handle or an inserter when the handle/inserter is pushed toward the needle hub 1. This embodiment of a needle hub is known from US 6.355.021-B1.

- 20 Fig. 1b shows the same needle hub as fig. 1a seen from the side.

- 25 Fig. 2 shows an embodiment of the same needle hub 1 as in fig. 1a and 1b combined with an infusion part 2. The infusion part can be in one piece comprising a soft cannula extending from the proximal side of the infusion part and a connection in the form of a tube 4 extending from the distal side of the infusion set. In the embodiment of fig. 2 the connection is extending parallel to the patient's skin. The infusion part can also be a combination of two pieces, a part holding the cannula and a connector part, where a cannula is extending from the proximal side of the infusion part while the connection is extending from a distal side of the connector part. The infusion part 2 is formed with a center piece 5 on the proximal side. The center piece 5 can be
- 30

extending relatively to the proximal surface of the infusion part 2 or the proximal side of the adhesive 6, as it is shown in fig. 2, but it can also be retracted relatively to these surfaces. If the center piece 5 is retracted it can be formed by a circular groove or recess in the infusion part 2 surrounding the center piece 5.

An adhesive layer 6 preferably covered with a release layer 6a is unreleasably fastened to the proximal side of the infusion part 2. In the embodiment of fig. 2 the cannula is adjoined to the insertion needle although the cannula is not actually shown in the figure.

Fig. 3 shows a combination comprising a needle hub 1 and an infusion part 2 in an embodiment of the inventive packaging 7, 8. The packaging comprises an impenetrable part 7 preferably formed of a relatively hard plastic such as PP, PE HD or PVC. At least the impenetrable part 7 should be able to resist forces experienced within normal handling of the device without being deformed and/or penetrated by the insertion needle 3. The impenetrable part 7 covers the proximal side of the combination 1, 2 and due to the chosen material and also due to the positioning of the needle 3, as the needle 3 of the needle hub 1 is placed in a certain distance from the surface of the packaging, the impenetrable part 7 protects the surroundings from the needle. At least a part of the distal side of the combination 1, 2 is covered by a removable part 8 which is at least partly removed by the user before the device is applied.

25

When placed in the packaging the combination 1, 2 is in contact with a support part 9 which part is fastened to or being a part of the inner surface of the packaging. The support part 9 could be circular or in the form of one or more beams, and/or it could be fastened to either a central part reaching towards the periphery without actually touching the periphery or it could be fastened to the periphery reaching for the center. The support part 9 can also

30

function as a release layer for the adhesive 6 meaning that the support part 9 totally or partly protects the adhesive surface during storage.

5 If the support part 9 functions as a release layer it is important to consider the force needed to overcome the release of the infusion part 2 from the support part 9 as the infusion part 2 in some degree is fastened to the support part 9 by adhesion. In order to regulate the attraction between the infusion part 2 and the support surface 9 and thereby also regulate the force needed to overcome the release of the infusion part 2, a suitable fraction of the
10 adhesive 6 surface can be covered by a release layer which has no attraction to the support surface 9.

The support part 9 assures that the combination 1, 2 is positioned in a stable
15 manner.

In a preferred embodiment the support part 9 has the form of a number of ribs fastened to or integrated with the walls of the impenetrable part 7, preferable the ribs are equally distributed along the inner surface of the impenetrable part 7 in order to offer maximum support for the infusion set.
20 Also in a preferred embodiment the periphery of a spiral release layer 6a protecting the adhesive surface 6 is fastened to the impenetrable part 7 or to a part integrated with the impenetrable part 7. The spiral release layer 6a could be fastened to the impenetrable part 7 by gluing, welding or mechanically.

25 In this embodiment of the packaging the needle/cannula of the combination 1, 2 is placed in a circular center part 7a with walls standing upright from the inner surface of the impenetrable part 7. The center piece 5 is squeezed down into the corresponding circular center part 7a and the friction between
30 the piece 5 and the walls in the center part 7a keeps the combination 1, 2 in place.

In another not shown embodiment means 7a comprises flat springs fastened to the periphery of the impenetrable part 7 and pushing down on parts of the infusion part 2 and/or parts of the needle hub 1. The flat springs can during production be pushed down over parts of the infusion device 2 and fastened to the periphery which will keep the combination 1, 2 in place.

In fig. 3 the removable part 8 is made of a paper material e.g. Integra peel medical grade paper or heat seal coated Tyvek, and the paper material is fastened to the upper edge of the impenetrable part 7. Before applying the device the user pulls of the removable part 8 making the combination accessible.

The connection in form of a tube 4 can be twined around the combination 1, 2 (not shown in the figures) which makes it possible to pull out the tube 4 without the tube getting tangled.

Fig. 4 shows another embodiment of the packaging where the removable part 8 is in the form of a relatively hard lid. Before applying the device the user will have to pull of the removable part 8 making the combination accessible.

Fig. 5 shows an embodiment comprising a handle for manual insertion. The handle is formed by integrating the needle hub 1 with the removable part 8, either by creating the two parts as one or by connecting the two parts in a stable manner.

Fig. 6 shows an embodiment of the invention where the center piece 5 is replaced with a material 10 placed inside the circular center part 7a. In another not shown embodiment the lower part of the impenetrable part 7 is filled with this material 10, which e.g. can be silicone, to a height exceeding the length of the needle, in this embodiment the filling material 10 constitutes

the support part 9. According to this solution the combination 1, 2 is kept in place by the friction between the needle and the filling material 10.

5 Fig. 7 shows an embodiment of the invention where a release layer 6a covering the adhesive 6 is removed during release of the combination 1, 2 from the packaging. The release layer 6a is formed as a spiral band where one end – in this embodiment the end closest to the periphery - is connected to the support part 9, and the rest of the release layer 6a is releasably fastened to the adhesive surface 6.

10

The figs. 8a to 8f illustrate an embodiment of the invention and how this embodiment functions during use.

15 In fig. 8a the combination of needle hub 1 and infusion part 2 is placed inside a packaging according to the invention under sterile conditions, and the impenetrable part 7 protects the surroundings from contact with the insertion needle 3. The removable 8 is loosened from the distal edge formed by the impenetrable part 7 but is not totally removed.

20 In fig. 8b the removable part 8 has been totally removed and the tube 4 which is connected to the infusion part 2 has been pulled out of the packaging.

25 In fig. 8c an inserter 11 with a handle 13 has been fastened to the needle hub 1 by pushing the inserter 11 towards the needle hub 1 through the opening that was revealed when the removable part 8 was removed. The inserter 11 comprises internal tracks corresponding to the means 14 of the needle hub 1, and when the inserter 11 is pushed toward the needle hub 1 in the right angle, the needle hub 1 will be pressed into the tracks of the inserter 11 causing the needle hub 1 and the inserter 11 to be fastened to each other.

30

In fig. 8d the tube 4 of the infusion device has been connected to a medical device 12 which in this embodiment has the form of an insulin pump.

5 In fig. 8e the inserter 11 has been prepared for insertion of the infusion set by pulling up the handle 13. The act of pulling up the handle could also be referred to as "tightening" or "loading" the inserter as an internal spring in the inserter is biased by this action. When preparing the inserter 11 the needle hub 1 and the infusion part 2 is released from the packaging and placed inside the inserter 11.

10

In fig. 8f the infusion set connected to the inserter 11 is lifted out of the packaging and it is now ready for inserting the infusion set. When inserting the infusion set the user places the proximal end of the inserter 11 against the skin and thereafter the user activates the inserter 11 and causes the insertion needle 3 to penetrate the skin of the user. After insertion the inserter 11 is pulled away, and if the needle hub 1 to which the insertion needle 3 is fastened, is adequately secured to the inserter, the insertion needle 3 will be removed together with the inserter leaving only the infusion part 2 on the users skin.

20

Fig. 9 shows an embodiment of the packaging 7, 8 together with an inserter 11 just before the inserter 11 is fastened to the needle hub 1. In this embodiment the retaining means 7a squeezes very firmly around corresponding means - the central piece - 5. In order to loosen the strong hold of the central piece 5 the internal form of the packaging is constructed in such a way that the pressing the inserter 11 down toward the needle hub 1 forces the sides of the impenetrable part 7 of packaging outwards.

25

Fig. 10 shows the appearance of the impenetrable part 7 of the packaging after the inserter 11 has been pushed down over the needle hub 1. The diameter of the upright walls constituting the retaining means 7a has been

30

extended and a result of this is that the force needed to pull the center piece 5 out of the retaining means 7a has been reduced.

5 Fig. 11 shows an embodiment of the packaging with means for easy-opening. The impenetrable part 7 is provided with a top flange and the removable part 8 which is preferably made in paper, has been welded to the whole surface of the flange. A line of fracture 15 isolates a corner or a piece of the top flange of the impenetrable part 7 and when the user opens the packaging the corner/piece is broken off the top flange and the removable part which is not provided with a fractured line will be easily removed by pulling the in the broken off piece which is still welded to the piece of the removable part 8 covering the piece.

15 Fig. 12-14 shows a further embodiment of the packaging from the outside at three different angles. The impenetrable part 7 has an upper end which is provided with the removable part 8 and a lower end positioned opposite the upper end. Fig. 12 shows the packaging from above, meaning from the upper end of the impenetrable part 7 of the packaging, where fig. 13 and 14 shows two different side views of the packaging. This embodiment of the packaging according to fig. 12-14 shows the impenetrable part 7 being shaped with three legs 7d protruding from the lower surface of the impenetrable part (7) and a substantially centered shaped protrusion 7c inside which a separate center part 7b is positioned.

25 Fig. 15 shows an embodiment of the packaging where the needle/cannula of the combination 1, 2 is placed in the center part 7b. In this embodiment the center part 7b is circular and formed as a separate part. The center part 7b is placed upright from the inner surface of the impenetrable part 7 in a correspondingly shaped protrusion 7c in the impenetrable part 7 of the packaging. The separate center part 7b is lengthwise provided with a through-going slit 14, which makes the center part 7b elastic, i.e. it is possible

30

to vary the dimension of the center part 7b. The center part 7b is placed in the correspondingly shaped protrusion 7c engaging with the center piece 5 of the impenetrable part 7. As the center piece 5 engages with the corresponding circular center part 7b, the center part 7b is expanded and the center part 7b is fixed in the protrusion 7c. The friction between the center piece 5 and the separate circular center piece 7b placed in the correspondingly shaped protrusion 7c in the impenetrable part 7 keeps the combination 1, 2 in place. Further, the friction occurring between the center part 7b and the protrusion 7c keeps the center part 7b within the protrusion 7b of the packaging, this friction being larger than the friction between the center piece 7b and the combination 1, 2.

In preparing the infusion set for insertion the removable part 8 is removed from the impenetrable part 7 and the combined needle hub 1 and infusion part 2 is released from the packaging either manually or by an inserter 11. In order to loosen the strong hold of the center piece 5, the form of the separate center part 7b is constructed in such a way that the pressing of the inserter 11 down toward the needle hub 1 forces the center part 7b to expand outwards towards the protrusion 7c in the packaging, which is possible due to the slit which makes to center part 7b elastic.

Fig. 17-19 shows a circular embodiment of the center part 7b with a lengthwise through-going slit 14. The circular center part 7b is in this embodiment provided with a circular part 16 having a smaller diameter than the diameter of the circular center part 7b via a shoulder part 15 which secures and keeps the center piece 5 in place.

Fig. 20 shows an embodiment of the invention where a release layer 6a covering the adhesive 6 is removed during release of the combination 1, 2 from the packaging. The release layer 6a is in this embodiment divided into two sections where each section forms a strip such as a spiral band, thereby

forming a double spiral release layer 6a. The peripheral end 17 of each strip of the release layer 6a closest to the periphery, only one is shown in the figure, are connected to the impenetrable part 7 or to a part integrated with the impenetrable part 7, and the rest of the release layer 6a is releasably fastened to the adhesive surface 6. As the above mentioned single spiral release layer 6a, this double spiral release layer 6a could also be connected or fastened to the impenetrable part by gluing, welding or mechanically. In this embodiment, when pressing the inserter 11, not shown in fig. 20, down for releasing of the combination 1, 2 from the packaging, the peripheral end 17 of each strip of the release layer 6a in the form of a tab are pressed down towards the impenetrable part 7 of the interior packaging and fastened with glue, said glue being placed at points corresponding to the tabs 17 within the interior of the packaging on the impenetrable part 7. When releasing the needle hub 1 and infusion part 2 from the packaging the release layer is then automatically peeled of the adhesive layer.

Fig. 21a shows one embodiment of the release layer 6a covering the adhesive layer, where the release layer 6a is in a single piece and has two extending peripheral ends 17 in the form of protruding tabs intended for fastening to the impenetrable part 7 or to a part integrated with the impenetrable part 7.

Fig. 21 b shows another embodiment of the release layer 6a where the release layer is divided into two sections 6b and 6c, each section forming a strip such as a spiral band, thereby forming a double spiral release layer 6a. In this embodiment each extending peripheral end 17 of each strip of the release layer 6a are also in the form of protruding tabs 17 intended for fastening to the impenetrable part 7 or to a part integrated with the impenetrable part 7. This embodiment is a more suitable form of the release layer than the form shown in fig. 21a as the strips defines a more precise length for the releasing of the release layer. Furthermore, by a single pull the

release layer can be removed from the adhesive layer in two narrow strips and only little force is needed to remove it.

THE CLAIMS DEFINING THE INVENTION ARE AS FOLLOWS:-

- 5 1. Packaging for an infusion set comprising an infusion part and a needle hub where the needle hub is combined with an insertion needle, which packaging comprises a support part for holding the infusion part and the needle hub, an impenetrable part protecting the surroundings from the insertion needle and a removable part which is to be removed by the user before applying the infusion part wherein the inner part of the impenetrable part comprises retaining means for releasably retaining at least a part of the infusion set.
- 10
2. Packaging according to claim 1, wherein the retaining means are an integrated part of the impenetrable part.
- 15 3. Packaging according to claim 1, wherein the retaining means is a separate part.
4. Packaging according to claim 3, wherein the separate part is maintained in the impenetrable part when the infusion set is released from the packaging.
- 20 5. Packaging according to any one of claims 1 to 4, wherein the proximal side of the infusion set is provided with an adhesive.
- 25 6. Packaging according to claim 5, wherein the adhesive is covered with a release layer and the release layer covering the adhesive is partly fastened to the impenetrable part or fastened to a part being connected to the impenetrable part.
- 30 7. Packaging according to claim 6, wherein the release layer has the form of a band and that one end of the band is fastened to the impenetrable part or fastened to a part being connected to the impenetrable part.

8. Packaging according to claim 6, wherein the release layer has the form of at least two bands where one end of each band is fastened to the impenetrable part or fastened to a part being connected to the impenetrable part.
- 5
9. Packaging according to any one of claims 1 to 8, wherein the impenetrable part is made of a hard material.
10. Packaging according to claim 9, wherein the impenetrable part is made of polypropylene (PP), polyethylene (PE HD) or PVC.
- 10
11. Packaging according to any one of claims 1 to 10, wherein the needle hub is provided with means which means can retain an inserter when the inserter is pushed towards the needle hub from the distal side.
- 15
12. Packaging according to any one of claims 1 to 11, wherein the infusion set is releasably retained by the retaining means formed as an integrated part of the impenetrable part of the packaging.
- 20
13. Packaging according to claim 12, wherein the infusion part is provided with corresponding means which are releasably connected to the retaining means.
- 25
14. Packaging according to claim 12, wherein the retaining means are formed as walls standing from the impenetrable part in an angle between -45° and 45° where 0° is orthogonal to the proximal surface of the impenetrable part.
- 30
15. Packaging according to claim 14, wherein the corresponding means are formed as a cylinder or a truncated cone integrated with the infusion part.

16. Packaging according to claim 12, wherein the retaining means are formed of a relatively soft material which material can be penetrated by the insertion needle and which soft material is connected unreleasably to the impenetrable part of the packaging.

5

17. A method for applying an infusion set comprising an infusion part and a needle hub where the needle hub is combined with an insertion needle, which method comprises the following steps:

- removing the removable part of the packaging,
- 10 - fastening a device to the needle hub,
- removing the infusion set from the impenetrable part of the packaging by pulling the device, and removing the release layer covering the adhesive if a release layer is present,
- 15 - placing the proximal end of the infusion set pointing against the skin of the user.

18. A method for applying an infusion set comprising an infusion part and a needle hub where the needle hub is combined with an insertion needle, which method comprises the following steps:

- 20 - removing the removable part of the packaging,
- fastening a device to the needle hub,
- removing the infusion set from the impenetrable part of the packaging and removing the release layer covering the adhesive by pulling the device,
- 25 - placing the proximal end of the infusion set pointing against the skin of the user.

19. Packaging for an infusion set substantially as herein described with reference to any one of the embodiments of the invention illustrated in the
30 accompanying drawings and/or examples.

20. A method for applying an infusion set, the method being substantially as herein described with reference to any one of the embodiments of the invention illustrated in the accompanying drawings and/or examples.

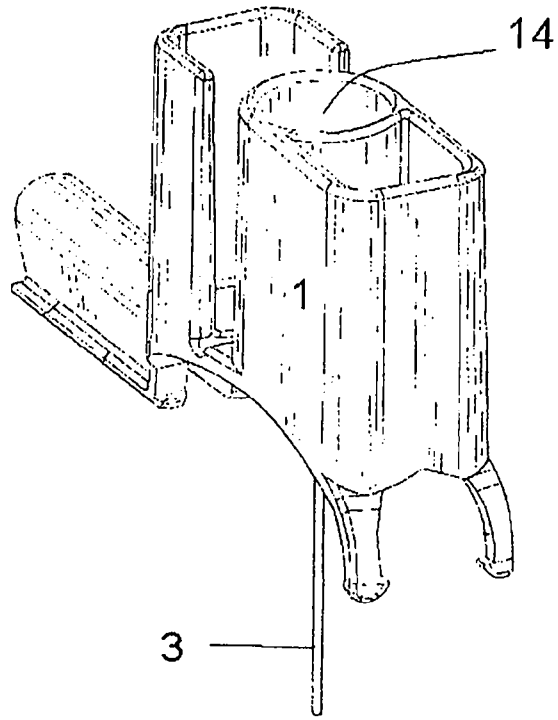

Fig. 1a
PRIOR ART

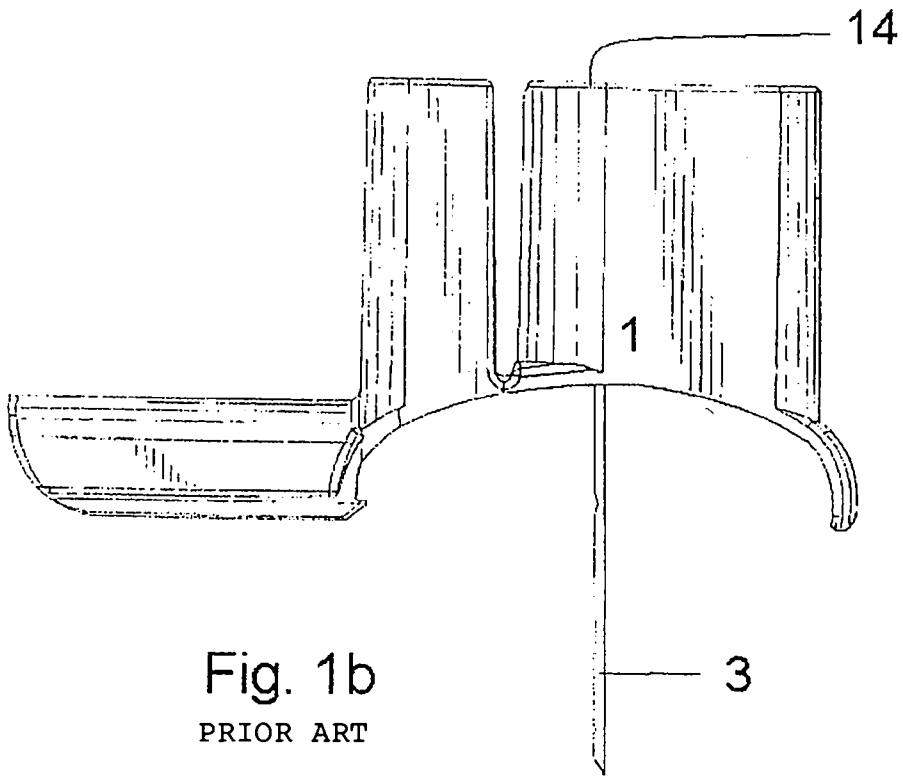

Fig. 1b
PRIOR ART

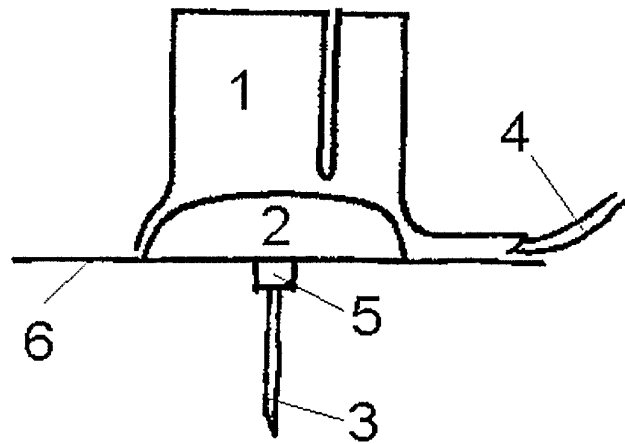

Fig. 2

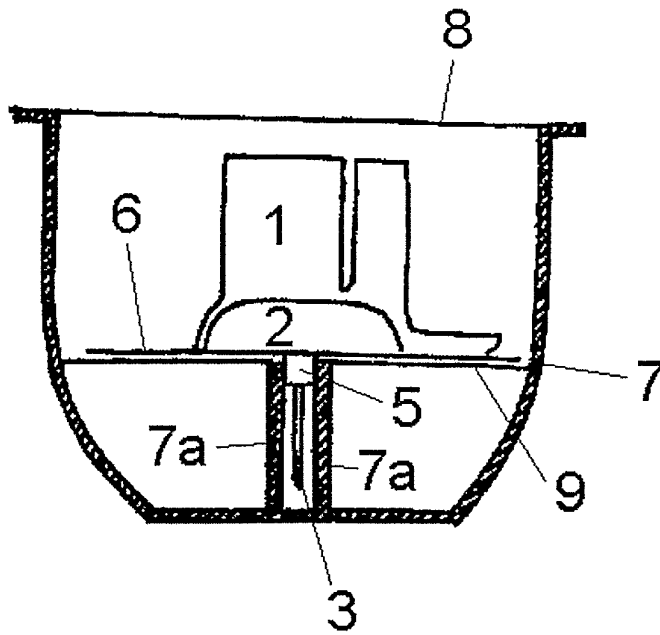

Fig. 3

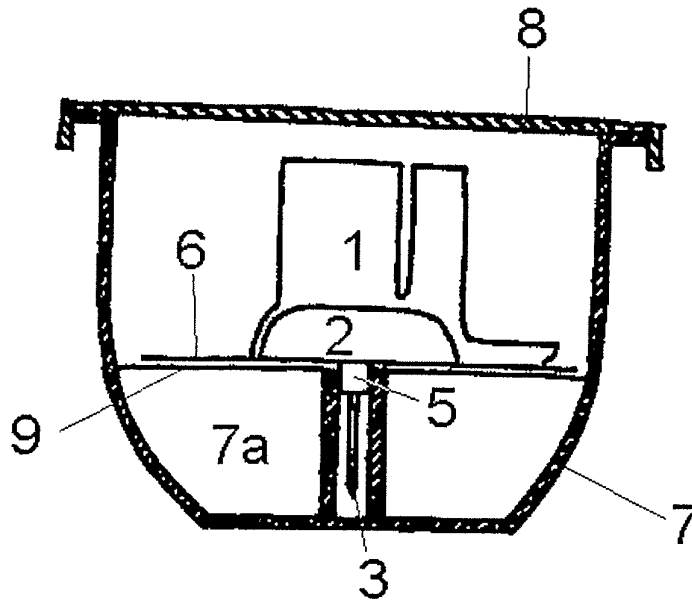

Fig. 4

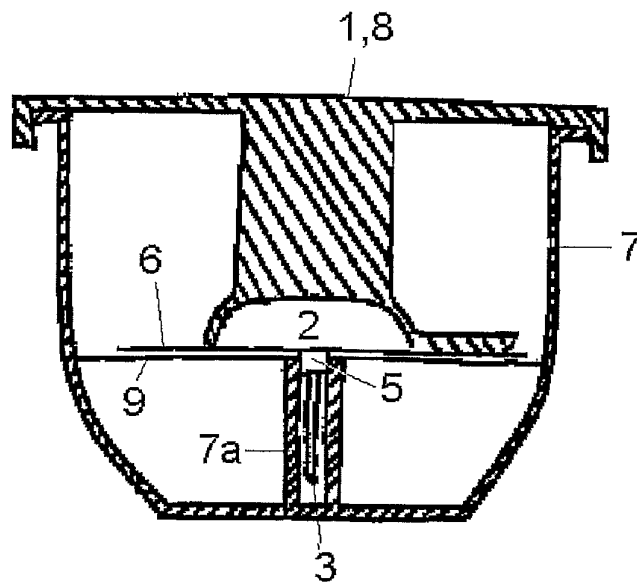

Fig. 5

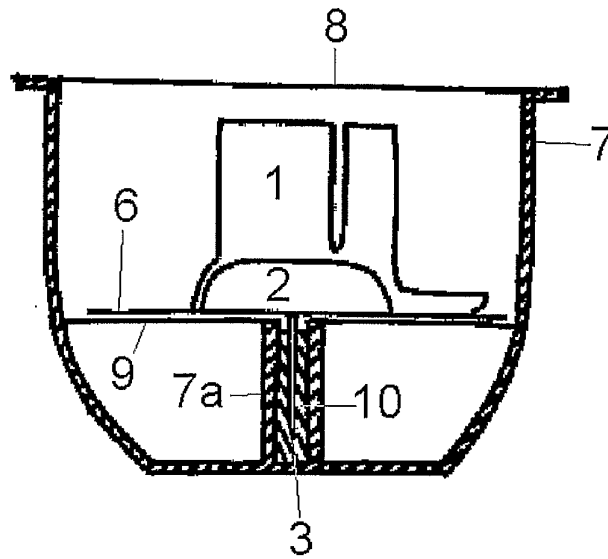

Fig. 6

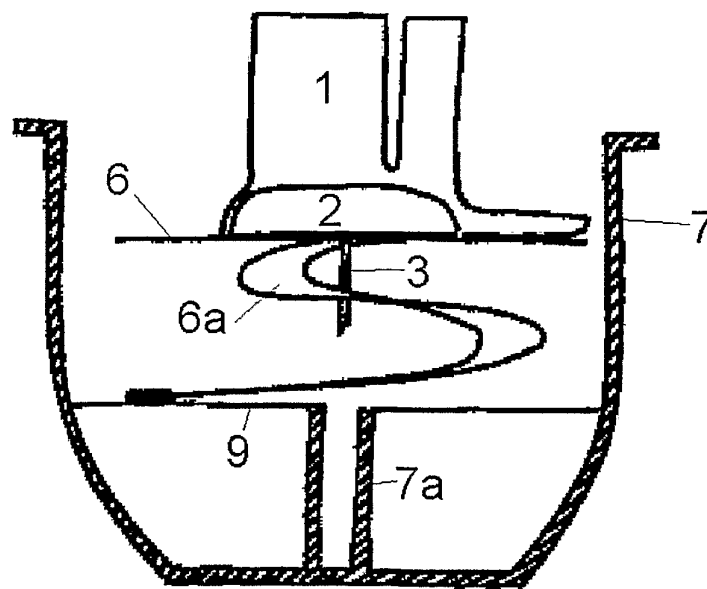

Fig. 7

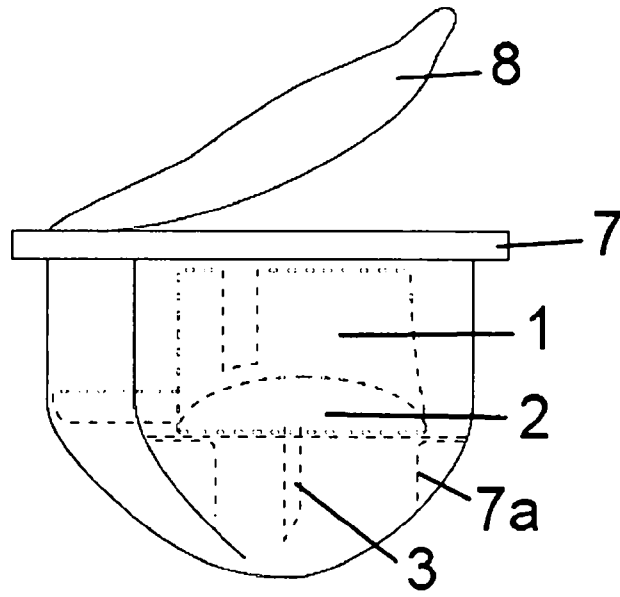

Fig. 8a

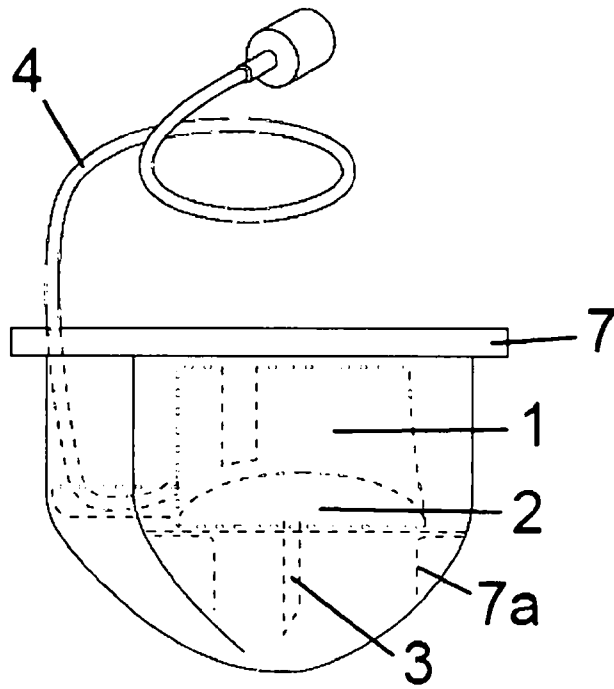

Fig. 8b

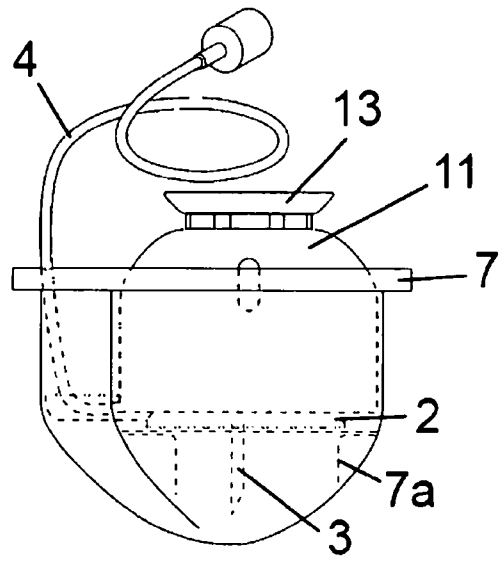

Fig. 8c

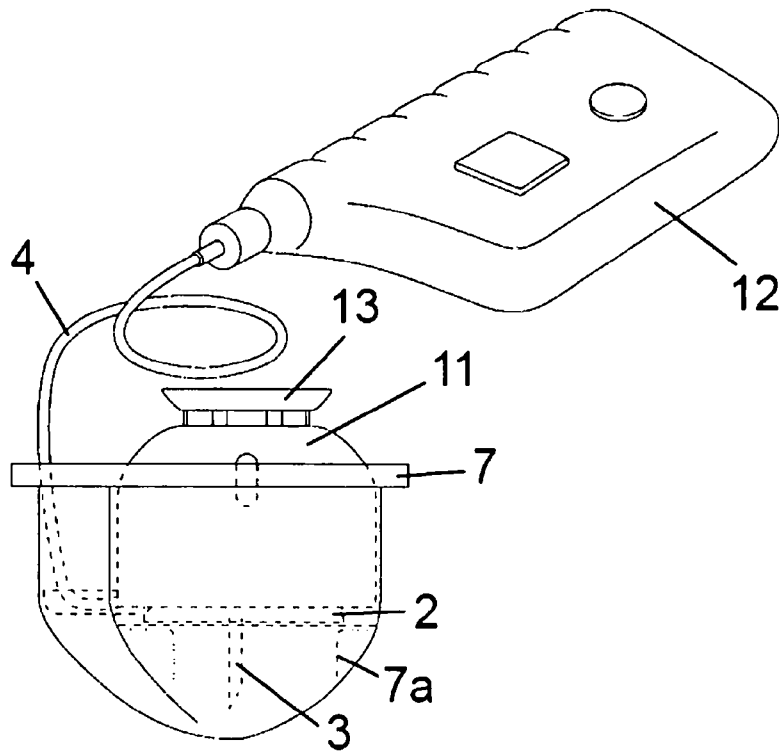

Fig. 8d

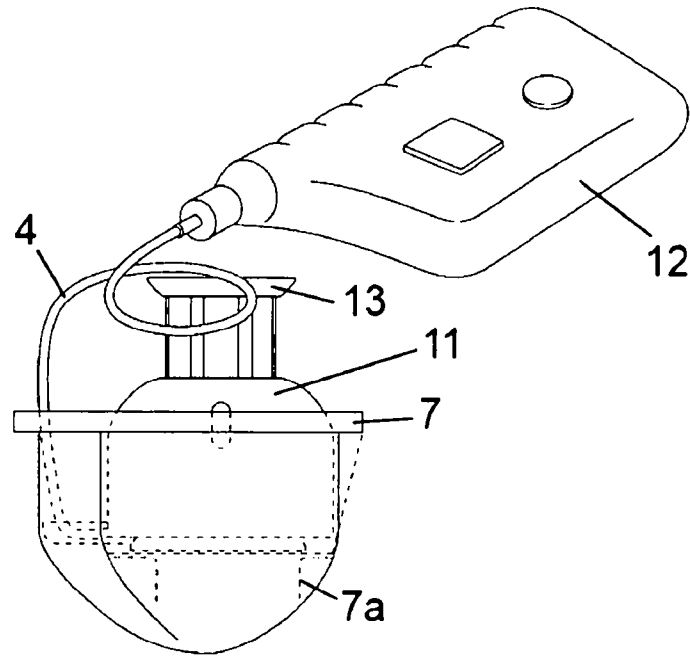

Fig. 8e

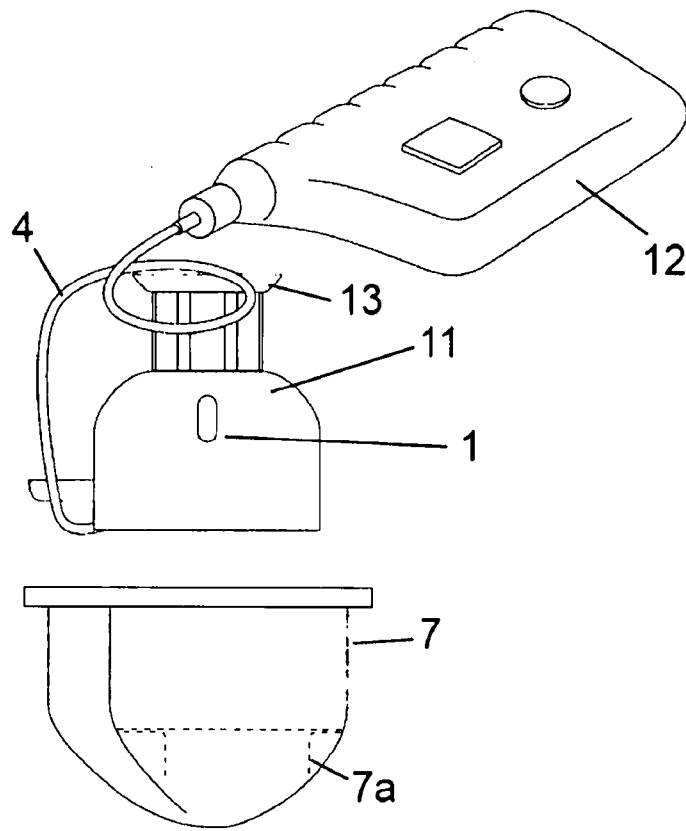

Fig. 8f

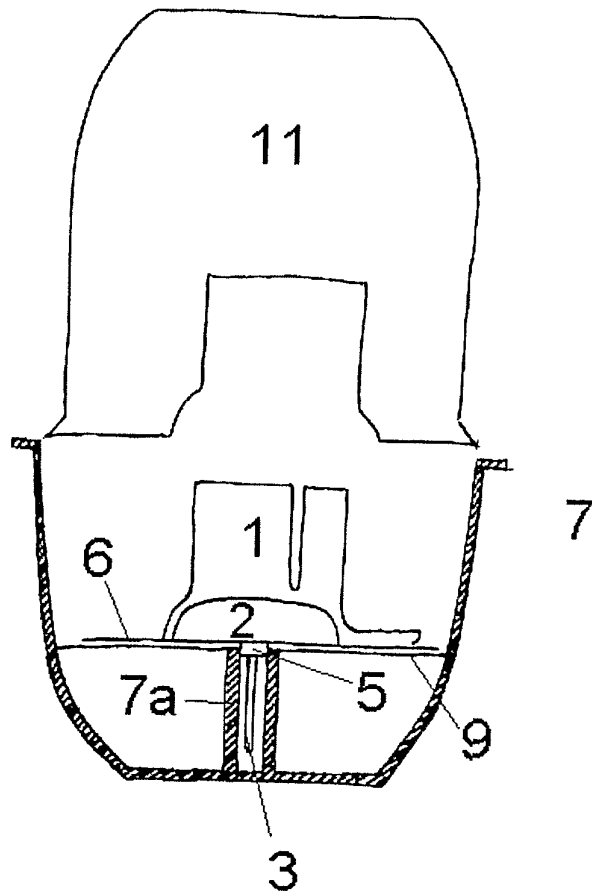

Fig. 9

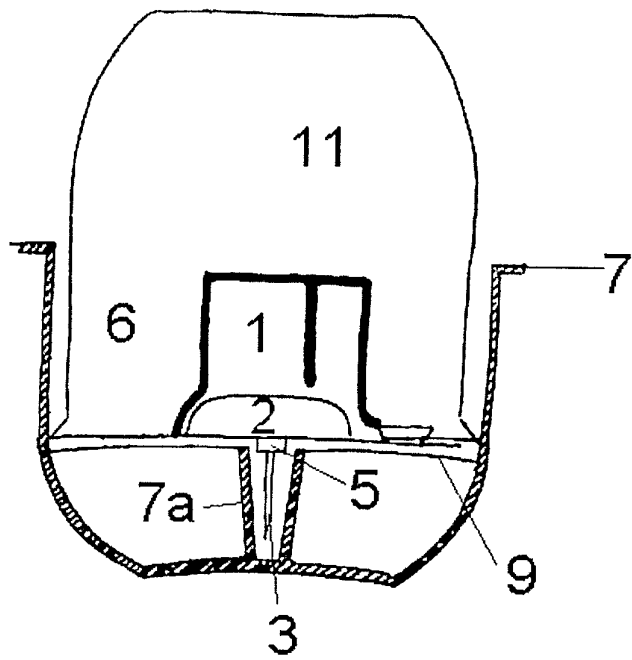

Fig. 10

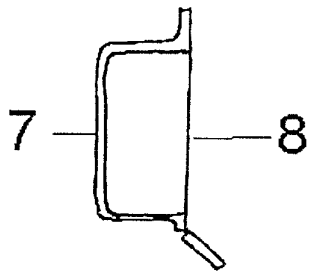
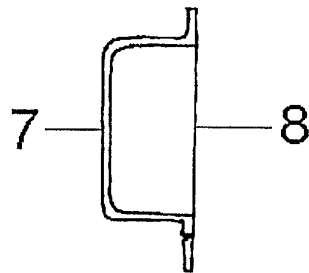
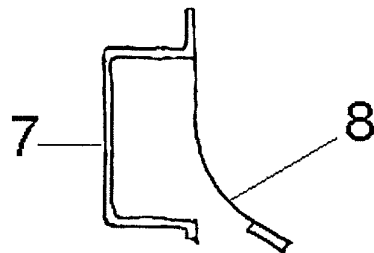

Fig. 11



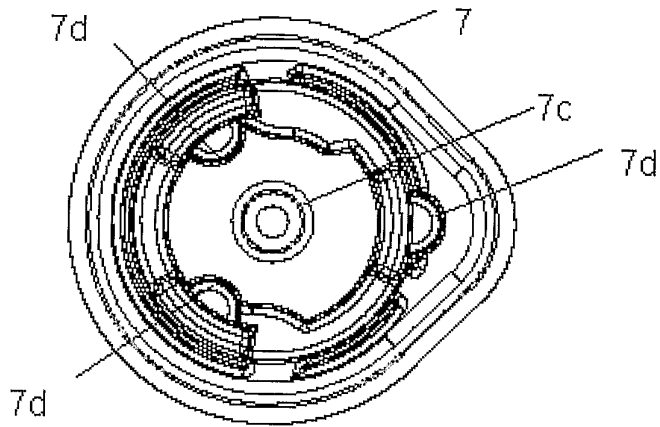

Figure 12

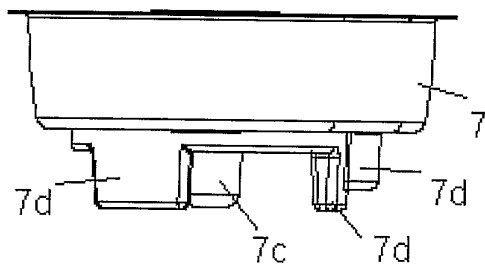

Figure 13

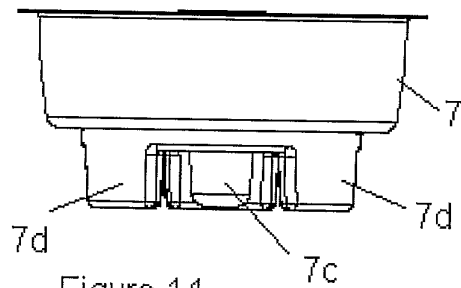

Figure 14

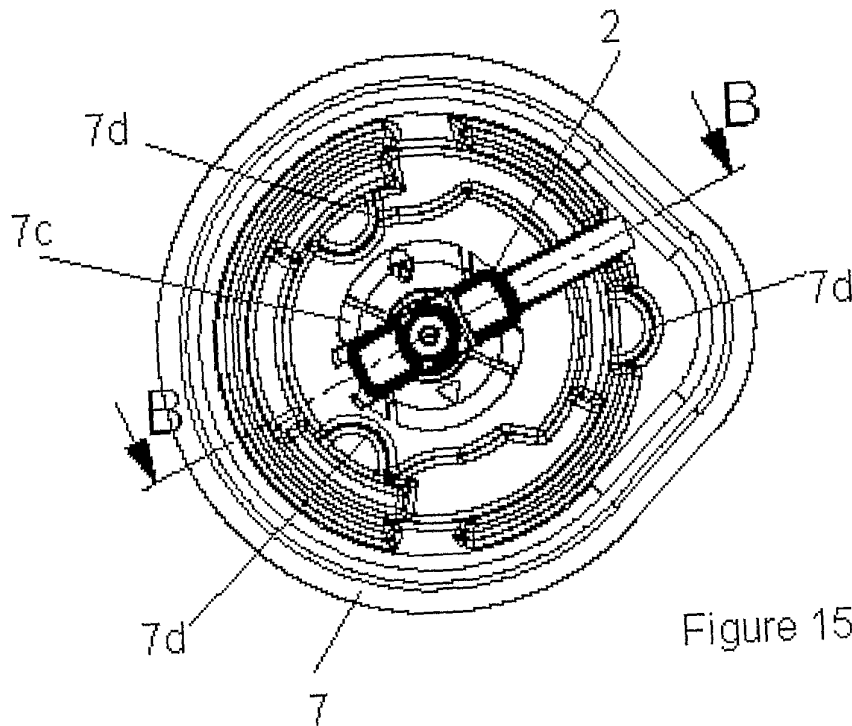

Figure 15

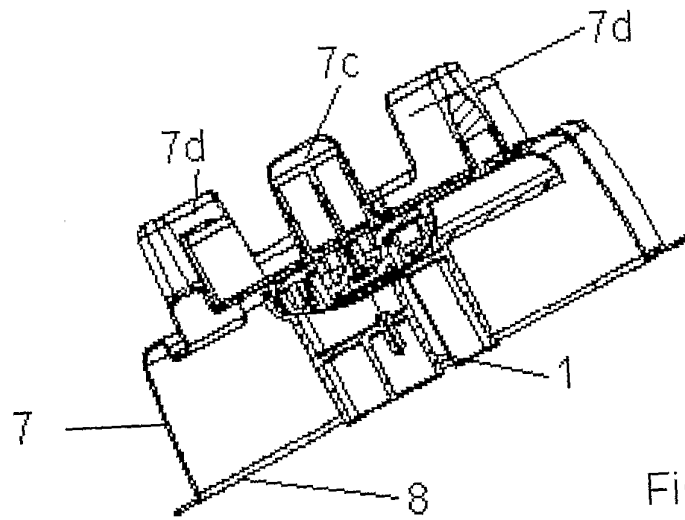

Figure 16

SECTION B-B

Figure 17

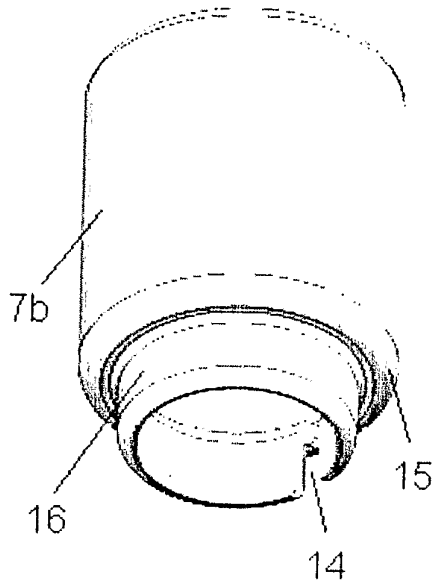

Figure 18

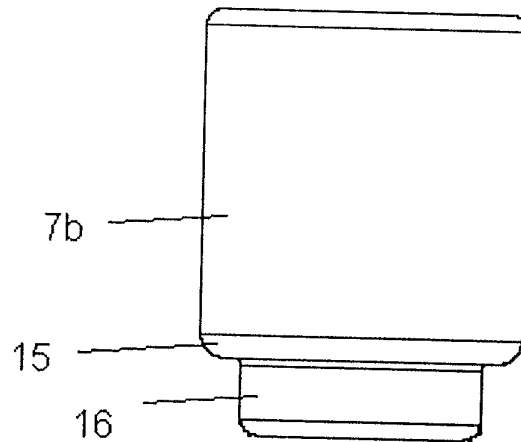
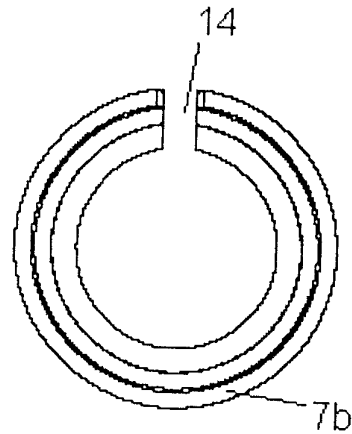

Figure 19

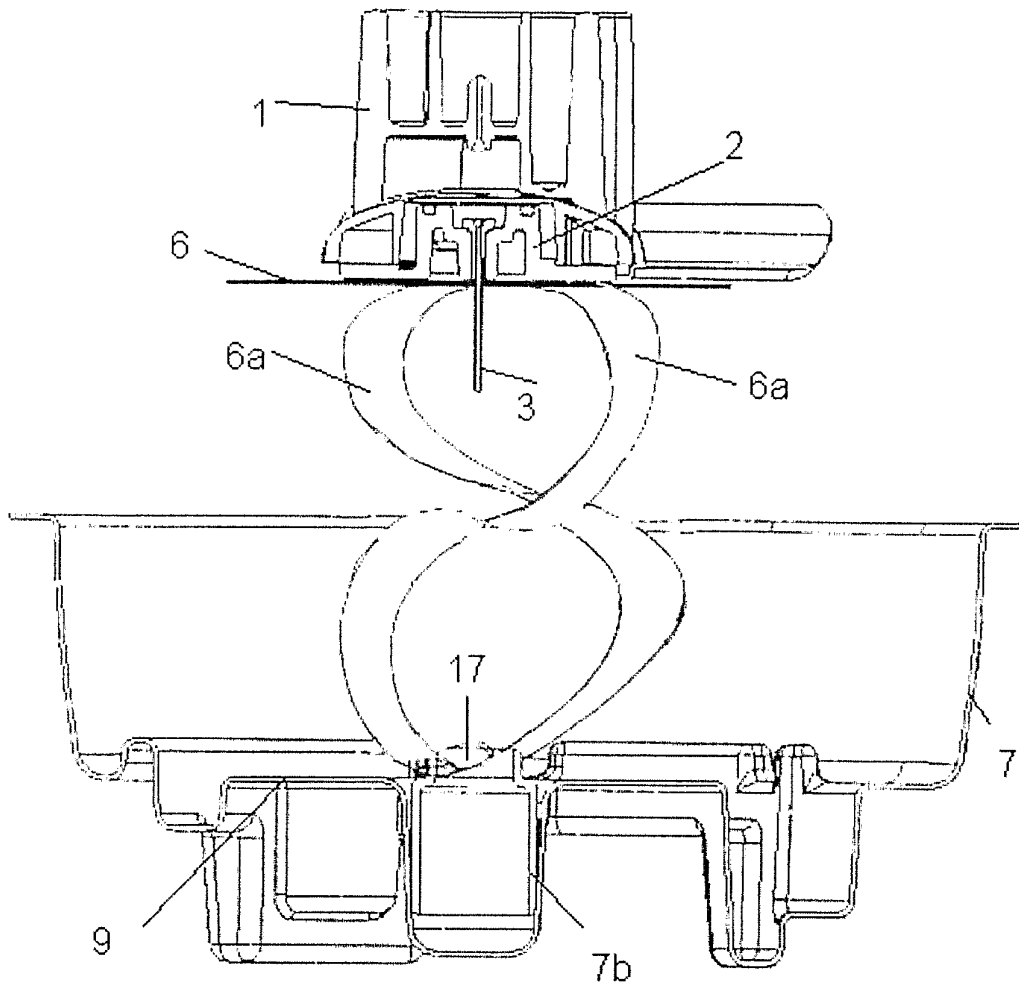

Figure 20

15 / 15

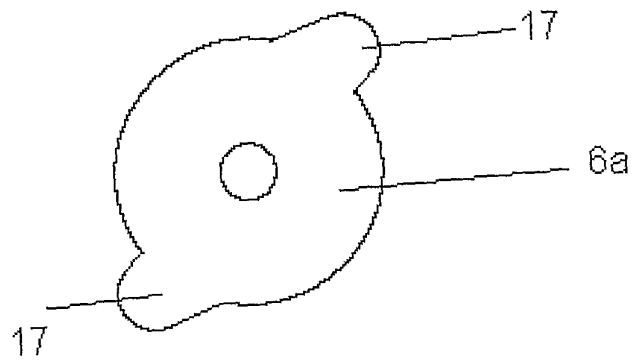

Figure 21 a

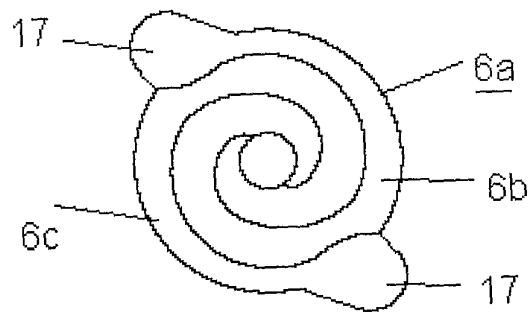

Figure 21 b