

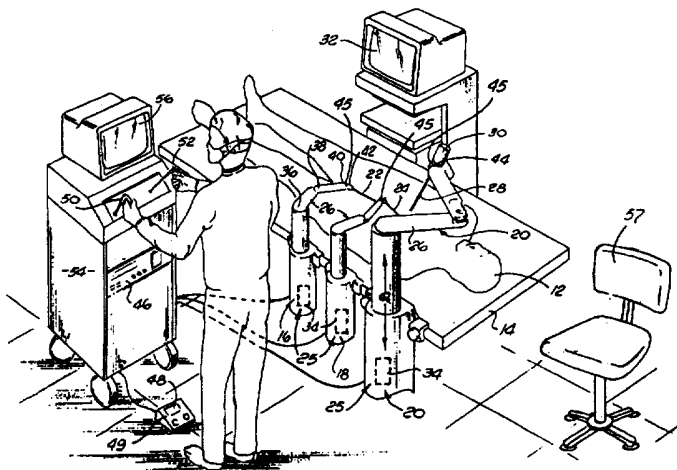

INTERNATIONAL APPLICATION PUBLISHED UNDER THE PATENT COOPERATION TREATY (PCT)

| | | |
|--|------------------|---|
| <p>(51) International Patent Classification ⁶ : A61B 17/00</p> | <p>A1</p> | <p>(11) International Publication Number: WO 97/29690</p> <p>(43) International Publication Date: 21 August 1997 (21.08.97)</p> |
| <p>(21) International Application Number: PCT/US97/02628</p> <p>(22) International Filing Date: 19 February 1997 (19.02.97)</p> <p>(30) Priority Data: 08/603,543 20 February 1996 (20.02.96) US 08/755,063 22 October 1996 (22.10.96) US</p> <p>(71) Applicant: COMPUTER MOTION, INC. [US/US]; 130 B Cremona Drive, Goleta, CA 93117 (US).</p> <p>(72) Inventors: WANG, Yulun; 370 Vereda Leyena, Goleta, CA 93117 (US). UECKER, Darrin, R.; 1430 De La Vina #A, Santa Barbara, CA 93101 (US). LABY, Keith, Phillip; 220 Santa Rosa, Santa Barbara, CA 93109 (US). WILSON, Jeff; 1300 Portesuello, Santa Barbara, CA 93105 (US). JORDAN, Steve; 2431 Calle Galicia, Santa Barbara, CA 93109 (US). WRIGHT, James; 319 Santa Cruz Boulevard, Santa Barbara, CA 93109 (US). GHODOUSSI, Modjtaba; 36 Broadmoor Plaza #2, Santa Barbara, CA 93105 (US).</p> <p>(74) Agents: YORKS, Ben, J. et al.; Blakely, Sokoloff, Taylor & Zafman, 7th floor, 12400 Wilshire Boulevard, Los Angeles, CA 90025-1026 (US).</p> | | <p>(81) Designated States: AL, AM, AT, AT (Utility model), AU, AZ, BA, BB, BG, BR, BY, CA, CH, CN, CU, CZ, CZ (Utility model), DE, DE (Utility model), DK, DK (Utility model), EE, EE (Utility model), ES, FI, FI (Utility model), GB, GE, HU, IL, IS, JP, KE, KG, KP, KR, KZ, LC, LK, LR, LS, LT, LU, LV, MD, MG, MK, MN, MW, MX, NO, NZ, PL, PT, RO, RU, SD, SE, SG, SI, SK, SK (Utility model), TJ, TM, TR, TT, UA, UG, UZ, VN, YU, ARIPO patent (KE, LS, MW, SD, SZ, UG), Eurasian patent (AM, AZ, BY, KG, KZ, MD, RU, TJ, TM), European patent (AT, BE, CH, DE, DK, ES, FI, FR, GB, GR, IE, IT, LU, MC, NL, PT, SE), OAPI patent (BF, BJ, CF, CG, CI, CM, GA, GN, ML, MR, NE, SN, TD, TG).</p> <p>Published <i>With international search report. Before the expiration of the time limit for amending the claims and to be republished in the event of the receipt of amendments.</i></p> |

(54) Title: A METHOD AND APPARATUS FOR PERFORMING MINIMALLY INVASIVE CARDIAC PROCEDURES



(57) Abstract

This invention is a system (10) for performing minimally invasive cardiac procedures. The system includes a pair of surgical instruments that are coupled to a pair of robot arms (16, 18). The instruments (22, 24) have end effectors that can be manipulated to hold and suture tissue. The robotistic arms are coupled to a pair of master handles (50, 52) by a controller. The handles can be moved by the surgeon to produce a corresponding movement of the end effectors. The movement of the handles is scaled so that the end effectors have a corresponding movement that is different, typically smaller, than the movement performed by the hands of the surgeon. The scale factor is adjustable so that the surgeon can control the resolution of the end effector movement. The movement of the end effector can be controlled by an input button, so that the end effector only moves when the button is depressed by the surgeon. The input button allows the surgeon to adjust the position of the handles without moving the end effector, so that the handles can be moved to a more comfortable position.

FOR THE PURPOSES OF INFORMATION ONLY

Codes used to identify States party to the PCT on the front pages of pamphlets publishing international applications under the PCT.

| | | | | | |
|----|--------------------------|----|--|----|--------------------------|
| AM | Armenia | GB | United Kingdom | MW | Malawi |
| AT | Austria | GE | Georgia | MX | Mexico |
| AU | Australia | GN | Guinea | NE | Niger |
| BB | Barbados | GR | Greece | NL | Netherlands |
| BE | Belgium | HU | Hungary | NO | Norway |
| BF | Burkina Faso | IE | Ireland | NZ | New Zealand |
| BG | Bulgaria | IT | Italy | PL | Poland |
| BJ | Benin | JP | Japan | PT | Portugal |
| BR | Brazil | KE | Kenya | RO | Romania |
| BY | Belarus | KG | Kyrgystan | RU | Russian Federation |
| CA | Canada | KP | Democratic People's Republic of Korea | SD | Sudan |
| CF | Central African Republic | KR | Republic of Korea | SE | Sweden |
| CG | Congo | KZ | Kazakhstan | SG | Singapore |
| CH | Switzerland | LI | Liechtenstein | SI | Slovenia |
| CI | Côte d'Ivoire | LU | Luxembourg | SK | Slovakia |
| CM | Cameroon | LV | Latvia | SN | Senegal |
| CN | China | LR | Liberia | SZ | Swaziland |
| CS | Czechoslovakia | LT | Lithuania | TD | Chad |
| CZ | Czech Republic | LU | Luxembourg | TG | Togo |
| DE | Germany | LV | Latvia | TJ | Tajikistan |
| DK | Denmark | MC | Monaco | TT | Trinidad and Tobago |
| EE | Estonia | MD | Republic of Moldova | UA | Ukraine |
| ES | Spain | MG | Madagascar | UG | Uganda |
| FI | Finland | ML | Mali | US | United States of America |
| FR | France | MN | Mongolia | UZ | Uzbekistan |
| GA | Gabon | MR | Mauritania | VN | Viet Nam |

A METHOD AND APPARATUS FOR PERFORMING MINIMALLY INVASIVE CARDIAC PROCEDURES

BACKGROUND OF THE INVENTION

Relation To Previously Filed Applications:

The present application is a continuation-in-part Application of U.S. Patent Application entitled "**A Method and Apparatus For Performing Minimally Invasive Cardiac Procedures**", which received serial number 08/603,543 and which was filed on February 20, 1996, and which is presently pending and is incorporated herein by reference.

1. FIELD OF THE INVENTION

The present invention relates to a system and method for performing minimally invasive cardiac procedures. More particularly, the present invention relates to a robotic system and surgical instruments that may be removably attached thereto, wherein said system aids in performing minimally invasive surgical procedures.

2. DESCRIPTION OF RELATED ART

Blockage of a coronary artery may deprive the heart of the blood and oxygen required to sustain life. The blockage may be removed with medication or by an angioplasty. For severe blockage a coronary artery bypass graft (CABG) is performed to bypass the blocked area of the artery. CABG procedures are typically performed by splitting the sternum and pulling open the chest cavity to provide access to the heart. An incision is made in the artery adjacent to the blocked area. The internal mammary artery (IMA) is then severed and attached to the artery at the point of incision.

The IMA bypasses the blocked area of the artery to again provide a full flow of blood to the heart. Splitting the sternum and opening the chest cavity, commonly referred to as 'open surgery', can create a tremendous trauma on the patient. Additionally, the cracked sternum prolongs the recovery period of the patient.

There have been attempts to perform CABG procedures without opening the chest cavity. Minimally invasive procedures are conducted by inserting surgical instruments and an endoscope through small incision in the skin of the patient. Manipulating such instruments can be awkward, particularly when suturing a graft to a artery. It has been found that a high level of dexterity is required to accurately control the instruments. Additionally, human hands typically have at least a minimal amount of tremor. The tremor further increases the difficulty of performing minimally invasive cardiac procedures.

To perform MIS, the surgeon uses special instruments. These instruments allow the surgeon to maneuver inside the patient. One type of instrument that is used in minimally invasive surgery is forceps, an instrument having a tip specifically configured to grasp objects, such as needles. Because forceps and other instruments designed for minimally invasive surgery are generally long and rigid, they fail to provide a surgeon the dexterity and precision necessary to effectively carry out many procedures in a minimally invasive fashion. For example, conventional MIS forceps are not well suited for manipulating a needle during a minimally invasive procedure, such as during endoscopy. Therefore, many MIS procedures that might be performed, have, as of yet, not been accomplished.

In essence, during open surgeries, the tips of the various instruments may be positioned with six degrees of freedom. However, by inserting an instrument through

a small aperture, such as one made in a patient to effectuate a minimally invasive procedure, two degrees of freedom are lost. It is this loss of freedom of movement within the surgical site that has substantially limited the types of MIS procedures that are performed.

Dexterity is lacking in MIS because the instruments that are used fail to provide the additionally degrees of freedom that are lost when the instrument is inserted into a patient. One problem associated with this lack of dexterity is the inability to suture when the instruments are in certain positions. As a result, surgeries that require a great deal of suturing within the surgical site are almost impossible to perform because the surgical instruments to enable much of this work are not available.

Another problem associated with MIS is the lack of precision within the surgical site. For procedures such as the MICABG (Minimally Invasive Coronary Artery Bypass Graft), extremely small sutures must be emplaced in various locations proximate the heart. As such, precise motion of the tool at the tip of a surgical instrument is necessary. Currently, with hand positioned instruments, the precision necessary for such suturing is lacking.

As such, what is needed in the art is a tool and class of surgical instruments that may be articulated within the patient such that a surgeon has additional degrees of freedom available to more dexterously and precisely position the tool at the tip of the instrument, as is needed.

Additionally, what is needed in the art is a method and mechanism that provides simple instrument and tool changing capabilities so that various tools may be easily and readily replaced to enable faster procedures to thus minimize operating room costs to the patient and

to lessen the amount of time a patient is under anesthesia.

It is to the solution of the aforementioned problems to which the present invention is directed.

SUMMARY OF THE INVENTION

The present invention is a system for performing minimally invasive cardiac procedures. The system includes a pair or more of surgical instruments that are coupled to a pair of robotic arms. The system may include only a single surgical instrument and a single robotic arm as well and as is hereinbelow disclosed. The instruments have end effectors that can be manipulated to sever, hold, cauterize and suture tissue. The robotic arms are coupled to a pair of master handles by a controller. The handles can be moved by the surgeon to produce a corresponding movement of the end effectors. The movement of the handles is scaled so that the end effectors have a corresponding movement that is different, typically smaller, than the movement performed by the hands of the surgeon. This helps in removing any tremor the surgeon might have in their hands. The scale factor is adjustable so that the surgeon can control the resolution of the end effector movement. The movement of the end effector can be controlled by an input button, so that the end effector only moves when the button is depressed or toggled by the surgeon. The input button allows the surgeon to adjust the position of the handles without moving the end effector, so that the handles can be moved to a more comfortable position. The system may also have a robotically controlled endoscope which allows the surgeon to remotely view the surgical site. A cardiac procedure can be performed by making small incisions in the patient's skin and inserting the instruments and endoscope into the patient. The surgeon manipulates the

handles and moves the end effectors to perform a cardiac procedure such as a coronary artery bypass graft or heart valve surgery.

The present invention is additionally directed to a surgical instrument and method of control thereof which permits the surgeon to articulate the tip of the instrument, while retaining the function of the tool at the tip of the instrument. As such, the instrument tip may be articulated with two degrees of freedom, all the while the tool disposed at the tip may be used.

The robotic system generally comprises:

- a robotic arm;
- a coupler that attached to the arm;
- a surgical instrument that is held by the coupler;

- a controller; and

wherein movement at the controller produces a proportional movement of the robotic arm and surgical instrument.

The present invention may include a surgical instrument that has an elongated rod. The elongated rod has a longitudinal axis and generally serves as the arm of the endoscopic instrument. An articulate portion is mounted to and extends beyond the elongated rod. Alternatively, the articulate portion may be integrally formed with the elongated rod. The articulate portion has a proximal portion, a pivot linkage and a distal portion. The proximal portion may include a pair of fingers. The fingers may be orthogonal to each other and oriented radially to the longitudinal axis of the elongated rod. For use in surgical procedures, it is generally preferable that the instrument and the majority of the components therein are formed of stainless steel, plastic, or some other easily sterilizable material. Each of the fingers may have at least one aperture formed therein to allow the passage

of a pin which aids in the attachment of the pivot linkage to the proximal portion of the articulate portion and which allows the pivot linkage to be pivotally mounted to the proximal portion. The articulate portion provides articulation at the tip of an instrument that includes the articulate portion. More particularly, this provides additional degrees of freedom for the tool at the tip of an instrument that includes an articulate portion.

An instrument such as that disclosed hereinbelow, when used in conjunction with the present surgical system, provides the surgeon additional dexterity, precision, and flexibility not yet achieved in minimally invasive surgical procedures. As such, operation times may be shortened and patient trauma greatly reduced.

To provide increased precision in positioning the articulated tip as disclosed hereinbelow, there is provided two additional degrees of freedom to the master controller. Each of the two additional degrees of freedom are mapped to each of the degrees of freedom at the instrument tip. This is accomplished through the addition of two joints on the master and automatic means for articulating the instrument tip in response to movements made at the master.

The objects and advantages of the present invention will become more readily apparent to those ordinarily skilled in the art after reviewing the following detailed description and drawings wherein:

BRIEF DESCRIPTION OF THE DRAWINGS

Figure 1 is a perspective view of a minimally invasive surgical system in accordance with the present invention;

Figure 2 is a schematic of a master of the system;

Figure 3 is a schematic of a slave of the system;

Figure 4 is a schematic of a control system of the system;

Figure 5 is a schematic showing the instrument in a coordinate frame;

Figure 6 is a schematic of the instrument moving about a pivot point;

Figure 7 is an exploded view of an end effector in accordance with the system of the present invention;

Figure 8 is a view of a master handle of the system in accordance with the present invention;

Figure 8a is a side view of the master handle of the system in accordance with the present invention;

Figures 9-10A-J are illustrations showing an internal mammary artery being grafted to a coronary artery;

Figure 11 is a side view of a rear-loading tool driver in accordance with the system of the present invention;

Figure 12 is a plan view of the motor assembly of the back loading tool driver of Fig. 11;

Figure 13 is a side plan view of an articulable instrument in accordance with the present invention;

Figure 14 is a side plan view of an articulable instrument, where the instrument tip is articulated;

Figure 15 is an exploded view of the articulable portion of the articulable instrument in accordance with the present invention;

Figure 16 is a plan view of a pivot linkage in accordance with the articulate portion of the articulable surgical instrument of the present invention;

Figure 17 is a perspective view of an articulating tool driving assembly in accordance with the present invention;

Figure 18 is a view of a removable tool-tip in accordance with an articulable instrument of the present invention;

Figure 19 is a tool-tip receptacle in accordance with the present invention;

Figure 20 is a cross-sectional view of an articulable instrument attached to the articulate-translator of the present invention;

Figure 21 is a close-up cross section view of the articulate-translator in accordance with the present invention;

Figure 22 is an end view of the articulate translator in accordance with the present invention;

Figure 23 is a cross-sectional view of the sterile section of the articulating tool driving assembly in accordance with the system of the present invention;

Figure 24 is a cross sectional view of the tool driver of the articulating tool driving assembly in accordance with the system of the present invention;

Figure 25 is a schematic of a master of a system in accordance with the present invention that includes the articulating tool driving assembly;

Figure 26 is a plan view of a drape for use with the robotic arm in accordance with the present invention;

Figure 27 is a plan view of a surgical instrument having a stapling tool disposed at the end thereof and wherein the surgical instrument is attached to the robotic arm in accordance with the present invention;

Figure 28 is a plan view of a surgical instrument having a cutting blade disposed at the end thereof wherein the instrument is attached to the robotic arm in accordance with the present invention;

Figure 29 is a plan view of a surgical instrument having a coagulating/cutting device disposed at the end

thereof, the instrument attached to a robotic arm in accordance with the present invention; and

Figure 30 is a plan view of a surgical instrument having a stapling tool disposed at the end thereof and wherein the surgical instrument is attached to the robotic arm in accordance with the present invention.

DETAILED DESCRIPTION OF THE INVENTION

Referring to the drawings more particularly by reference numbers, Figure 1 shows a system 10 that can be used to perform minimally invasive surgery. In a preferred embodiment, the system 10 may be used to perform a minimally invasive coronary artery bypass graft, or Endoscopic coronary artery bypass graft (E-CABG) and other anastomotic procedures. Although a MI-CABG procedure is shown and described, it is to be understood that the system may be used for other surgical procedures. For example, the system can be used to suture any pair of vessels.

The system 10 is used to perform a procedure on a patient 12 that is typically lying on an operating table 14. Mounted to the operating table 14 is a first articulate arm 16, a second articulate arm 18 and a third articulate arm 20. The articulate arms 16-20 are preferably mounted to the table so that the arms are at a same reference plane as the patient. It is to be appreciated that the arms may be mounted to a cart or some other device that places the arms proximate the plane of the patient as well. Although three articulate arms are shown and described, it is to be understood that the system may have any number of arms, such as one or more arms.

The first and second articulate arms 16 and 18 each have a base housing 25 and a robotic arm assembly 26 extending from the base housing 25. Surgical instruments 22 and 24 are preferably removably coupled at the end of

each robotic arm assembly 26 of the first and second articulate arms 16, 18. Each of the instruments 22, 24 may be coupled to a corresponding robotic arm assembly 26 in a variety of fashions which will be discussed in further detail hereinbelow.

The third articulate arm 20 additionally comprises a base housing 25 and a robotic arm assembly 26, and preferably has an endoscope 28 that is attached to the robotic arm assembly 26. The base housing 25 and robotic arm assemblies 26 of each of the articulate arms 16, 18, and 20 are substantially similar. However, it is to be appreciated that the configuration of the third articulate arm 20, may be different as the purpose of the third articulate arm is to hold and position the endoscope 28 as opposed to hold and position a surgical instrument.

The instruments 22 and 24, and endoscope 28 are inserted through incisions cut into the skin of the patient 12. The endoscope 28 has a camera 30 that is coupled to a monitor 32 which displays images of the internal organs of the patient 12.

Each robotic arm assembly 26 has a base motor 34 which moves the arm assembly 26 in a linear fashion, relative to the base housing 25, as indicated by arrows Q. Each robotic arm assembly 26 also includes a first rotary motor 36 and a second rotary motor 38. Each of the robotic arm assemblies 26 also have a pair of passive joints 40 and 42. The passive joints 40, 42 are preferably disposed orthogonal to each other to provide pivotal movement of the instrument 22, 24 or endoscope 28 that is attached to a corresponding robotic arm assembly 26. The passive joints may be spring biased in any specific direction, however, they are not motor driven. The robotic arm assemblies 26 also have a coupling mechanism 45 to couple the instruments 22 and 24, or endoscope 28 thereto. Additionally, each of the

robotic arm assemblies 26 has a motor driven worm gear 44 to rotate the instrument 22, 24 or endoscope 28 attached thereto about its longitudinal axis. More particularly, the motor driven worm gear spins the instruments or endoscope.

The first, second, and third articulate arms 16, 18, 20 are coupled to a controller 46 which can control the movement of the arms. The arms are coupled to the controller 46 via wiring, cabling, or via a transmitter/receiver system such that control signals may be passed from the controller 46 to each of the articulate arms 16, 18, and 20. It is preferable, to ensure error free communication between each of the articulate arms 16, 18 and 20 and the controller 46 that each arm 16, 18, 20 be electrically connected to the controller, and for the purposes of example, each arm 16, 18, 20 is electrically connected to the controller 46 via electrical cabling 47. However, it is possible to control each of the arm 16, 18, 20 remotely utilizing well-known remote control systems as opposed to direct electrical connections. As such remote control systems are well-known in the art, they will not be further discussed herein.

The controller 46 is connected to an input device 48 such as a foot pedal, hand controller, or voice recognition unit. For purposes of example, a foot controller is disclosed herein. The input device 48 can be operated by a surgeon to move the location of the endoscope 28 and view a different portion of the patient by depressing a corresponding button(s) disposed on the input device 48. The controller 46 receives the input signals from the input device 48 and moves the endoscope 28 and robotic arm assembly 26 of the third articulate arm 20 in accordance with the input commands of the surgeon. Each of the robotic arm assemblies 26 may be devices that are sold by the assignee of the present

invention, Computer Motion, Inc. of Goleta, California, under the trademark AESOP. The system is also described in U.S. Patent Number 5,515,478, which is hereby incorporated by reference. Although a foot pedal 49 is shown and described, it is to be understood that the system may have other input means such as a hand controller, or a speech recognition interface.

The movement and positioning of instruments 22, 24 attached to the first and second articulate arms 16 and 18 is controlled by a surgeon at a pair of master handles 50 and 52. Each of the master handles 50, 52 which can be manipulated by the surgeon, has a master-slave relationship with a corresponding one of the articulate arms 16, 18 so that movement of a handle 50 or 52 produces a corresponding movement of the surgical instrument 22, 24 attached to the articulate arm 16, 18.

The handles 50 and 52 may be mounted to a portable cabinet 54. A second television monitor 56 may be placed onto the cabinet 54 and coupled to the endoscope 28 via well-known means so that the surgeon can readily view the internal organs of the patient 12. The handles 50 and 52 are also coupled to the controller 46. The controller 46 receives input signals from the handles 50 and 52, computes a corresponding movement of the surgical instruments, and provides output signals to move the robotic arm assemblies 26 and instruments 22, 24. Because the surgeon may control the movement and orientation of the instruments 22, 24 without actually holding the ends of the instruments, the surgeon may use the system 10 of the present invention both seated or standing. One advantage of the present system is that a surgeon may perform endoscopic surgeries in a sitting position. This helps reduce surgeon fatigue and may improve performance and outcomes in the operating room, especially during those procedures that are many hours

in length. To accommodate a seated position, a chair 57 may be provided with the system.

Each handle has multiple degrees of freedom provided by the various joints Jm1-Jm5 depicted in Figure 2. Joints Jm1 and Jm2 allow the handle to rotate about a pivot point in the cabinet 54. Joint Jm3 allows the surgeon to move the handle into and out of the cabinet 54 in a linear manner. Joint Jm4 allows the surgeon to rotate the master handle about a longitudinal axis of the handle. The joint Jm5 allows a surgeon to open and close a gripper.

Each joint Jm1-Jm5 has one or more position sensors which provides feedback signals that correspond to the relative position of the handle. The position sensors may be potentiometers, or any other feedback device such as rotary optical encoders that provides an electrical signal which corresponds to a change of position. Additionally, a plurality of position sensors may be emplaced at each joint to provide redundancy in the system which can be used to alert a surgeon of malfunctions or improper positioning of a corresponding robotic arm assembly 26.

In addition to position sensors, each joint may include tachometers, accelerometers, and force sensing load cells, each of which may provide electrical signals relating to velocity, acceleration and force being applied at a respective joint. Additionally, actuators may be included at each joint to reflect force feed back received at a robotic arm assembly 26. This may be especially helpful at joint jm5 to indicate the force encountered inside a patient by the gripper disposed at the end of one of the tools 22, or 24. As such, a force reflective element must be included at the gripper of the instrument 22, 24 to effectuate such a force reflective feedback loop. Force reflective elements, such as a piezoelectric element in combination with a

whetstone bridge are well-known in the art. However, it is not heretofore known to utilize such force reflection with such a system 10.

Figure 3 shows the various degrees of freedom of each articulate arm 16 and 18. The joints Js1, Js2 and Js3 correspond to the axes of movement of the base motor 34 and rotary motors 36, 38 of the robotic arm assemblies 26, respectively. The joints Js4 and Js5 correspond to the passive joints 40 and 42 of the arms 26. The joint Js6 may be a motor which rotates the surgical instruments about the longitudinal axis of the instrument. The joint Js7 may be a pair of fingers that can open and close. The instruments 22 and 24 move about a pivot point P located at the incision of the patient.

Figure 4 shows a schematic of a control system that translates a movement of a master handle into a corresponding movement of a surgical instrument. In accordance with the control system shown in Fig. 4, the controller 46 computes output signals for the articulate arms so that the surgical instrument moves in conjunction with the movement of the handle. Each handle may have an input button 58 which enables the instrument to move with the handle. When the input button 58 is depressed the surgical instrument follows the movement of the handle. When the button 58 is released the instrument does not track the movement of the handle. In this manner the surgeon can adjust or "ratchet" the position of the handle without creating a corresponding undesirable movement of the instrument. The "ratchet" feature allows the surgeon to continuously move the handles to more desirable positions without altering the positions of the arms. Additionally, because the handles are constrained by a pivot point the ratchet feature allows the surgeon to move the instruments beyond the dimensional limitations of the

handles. Although an input button 58 is shown and described, it is to be understood that the surgical instrument may be activated by other means such as voice recognition. The input button may alternatively be latched so that movement of the corresponding instrument toggles between active and inactive each time the button is depressed by the surgeon.

When the surgeon moves a handle, the position sensors provide feedback signals M1-M5 that correspond to the movement of the joints Jm1-Jm5, respectively. The controller 46 computes the difference between the new handle position and the original handle position in computation block 60 to generate incremental position values M1-M5.

The incremental position values M1- M5 are multiplied by scale factors S1-S5, respectively in block 62. The scale factors are typically set at less than one so that the movement of the instrument is less than the movement of the handle. In this manner the surgeon can produce very fine movements of the instruments with relatively coarse movements of the handles. The scale factors S1-S5 are variable so that the surgeon can vary the resolution of instrument movement. Each scale factor is preferably individually variable so that the surgeon can more finely control the instrument in certain directions. By way of example, by setting one of the scale factors at zero the surgeon can prevent the instrument from moving in one direction. This may be advantageous if the surgeon does not want the surgical instrument to contact an organ or certain tissue located in a certain direction relative to the patient. Although scale factors smaller than a unit one are described, it is to be understood that a scale factor may be greater than one. For example, it may be desirable to spin the instrument at a greater rate than a corresponding spin of the handle.

The controller 46 adds the incremental values $_M1$ - $_M5$ to the initial joint angles $Mj1$ - $Mj5$ in adder element 64 to provide values $Mr1$ - $Mr5$. The controller 46 then computes desired slave vector calculations in computation block 66 in accordance with the following equations.

$$Rdx = Mr3 \cdot \sin(Mr1) \cdot \cos(Mr2) + Px$$

$$Rdy = Mr3 \cdot \sin(Mr1) \cdot \sin(Mr2) + Py$$

$$Rdz = Mr3 \cdot \cos(Mr1) + Pz$$

$$Sdr = Mr4$$

$$Sdg = Mr5$$

where;

Rdx, y, z = the new desired position of the end effector of the instrument.

Sdr = the angular rotation of the instrument about the instrument longitudinal axis.

Sdg = the amount of movement of the instrument fingers.

Px, y, z = the position of the pivot point P.

The controller 46 then computes the movement of the robotic arm 26 in computational block 68 in accordance with the following equations.

$$Jsd1 = Rdz$$

$$Jsd3 = \pi - \cos^{-1} \left[\frac{Rdx^2 + Rdy^2 - L1^2 - L2^2}{2 L1 \cdot L2} \right]$$

$$Jsd2 = \tan^{-1}(Rdy / Rdx) + \Delta \quad \text{for } Jsd3 \leq 0$$

$$Jsd2 = \tan^{-1}(Rdy / Rdx) - \Delta \quad \text{for } Jsd3 > 0$$

$$\Delta = \cos^{-1} \left[\frac{Rdx^2 + Rdy^2 - L1^2 - L2^2}{2 \cdot L1 \sqrt{Rdx^2 + Rdy^2}} \right]$$

$$Jsd6 = Mr4$$

$$Jsd7 = Mr5$$

where;

Jsd1 = the movement of the linear motor.

Jsd2 = the movement of the first rotary motor.

Jsd3 = the movement of the second rotary motor.

Jsd6 = the movement of the rotational motor.

Jsd7 = the movement of the gripper.

L1 = the length of the linkage arm between the first rotary motor and the second rotary motor.

L2 = the length of the linkage arm between the second rotary motor and the passive joints.

The controller provides output signals to the motors to move the arm and instrument in the desired location in block 70. This process is repeated for each movement of the handle.

The master handle will have a different spatial position relative to the surgical instrument if the surgeon releases, or toggles, the input button and moves the handle. When the input button 58 is initially depressed, the controller 46 computes initial joint angles Mj1-Mj5 in computational block 72 with the following equations.

$$Mj1 = \tan^{-1}(ty / tx)$$

$$Mj2 = \tan^{-1}(d / tz)$$

$$Mj3 = D$$

$$Mj4 = Js6$$

$$Mj5 = Js7$$

$$d = \sqrt{tx^2 + ty^2}$$

$$tx = \frac{R_{sx} - Px}{D} \quad ty = \frac{R_{sy} - Py}{D} \quad tz = \frac{R_{sz} - Pz}{D}$$

$$D = \sqrt{(R_{sx} - Px)^2 + (R_{sy} - Py)^2 + (R_{sz} - Pz)^2}$$

The forward kinematic values are computed in block 74 with the following equations.

$$\begin{aligned} R_{sx} &= L1 \cdot \cos(Js2) + L2 \cdot \cos(Js2 + Js3) \\ R_{sy} &= L1 \cdot \cos(Js2) + L2 \cdot \sin(Js2 + Js3) \\ R_{sz} &= J1 \end{aligned}$$

The joint angles M_j are provided to adder 64. The pivot points P_x , P_y and P_z are computed in computational block 76 as follows. The pivot point is calculated by initially determining the original position of the intersection of the end effector and the instrument P_0 , and the unit vector U_0 which has the same orientation as the instrument. The position $P(x, y, z)$ values can be derived from various position sensors of the robotic arm. Referring to Figure 5 the instrument is within a first coordinate frame (x, y, z) which has the angles θ_4 and θ_5 . The unit vector U_0 is computed by the transformation matrix:

$$U_0 = \begin{bmatrix} \cos\theta_5 & 0 & -\sin\theta_5 \\ -\sin\theta_4 \sin\theta_5 & \cos\theta_4 & -\sin\theta_4 \cos\theta_5 \\ \cos\theta_4 \sin\theta_5 & \sin\theta_4 & \cos\theta_4 \end{bmatrix} \begin{bmatrix} 0 \\ 0 \\ -1 \end{bmatrix}$$

After each movement of the end effector an angular movement of the instrument $\Delta\theta$ is computed by taking the arcsin of the cross-product of the first and second unit vectors U_0 and U_1 of the instrument in accordance with the following line equations L_0 and L_1 .

where;

T = a vector which is a cross-product of unit vectors U_0 and U_1 .

The unit vector of the new instrument position U1 is again determined using the position sensors and the transformation matrix described above. If the angle is greater than a threshold value, then a new pivot point is calculated and Uo is set to U1. As shown in Figure 6, the first and second instrument orientations can be defined by the line equations Lo and L1:

Lo:

$$x_0 = M_{x0} \cdot Z_0 + C_{x0}$$

$$y_0 = M_{y0} \cdot Z_0 + C_{y0}$$

L1:

$$x_1 = M_{x1} \cdot Z_1 + C_{x1}$$

$$y_1 = M_{y1} \cdot Z_1 + C_{y1}$$

where;

Z₀ = a Z coordinate along the line L₀ relative to the z axis of the first coordinate system.

Z₁ = a Z coordinate along the line L₁ relative to the z axis of the first coordinate system.

M_{x0} = a slope of the line L₀ as a function of Z₀.

M_{y0} = a slope of the line L₀ as a function of Z₀.

M_{x1} = a slope of the line L₁ as a function of Z₁.

M_{y1} = a slope of the line L₁ as a function of Z₁.

C_{x0} = a constant which represents the intersection of the line L₀ and the x axis of the first coordinate system.

C_{y0} = a constant which represents the intersection of the line L₀ and the y axis of the first coordinate system.

C_{x1} = a constant which represents the intersection of the L₁ and the x axis of the first coordinate system.

Cy1 = a constant which represents the intersection of the line L1 and the y axis of the first coordinate system.

The slopes are computed using the following algorithms:

$$Mx0 = Ux0/Uz0$$

$$My0 = Uy0/Uz0$$

$$Mx1 = Ux1/Uz1$$

$$My1 = Uy1/Uz1$$

$$Cx0 = Pox - Mx1 \cdot Poz$$

$$Cy0 = Poy - My1 \cdot Poz$$

$$Cx1 = Plx - Mx1 \cdot Plz$$

$$Cy1 = Ply - My1 \cdot Plz$$

where;

Uo(x, y and z) = the unit vectors of the instrument in the first position within the first coordinate system.

U1(x, y and z) = the unit vectors of the instrument in the second position within the first coordinate system.

Po(x, y and z) = the coordinates of the intersection of the end effector and the instrument in the first position within the first coordinate system.

P1(x, y and z) = the coordinates of the intersection of the end effector and the instrument in the second position within the first coordinate system.

To find an approximate pivot point location, the pivot points of the instrument in the first orientation L0 (pivot point R0) and in the second orientation L1 (pivot point R1) are determined, and the distance half way between the two points R0 and R1 is computed and stored as the pivot point Rave of the instrument. The

pivot point R_{ave} is determined by using the cross-product vector T .

To find the points R_0 and R_1 the following equalities are set to define a line with the same orientation as the vector T that passes through both L_0 and L_1 .

$$tx = Tx/Tz$$

$$ty = Ty/Tz$$

where;

tx = the slope of a line defined by vector T relative to the Z-x plane of the first coordinate system.

ty = the slope of a line defined by vector T relative to the Z-y plane of the first coordinate system.

T_x = the x component of the vector T .

T_y = the y component of the vector T .

T_z = the z component of the vector T .

Picking two points to determine the slopes T_x , T_y and T_z (eg. $T_x = x_1 - x_0$, $T_y = y_1 - y_0$ and $T_z = z_1 - z_0$) and substituting the line equations L_0 and L_1 , provides a solution for the point coordinates for R_0 (x_0 , y_0 , z_0) and R_1 (x_1 , y_1 , z_1) as follows.

$$z_0 = ((M_{x1} - tx)z_1 + C_{x1} - C_{x0}) / (M_{x0} - tx)$$

$$z_1 = \frac{((C_{y1} - C_{y0})(M_{x0} - tx) - (C_{x1} - C_{x0})(M_{y0} - ty))}{((M_{y0} - ty)(M_{x1} - tx) - (M_{y1} - ty)(M_{x0} - tx))}$$

$$y_0 = M_{y0} \cdot z_0 + C_{y0}$$

$$y_1 = M_{y1} \cdot z_1 + C_{y1}$$

$$x_0 = M_{x0} \cdot z_0 + C_{x0}$$

$$x_1 = M_{x1} \cdot z_1 + C_{x1}$$

The average distance between the pivot points R_0 and R_1 is computed with the following equation and stored as the pivot point of the instrument.

$$R_{ave} = ((x_1 + x_0) / 2, (y_1 + y_0) / 2, (z_1 + z_0) / 2)$$

The pivot point can be continually updated with the above described algorithm routine. Any movement of the pivot point can be compared to a threshold value and a warning signal can be issued or the robotic system can become disengaged if the pivot point moves beyond a set limit. The comparison with a set limit may be useful in determining whether the patient is being moved, or the instrument is being manipulated outside of the patient, situations which may result in injury to the patient or the occupants of the operating room.

To provide feedback to the surgeon the fingers of the instruments may have pressure sensors that sense the reacting force provided by the object being grasped by the end effector. Referring to Fig. 4, the controller 46 receives the pressure sensor signals F_s and generates corresponding signals C_m in block 78 that are provided to an actuator located within the handle. The actuator provides a corresponding pressure on the handle which is transmitted to the surgeon's hand. The pressure feedback allows the surgeon to sense the pressure being applied by the instrument. As an alternate embodiment, the handle may be coupled to the end effector fingers by a mechanical cable that directly transfers the grasping force of the fingers to the hands of the surgeon.

Figure 7 shows a preferred embodiment of an end effector 80 that may be used in the present invention. The end effector 80 includes a surgical instrument 82, such as those disclosed hereinabove 22, 24, that is coupled to a front loading tool driver 84. The end

effector 80 is mounted to one of the robotic arm assemblies 26 by coupling mechanism 45. The coupling mechanism 45 includes a collar 85 that removably attaches to a holder 86. The holder 86 includes a worm gear 87 that is driven by a motor in the robotic arm assembly 26 to rotate the collar 85 and in turn rotate the instrument 82 about its longitudinal axis. The holder 86 includes a shaft 88 that seats into a slot in the robotic arm assembly 26. The shaft 88 may be turned by the motor in the arm assembly, which then rotates the worm gear 87 thus rotating the collar 86 and the instrument 82. A tightening tool 89 may be employed to tighten and loosen the collar about the instrument 82. Such a tool operates like a chuck key, to tighten and loosen the collar 86.

The surgical instrument 82 has a first finger 90 that is pivotally connected to a second finger 91. The fingers 90, 91 can be manipulated to hold objects such as tissue or a suturing needle. The inner surface of the fingers may have a texture to increase the friction and grasping ability of the instrument 82. The first finger 90 is coupled to a rod 92 that extends through a center channel 94 of the instrument 82. The instrument 82 may have an outer sleeve 96 which cooperates with a spring biased ball quick disconnect fastener 98. The quick disconnect 98 allows instruments other than the finger grasper to be coupled to front loading tool driver 84. For example, the instrument 82 may be decoupled from the quick disconnect 98 and replaced by a cutting tool, a suturing tool, a stapling tool adapted for use in this system, such as the stapling apparatus disclosed in U.S. Patent No. 5,499,990 or 5,389,103 assigned to Karlsruhe, a cutting blade, or other surgical tools used in minimally invasive surgery. The quick disconnect 98 allows the surgical instruments to be interchanged without having to re-sterilize the front

loading tool driver 84 each time an instrument is plugged into the tool driver 84. The operation of the front loading tool driver 84 shall be discussed in further detail hereinbelow.

The quick disconnect 98 has a slot 100 that receives a pin 102 of the front loading tool driver 84. The pin 102 locks the quick disconnect 98 to the front loading tool driver 100. The pin 102 can be released by depressing a spring biased lever 104. The quick disconnect 98 has a piston 106 that is attached to the tool rod 92 and in abutment with an output piston 108 of a load cell 110 located within the front loading tool driver 84.

The load cell 110 is mounted to a lead screw nut 112. The lead screw nut 112 is coupled to a lead screw 114 that extends from a gear box 116. The gear box 116 is driven by a reversible motor 118 that is coupled to an encoder 120. The entire end effector 80 is rotated by the motor driven worm gear 87.

In operation, the motor 118 of the front loading tool driver 84 receives input commands from the controller 46 via electrical wiring, or a transmitter/receiver system and activates, accordingly. The motor 118 rotates the lead screw 114 which moves the lead screw nut 112 and load cell 110 in a linear manner. Movement of the load cell 110 drives the coupler piston 106 and tool rod 92, which rotate the first finger 88. The load cell 110 senses the counteractive force being applied to the fingers and provides a corresponding feedback signal to the controller 46.

The front loading tool driver 84 may be covered with a sterile drape 124 so that the tool driver 84 does not have to be sterilized after each surgical procedure. Additionally, the robotic arm assembly 26 is preferably covered with a sterile drape 125 so that it does not have to be sterilized either. The drapes 124, 125 serve

substantially as a means for enclosing the front loading tool driver 84 and robotic arm assembly 26. The drape 125 used to enclose the robotic arm assembly 26 is depicted in further detail in Figure 26. The drape 125 has a substantially open end 300 wherein the robotic arm assembly 26 may be emplaced into the drape 125. The drape 125 additionally includes a substantially tapered enclosed end 302 that effectively separates the arm assembly 26 from the operating room environment. A washer 304 having a small aperture 306 formed therethrough allows an instrument to be coupled to the arm assembly 26 via the coupling mechanism 45. The washer 304 reinforces the drape 125 to ensure that the drape 125 does not tear as the arm assembly 26 moves about. Essentially, the instrument cannot be enclosed in the drape 125 because it is to be inserted into the patient 12. The drape 125 also includes a plurality of tape 308 having adhesive 310 disposed thereon. At least one piece of tape 308 is oppositely arranged the other pieces of tape 308 to effectuate the closing of the drape 125 about the arm assembly 26.

Figures 8 and 8a show a preferred embodiment of a master handle assembly 130. The master handle assembly 130 includes a master handle 132 that is coupled to an arm 134. The master handle 132 may be coupled to the arm 134 by a pin 136 that is inserted into a corresponding slot 138 in the handle 132. The handle 132 has a control button 140 that can be depressed by the surgeon. The control button 140 is coupled to a switch 142 by a shaft 144. The control button 140 corresponds to the input button 58 shown in Fig. 4, and activates the movement of the end effector.

The master handle 132 has a first gripper 146 that is pivotally connected to a second stationary gripper 148. Rotation of the first gripper 146 creates a corresponding linear movement of a handle shaft 150.

The handle shaft 150 moves a gripper shaft 152 that is coupled a load cell 154 by a bearing 156. The load cell 154 senses the amount of pressure being applied thereto and provides an input signal to the controller 46. The controller 46 then provides an output signal to move the fingers of the end effector.

The load cell 154 is mounted to a lead screw nut 158 that is coupled to a lead screw 160. The lead screw 160 extends from a reduction box 162 that is coupled to a motor 164 which has an encoder 166. The controller 46 of the system receives the feedback signal of the load cell 110 in the end effector and provides a corresponding command signal to the motor to move the lead screw 160 and apply a pressure on the gripper so that the surgeon receives feedback relating to the force being applied by the end effector. In this manner the surgeon has a "feel" for operating the end effector.

The handle is attached to a swivel housing 168 that rotates about bearing 170. The swivel housing 168 is coupled to a position sensor 172 by a gear assembly 174. The position sensor 172 may be a potentiometer which provides feedback signals to the controller 46 that correspond to the relative position of the handle. Additionally, an optical encoder may be employed for this purpose. Alternatively, both a potentiometer and an optical encoder may be used to provide redundancy in the system. The swivel movement is translated to a corresponding spin of the end effector by the controller and robotic arm assembly.

The arm 134 may be coupled to a linear bearing 176 and corresponding position sensor 178 which allow and sense linear movement of the handle. The linear movement of the handle is translated into a corresponding linear movement of the end effector by the controller and robotic arm assembly. The arm can pivot about bearings 180, and be sensed by position sensor 182

located in a stand 184. The stand 184 can rotate about bearing 186 which has a corresponding position sensor 188. The arm rotation is translated into corresponding pivot movement of the end effector by the controller and robotic arm assembly.

A human hand will have a natural tremor typically resonating between 6-12 hertz. To eliminate tracking movement of the surgical instruments with the hand tremor, the system may have a filter that filters out any movement of the handles that occurs within the tremor frequency bandwidth. Referring to Figure 4, the filter 184 may filter analog signals provided by the potentiometers in a frequency range between 6-12 hertz. Alternatively, an optical encoder and digital filter may be used for this purpose.

As shown in Figures 9 and 10A-J, the system is preferably used to perform a cardiac procedure such as a coronary artery bypass graft (CABG). The procedure is performed by initially cutting three incisions in the patient and inserting the surgical instruments 22 and 24, and the endoscope 26 through the incisions. One of the surgical instruments 22 holds a suturing needle and accompanying thread when inserted into the chest cavity of the patient. If the artery is to be grafted with a secondary vessel, such as a saphenous vein, the other surgical instrument 24 may hold the vein while the end effector of the instrument is inserted into the patient.

The internal mammary artery (IMA) may be severed and moved by one of the instruments to a graft location of the coronary artery. The coronary artery is severed to create an opening in the artery wall of a size that corresponds to the diameter of the IMA. The incision(s) may be performed by a cutting tool that is coupled to one of the end effectors and remotely manipulated through a master handle. The arteries are clamped to prevent a blood flow from the severed mammary and

coronary arteries. The surgeon manipulates the handle to move the IMA adjacent to the opening of the coronary artery. Although grafting of the IMA is shown and described, it is to be understood that another vessel such as a severed saphaneous vein may be grafted to bypass a blockage in the coronary artery.

Referring to Figs. 10A-J, the surgeon moves the handle to manipulate the instrument into driving the needle through the IMA and the coronary artery. The surgeon then moves the surgical instrument to grab and pull the needle through the coronary and graft artery as shown in Fig. 10B. As shown in Fig. 10C, the surgical instruments are then manipulated to tie a suture at the heel of the graft artery. The needle can then be removed from the chest cavity. As shown in Figs. 10D-F, a new needle and thread can be inserted into the chest cavity to suture the toe of the graft artery to the coronary artery. As shown in Fig. 10H-J, new needles can be inserted and the surgeon manipulates the handles to create running sutures from the heel to the toe, and from the toe to the heel. The scaled motion of the surgical instrument allows the surgeon to accurately move the sutures about the chest cavity. Although a specific graft sequence has been shown and described, it is to be understood that the arteries can be grafted with other techniques. In general the system of the present invention may be used to perform any minimally invasive anastomotic procedure.

As disclosed hereinabove, the system may include a front loading tool driver 84 which receives control signals from the controller 46 in response to movement of a master handle 50 or 52 and drives the tool disposed at the end of a surgical instrument. Alternatively, a back loading tool driver 200 may be incorporated into the system 10 of the present invention, as depicted in Figures 11 and 11a. The back loading tool driver 200

cooperates with a back loadable surgical instrument 202. The incorporation of such a back loading tool driver 200 and instrument 202 expedites tool changing during procedures, as tools may be withdrawn from the tool driver 200 and replaced with other tools in a very simple fashion.

The back loading tool driver 200 is attached to a robotic arm assembly 26 via a collar and holder as disclosed hereinabove. The back loading tool driver includes a sheath 204 having a proximal end 206 and a distal end 208. The sheath 204 may be formed of plastic or some other well-known material that is used in the construction of surgical instruments. The sheath 204 is essentially a hollow tube that fits through the collar 85 and is tightened in place by the tightening tool that is described in more detail hereinabove.

The back loadable surgical instrument 202 has a tool end 210 and a connecting end 212. A surgical tool 214, such as a grasper or some other tool that may be driven by a push/pull rod or cable system, or a surgical tool that does not require such a rod or cable, such as a coagulator, or harmonic scalpel is disposed at the tool end 210 of the instrument 202.

A housing 216 is disposed at the connecting end 212 of the instrument 202. The housing has a lever 218 disposed interiorly the housing 216. The lever 218 has a pivot point 220 that is established by utilizing a pin passing through an associated aperture 222 in the lever. The pin may be attached to the interior wall 224 of the housing. A push/pull cable or rod 226, that extends the length of the instrument 202 is attached to the lever 218, such that movement of the lever 218 about the pivot point 220 results in a linear movement of the cable or rod 226. Essentially the cable or rod 226 serves as a means 227 for actuating the tool 214 at the tool end 210 of the instrument 202. The cable or rod 226 may be

attached to the lever via a connection pin as well. The lever 218 has a C-shape, wherein the ends of the lever 218 protrude through two apertures 228, 230 in the housing 216. The apertures 228, 230 are preferably surrounded by O-rings 232 the purpose of which shall be described in more detail hereinbelow.

The tool end 210 of the back loadable surgical instrument 202 is emplaced in the hollow tube of the back loading tool driver 200. The tool 202 may be pushed through the tool driver until the tool end 210 extends beyond the sheath 204. The O-rings 232 seat in associated apertures 234, 236 in a housing 238 of the tool driver 200. The housing additionally has an aperture 240 centrally formed therethrough, the aperture being coaxial with the interior of the hollow tube. In this fashion, the surgical instrument 202 may be inserted into and through the tool driver 200. Each of the O-rings 232 snugly seats in its associated aperture in the housing 238 of the tool driver 200.

The housing 238 additionally includes a motor assembly 242 which is depicted in Figure 11a. The motor assembly 242 is attached to the housing 238 and is held firmly in place therein. The motor assembly generally includes a motor 244 attached to a reducer 246. The motor drives a leaf 248 attached at the end thereof. The leaf 248 engages the ends of the lever 218 such that rotational movement of the motor results in the movement of the lever 218 about the pivot point 220. This in turn results in the lateral movement of the means 227 for actuating the tool 214 at the tool end 210 of the instrument 202. The motor moves in response to movements at a control handle. Additionally, force sensors 248, 250 may be attached at the ends of the leaf 248. As such, a force feedback system may be incorporated to sense the amount of force necessary to actuate the tool 214 at the tool end 210 of the

instrument 202. Alternatively, the motor 244 may have a force feedback device 252 attached thereto, which can be used in a similar fashion.

One advantage of utilizing the back loading tool driver 200 is that the sheath 204 always remains in the patient 12. As such, the tools do not have to be realigned, nor does the robotic arm assembly 26 when replacing or exchanging tools. The sheath 204 retains its position relative to the patient 12 whether or not a tool is placed therethrough.

The system 10 of the present invention may additionally be supplied with one or two additional degrees of freedom at the tip of an instrument. For the purposes of example, two additional degrees of freedom will be disclosed; however it is to be appreciated that only one degree of freedom may be included as well. To provide the additional degrees of freedom, and as depicted in Figures 13-16, an articulable surgical instrument 300 may be incorporated into the present. The instrument 300 may be coupled to the arm assembly 26 via a collar and holder as disclosed hereinabove. In order to articulate the tip of the articulable instrument 300 an articulating tool driver 500 must be employed. The articulating tool driver 500 shall be described in more detail hereinbelow. The master must have an additional two degrees of freedom added thereto to provide the controls for the articulation at the tip of the instrument 300. Figure 25 depicts an alternative master schematic that includes the two additional degrees of freedom. As disclosed hereinbelow, the two additional degrees of freedom are mapped to the articulable portion of the instrument 300. The two additional axes at the master are referred to as Jm6 and Jm7.

By incorporating the articulable instrument 300 and the articulating tool driver 500 and the additional

degrees of freedom at the master, difficult maneuvers may be carried out in an easier fashion.

With reference to figs. 13-16, the articulable instrument 300 generally includes an elongated rod 302, a sheath 304, and a tool 306. The tool can be a grasper, a cutting blade, a retractor, a stitching device, or some other well-known tool used in minimally invasive surgical procedures. Figures 27-30 show various tools that may be emplaced at the distal end of the articulable surgical instrument 300.

The instrument 300 includes an articulable portion 301 having a proximal portion 308, a pivot linkage 310 and a distal portion 212 each of which will be discussed in more detail hereinbelow. Additionally, the instrument 300 includes means 311 for articulating the articulable portion 301 of the instrument 300 with respect to the elongated rod 302. The inclusion of the articulable portion 301 provides two additional degrees of freedom at the instrument tip. It must also be appreciated that although the articulable portion 301 is described as including a proximal portion, a pivot linkage and a distal portion, there may be provided a plurality of intermediate portions each mounted to each other via a corresponding pivot linkage.

Disposed between and mounted to each of the respective proximal portion and distal portion and any intervening intermediate portions are pivot linkages 310. The pivot linkage 310 interengages with the proximal and distal portions of the articulable portion to provide articulation at the instrument tip. Essentially, the cooperation of the proximal portion, pivot linkage and distal portion serves as a universal joint.

The elongated rod 302 is preferably hollow and formed of stainless steel or plastic or some other well-known material that is sterilizable. Because the rod 302

is hollow, it encompasses and defines an interior 314. The elongated rod 302 additionally has a proximal end 316 and a distal end 318. The distal end 318 of the elongated rod 302 should not be confused with the distal portion 312 of the articulable portion 301 of the instrument 300.

The proximal portion 308 of the articulable portion 301 may be integrally formed with the elongated rod 302 or it may be attached thereto via welding, glue or some other means well-known to the skilled artisan. It is preferable that the proximal portion 308 be integrally formed with the elongated rod 302 to ensure sufficient stability and durability of the instrument 300. The proximal portion 308 of the articulable portion 301 comprises two fingers 320, 322 each of which have an aperture 324, 326 formed therethrough.

A pivot linkage 310 is mounted to the proximal portion 308 via a plurality of pins 328 that each pass through an associated aperture in an adjoining finger. The pivot linkage 310 is a generally flat disk 330 having a central aperture 332 passing therethrough and four apertures 334, 336, 338, 340 evenly spaced at the periphery of the disk 330. Additionally pins 328 are attached to and extend from the edge 342. The pins 328 seat in the apertures of the associated fingers to provide the articulability of the instrument 300. Five leads 350, 352, 354, 356, 358 extend interiorly the hollow shaft. One lead 350 extends down the center and passes through the center aperture 332 in the pivot linkage 310. Two 352, 354 of the five leads extend down the hollow interior of the instrument and are attached to the pivot linkage such that linear tension on one of the leads results in rotational movement of the pivot portion 301. These two leads 352, 354 attach to the pivot linkage at two of the apertures formed therethrough. Additionally, they attach at those

apertures that are adjacent to the pins that pass through the fingers of the proximal portion 308 of the articulable portion 301 of the instrument 300. The other two leads 356, 358 pass through the two other apertures in the pivot linkage and attach at the distal end of the articulable portion 301. Movement of these two leads results in movement of the articulable portion 301 that is orthogonal to the movement when the two other leads 352, 354 are moved.

To articulate the instrument as a part of the present system, and as depicted in Figures 17-24, there is provided an articulating mechanism 400. The articulating mechanism 400 generally comprises the articulating tool driver 500, a sterile coupler 600, a translator 700 and the articulable tool 300.

The translator is attached to the proximal end 316 of the instrument 300. The instrument 300 may additionally have a removable tool 420 as shown in Figs. 18-19. The removable tool 420 may be any tool, such as a cutter 422 that is attached to an elongated rod or cable 424. At the end of the rod 246 there is disposed a flat section 428 with an aperture 430 formed therethrough. The flat section 428 seats into a channel 432 disposed at the end of a second cable or rod 434 that travels down the elongated shaft of the instrument 300. The second cable 434 has a channel 432 formed in the end thereof such that the flat section 428 seats in the channel 432. At least one spring biased detent 436 seats in the aperture 430 disposed through the flat section 428. This connects the tool 420 to the rest of the instrument 300. As such, tools may be exchanged at the tip of the instrument without having to remove the instrument from the system 10 every time a new tool is required.

The tool 300 is attached to the translator 700 and essentially is integrally formed therewith. The

articulating mechanism 400 is attached to the robotic arm assembly 26 via the collar 85 as is disclosed hereinabove. The collar 85 fits about the shaft 302 of the instrument 300.

The translator 700 has a proximal end 702 and a distal end 704. The distal end 704 of the translator 700 has a cross sectional shape that is substantially similar to the cross sectional shape of the elongated rod 302 of the instrument 300. Additionally, the translator 700 has a hollow interior 706. The center rod 350 extends through the hollow interior 706 of the translator 700 and emerges at the proximal end 702 thereof. Two of the leads 352, 354 terminate interiorly the translator at two shoulders 708, 710 that are attached to a first hollow tube 712 through which the center lead 350 extends. The first hollow tube 712 may be formed of some strong durable material such as stainless steel, steel, hard plastic or the like.

The first hollow tube 712 is mounted to a bearing 714 such that it may be rotated. Rotation of the first hollow tube 712 results in the linear motion of the leads 352, 254 and the articulation of the articulable portion 301 of the instrument 300 in one plane of motion.

A second hollow tube 716 has a pair of shoulders 718, 719 extending therefrom. Two leads 356, 358 attach to one each of the shoulders 718, 719. The hollow tube 716 is disposed within a bearing assembly 720 such that it may be rotated. Again, rotation of the second hollow tube 716 results in linear movement of the leads 356, 358 which articulates the articulable portion 301 of the instrument 300 in a plane orthogonal the plane of motion established through the rotation of the first hollow tube. It is to be appreciated that the second hollow tube 714 radially surrounds the first hollow tube 712. The translator 700 additionally includes a quick

disconnect 722 comprising a pin 724 disposed at the end of a spring biased lever 726 which provides removable attachment of the translator 700 to the sterile coupler 600. Both of the hollow tubes 712 and 716 may have notches 750 formed therein at their ends. The notches serve as a means 752 for interconnecting each of the tubes to the sterile coupler 600 which will be discussed in further detail hereinbelow.

The translator 700 is removably attached to the sterile coupler 600 via the quick disconnect 722. Because the articulable tool driver 500 is not easily sterilized, it is advantageous to include a sterile coupler 600 so that instruments may be exchanged without having to sterilize the articulable tool driver 500. Additionally, the coupler 600 provides a means by which the translator 700 may be attached to the tool driver 500 while the tool driver is enclosed in a drape 125 such as that depicted in figure 26. The translator 600 has a housing 610. Preferably the housing and the components of the coupler 600 are formed of some easily sterilizable material such as stainless steel, plastics or other well-known sterilizable materials. The housing 610 has a substantially hollow interior 612 and open ends 614 and 616. Two hollow tubes 618 and 620 are rotatively disposed within the housing 610. To effectuate the rotation of each of the tubes 618 and 620, bearings 622 and 624 are disposed about each of the tubes. Each of the tubes has notches 626 formed in the ends thereof so effectuate the attachment of the translator 700 to the coupler 600 at one end. And to effectuate the attachment of the coupler 600 to the articulable tool driver 500 at the other end thereof.

The pin 724 on the translator may seat in a notch 628 to attach the translator 700 to the coupler 600. Additionally, the coupler 600 may include a pin 630 attached to a spring biased pivot 632 to effectuate

attachment of the coupler to the driver 500. The coupler 600 additionally includes a center section 634 that slidably receives the end 351 of the center cable or rod 350. The end 351 may include a tip with a circumferential groove 353 disposed thereabout. The tip seats in a recess 636 formed in the center section 634 and is removably locked in place by at least one spring biased detent 638. A tip 640, which is substantially similar to the tip containing the circumferential groove 353 is disposed adjacent the recess 636 and serves to attach the cable center cable 350 to the articulable tool driver 500, which will be discussed in further detail hereinbelow.

The center section 634 is intended to laterally slide within the innermost tube 618. To effectuate such a sliding motion, a linear bearing may be disposed about the center section interiorly of the innermost tube. Alternatively, the center section 634 may be formed of a bearing material that provides smooth sliding within the innermost tube 618.

The coupler 600 is removably attached to the articulable tool driver 500. It is intended that the articulable tool driver be enclosed by a drape 125. The articulable tool driver 500 includes a substantially hollow housing 502 having a closed first end 504 and a substantially open second end 504. Securely disposed interiorly the housing 502 is a gripper motor 506, and a pair of wrist motors 508 and 510. Each of the motors are in electrical connection with the controller 46. Alternatively, the motors may receive signals from the controller via a transmitter/receiver system where such systems are well known. It is the application of such a transmitter/receiver system to the present invention that is new. The gripper motor 506 is attached to a load nut 510 that surrounds a load screw 512. The motor 506 receives the control signals and turns in response

thereto. The load nut 510 turns which laterally moves the load screw 512. The load screw 512 is attached to a load cell 514 which may be employed to measure the force required to laterally move the cable 350 which is attached via the coupler 600 to the gripper motor 506. This may be used in a force feedback system that may be incorporated in the system 10 of the present invention. A rod 516 having a channel 518 formed at the end thereof is attached to the load cell 514. As such, the rod 516 moves in a linear fashion. The tip 640 of the coupler 600 seats in the channel 518 and is removably held in place by at least one spring biased detent or some other similar attachment mechanism 520. Therefore, if a surgeon at a master handle actuates the grippers, the gripper motor 506 turns, thus laterally moving the rod 516, and in turn the center cable 350 which opens and closes the grippers at the tool accordingly. Of course, the action at the tool will depend upon the type of tool disposed thereat. For example, if a stapling tool is disposed at the end of the surgical instrument 300 then a stapling action would take place.

If a master handle 50 or 52 is turned about axes J6 or J7 then one of the two wrist motors 510, 508 corresponding to the required motion turns. Each of the motors 508, 510 are attached to a corresponding gear 522, 524. Each of the gears 522, 524 engage a corresponding slotted section 530, 532 of an associated hollow tube 526, 528 to turn the associated tube radially about its longitudinal axis. Each of the tubes 526, 528 include notched ends 534, 536 to engage the notched ends of corresponding hollow tubes of the coupler 600. It is to be appreciated that each of the hollow tubes 526, 528, 618 and 620 are all coaxial. Additionally, bearings may be emplaced intermediate each of the tubes 526 and 528 to provide easy independent rotatability of the individual tubes.

When the tubes 526, 528 are rotated, they rotate the tubes in the coupler which rotates the tubes in the translator. This results in the articulation at the tip of the surgical instrument 300. More particularly, this results in the articulation of the articulable portion of the surgical instrument 300. Additionally, whether the front loading tool driver, the back loading tool driver, or the articulable tool driver are employed, surgical instruments may be easily exchanged.

As such, a cutting blade 800 may be exchanged for a grasper, and a grasper may be exchanged for a stapler 810. Essentially, such a system simplifies the performance of minimally invasive surgical procedures where the procedures include the step of changing one tool for another. And because the system allows articulation at the tip of certain instruments, the articulation mechanism may be used to articulate such stapling, or cutting instruments that incorporate the articulable portion as disclosed hereinabove.

Additionally, the instrument may not be an articulable instrument, but the articulating mechanism can be used to control other functions, such as stapling. Figure 27 depicts a stapling instrument 810 attached to the robotic arm assembly via the collar 85 and holder 86. The lead that is generally use for the grasping tool, may be used to effectuate the stapling mechanism. Endoscopic staplers are generally well known in the art, however, it is heretofore to known to use a stapler that is attached to a robotic arm as is disclosed herein.

Additionally, a cutting blade, such as that depicted in Figure 28 may be employed in the system of the present invention. The cutting blade 800 is attached to the robotic arm assembly 26 via the collar 85 and holder 86. The cutting blade does not require a lead such as that required by the grasper or the

stapler; however, the cutting tool, may be articulated via the articulating mechanism that has been disclosed hereinabove.

A cauterizer or coagulator may additionally be attached to the robotic arm assembly 26 via the collar 85 and holder. Cauterizers and coagulators are well known and the cauterizing tool may be attached at the end of an articulable instrument as disclosed hereinabove. By using a variety of tools in predetermined sequences, various procedures may be carried out. It is generally preferable to be able to change instruments because many procedures require such.

While certain exemplary embodiments have been described and shown in the accompanying drawings, it is to be understood that such embodiments are merely illustrative of and not restrictive on the broad invention, and that this invention not be limited to the specific constructions and arrangements shown and described, since various other modifications may occur to those ordinarily skilled in the art.

What is claimed is:

1. A minimally invasive procedure for suturing a secondary vessel to a coronary artery of a patient with a suturing needle, wherein the coronary artery has an opening, comprising the steps of:

a) providing a first articulate arm and a second articulate arm, said first and second articulate arms being coupled to a controller and an input device that receive an input command and move said first and second articulate arms in response to the input command;

b) cutting at least one incision into the patient;

c) inserting said first and second articulate arms into the patient through the incision;

d) generating an input command to move said first articulate arm to grasp the secondary vessel;

e) generating an input command to move said second articulate arm to grasp the suturing needle;

f) generating an input command to move said second articulate arm to move the needle through the coronary artery and the secondary vessel; and

g) repeating step (g) to suture the secondary vessel to the coronary artery.

2. The method as recited in claim 1, wherein the secondary vessel is a internal mammary artery and the method further includes the step of cutting the internal mammary artery before moving the internal mammary artery to the location adjacent to the artery opening.

3. The method as recited in claim 1, further comprising the step of generating input commands to move said first articulate arm to move the needle and suture the secondary vessel to the coronary artery.

4. The method as recited in claim 1, wherein said steps of generating the input commands include a surgeon moving a first master handle and a second master handle such that the movement of said first and second articulate arms correspond to the movement of said first and second master handles.

5. The method as recited in claim 4, wherein said first and second articulate arms each have an end effector which move a scaled increment of the movement of said first and second master handles.

6. The method as recited in claim 4, further comprising the steps of activating said first and second articulate arms such that said first and second articulate arms move in conjunction with the movement of said first and second master handles and deactivating said first and second articulate arms so that said first and second articulate arms remain stationary when said first and second master handles are moved by the surgeon.

7. The method as recited in claim 1, further comprising the steps of providing an endoscope that is coupled to a third articulate arm and inserting the endoscope into the patient through an incision, wherein said third articulate arm is coupled to said controller and an endoscopic input device that receives an input command.

8. The method as recited in claim 7, further comprising the step of generating an input command that moves said third articulate arm and the endoscope within the patient.

9. The method as recited in claim 5, further comprising the step of applying a force to the surgeon which corresponds to a force applied by said end effector.

10. The method as recited in claim 9, wherein the force applied to the surgeon is a scaled increment of the force applied by said end effector.

11. The method as recited in claim 4, further comprising the step of filtering input commands that correspond to a hand tremor of the surgeon.

12. A system that allows a surgeon to perform a procedure on a patient, comprising:

a first articulate arm which has a first end effector;

a first input device that can be moved a first input device spatial increment by the surgeon to create a first input command; and,

a controller that is coupled to said first input device and said first articulate arm, said controller receives said first input command from said first input device and provides a first output command to said first articulate arm to move said first end effector a first end effector spatial increment, wherein said controller scales said first input command so that the first input device spatial increment is different than the first end effector spatial increment.

13. The system as recited in claim 12, further comprising a second articulate arm which has a second end effector, and a second input device which can be moved a second input device spatial increment by the surgeon to create a second input command, said controller receives said second input command from said

second input device and provides a second output command to said second articulate arm to move said second end effector a second end effector spatial increment, wherein said controller scales said second input command so that the second input device spatial increment is different than the second end effector spatial increment.

14. The system as recited in claim 13, further comprising a third articulate arm that holds an endoscope, and a third input device which receives an instruction from the surgeon and which generates a third input command in response to the instruction, said controller receives said third input command and provides a third output command to said third articulate arm to move the endoscope.

15. The system as recited in claim 12, wherein said first input device is a master handle that is moved by the surgeon, said input device further has an input button that is coupled to said controller to activate said first articulate arm so that said first end effector moves in conjunction with a movement of said master handle and deactivates said first articulate arm so that said first end effector remains stationary when said master handle is moved by the surgeon.

16. The system as recited in claim 15, wherein said master handle pivots about a master pivot point.

17. The system as recited in claim 12, wherein said first end effector has a force sensor and said first input device has an actuator that is coupled to said force sensor to apply a force to the surgeon that corresponds to a force sensed by said force sensor.

18. The system as recited in claim 17, wherein the force applied to the surgeon is a scaled increment of the force sensed by said force sensor.

19. The system as recited in claim 12, wherein said input device has a first position sensor that provides a first input position signal and a second position sensor that provides a second input position signal, wherein said controller provides a first scale factor for said first input position signal and a second scale factor for said second input position signal.

20. The system as recited in claim 12, wherein said first articulate arm includes a surgical instrument that is coupled to a robotic arm by a sterile coupler.

21. The system as recited in claim 20, wherein said robotic arm is enclosed by a sterile bag.

22. The system as recited in claim 12, wherein said first articulate arm rotates about a pivot point located at an incision of the patient.

23. The system as recited in claim 22, wherein said robotic arm has a pair of passive joints.

24. The system as recited in claim 12, wherein said controller has a filter that filters a first input command which corresponds to a hand tremor of the surgeon.

25. A medical robotic system that can be inserted through a first incision of a patient and controlled by a surgeon, comprising:

a first articulate arm which has a passive joint that is coupled to a first end effector inserted into

the incision, wherein the incision defines a first pivot point for said first end effector;

a first input device that creates a first input command in response to an instruction from the surgeon;
and,

a controller that is coupled to said first input device and said first articulate arm, said controller receives said first input command from said first input device and provides a first output command to said first articulate arm to move said first end effector relative to the first pivot point.

26. The system as recited in claim 25, further comprising a second articulate arm which has a second end effector, and a second input device which creates a second input command in response to an instruction from the surgeon, said controller receives said second input command from said second input device and provides a second output command to said second articulate arm to move said second end effector about a second pivot point located at a second incision of the patient.

27. The system as recited in claim 26, further comprising a third articulate arm that holds an endoscope, and a third input device which receives an instruction from the surgeon and which generates a third input command in response to the instruction, said controller receives said third input command and provides a third output command to said third articulate arm to move the endoscope about a third pivot point located at a third incision of the patient.

28. The system as recited in claim 27, wherein said first input device is a master handle that is moved by the surgeon.

29. The system as recited in claim 25, wherein said first input device is a master handle that is moved by the surgeon, said input device further has an input button that is coupled to said controller to activate said first articulate arm so that said first end effector moves in conjunction with a movement of said master handle and deactivates said first articulate arm so that said first end effector remains stationary when said master handle is moved by the surgeon.

30. The system as recited in claim 28, wherein said first end effector moves a scaled increment of a movement of said master handle.

31. The system as recited in claim 25, wherein said first end effector has a force sensor and said first input device has an actuator that is coupled to said force sensor to apply a force to the surgeon that corresponds to a force sensed by said force sensor.

32. The system as recited in claim 31, wherein the force applied to the surgeon is a scaled increment of the force sensed by said force sensor.

33. The system as recited in claim 25, wherein said first articulate arm includes a surgical instrument that is coupled to a robotic arm by a sterile coupler.

34. The system as recited in claim 33, wherein said robotic arm is enclosed by a sterile bag.

35. The system as recited in claim 25, wherein said robotic arm has a pair of passive joints.

36. The system as recited in claim 25, wherein said controller has a filter that filters a first input

command which corresponds to a hand tremor of the surgeon.

37. A system that allows a surgeon to perform a procedure on a patient, comprising:

a first articulate arm which has a first end effector;

a first input device that can be moved a first input device spatial increment by the surgeon to create a first input command;

a controller that is coupled to said first input device and said first articulate arm, said controller receives said first input command from said first input device and provides a first output command to said first articulate arm to move said first end effector; and,

a second input device that activates said first articulate arm so that said first end effector moves in conjunction with said first input device and deactivates said first articulate arm so that said first end effector remains stationary while the surgeon moves said first input device.

38. The system as recited in claim 37, further comprising a second articulate arm which has a second end effector and a second input device which can be moved a second input device spatial increment by the surgeon to create a second input command, said second input device has a second input button that can be depressed by the surgeon, said controller receives said second input command from said second input device and provides a second output command to said second articulate arm to move said second end effector when said second input button is depressed.

39. The system as recited in claim 38, further comprising a third articulate arm that holds an

endoscope, and a third input device which receives an instruction from the surgeon and which generates a third input command in response to the instruction, said controller receives said third input command and provides a third output command to said third articulate arm to move the endoscope.

40. The system as recited in claim 37, wherein said first input device include a master handle that pivots about a master pivot point.

41. The system as recited in claim 40, wherein said first input device is a master handle that is moved by the surgeon, said input device further has an input button that is coupled to said controller to activate said first articulate arm so that said first end effector moves in conjunction with a movement of said master handle and deactivates said first articulate arm so that said first end effector remains stationary when said master handle is moved by the surgeon.

42. The system as recited in claim 37, wherein said first end effector has a force sensor and said first input device has an actuator that is coupled to said force sensor to apply a force to the surgeon that corresponds to a force sensed by said force sensor.

43. The system as recited in claim 42, wherein the force applied to the surgeon is a scaled increment of the force sensed by said force sensor.

44. The system as recited in claim 40, wherein said first end of effector moves a scaled increment of a movement of said master handle.

45. The system as recited in claim 37, wherein said first articulate arm includes a surgical instrument that is coupled to a robotic arm by a sterile coupler.

46. The system as recited in claim 45, wherein said robotic arm is enclosed by a sterile bag.

47. The system as recited in claim 37, wherein said first articulate arm rotates about a pivot point located at an incision of the patient.

48. The system as recited in claim 47, wherein said robotic arm has a pair of passive joints.

49. The system as recited in claim 37, wherein said controller has a filter that filters a first input command which corresponds to a hand tremor of the surgeon.

50. A medical robotic system, comprising:
a robotic arm;
a sterile bag that encloses said robotic arm;
a sterile coupler that is plugged into said robotic arm; and,
a surgical instrument that is plugged into said sterile coupler.

51. The system as recited in claim 50, wherein said surgical instrument is an end effector which has a pair of fingers.

52. The system as recited in claim 51, wherein said sterile coupler includes a piston that couples said end effector fingers to an actuator within said robotic arm.

53. A medical robotic system, comprising:
a robotic arm;
a coupler that pivotally attaches to the arm;
an endoscopic surgical instrument that is held
by said coupler; and
a controller having a handle, the controller
in electrical communication with the robotic arm; and
wherein movement at the controller produces a
proportional movement of the robotic arm and surgical
instrument.

54. The system of Claim 53 wherein said coupler
removably attaches to said robotic arm.

55. The system of Claim 53 wherein said endoscopic
surgical instrument is an articulable endoscopic
surgical instrument.

56. The system of Claim 53 wherein the articulable
surgical instrument comprises a base, a pivot linkage,
and a distal end.

57. The system of Claim 56 wherein a movement at
the controller results in corresponding movement of the
distal end of the articulable surgical instrument
relative to the base of the articulable surgical
instrument.

58. The system of claim 53 wherein the coupler has
an aperture formed therethrough.

59. A method for operating a surgical robotic
system for performing a surgical procedure on a patient,
the method comprising:

1) providing a first articulate arm, a
controller and an input device which receives input

commands, the first articulate arm in electrical communication with the controller and the controller in electrical communication with the input device;

2) cutting at least one incision into the patient;

3) attaching a surgical instrument to the first articulate arm;

4) inserting said surgical instrument into the patient through the at least one incision;

5) generating input commands to move said surgical instrument in accordance with the procedure being performed wherein said robotic arm moves said surgical instrument in accordance with the input commands; and

6) removing the surgical instrument from the patient.

60. The method of Claim 59 wherein after removing the surgical instrument from the patient further comprises the steps of:

1) replacing the surgical instrument with a different surgical instrument;

2) inserting said different surgical instrument into the patient;

3) generating input commands to move the different surgical instrument in accordance with the procedure being performed wherein said robotic arm moves the different surgical instrument in accordance with the input commands; and

4) removing the different surgical instrument from the patient.

61. The method of claim 59 wherein said surgical instrument is a grasper.

62. The method of Claim 59 wherein the surgical instrument is a stapler.

63. The method of Claim 59 wherein the surgical instrument is a cauterizer.

64. The method of Claim 59 wherein the surgical instrument is a cutting blade.

65. The system of Claim 57 wherein the tool attached at the distal end of the articulable surgical instrument is a stapler.

66. The system of Claim 57 wherein the tool attached at the distal end of the articulable surgical instrument is a cauterizer.

67. The method of Claim 59 wherein the step of attaching a surgical instrument to the collar by passing the instrument tip through the collar.

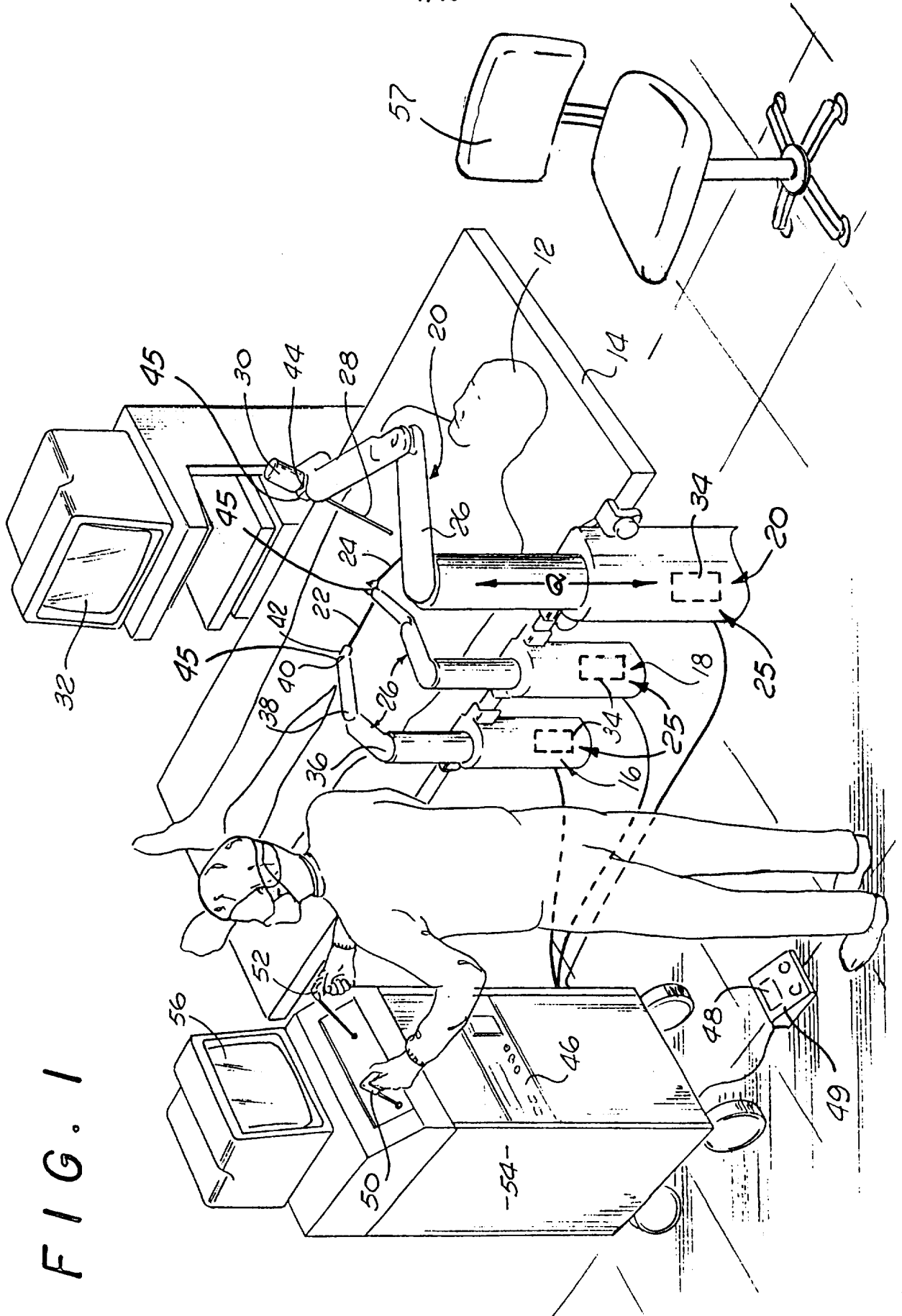

FIG. 1

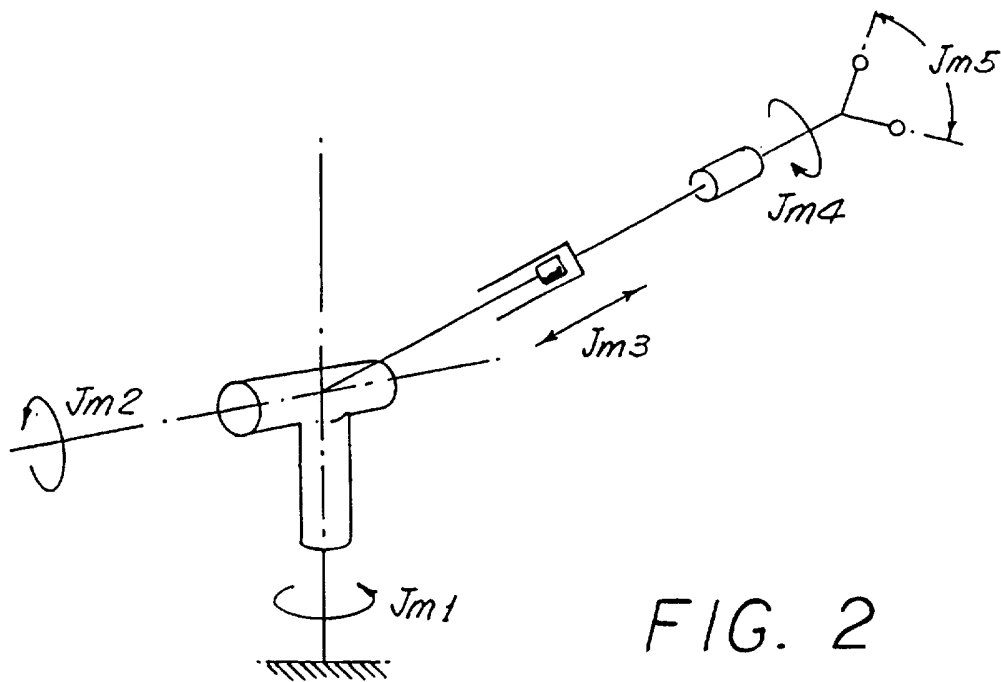

FIG. 2

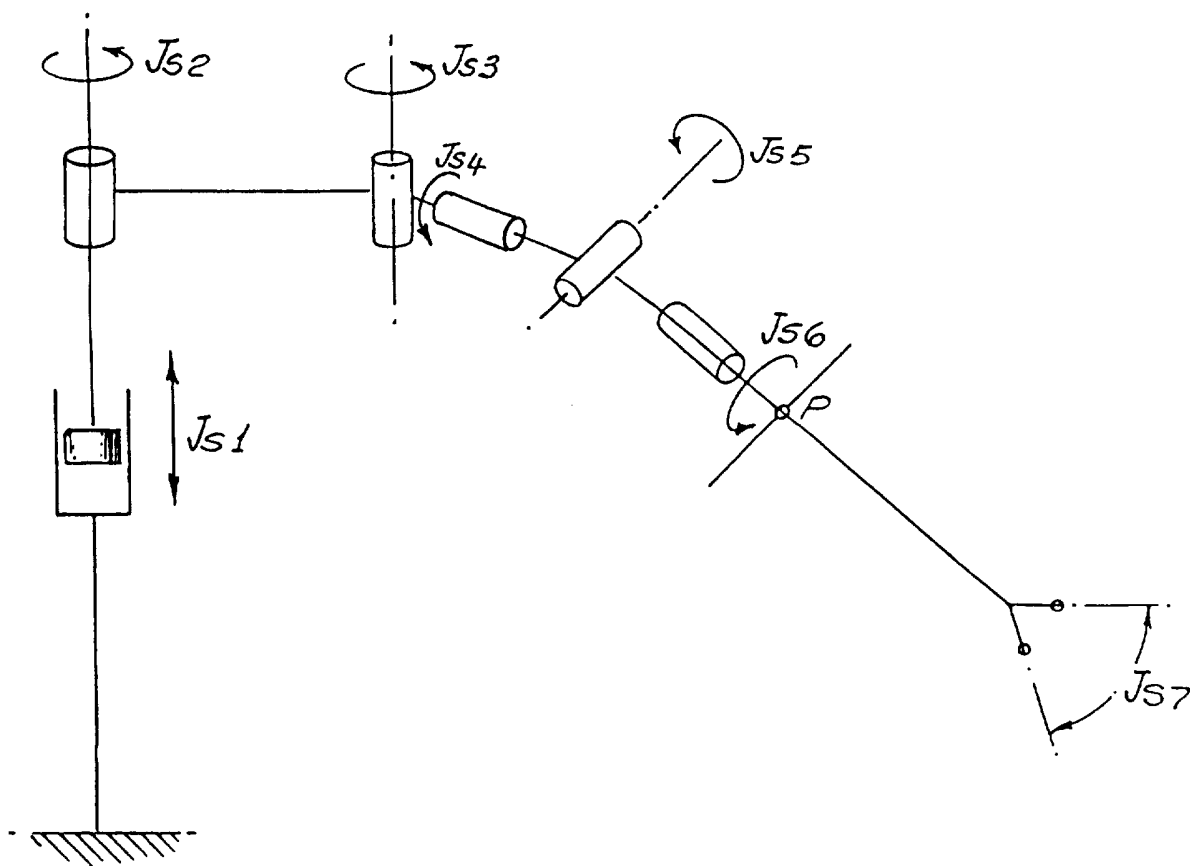

FIG. 3

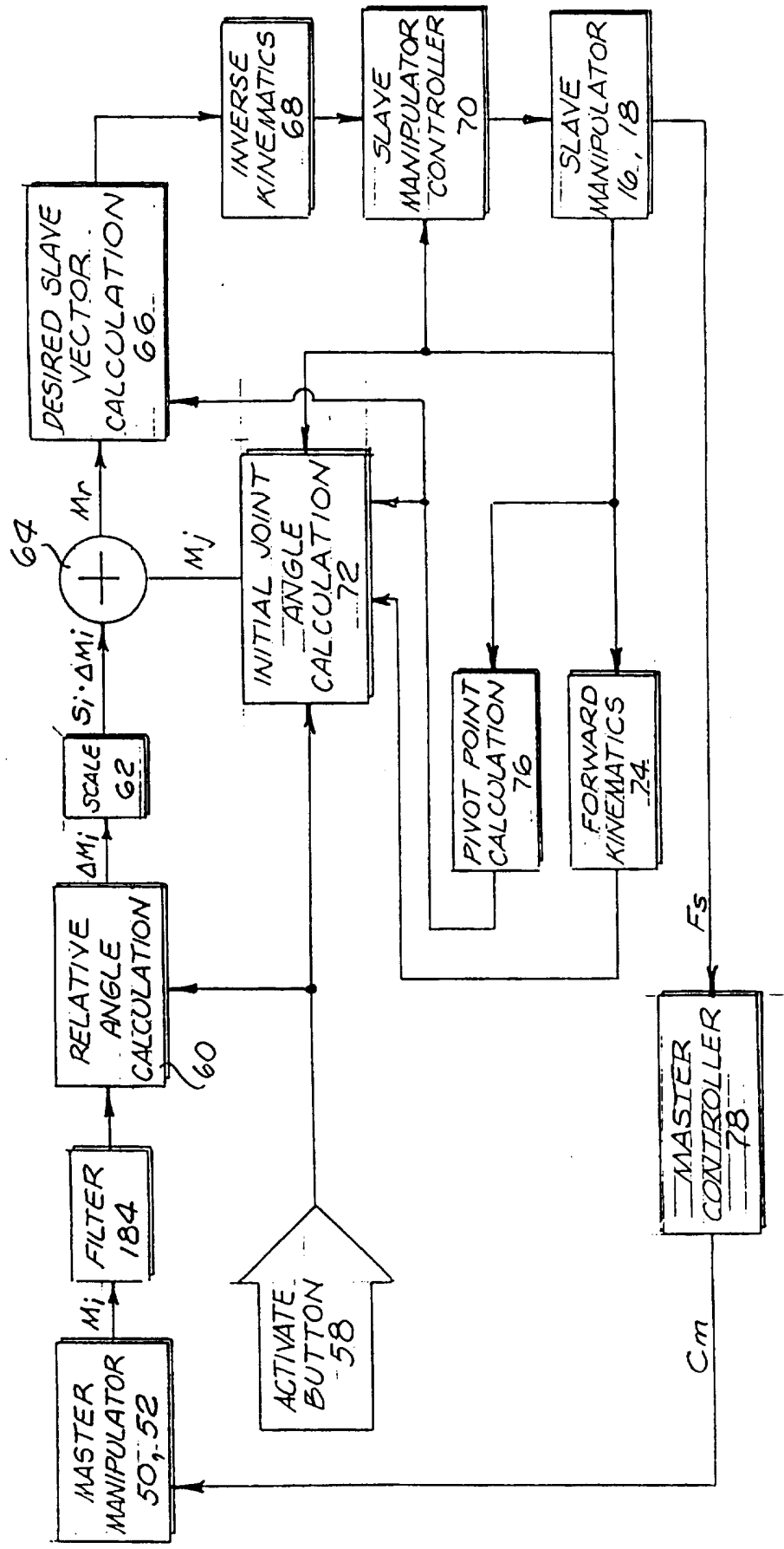

FIG. 4

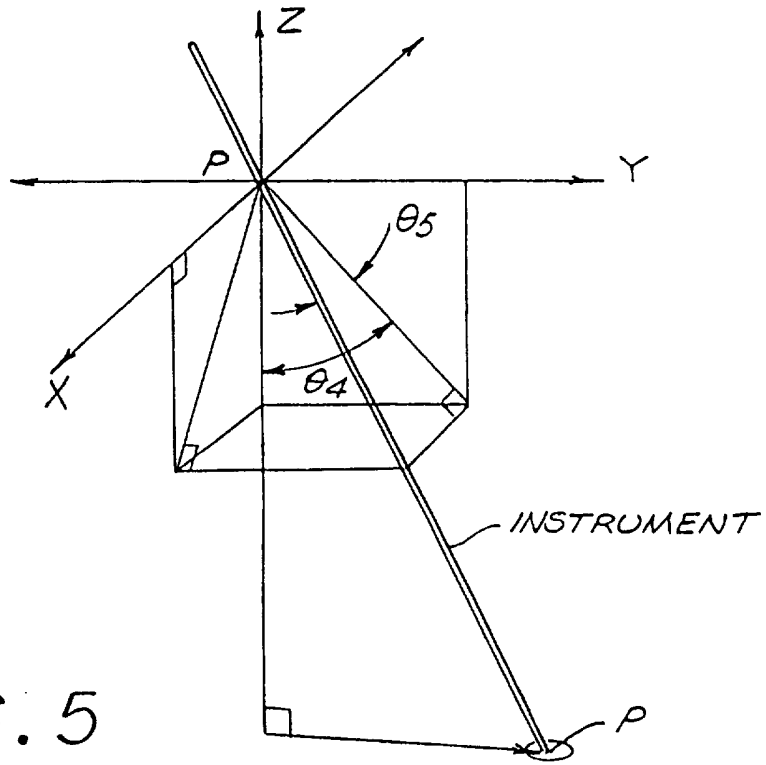

FIG. 5

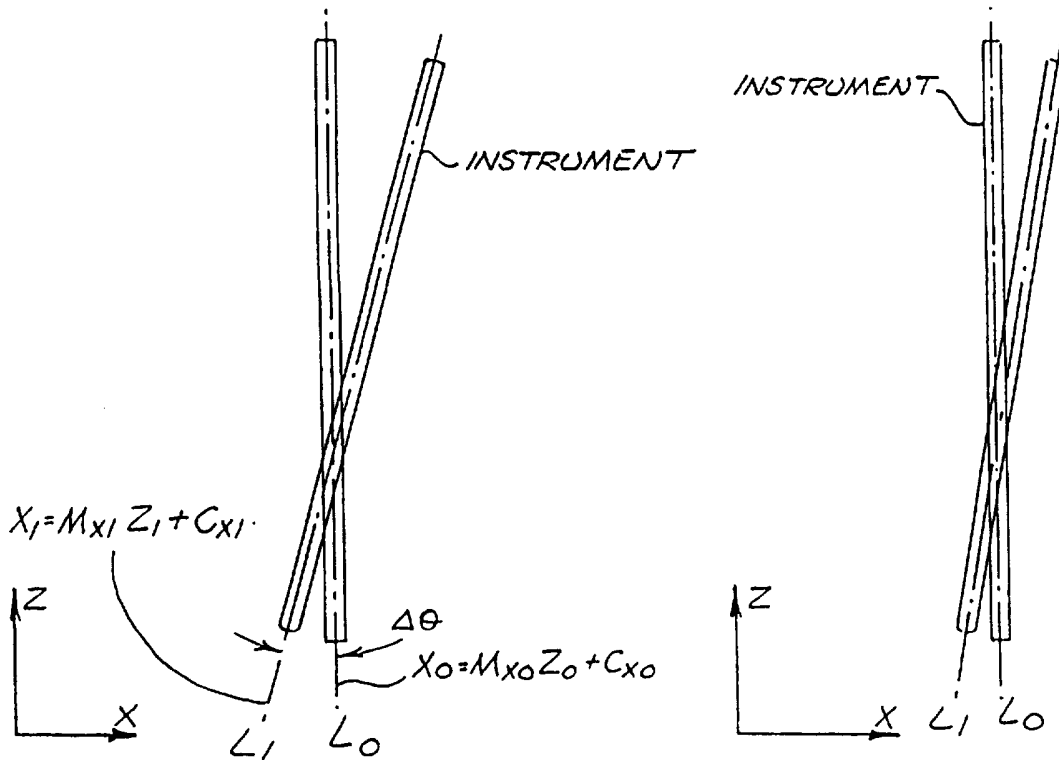

FIG. 6

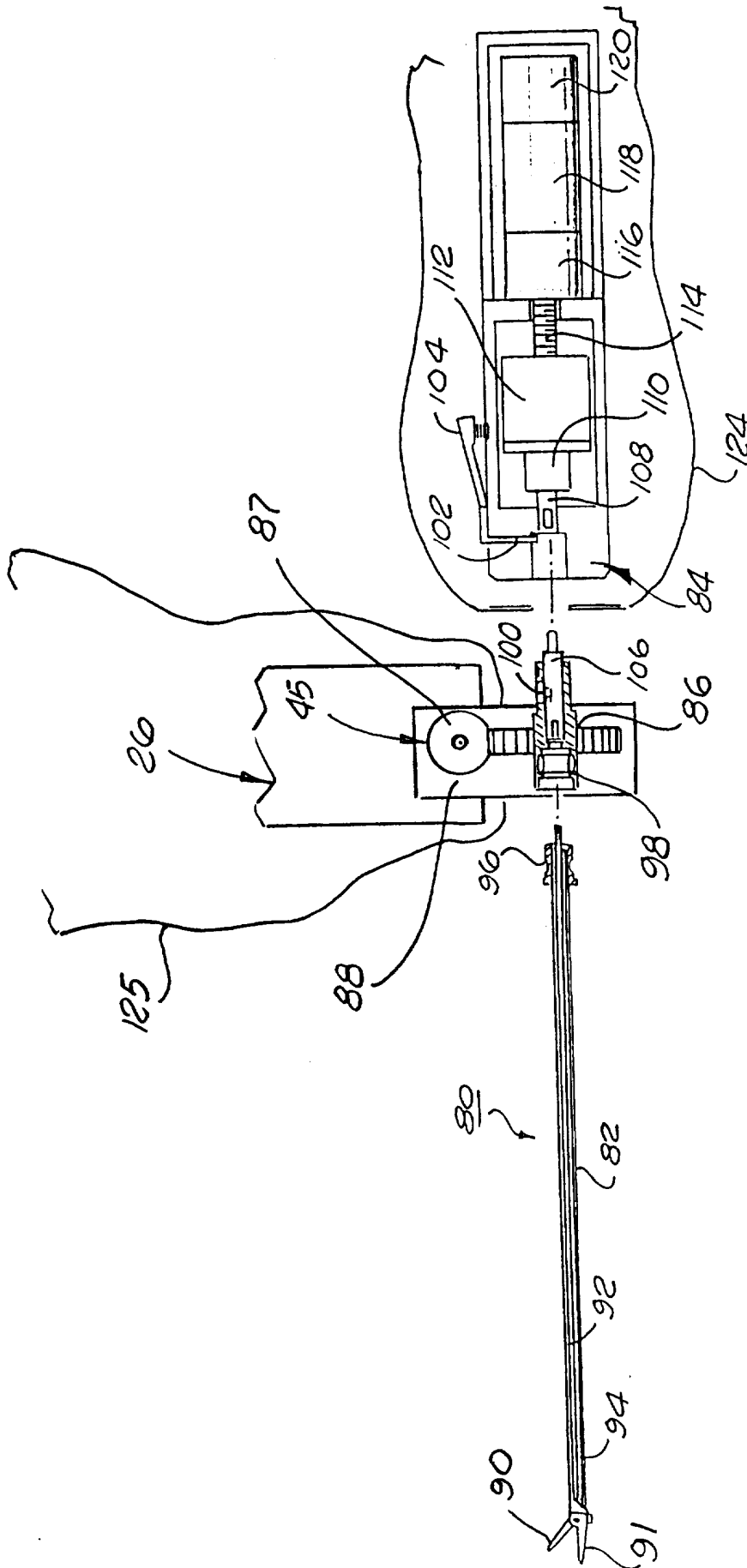

FIG. 7

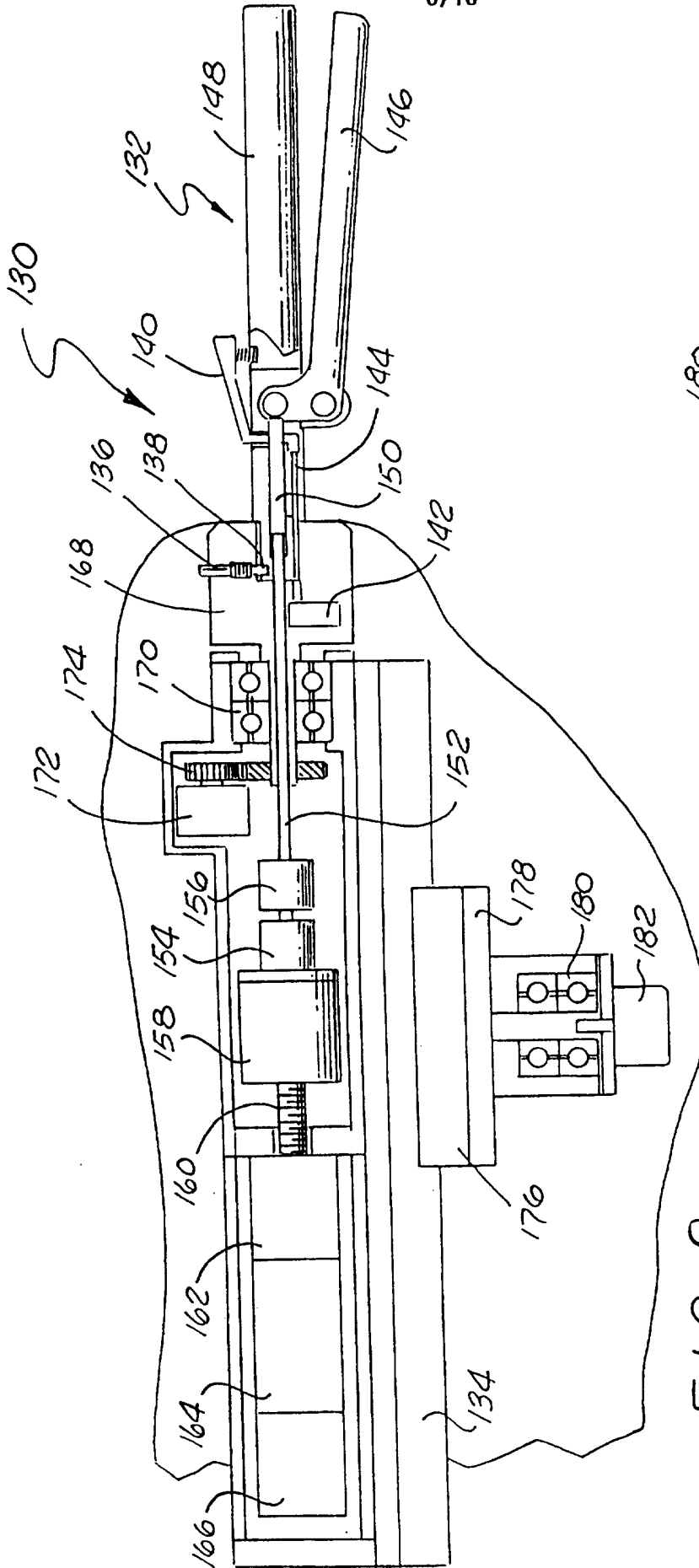

FIG. 8

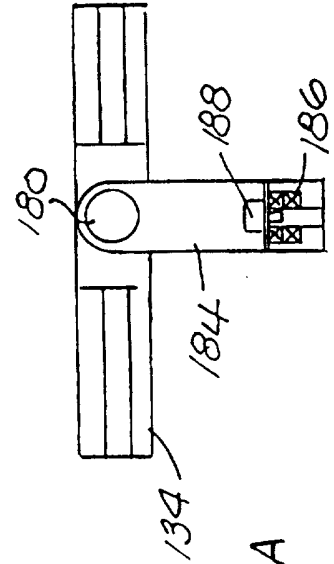

FIG. 8A

FIG. 9

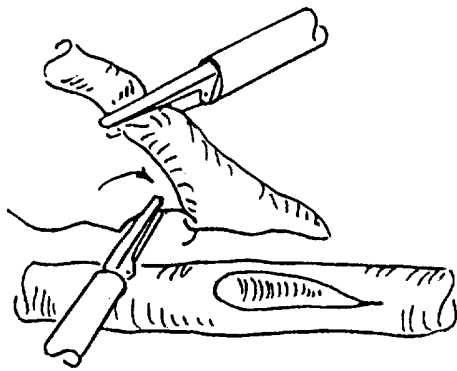
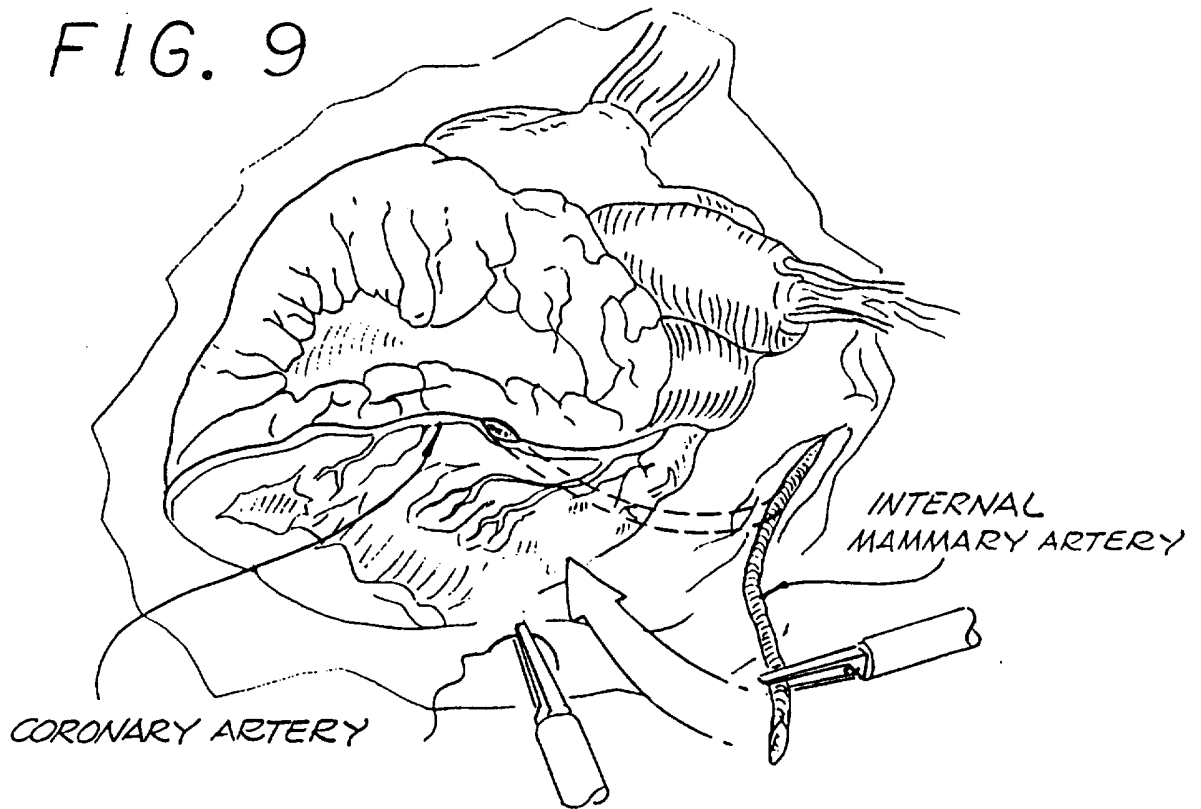

FIG. 10A

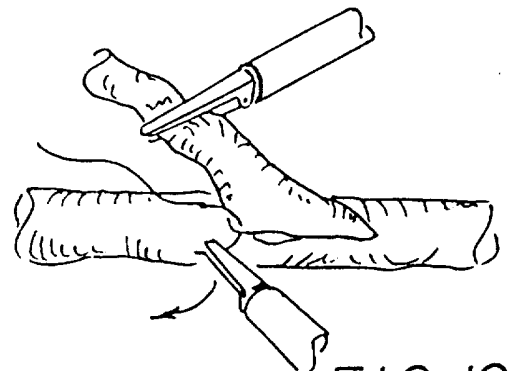

FIG. 10B

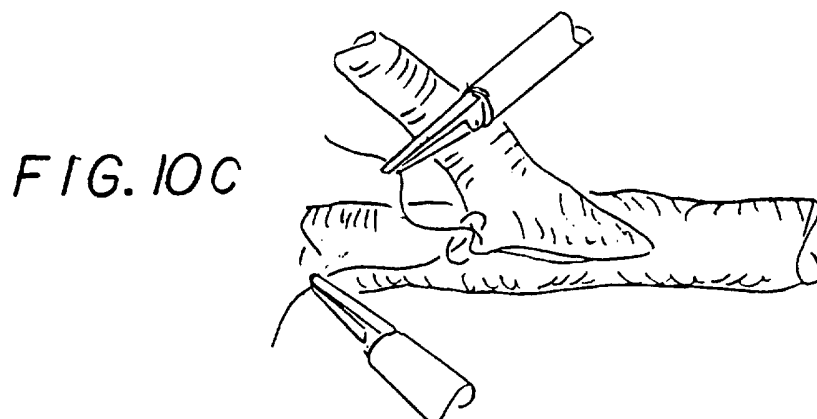

FIG. 10C

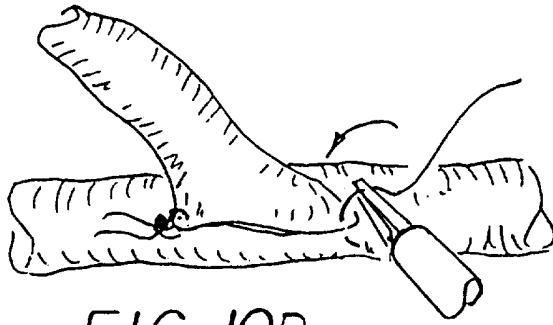

FIG. 10D

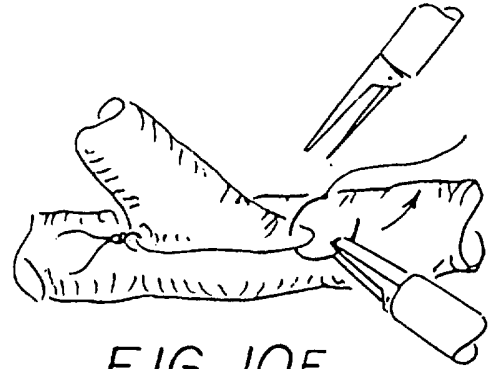

FIG. 10E

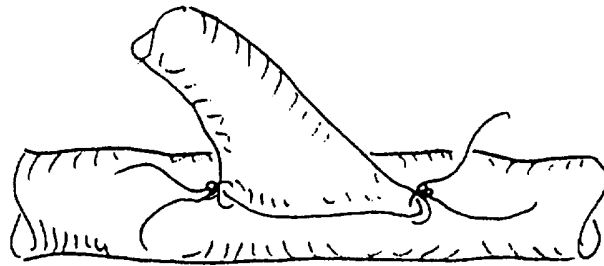

FIG. 10F

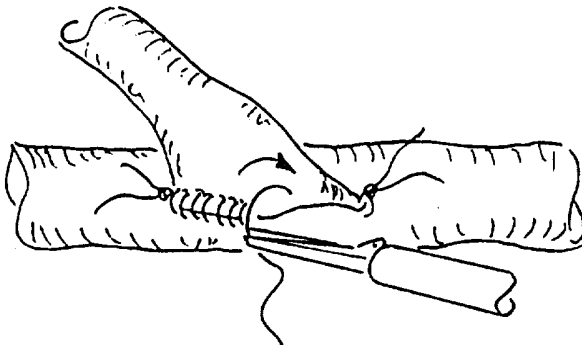

FIG. 10G

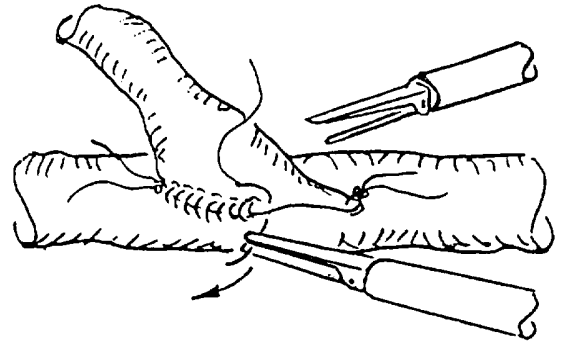

FIG. 10H

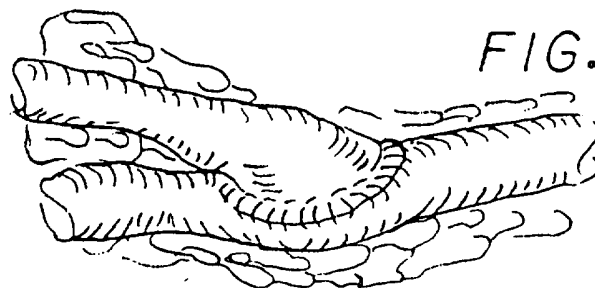

FIG. 10I

FIG. 11

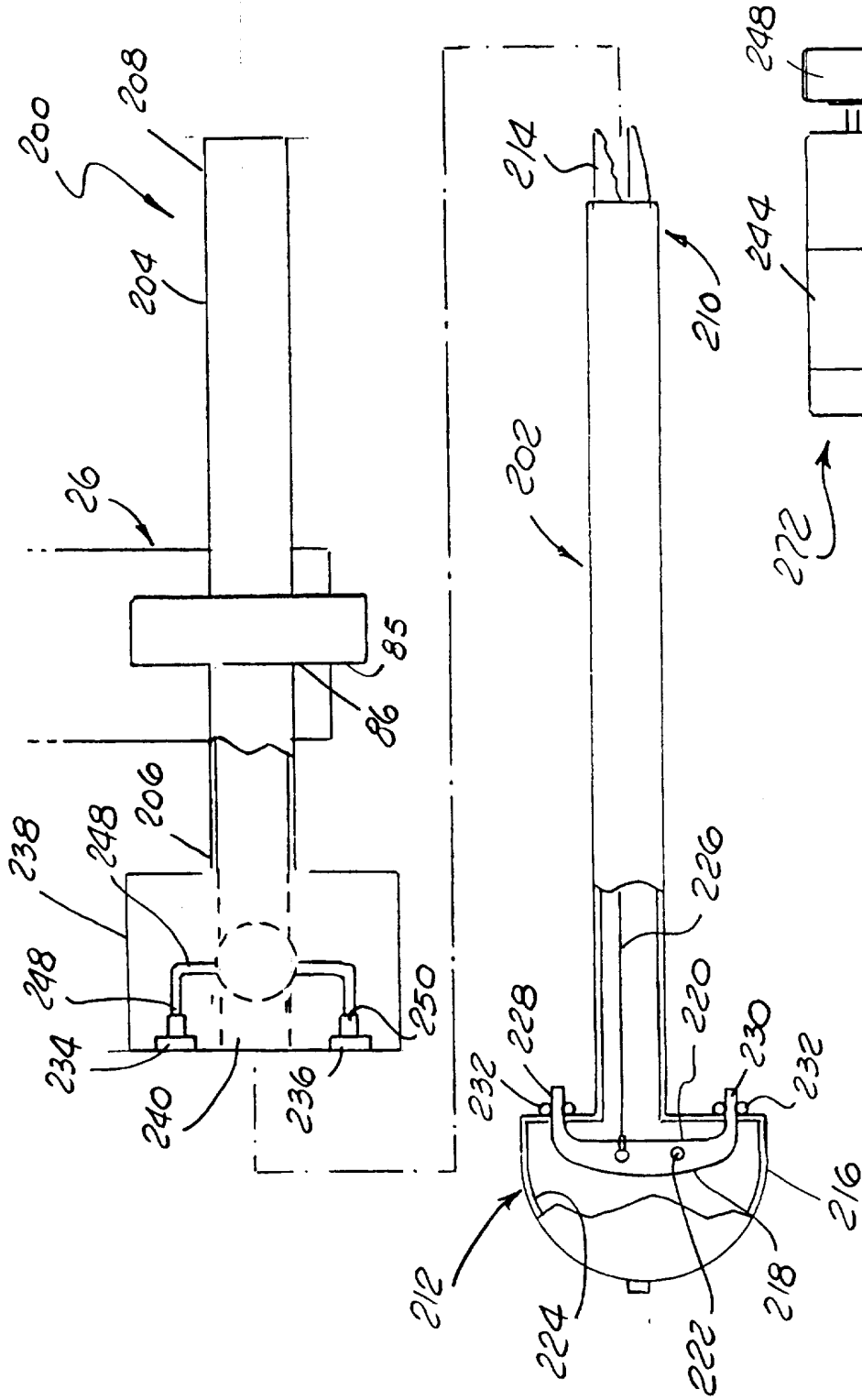

FIG. 12

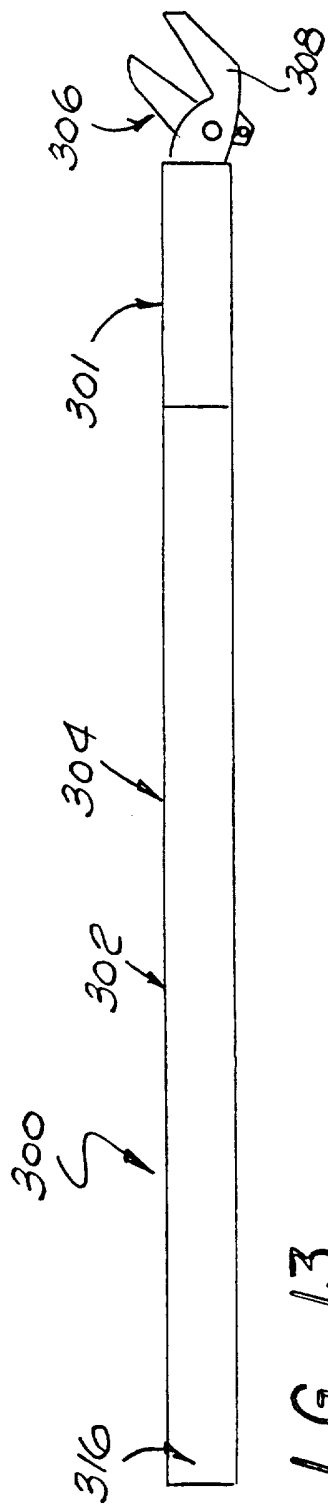

FIG. 13

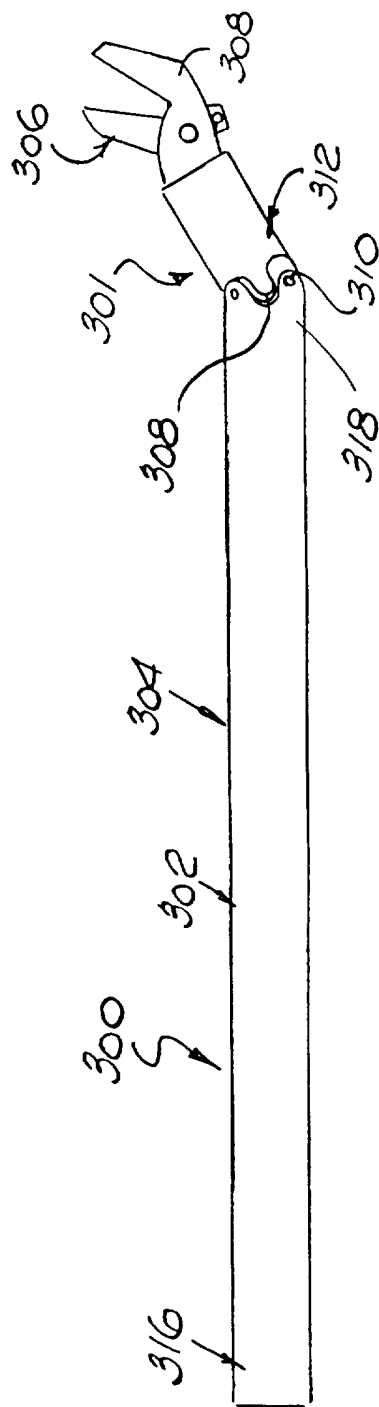

FIG. 14

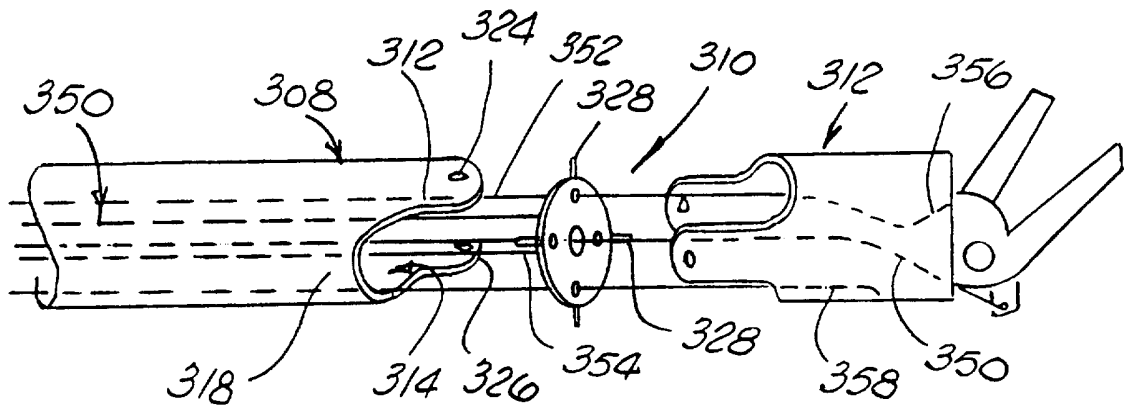

FIG. 15

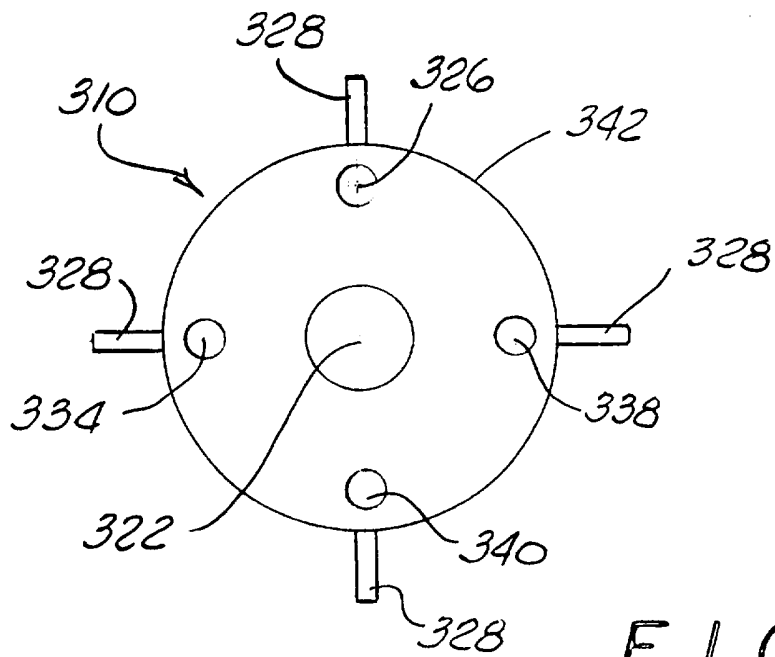
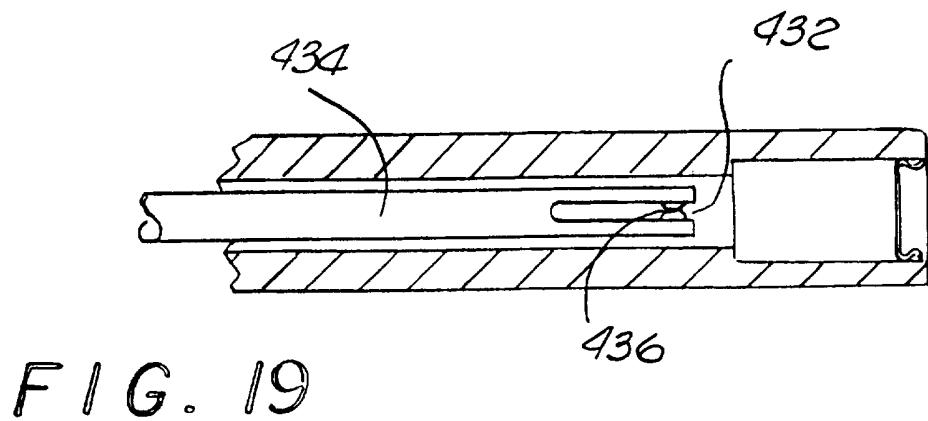
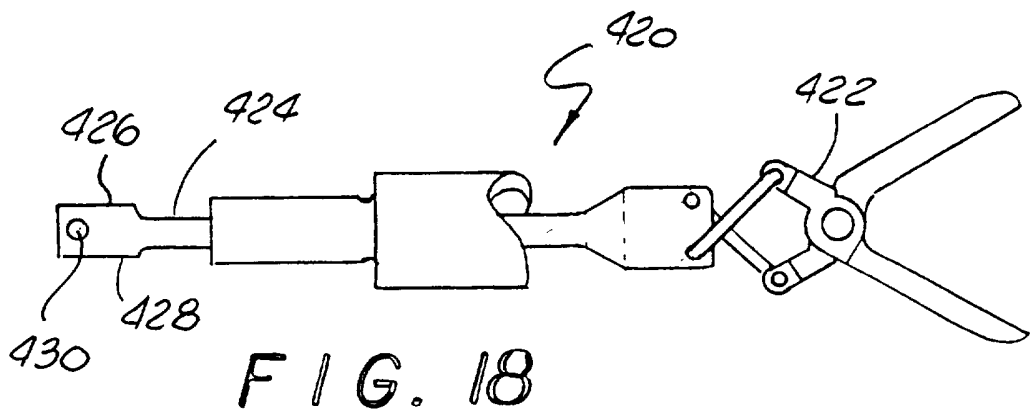
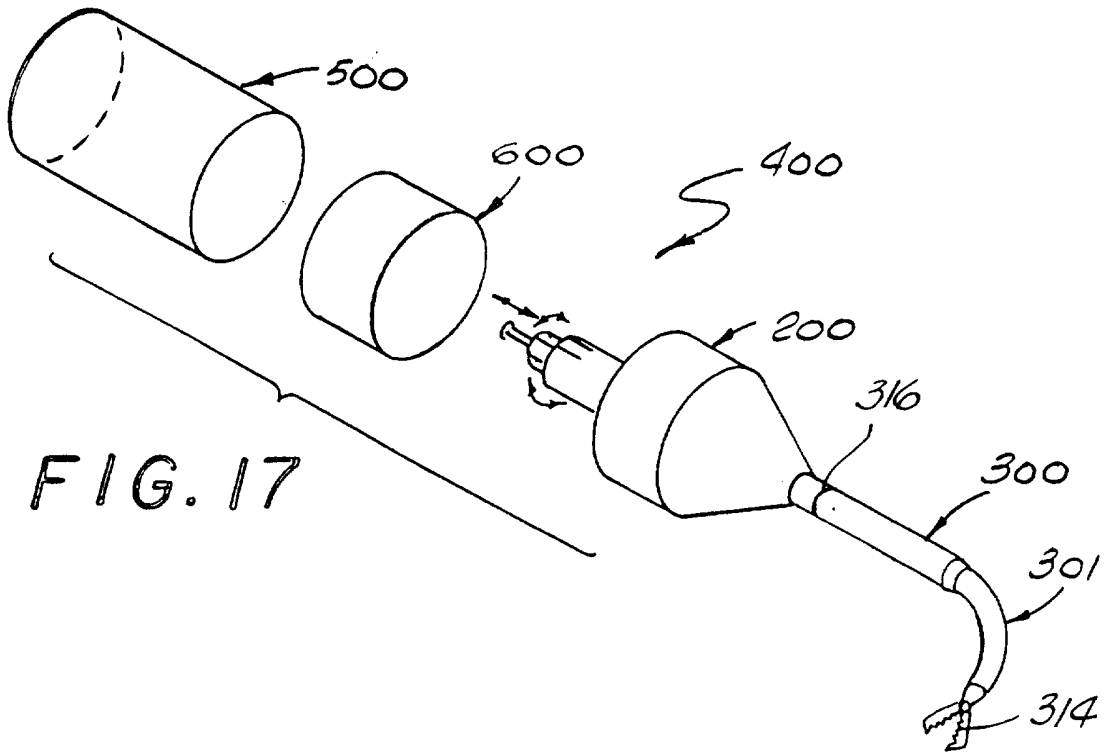

FIG. 16



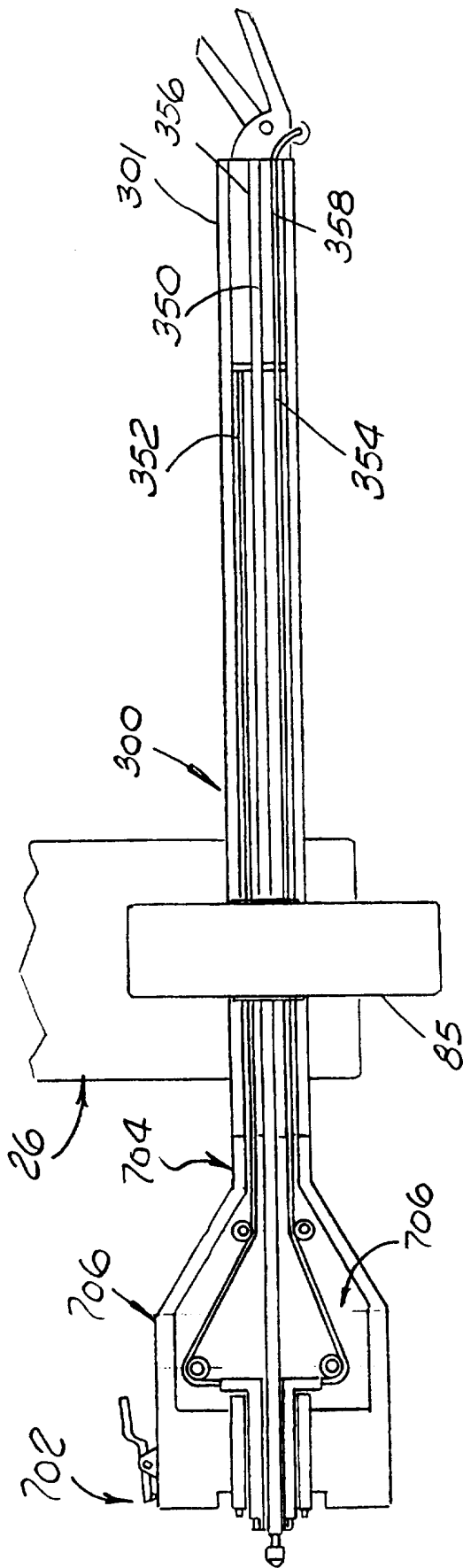

FIG. 20

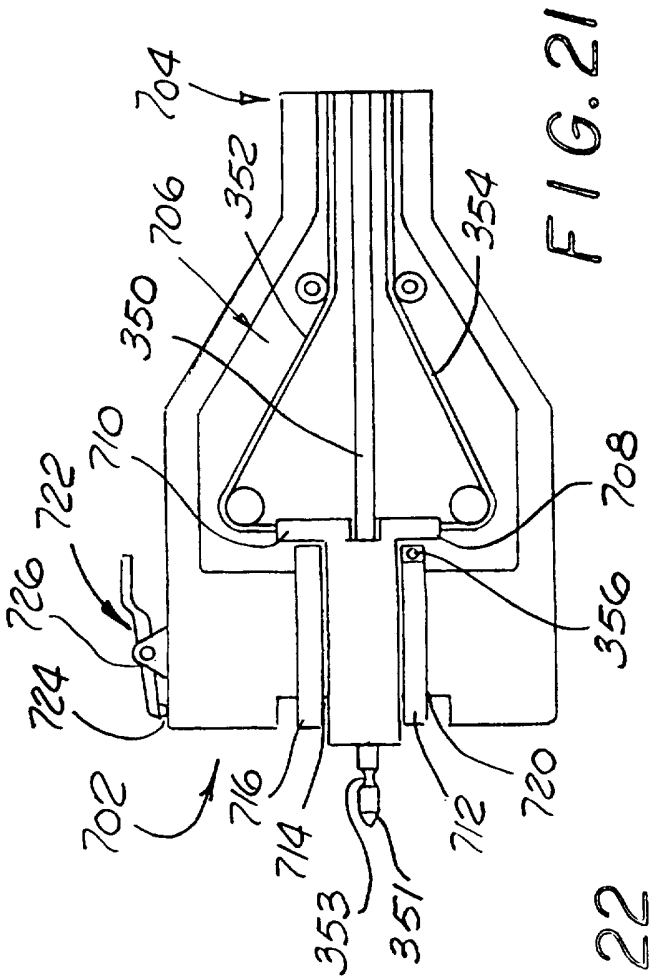

FIG. 21

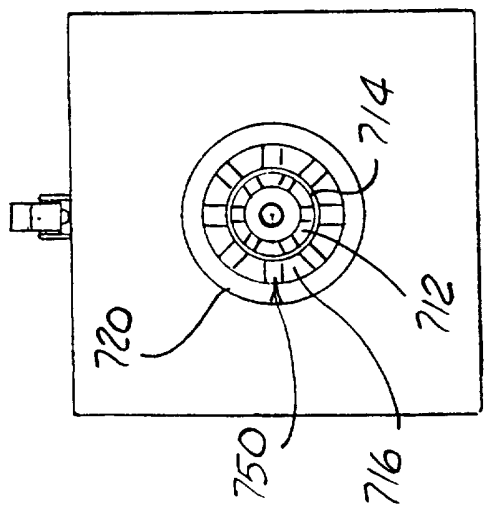

FIG. 22

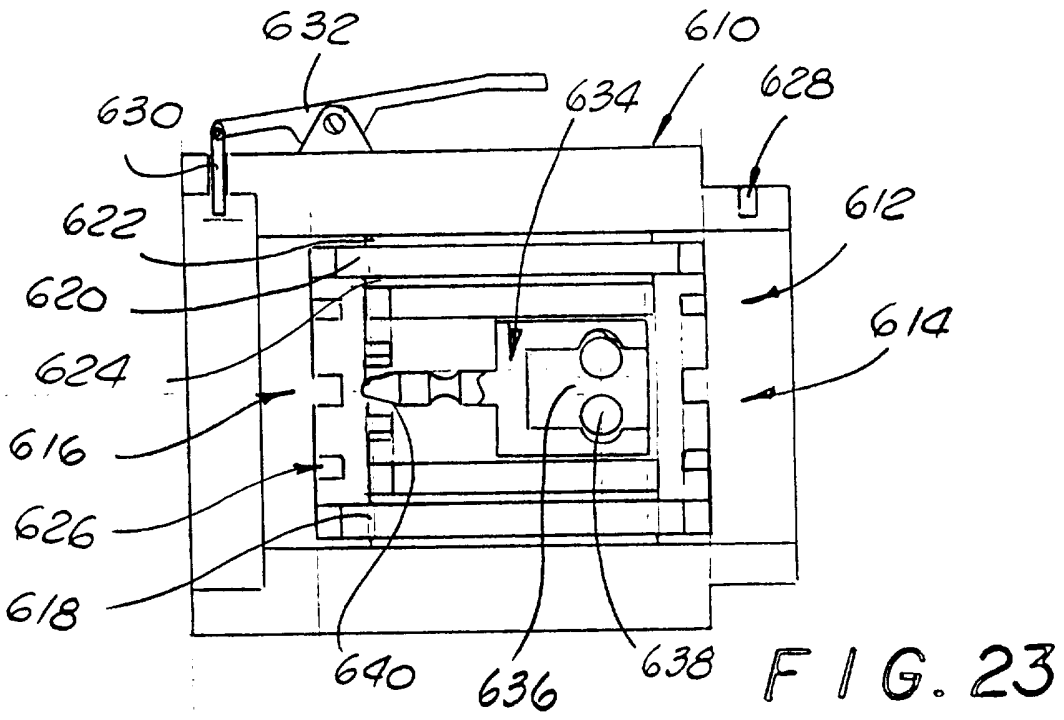
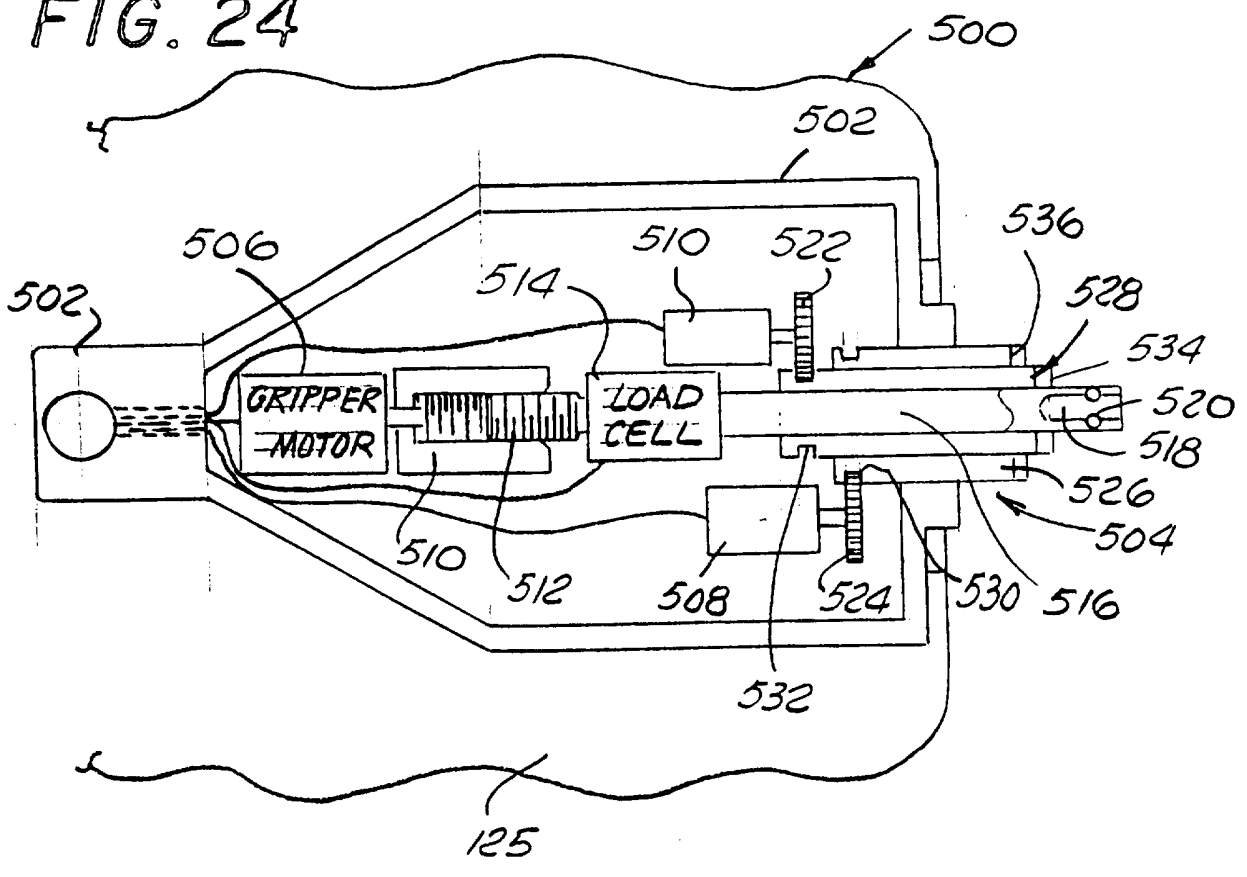

FIG. 24



15/16

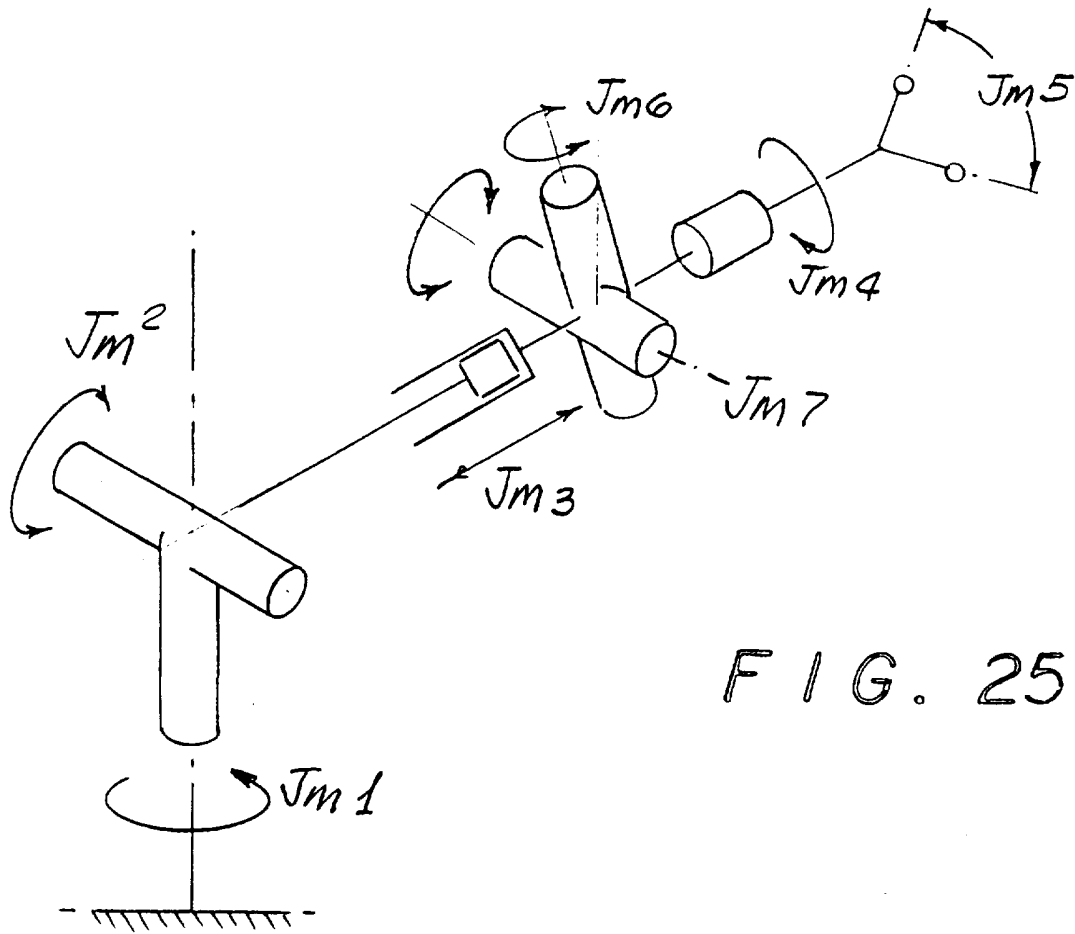

FIG. 25

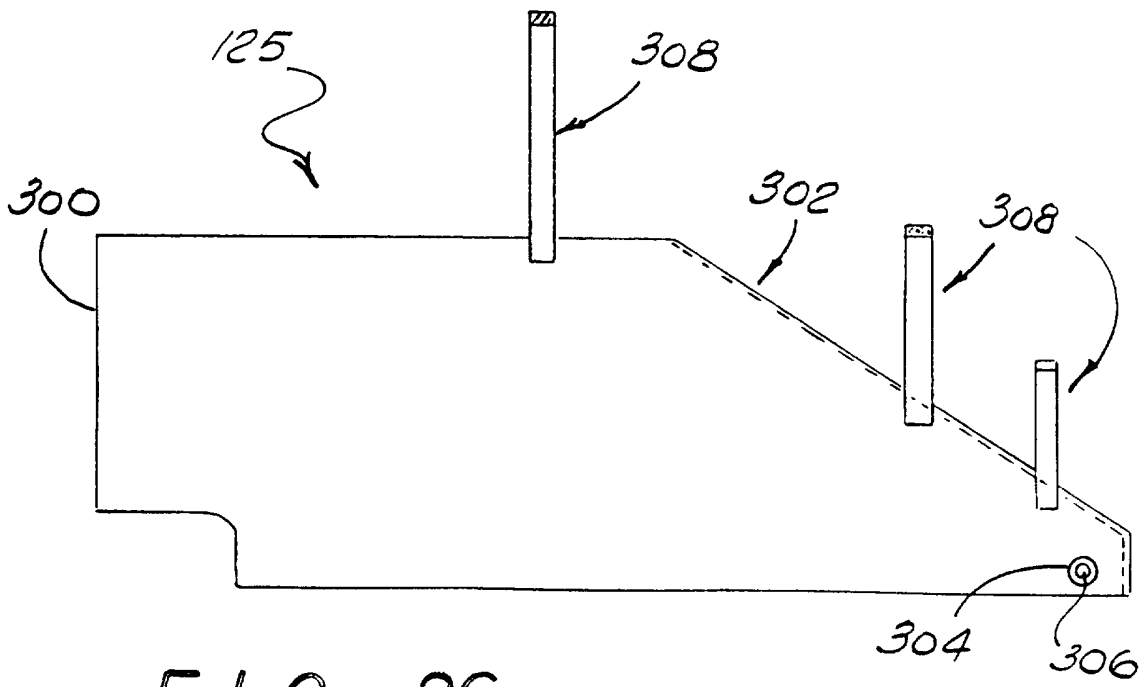

FIG. 26

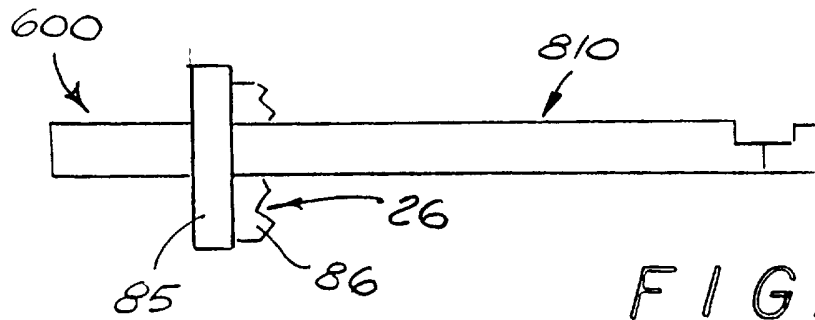

FIG. 27

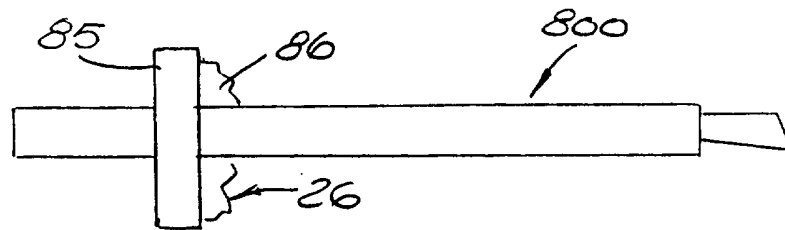

FIG. 28

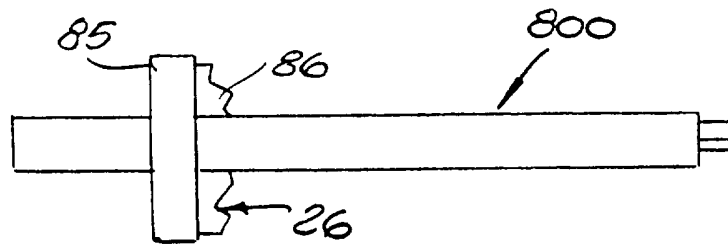

FIG. 29

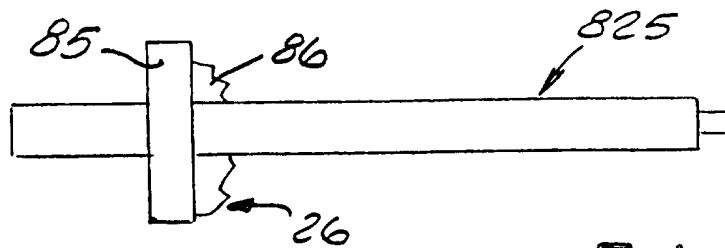

FIG. 30

INTERNATIONAL SEARCH REPORT

International application No.
PCT/US97/02628

A. CLASSIFICATION OF SUBJECT MATTER

IPC(6) : A61B 17/00
US CL : 128/898

According to International Patent Classification (IPC) or to both national classification and IPC

B. FIELDS SEARCHED

Minimum documentation searched (classification system followed by classification symbols)

U.S. : 128/898

Documentation searched other than minimum documentation to the extent that such documents are included in the fields searched

Electronic data base consulted during the international search (name of data base and, where practicable, search terms used)

C. DOCUMENTS CONSIDERED TO BE RELEVANT

| Category* | Citation of document, with indication, where appropriate, of the relevant passages | Relevant to claim No. |
|-----------|---|-----------------------|
| A | US 4,954,952 A (UBHAYAKAR et al) 04 September 1990, Abstract. | 1-11, 59-67 |
| A | US 4,980,626 A (HESS et al) 25 December 1990, col. 2, lines 51-69; and col. 3, lines 1-36 | 1-11, 59-67 |
| A | US 4,837,734 A (ICHIKAWA et al) 06 June 1989, entire document. | 1-11, 59-67 |
| A | US 4,367,998 A (CAUSER) 11 January 1983, col. 1, lines 1-51. | 1-11, 59-67 |

Further documents are listed in the continuation of Box C. See patent family annex.

| | |
|--|---|
| <p>* Special categories of cited documents:</p> <p>*A* document defining the general state of the art which is not considered to be of particular relevance</p> <p>*E* earlier document published on or after the international filing date</p> <p>*L* document which may throw doubts on priority claim(s) or which is cited to establish the publication date of another citation or other special reason (as specified)</p> <p>*O* document referring to an oral disclosure, use, exhibition or other means</p> <p>*P* document published prior to the international filing date but later than the priority date claimed</p> | <p>*T* later document published after the international filing date or priority date and not in conflict with the application but cited to understand the principle or theory underlying the invention</p> <p>*X* document of particular relevance; the claimed invention cannot be considered novel or cannot be considered to involve an inventive step when the document is taken alone</p> <p>*Y* document of particular relevance; the claimed invention cannot be considered to involve an inventive step when the document is combined with one or more other such documents, such combination being obvious to a person skilled in the art</p> <p>*G* document member of the same patent family</p> |
|--|---|

| | |
|--|--|
| <p>Date of the actual completion of the international search</p> <p style="text-align: center;">05 JUNE 1997</p> | <p>Date of mailing of the international search report</p> <p style="text-align: center;">03 JUL 1997</p> |
| <p>Name and mailing address of the ISA/US Commissioner of Patents and Trademarks Box PCT Washington, D.C. 20231 Facsimile No. (703) 305-3230</p> | <p>Authorized officer <i>Diane Smith for</i> GARY JACKSON Telephone No. (703) 308-4302</p> |