

J. W. Sawyer,
Binder.

No. 106,730.

Patented Aug. 23, 1870.

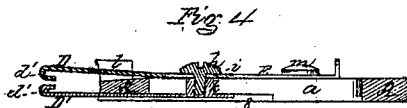
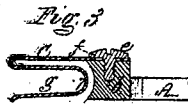
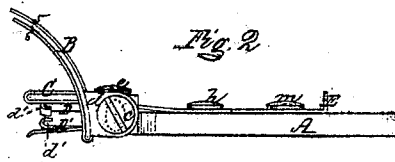
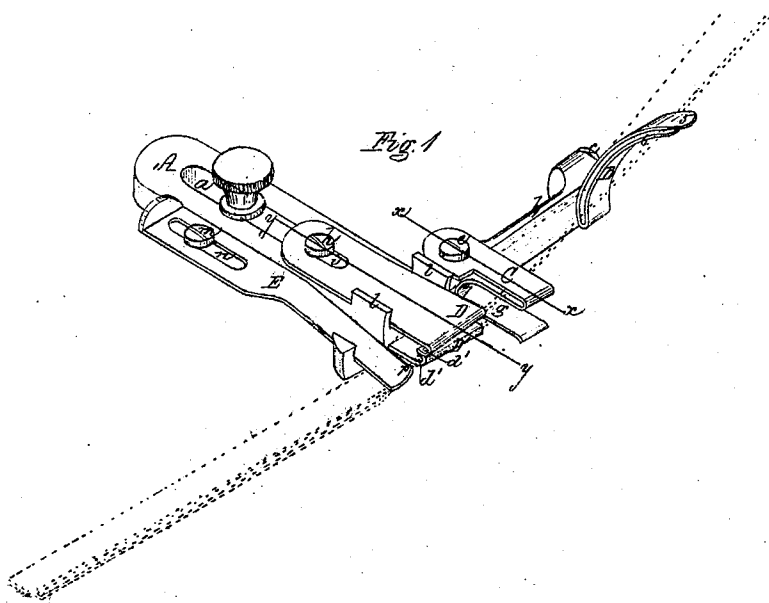

Witnesses,
W. A. Lambidge
L. C. Patcheller.

Inventor,
Joseph W. Sawyer

UNITED STATES PATENT OFFICE.

JOSEPH W. SAWYER, OF BOSTON, ASSIGNOR TO F. DRAPER & CO., OF CAMBRIDGE, MASSACHUSETTS.

IMPROVEMENT IN BINDING ATTACHMENTS FOR SEWING-MACHINES.

Specification forming part of Letters Patent No. 106,730, dated August 23, 1870.

To all whom it may concern:

Be it known that I, JOSEPH W. SAWYER, of Boston, in the county of Suffolk and State of Massachusetts, have invented an Improved Binding Attachment for Sewing-Machines, of which the following is a full, clear, and exact description, reference being had to the accompanying drawings, making part of this specification, in which—

Figure 1 is a perspective view of my improved binding attachment. Fig. 2 is an elevation of one end of the same. Fig. 3 is a section on the line *xx* of Fig. 1. Fig. 4 is a section on the line *yy* of Fig. 1.

My invention has for its object to provide a binding attachment for sewing-machines which will automatically guide a binding of any width without requiring the use of the hands, and which will also effectually prevent the binding from being thrown out of the jaws which hold the edge of the cloth or fabric being bound; and my invention consists in the combination of an adjustable guide and an adjustable folder of peculiar construction with the jaws which hold the fabric being bound, the guide and folder serving to remove any twists in the binding and cause it to run evenly and straight to the jaws, so that the work will be performed in a superior manner.

To enable others skilled in the art to understand and use my invention, I will proceed to describe the manner in which I have it carried out.

In the said drawings, A is the frame or stock of the binder, which is provided with a slot, *a*, so that it can be attached to the top plate of a sewing-machine by means of the ordinary gage-screw. Projecting from one side of the frame A, and formed in one and the same piece therewith, is an arm, *b*, the front face of which is concave or grooved, as seen in Fig. 1.

B is a curved guide formed of a strip of spring metal bent double into the shape seen in Figs. 1 and 2, so as to admit the tape or binding at the top, the two portions 5 6 yielding to accommodate bindings of various thicknesses. The guide B is secured to the outer extremity of the arm *b* by a screw, *c*, which passes through a slotted projection, *d*.

The folder C, which is secured to the arm *b* by means of a screw, *e*, passing through a slot,

f, is formed of a single piece of spring metal, and is shaped as shown, so as to fold the binding and guide it evenly to the spring-jaws D D', the ends of which are turned, as seen at *d'*, so as to form guides to receive and hold the edges of the binding, the upper jaw, D, being inclined, so that it will receive the binding more directly as it comes from the folder and with less friction and more evenly than would be the case were both jaws parallel to each other. The center of the binding is held up at all times against the concave face of the arm *b* by the portion 7 of the folder, which is made adjustable for different thicknesses of binding by means of the slot *f* and screw *e*. The space *g* within the folder is for the reception of the edge of the cloth to be bound, which is held firmly by the jaws D D', which, being made of spring metal, press the binding firmly upon the edge of the cloth without regard to its thickness.

The guide B and folder C used together not only serve to guide the binding evenly and straight to the jaws, but also effectually prevent it from being thrown out of the guides *a'* at the ends of the jaws, thus insuring perfect and superior work. Furthermore, any knot or enlargement in the binding can easily be detected as it passes through the guide B or folder C, and thus prevented from passing into the jaws D D'. The jaws D D' are secured together and to the frame of the binder by a screw, *h*, which passes through a slot, *i*, in the jaw D into a projection, *k*, on the jaw D', the projection *k* fitting into the slot *a* of the frame and serving as a guide. Both of the jaws can thus be adjusted together for bindings of different widths, or either jaw can be adjusted independently of the other when it is desired to apply a greater width of binding on one side of the cloth than upon the other, these adjustments being made independently of the screw by which the frame A is attached to the machine. The under jaw, D', slides in a groove, 8, formed in the under side of the frame A, so as to allow the frame to lie flat upon the top plate of the machine. The groove also serves as a guide to steady the jaw. The upper jaw, D, is steadied and prevented from moving laterally by two projections, *ll*, which serve as guides.

E is a spring-guide, which serves to hold the binding down flat upon the cloth until it is se-

cured by the needle. This guide is made adjustable by means of the clamping-screw *m* and slot *n*, so that its outer end may be thrust out to the edge of the binding and firmly held in that position to prevent the latter from turning up. The object of the spring-guide *E* is to enable the jaws *D D'* to be removed sufficiently far from the feeding device to prevent the latter from coming into contact therewith, and as the spring-guide *E* is immediately over the feed it will yield and accommodate itself to the latter as it rises and falls, and thus serves to hold the edge of the binding at all times flat down upon the cloth, as required. The corner *p* of the spring *E* is slightly turned up, so as to prevent any liability of its catching in the binding as it is carried past it.

The above-described attachment is of simple construction, easily adjusted, and not liable to get out of order, and by its use a binding of any width can be automatically guided, so that the work will be performed in a superior manner without requiring the use of the hands, which are thus free to take hold of and guide

the cloth or fabric being bound as it is carried along, whereas with binding attachments as heretofore constructed, one hand is required to guide the binding, leaving one hand only to guide and arrange the cloth as it passes along, which is not sufficient, and is inconvenient except for experts.

What I claim as my invention, and desire to secure by Letters Patent, is—

1. The adjustable guide *B* and folder *C*, constructed and arranged on the arm *b*, as described, in combination with the adjustable jaws *D D'*, as and for the purpose set forth.

2. In combination with the above, the spring-guide *E*, with its clamping-screw *m* and slot *n*, arranged and operating substantially as and for the purpose described.

Witness my hand this 20th day of July, A. D. 1870.

JOSEPH W. SAWYER.

In presence of—

W. J. CAMBRIDGE,
L. E. BATCHELLER.