

(No Model.)

4 Sheets—Sheet 1.

J. P. TIRRELL.
AUTOMATIC CUT OUT.

No. 446,902.

Patented Feb. 24, 1891.

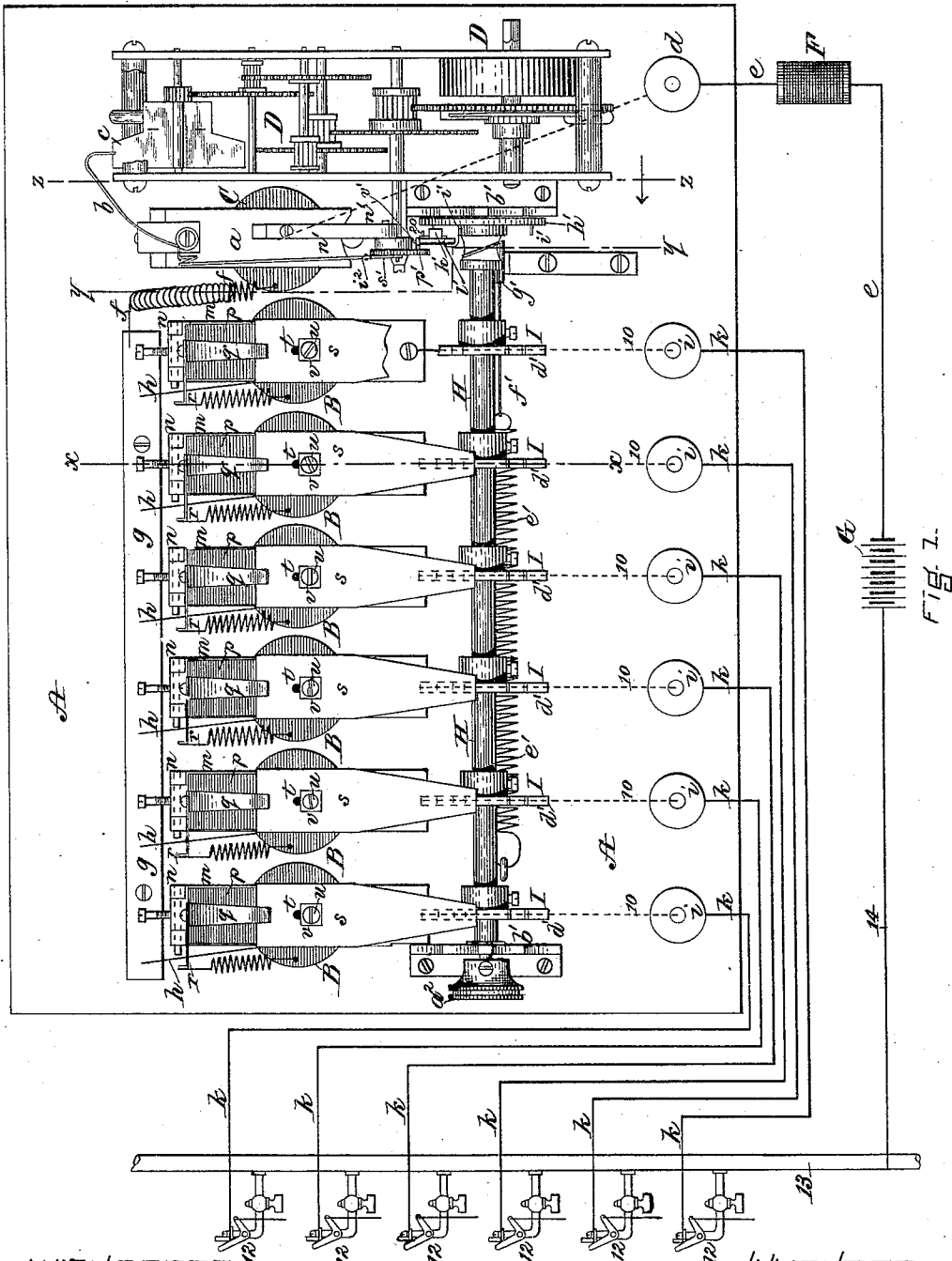

WITNESSES.
A. D. Grover
F. W. Lynde

INVENTOR.
Jacob P. Tirrell
By R. C. Schumacher
Atty

(No Model.)

4 Sheets—Sheet 2.

J. P. TIRRELL.
AUTOMATIC CUT OUT.

No. 446,902.

Patented Feb. 24, 1891.

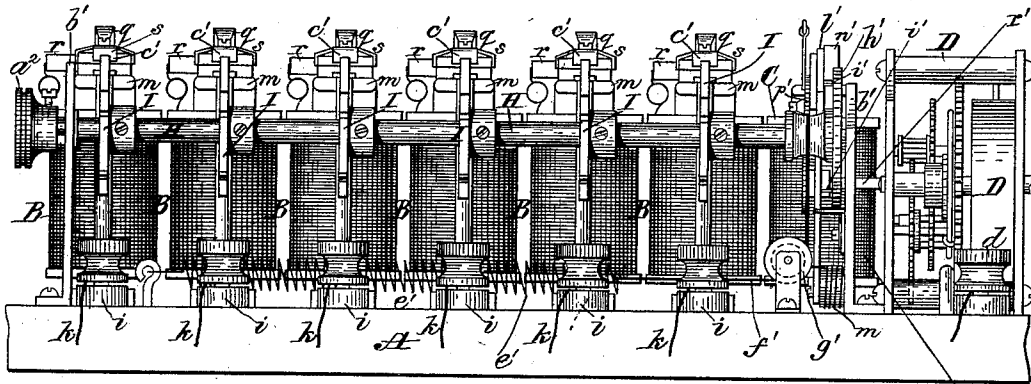

FIG. 2.

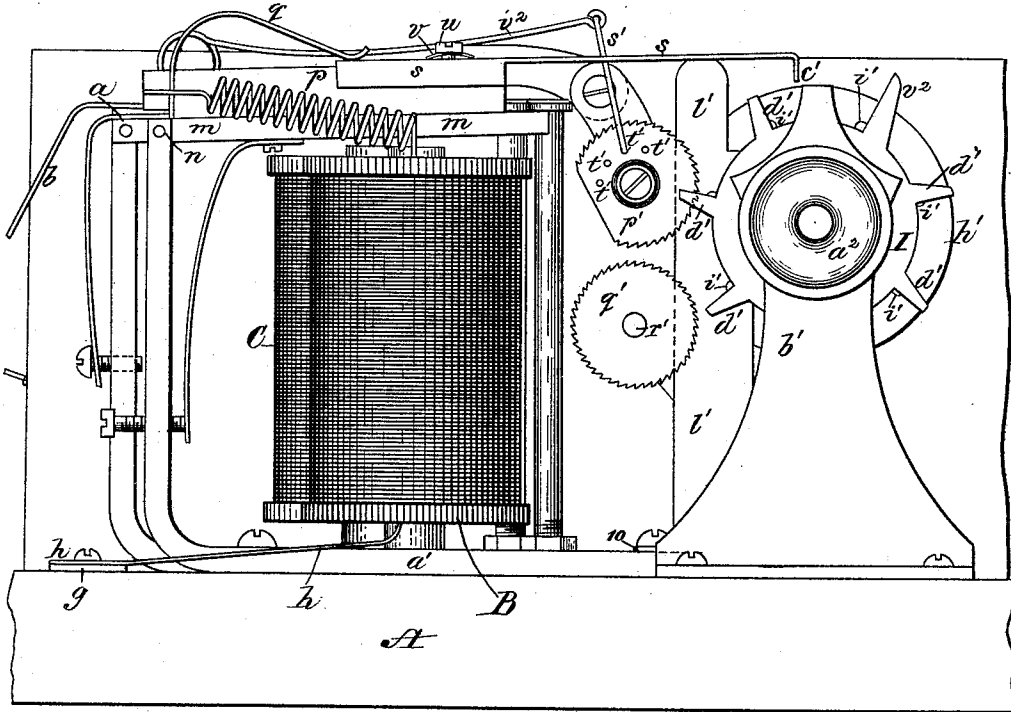

FIG. 3.

WITNESSES.

A. D. Grover
F. W. Lynde

INVENTOR.

Jacob P. Tirrell
By R. P. Steinhilber
Atty

J. P. TIRRELL.
AUTOMATIC CUT OUT.

No. 446,902.

Patented Feb. 24, 1891.

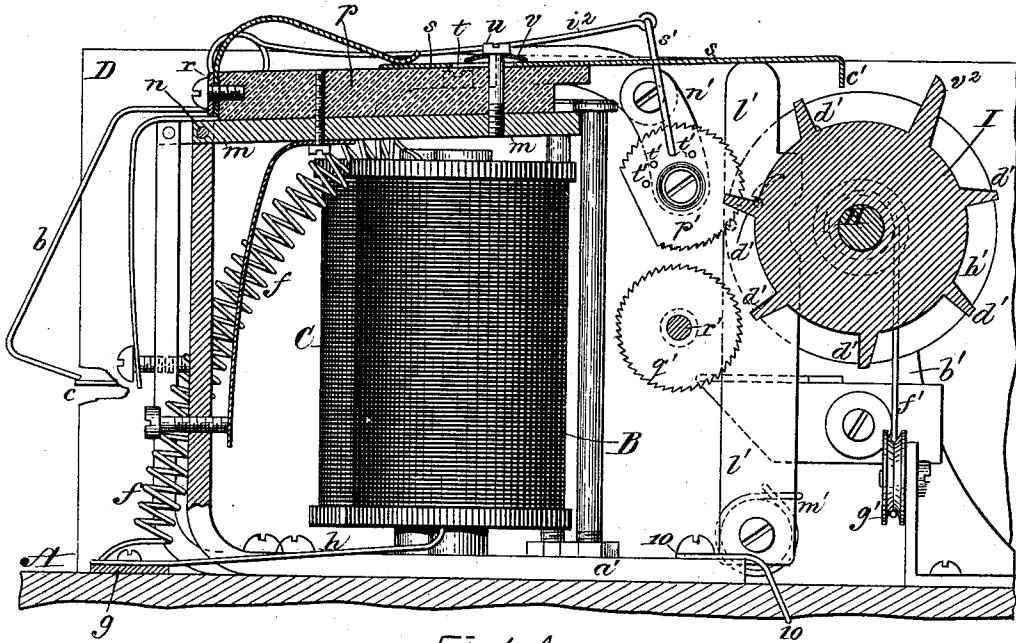

Fig. 4.

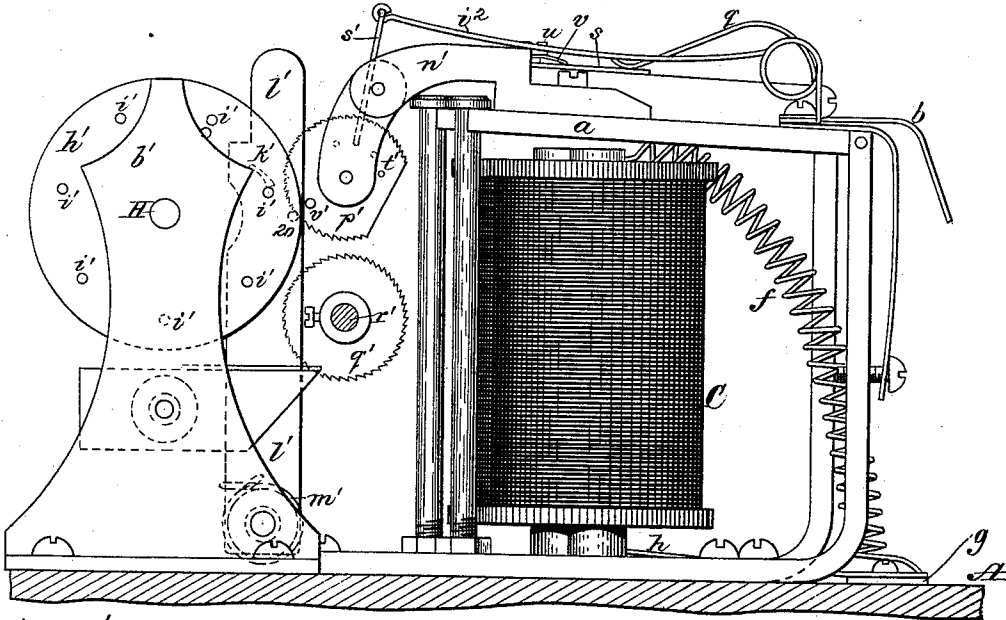

Fig. 6.

WITNESSES.

A. D. Brown
F. W. Lynde

INVENTOR—

J. P. Tirrell
By J. R. Stehman

(No Model.)

4 Sheets—Sheet 4.

J. P. TIRRELL.
AUTOMATIC CUT OUT.

No. 446,902.

Patented Feb. 24, 1891.

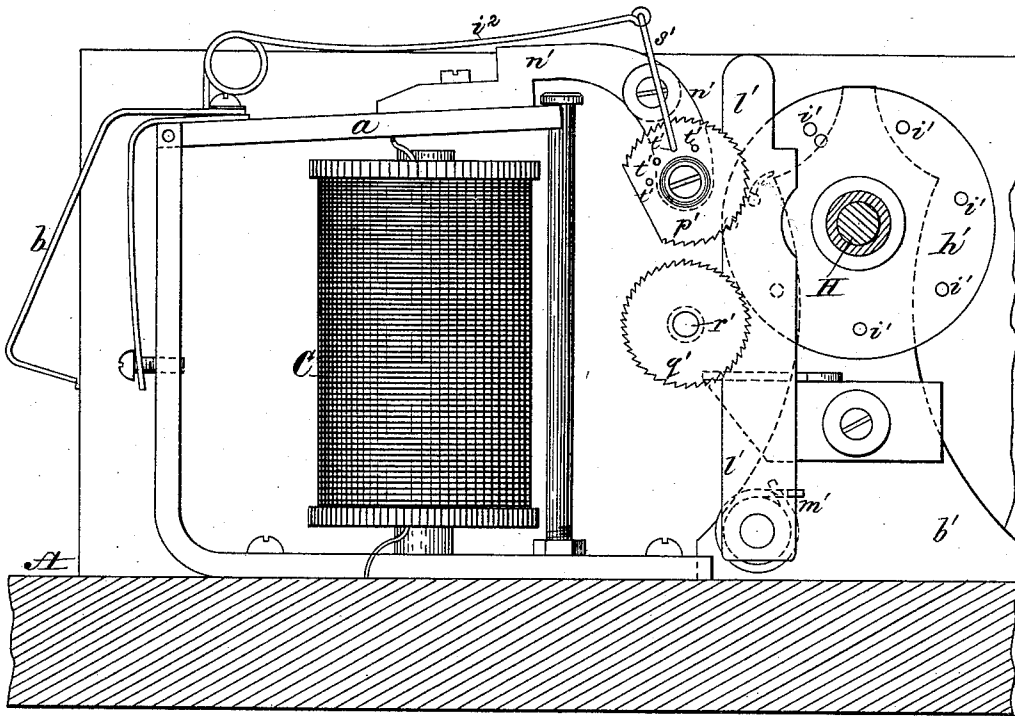

FIG. 5.

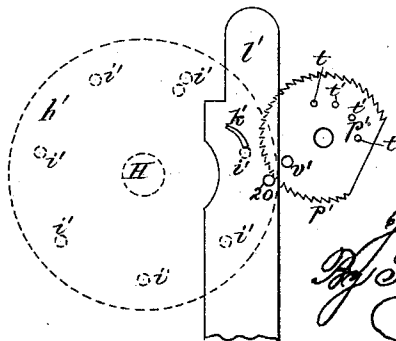

FIG. 7.

WITNESSES.

A. D. Brown
F. W. Lynde

INVENTOR-

Jacob P. Tirrell
By R. S. Schumacher
Atty

UNITED STATES PATENT OFFICE.

JACOB P. TIRRELL, OF BOSTON, MASSACHUSETTS, ASSIGNOR TO HORACE A. PINKHAM, OF PHILADELPHIA, PENNSYLVANIA.

AUTOMATIC CUT-OUT.

SPECIFICATION forming part of Letters Patent No. 446,902, dated February 24, 1891.

Application filed June 4, 1888. Serial No. 276,043. (No model.)

To all whom it may concern:

Be it known that I, JACOB P. TIRRELL, a citizen of the United States, residing at Boston, in the county of Suffolk and State of Massachusetts, have invented certain Improvements in Apparatus for Automatically Opening Closed Circuits, of which the following is a full, clear, and exact description, reference being had to the accompanying drawings, making part of this specification, in which—

Figure 1 is a plan of my improved apparatus. Fig. 2 is a front elevation of the same. Fig. 3 is an enlarged end elevation of the same. Fig. 4 is an enlarged transverse vertical section on the line xx of Fig. 1. Fig. 5 is an enlarged transverse vertical section on the line yy of Fig. 1. Fig. 6 is an enlarged transverse vertical section on the line zz of Fig. 1, looking in the direction of the arrow. Fig. 7 is a detail.

My invention relates, mainly, to electric gas-lighting apparatus embodying a system having a series of branch circuits each including one or more gas-burners; but my invention may also be applied to circuits for burglar-alarms, railway-signals, or other similar circuits containing a number of devices which are occasionally thrown into action by the closure of the circuit; and my invention has for its object to provide a more simple, effective, and reliable apparatus than has hitherto been produced for automatically cutting out a branch circuit in case of an accidental ground-connection caused by the derangement of the terminal or contact points or otherwise, thereby preventing waste of battery-power and consequent derangement of the other branch circuits in the system.

To this end my invention consists in the combination of an electric circuit having one or more independent branch circuits, each provided with gas-lighting devices or other means for making and breaking the circuit, and an electro-magnet having connected with its armature a movable switch or circuit-breaker adapted to cut out said branch circuit, an electro-magnet included in the main circuit, a clock-work mechanism adapted to

be set in motion and controlled by the armature of the electro-magnet in the main circuit, and a device adapted to be brought into action by said clock-work mechanism after the latter has been allowed to run continuously for a predetermined length of time by the prolonged closure of the circuit for moving the switch or circuit-breaker of any one of the branch-circuit electro-magnets the armature of which has been attracted by the closure of the circuit, whereby said branch circuit is cut out, as hereinafter more particularly set forth.

My invention also consists in certain combinations of parts and details of construction, as hereinafter set forth and specifically claimed.

In the said drawings, A represents a wooden base, to which are secured a series of electro-magnets B, one for and included within each branch circuit of an electric gas-lighting system, said branch circuit including one or more gas-lighting devices.

C is an auxiliary electro-magnet, the armature a of which sets in motion and controls the clock-work mechanism D, to be hereinafter described, the said armature carrying a bent wire b , which, when the armature is not attracted, rests against the fly c of the clock-work and prevents it from rotating. The electro-magnet C is connected to one pole of the battery G, Fig. 1, by a wire leading directly to the binding-post d , with which the wire e from the battery is connected, a spark-coil F being introduced into the circuit, as usual, to produce a more powerful igniting-spark at the gas-burner. The electro-magnet C is connected by a wire f with a long metal plate or strip g , secured to the base A, which strip g is also connected by separate wires h with each of the electro-magnets B of the branch circuits, which are each connected by a wire i with one of the binding-posts l , the latter being connected by separate branch wires k with the several gas-burners 12 in the system, as seen in Fig. 1, whereby the current is caused on the closure of the circuit at a gas-burner to pass by the gas-pipe 13 back to the other pole of the battery, which is con-

nected with the said gas-pipe in the usual manner by a wire 14.

Each of the electro-magnets B consists of a single coil, its armature *m* being pivoted to one of its poles at *n* and having secured to its upper surface a block *p*, of some suitable insulating material, to the rear end of which is secured a contact-spring *q*, connected by a metal strip *r* with the coil of the magnet.

Upon the insulating-block *p* is secured a sliding switch or circuit-breaker *s*, which is normally in contact with the contact-spring *q*, said switch being provided with a slot *t*, through which passes a screw-pin *u*, by which the switch is held in place upon the insulating-block, a spring-washer *v* being placed under the head of the screw-pin *u* to produce the necessary friction to hold the switch *s* in place after it has been moved by mechanism to be hereinafter described. The lower end of the pin *u* is screwed into the armature *m* and forms a connection through which the current passes from the sliding switch *s* to the armature *m*, thence to the pole of the electro-magnet, and by its metallic base *a'* and wire 10 to one of the binding-posts *i*, and thence back to the battery.

H is a horizontal shaft which is placed in front of the electro-magnets B and is supported in suitable bearings in uprights *b'*. The shaft *H* carries a series of toothed wheels *I*, which are arranged one opposite to each electro-magnet B and in line with its armature and switch or circuit-breaker *s*, the outer end of the latter being bent down, forming a hook *c'*, which lies over the toothed wheel *I*, and is so placed with relation to the shorter teeth *d'* of the said wheel that when the armature *m* is attracted by the closure of the circuit in which it is included it will be in a position to be struck by one of the teeth *d'* of the wheel *I* when the latter is partially rotated in a manner to be hereinafter described. The contact of the tooth of the wheel *I* with the switch *s* causes it to be drawn forward until its rear end is out of contact with its contact-spring *q*, when the circuit will be broken, causing that particular branch circuit to be cut out and leaving all the other branch circuits in an operative condition.

The shaft *H* is rotated by the action of a long spiral spring *e'*, to one end of which is secured a cord *f'*, passing over a pulley *g'* and secured to a grooved hub on the said shaft, the latter being held against the force of the spring by an escapement-wheel *h'*, secured thereto and provided with laterally-projecting pins *i'*, one of which is at all times in a position to be caught and held by a detent or inclined projection *k'* on a lever *l'*, which is pivoted at its lower end and provided with a spring *m'*. The lever *l'* is also provided beneath the projection *k'* and a little on one side of the same with a pin 20, which serves to catch the succeeding pin *i'* of the escapement-

wheel when it is released by the movement of the lever *l'*, and on the return movement of the lever the pin *i'* slips off the pin 20 and is caught and held by the projection *k'* until the next movement of the lever *l'*. The lever *l'* is moved to release the escapement-wheel and allow it and the shaft *H* to rotate a distance equal to that between two of its pins *i'* in the following manner:

To the armature *a* of the electro-magnet C is secured a jointed arm *n'*, from the lower end of which projects a stud upon which is mounted a gear *p'*, which is arranged immediately over a gear *q'*, secured to one of the arbors *r'* of the clock-work mechanism D and at such a distance therefrom that when the armature of the electro-magnet C is attracted by the closure of the circuit the gear *p'* will be caused to engage with the gear *q'*, by which it will then be rotated. The teeth of the gears *p' q'* are inclined on one side and straight on the other side, which shape causes them to remain in engagement without any tendency to separate, and a portion of the periphery of the gear *p'* is flattened and left without teeth in order that the gears may be disengaged at the proper time to allow the armature *a* to rise and arrest the movement of the clock-work. Otherwise, if the teeth extended entirely around the gear *p'*, the friction between the teeth of the gears *p' q'* would be liable to hold them constantly in engagement and prevent the armature *a* from being withdrawn by its spring. The momentary closure of the circuit for lighting purposes will release the clock-work for an instant only and cause a very slight movement of the gear *p'*, which will be instantly returned to its normal position when the armature is withdrawn by a light spring *i'*, carrying a wire *s'*, having a hooked end, which is placed within one of a series of holes *l'* in the side of the gear *p'*. If, however, the closure of the circuit be permanent, owing to derangement, the armature *m* of the electro-magnet B of the affected branch circuit remains attracted, as does also the armature *a* of the electro-magnet C, when the clock-work D will cause the gear *p'* to rotate until a pin *v'* on its side is brought into contact with and moves the escapement-lever *l'* sufficiently to release the wheel *h'*, which occurs after the lapse of a short time, preferably half a minute, more or less. This release of the wheel *h'* causes the shaft *H* to be partially rotated by its spring *e'* when the bent end *c'* of the switch *s* of the affected branch circuit, which has been depressed by the attraction of the armature *m*, to which it is attached, is struck by one of the teeth of the wheel *I*, in line therewith, and drawn forward to cut out the affected branch circuit, as before described. The armatures *m a* then cease to be attracted, and as the armature *a* rises the wire *b* is brought into contact with the fly *c*, thus ar-

resting the motion of the clock-work, and at the same time the gear p' is disconnected from the gear q' and is rotated back to its original position by the spring i^2 , carrying the pin v' away from the escapement-lever l' . The time required to release the escapement-wheel depends upon the distance of the pin v' from the lever l' when the gear p' commences to rotate, and consequently by changing the hooked end of the wire s' from one hole t' to another the position of the pin v' with respect to the escapement-lever l' can be varied in such manner as to cause the escapement-wheel to be released by a longer or shorter continuous action of the clock-work D, caused by the permanent closure of the circuit. A suitable stop on the escapement-wheel h' prevents it from being carried round by the spring e' more than a single revolution.

To restore the switch s' to its normal position after the fault has been remedied, it is merely necessary to turn the shaft H backward by taking hold of the milled head a^2 , when a single elongated tooth v^2 , with which each wheel I is provided, will strike the end of the switch s and slide it back into contact with its contact-spring q , when the parts will be in an operative position, and the circuit can be completed by the contact of the electrodes at the burner during the operation of lighting.

The number of short teeth on each wheel I corresponds with the number of branch circuits, whereby if two or the entire number of branch circuits become successively deranged before the fact was noticed each one would be cut out as it became deranged by one of the teeth of its wheel I, thus preventing the exhaustion of the battery.

The above-described apparatus, although specially adapted for use in electric gas-lighting circuits, may, as before stated, be used in connection with electric circuits for various other purposes—such as burglar-alarms, railway-signals, &c.—which contain devices which are brought into action occasionally by the closing of the circuit.

What I claim as my invention, and desire to secure by Letters Patent, is—

1. The combination of an electric circuit having one or more branch circuits, each provided with gas-lighting devices or other means for making and breaking the circuit, an electro-magnet having connected with its armature a movable switch or circuit-breaker adapted to cut out said branch circuit, an electro-magnet included in the main circuit, a clock-work mechanism adapted to be set in motion and controlled by the armature of the electro-magnet in the main circuit, a spring-actuated shaft H, provided with toothed wheels I, the escapement-wheel h' on the shaft H, the escapement-lever l' , a gear p' , mounted on an arm secured to the armature a of the electro-magnet C and having a pin or projec-

tion v' , adapted to actuate the escapement-lever, a gear q' upon one of the arbors of the clock-work mechanism, with which said gear p' is normally out of contact and is brought into engagement when the armature of the magnet C is attracted, whereby the escapement is operated to release the shaft H, and a spring i^2 for returning the gear p' to its normal position when thrown out of engagement with the gear q' by the withdrawal of the armature of the electro-magnet C, substantially as set forth.

2. The combination, with the electro-magnet C and its armature a and the escapement-lever l' and escapement-wheel h' on the shaft H, of the gear p' , mounted on an arm n' , secured to said armature and adapted to be rotated by engagement with a gear on one of the arbors of the clock-work mechanism when brought into contact therewith by the attraction of the armature, said gear p' having a pin or projection v' for moving the escapement-lever, and a series of holes t' for the reception of the hooked end of a spring-arm s' , whereby the said spring-arm can be adjusted to vary the normal position of the pin v' with respect to the escapement-lever l' to cause the same to be moved sufficiently to release the escapement-wheel after the clock-work has remained continuously in action for a longer or shorter period of time, substantially as set forth.

3. The combination, with an electric circuit having one or more branch circuits, each provided with gas-lighting devices or other means for making and breaking the circuit, of an electro-magnet B, having an armature m pivoted to one of its poles and carrying an insulating-block p , a switch or circuit-breaker s , sliding on said insulating-block and having a slot t and screw-pin u passing through said slot into the armature, a contact-spring q , normally in contact with the sliding switch, and a device adapted to engage with and move said switch when its armature is attracted, all operating substantially in the manner and for the purpose set forth.

4. The combination, with an electric circuit having one or more branch circuits, each provided with gas-lighting devices or other means for making and breaking the circuit, of an electro-magnet B, having an armature m pivoted to one of its poles and carrying an insulating-block p , a switch or circuit-breaker s , sliding on said insulating-block and having a slot t and screw-pin u passing through said slot into the armature, a contact-spring q , normally in contact with the sliding switch, and a shaft H, carrying a toothed wheel I, adapted to engage with and move said switch when its armature is attracted, all operating substantially in the manner and for the purpose set forth.

5. The combination, with the electro-magnets B and the switches or circuit-breakers s ,

adapted to slide upon insulating-blocks p on
their armatures m , of the shaft II and its
toothed wheels I, said wheels being each pro-
vided with an elongated tooth adapted to re-
turn the sliding switch in line therewith to
its normal position on the backward rotation
of the shaft II, substantially as set forth.

Witness my hand this 27th day of January,
A. D. 1888.

JACOB P. TIRRELL.

In presence of—

P. E. TESCHEMACHER,

JNO. H. NOLAN.