

(No Model.)

R. J. HOSNER.

DOOR HANGER.

No. 386,885.

Patented July 31, 1888.

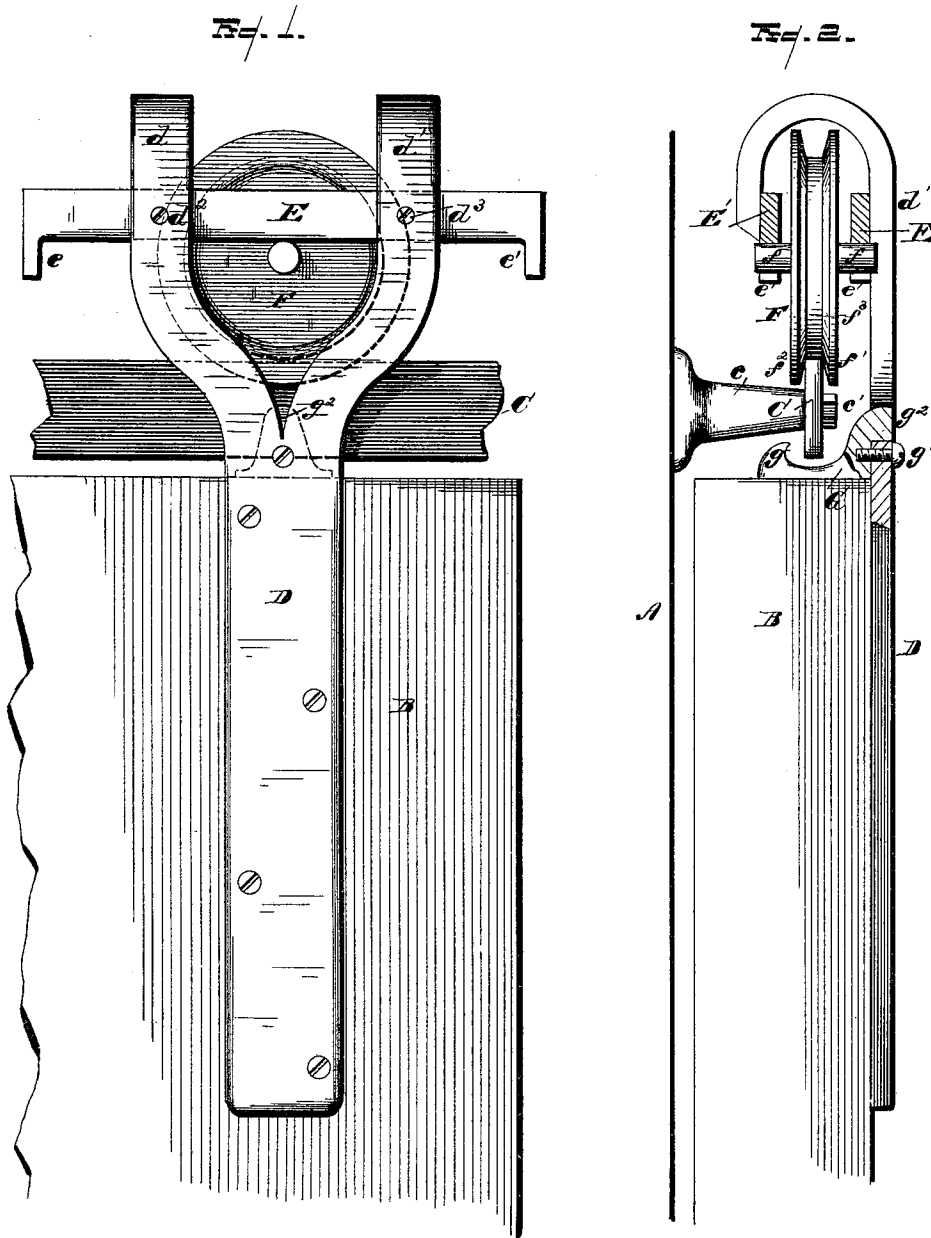

WITNESSES.

*Samuel C. Thomas.*  
*John W. Rea.*

INVENTOR.

*Riley J. Hosner.*  
*By W. W. Leggett.*  
Attorney.

# UNITED STATES PATENT OFFICE.

RILEY J. HOSNER, OF ROMEO, MICHIGAN.

## DOOR-HANGER.

SPECIFICATION forming part of Letters Patent No. 386,885, dated July 31, 1888.

Application filed June 10, 1887. Serial No. 240,911. (No model.)

To all whom it may concern:

Be it known that I, RILEY J. HOSNER, of Romeo, county of Macomb, State of Michigan, have invented a new and useful Improvement in Anti-Friction Door-Hangers; and I declare the following to be a full, clear, and exact description of the same, such as will enable others skilled in the art to which it pertains to make and use it, reference being had to the accompanying drawings, which form a part of this specification.

My invention relates to certain new and useful improvements in door-hangers, more particularly of that class denominated "anti-friction door-hangers;" and it consists in the novel construction and combination of parts hereinafter described, and more particularly pointed out in the claim.

In the drawings, Figure 1 is a side elevation; Fig. 2, an end elevation, showing parts in section.

A represents a building; B, a door.

C represents a track constructed of a bar of metal engaged with its edges in a vertical position. The bar is supported upon the building by means of a series of thimbles, *c*, and bolt *c'*, uniting the track and thimble upon the building. The track may be made thus of a thin bar of metal, its edges being extended above and below to form a sufficient tread for the supporting-roller and for the engagement of a safety-guard, as illustrated in Fig. 2.

D represents the bracket of my improved hanger, said bracket being constructed of a bar of wrought metal split at its upper end to form supporting-arms *d d'*. Said arms are spread above their integral union with the lower part of the bracket, as shown in Fig. 1, and are turned in a U shaped form, as shown in Fig. 2, at their extremities, so as to receive transverse bars *E E'*, the transverse bar *E'* being engaged with the extreme pendent ends of said arms, and the bar *E* engaged upon said arms, adjacent to the bar *E'*, so as to form an upper bearing-surface for the journal *f* of the supporting-roller *F*. The transverse bars may be supported in engagement with the arms *d d'* in any suitable manner, as by screws *d<sup>2</sup> d<sup>2</sup>*. This roller is constructed with flanges *f' f'*, projecting from the tread *f<sup>3</sup>*, to constitute retaining-flanges extending downward over the upper edge of the track, as shown in Fig. 2. The ends of the transverse bars *E E'* are terminated with depending flanges *e e'* upon the opposite ends of said bar

to prevent any liability of the disengagement of the journal of the supporting-roller from said transverse bars in shifting the door to and fro and confining the roller in place upon the track in its relation to said bars.

In the ordinary operation of the door there will be no liability whatever of the disengagement of the roller from the track. Certain emergencies, however, are liable to occur, whereby the lower end of the door may be swung outward, and to prevent the disengagement of the roller from the track in such an event I provide a safety guard, *G*. The guard is constructed with an upturned flange or point, *g*, arranged to extend upwardly in the rear of the lower edge of the track, the guard being at its opposite end preferably engaged with the bracket of the hanger in any suitable way—as, for instance, by means of a screw, *g'*. I prefer also to construct this guard, which may be made of a malleable casting, with a shoulder, *g<sup>2</sup>*, projecting from the outer end of the guard and shaped to enter the recess formed between the two arms *d d'* of the bracket at the point of their integral union with the base of the bracket. By constructing the guard with this shoulder *g<sup>2</sup>*, thus engaged between the two arms, firmness is given to the union of the guard with the bracket in a very simple manner, an ordinary screw serving every purpose to hold the two in proper relation to each other. By the employment of this safety-guard any unusual liability for the door to be thrown from the track is thereby prevented, while at the same time in the ordinary operation the guard is clear of the track and all friction is ordinarily avoided, the guard serving its function only in rare cases.

What I claim is—

In combination, the door hanger bracket *D*, having bifurcated arms *d d'*, the track *C*, the roller *F*, and the guard *G*, having an upturned flange or point, *g*, extended in rear of the lower edge of the track, and a shoulder, *g<sup>2</sup>*, engaged between the bifurcated arms of the bracket, the guard *G* being secured to the bracket *D* by means of a screw, substantially as shown and described.

In testimony whereof I sign this specification in the presence of two witnesses.

RILEY J. HOSNER.

Witnesses:

M. B. O'DOHERTY,  
SAMUEL E. THOMAS.