

G. W. & J. A. GEROW.
SELF-HEATING SAD-IRON.

No. 176,294.

Patented April 18, 1876

Fig. 1.

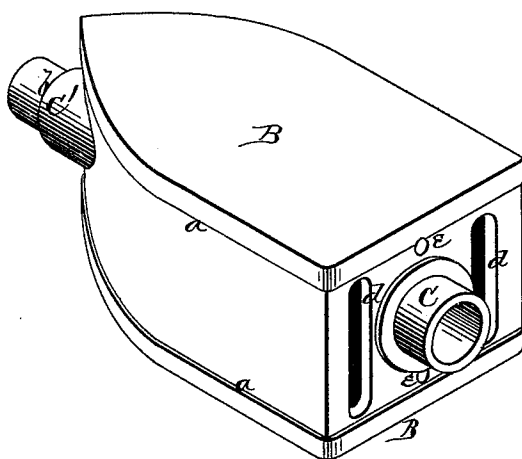
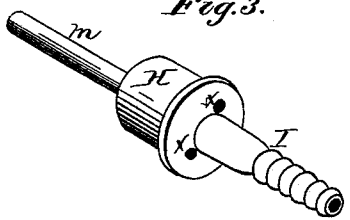

Fig. 3.



WITNESSES
Henry N. Miller
C. L. Evers By

INVENTOR
G. W. Gerow
J. A. Gerow
per *Alexander Mason*
Attorney

G. W. & J. A. GEROW.
SELF-HEATING SAD-IRON.

No. 176,294.

Patented April 18, 1876.

Fig. 2.

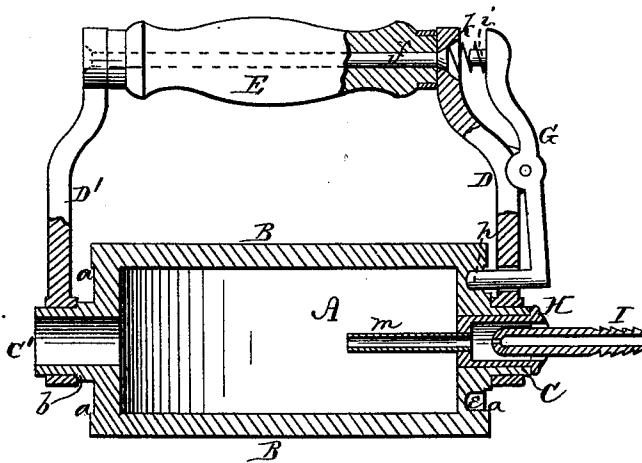

WITNESSES

Henry N. Miller
C. L. Everh.

INVENTOR

G. W. Gerow.
J. A. Gerow.
per Alexander Mason
ATTORNEYS

UNITED STATES PATENT OFFICE.

GIDEON W. GEROW, OF TOLEDO, AND JOHN A. GEROW, OF FINDLEY, OHIO.

IMPROVEMENT IN SELF-HEATING SAD-IRONS.

Specification forming part of Letters Patent No. 176,294, dated April 18, 1876;—application filed March 30, 1876.

To all whom it may concern:

Be it known that we, GIDEON W. GEROW, of Toledo, Lucas county, Ohio, and JOHN A. GEROW, of Findley, in the county of Hancock and in the State of Ohio, have invented certain new and useful Improvements in Sad-Irons; and do hereby declare that the following is a full, clear, and exact description thereof, reference being had to the accompanying drawings and to the letters of reference marked thereon, making a part of this specification.

The nature of our invention consists in the construction of a reversible sad-iron, as more fully hereinafter set forth and claimed.

In order to enable others skilled in the art to which our invention appertains to make and use the same, we will now proceed to describe its construction and operation, referring to the annexed drawings, in which—

Figure 1 is a perspective view of our sad-iron, with the handle and burner removed. Fig. 2 is a longitudinal section of the sad-iron with the handle and burner in place. Fig. 3 is a perspective view of the burner.

A represents the body of our sad-iron, cast hollow in one piece, of the usual form, with two steel faced or hardened surfaces, B B. These surfaces extend around the sides of the body A, forming shoulders *a a*, as shown in Fig. 1.

In the center of the heel of the iron A is formed a hollow journal, C, and a similar journal, C', is formed in the center of the point of the iron. This latter journal is provided with a circumferential shoulder at *b*.

On each side of the journal C, in the heel of the iron, is a vertical slot, *d*, for the admission of air into the interior of the iron, and above and below the same journal are recesses *e e*, as shown.

D D' represent two arms, having eyes at their lower ends, which are placed respectively on the hollow journals C C'. The upper ends are connected by means of a rod, *f*, upon which is placed an ordinary wooden handle, E.

On the outer side of the arm D is pivoted a lever, G, the lower end of which extends at right angles in the form of a pin, *h*, that

passes through a hole in the arm and into one of the recesses *e*, thereby holding the iron in place between the arms D D', as shown in Fig. 2. On the inner side, at the upper end of the lever G, is a stud or small pin, *i*, upon which is placed a spiral spring, *k*, that rests in a recess in the upper end of the arm. The spring *k* holds the pin *h* of the lever G in its place in the recess. By pressing on the upper end of the lever the pin *h* is withdrawn from the recess, when the iron can be turned around to bring the other surface up when the pin springs into the other recess to hold the iron.

In the hollow journal C is inserted a hollow cylindrical plug, H, closed at both ends. In the center of the inner end of the plug H is inserted a tube, *m*, and in the center of the outer end is inserted a burner, I, which extends into the hollow plug for a suitable distance. The outer end of the burner is corrugated, as shown, circumferentially, so as to render it easy to attach a rubber tube, the other end of said tube being placed on any gas-burner in the room convenient to the place where the iron is to be used.

Through the outer end of the hollow plug H are made one or more small apertures, *x*, for the admission of air into the plug to mix with the gas as it escapes from the burner I, and before it enters the tube *m* to be burned within the iron.

The entire burner H I *m*, thus constructed, is removable from the hollow journal C at any time when desired.

We are aware that a hollow reversible sad-iron is, broadly, not new.

Having thus fully described our invention, what we claim as new, and desire to secure by Letters Patent, is—

1. The combination of the hollow reversible sad-iron, having faces B B, journals C C', and recess *e*, with the arms D D', rod *f*, and pivoted lever G, with spring *k*, and pin *h*, all constructed substantially as set forth.

2. The combination, with a hollow sad-iron, of a gas-burner, consisting of a detachable hollow plug, H, closed at both ends and pro-

vided with the tube *m*, detachable burner I, and air-holes *x x*, substantially as herein set forth.

3. The combination of the the hollow reversible sad-iron A B, having hollow journals C C', handle D E, fastening-lever G and burner H I *m*, all constructed substantially as and for the purposes herein set forth.

In testimony that we claim the foregoing we have hereunto set our hands this 21st day of December, 1874.

GIDEON W. GEROW.
JOHN A. GEROW.

Witnesses:

A. G. CLARK,
M. J. FLETCHER.