



(86) Date de dépôt PCT/PCT Filing Date: 2017/04/04  
 (87) Date publication PCT/PCT Publication Date: 2017/10/12  
 (45) Date de délivrance/Issue Date: 2022/06/21  
 (85) Entrée phase nationale/National Entry: 2018/09/25  
 (86) N° demande PCT/PCT Application No.: EP 2017/057918  
 (87) N° publication PCT/PCT Publication No.: 2017/174541  
 (30) Priorité/Priority: 2016/04/04 (EP16163692.3)

(51) Cl.Int./Int.Cl. *B61L 15/00* (2006.01),  
*B61L 25/02* (2006.01)  
 (72) Inventeurs/Inventors:  
BAUER, HARALD, DE;  
LAUTERBERG, VEIT, DE;  
WALLNER, CHRISTIAN, DE;  
MINDEL, KLAUS, DE  
 (73) Propriétaire/Owner:  
THALES MANAGEMENT & SERVICES  
DEUTSCHLAND GMBH, DE  
 (74) Agent: CASSAN MACLEAN IP AGENCY INC.

(54) Titre : PROCÉDE DE SURVEILLANCE SECURISEE DE L'INTEGRITE D'UN TRAIN ET UTILISATION D'UNITES EMBARQUEES D'UN SYSTEME DE PROTECTION AUTOMATIQUE DE TRAIN POUR SURVEILLER L'INTEGRITE D'UN TRAIN

(54) Title: METHOD FOR SAFE SUPERVISION OF TRAIN INTEGRITY AND USE OF ON-BOARD UNITS OF AN AUTOMATIC TRAIN PROTECTION SYSTEM FOR SUPERVISION TRAIN INTEGRITY

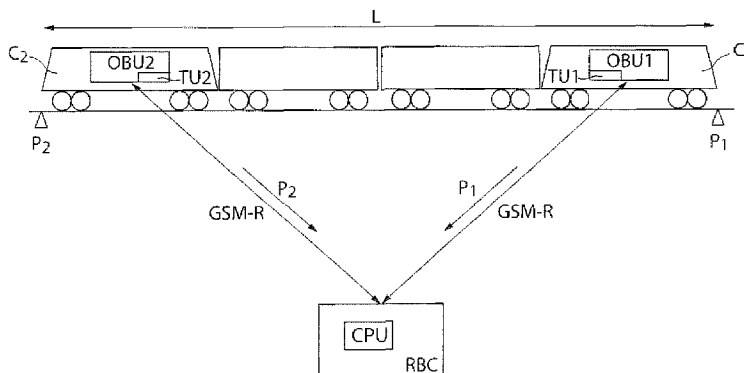

(57) **Abrégé/Abstract:**

The invention concerns a method for safe supervising train integrity, the method comprising: a) acquiring first position data (P1) of the first carriage (C1) via a first tracking unit (TU1) which is installed on-board of a first carriage (C1) and acquiring second position data (P2) of a second carriage (C2) via a second tracking unit (TU2) which is installed on-board of the second carriage (C2), wherein the position data (P1, P3) is related to a rail route coordinate system. b) determining a deviation ? between a reference value which depends on the length L of the train and a position value which depends on position data (P1, P2) of at least one of the tracking units (TU1, TU2); c) detecting whether train integrity is given by analyzing the deviation; d) Repeating steps a) through c); wherein the tracking units (TU1, TU2) are part of on-board units (OBU1, OBU2) of an automatic train protection system. Thus a cost-efficient method for supervising train integrity which complies with safety level SIL4 can be realized.

(12) INTERNATIONAL APPLICATION PUBLISHED UNDER THE PATENT COOPERATION TREATY (PCT)

(19) World Intellectual Property  
Organization  
International Bureau(10) International Publication Number  
**WO 2017/174541 A1**(43) International Publication Date  
12 October 2017 (12.10.2017)

## (51) International Patent Classification:

**B61L 15/00** (2006.01) **B61L 25/02** (2006.01)  
**B61L 27/00** (2006.01)

## (21) International Application Number:

PCT/EP2017/057918

## (22) International Filing Date:

4 April 2017 (04.04.2017)

## (25) Filing Language:

English

## (26) Publication Language:

English

## (30) Priority Data:

16163692.3 4 April 2016 (04.04.2016) EP

(71) Applicant: **THALES DEUTSCHLAND GMBH**  
[DE/DE]; Thalesplatz 1, 71254 Ditzingen (DE).(72) Inventors: **BAUER, Harald**; Lindenstr. 8, 71522 Back-  
nang (DE). **LAUTERBERG, Veit**; Rheinstrasse 19, 75242  
Neuhausen (DE). **WALLNER, Christian**; Kapuzinerberg  
19, 71263 Weil der Stadt (DE). **MINDEL, Klaus**; Bogen-  
straße 15/2, 71563 Affalterbach (DE).(74) Agent: **KOHLER SCHMID MÖBUS PATENTAN-  
WÄLTE PARTNERSCHAFTSGESELLSCHAFT  
MBB**; Gropiusplatz 10, 70563 Stuttgart (DE).(81) Designated States (unless otherwise indicated, for every  
kind of national protection available): AE, AG, AL, AM,  
AO, AT, AU, AZ, BA, BB, BG, BH, BN, BR, BW, BY,  
BZ, CA, CH, CL, CN, CO, CR, CU, CZ, DE, DJ, DK, DM,  
DO, DZ, EC, EE, EG, ES, FI, GB, GD, GE, GH, GM, GT,  
HN, HR, HU, ID, IL, IN, IR, IS, JP, KE, KG, KH, KN,  
KP, KR, KW, KZ, LA, LC, LK, LR, LS, LU, LY, MA,  
MD, ME, MG, MK, MN, MW, MX, MY, MZ, NA, NG,  
NI, NO, NZ, OM, PA, PE, PG, PH, PL, PT, QA, RO, RS,  
RU, RW, SA, SC, SD, SE, SG, SK, SL, SM, ST, SV, SY,  
TH, TJ, TM, TN, TR, TT, TZ, UA, UG, US, UZ, VC, VN,  
ZA, ZM, ZW.(84) Designated States (unless otherwise indicated, for every  
kind of regional protection available): ARIPO (BW, GH,  
GM, KE, LR, LS, MW, MZ, NA, RW, SD, SL, ST, SZ,  
TZ, UG, ZM, ZW), Eurasian (AM, AZ, BY, KG, KZ, RU,  
TJ, TM), European (AL, AT, BE, BG, CH, CY, CZ, DE,  
DK, EE, ES, FI, FR, GB, GR, HR, HU, IE, IS, IT, LT, LU,  
LV, MC, MK, MT, NL, NO, PL, PT, RO, RS, SE, SI, SK,  
SM, TR), OAPI (BF, BJ, CF, CG, CI, CM, GA, GN, GQ,  
GW, KM, ML, MR, NE, SN, TD, TG).

## Published:

— with international search report (Art. 21(3))

(54) Title: METHOD FOR SAFE SUPERVISION OF TRAIN INTEGRITY AND USE OF ON-BOARD UNITS OF AN AUTO-  
MATIC TRAIN PROTECTION SYSTEM FOR SUPERVISION TRAIN INTEGRITY

Fig. 2

(57) Abstract: The invention concerns a method for safe supervising train integrity, the method comprising: a) acquiring first posi-  
tion data (P1) of the first carriage (C1) via a first tracking unit (TU1) which is installed on-board of a first carriage (C1) and acquir-  
ing second position data (P2) of a second carriage (C2) via a second tracking unit (TU2) which is installed on-board of the second  
carriage (C2), wherein the position data (P1, P2) is related to a rail route coordinate system. b) determining a deviation  $\Delta$  between a  
reference value which depends on the length L of the train and a position value which depends on position data (P1, P2) of at least  
one of the tracking units (TU1, TU2); c) detecting whether train integrity is given by analyzing the deviation; d) Repeating steps a)  
through c); wherein the tracking units (TU1, TU2) are part of on-board units (OBU1, OBU2) of an automatic train protection sys-  
tem. Thus a cost-efficient method for supervising train integrity which complies with safety level SIL4 can be realized.

WO 2017/174541 A1

**Method for safe supervision of train integrity and use of on-board units of an automatic train protection system for supervision train integrity**

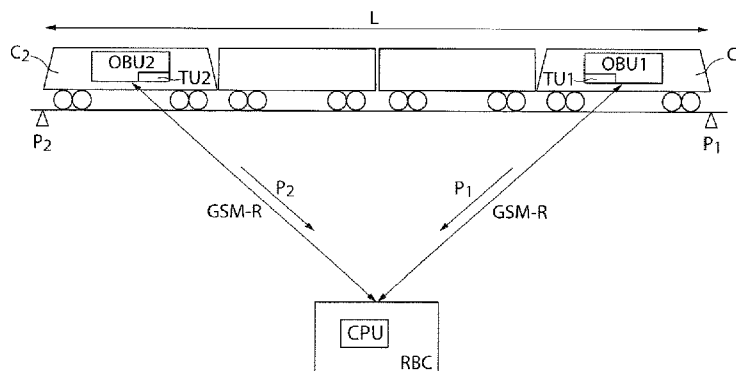
Background of the invention

- 5 The invention concerns a method for supervision of the integrity of a train and the use of on-board units of an automatic train protection system for supervision of train integrity.

A method for supervision of train integrity is disclosed in EP 2 531 391 B1 and ZA 2004 037 05.

One important aspect of safe railway operation is to avoid collisions between trains which often happen due to lost carriages.

5 A common solution is the detection of track vacancy. Entering a section already occupied by another train will be prohibited in this way. Traditionally this track vacancy detection is done via track side equipment such as track circuits and axle counters. Yet, in order to grant operability this track side equipment needs extensive maintenance.

10 An alternative solution is implicit track free detection by a continuously monitoring of train front or rear position and train integrity. This solution is already specified in the ETCS level 3 (specified by the UNISIG standard).

15 ZA 2000 056 12 discloses means for detecting loss of train integrity comprising axle rotation-time interval counters at the front and back ends of a train. The count at the back are transmitted to the front where the count are compared and a discrepancy above a predetermined limit gives rise to an alarm signal and/or other desired or required reaction. Yet, the direction of rotation is not considered with the described method. Further, errors of the single sensors are cumulated, e.g. due to discrepancy of wheel diameters)

20 EP 2 531 391 B1 discloses a method for monitoring train integrity, wherein position data is acquired by means of a plurality of train integrity modules (TIM) which are positioned within carriages of the train. A digital map is provided indicating the position of shunting areas, wherein the TIMs exchange data during a calibration phase by means of near field communication while leaving the shunting area. Sensor data (speed, position, moving direction) are exchanged between the train integrity modules until the respective carriages reach a second shunting area. The data is transmitted to a control center. The sensor data of different TIMs are acquired via GNSS

and are compared with each other. In case the data of different TIMs comply with each other the TIMs are supposed to be located at the same train. The TIMs have to be installed permanently at the carriages which makes the known method expensive.

- 5 ZA 2004 037 05 discloses a method for reporting train integrity by use of GPS devices located in a front unit and in a back unit of a train. The GPS units report speed simultaneously and with the use of telemetry equipment the speed measurements are brought together and are compared for discrepancy.
- 10 A disadvantage of the GPS-based methods disclosed in EP 2 531 391 B1 and ZA 2004 037 05 is that poor satellite reception due to insufficient satellite coverage or tunnels impair the availability.

None of the known methods for controlling train integrity can be ensure safety at the required SIL4-level.

15 Object of the invention

It is therefore an object of the invention to suggest a cost-efficient method for supervising train integrity which complies with safety level SIL4.

Description of the invention

This object is solved by a method as described herein.

- 20 According to the invention a method for safe supervision of the integrity of a train is suggested, in particular at SIL4-level, wherein the train comprising a first carriage and a second carriage. The inventive method comprises:

- a) acquiring first position data of the first carriage via a first tracking unit which is installed on-board of the first carriage and acquiring second  
25 position data of the second carriage via a second tracking unit which is

installed on-board of the second carriage, wherein the position data is related to a rail route coordinate system;

- b) determining a deviation  $\Delta$  between a reference value which depends on the length L of the train and a position value which depends on position data of at least one of the tracking units;
- c) detecting whether train integrity is given by analyzing the deviation;
- d) Repeating steps a) through c).

According to the invention SIL4-prooved tracking units are used. The tracking units use the same coordinate system for position determination.

The inventive method uses a safe system for position determination, which allows monitoring of the length of a train with SIL4 and ensuring reliably that the train was not split or additional carriages were coupled, by using existing on-board equipment. Thus information concerning the completeness of the train (train integrity) can be achieved without the need to provide additional train integrity equipment such as sensors and power supply.

The position data are rail route coordinate system related, i.e. "position" is a point within the rail route coordinate system. A point in this coordinate system (position) is expressed by a distance along the rail route to a reference point (well-defined point on a rail route with a known and measurable relation to a prominent stationary point (reference point), e.g. signal location, switch location, danger point location, platform end location). Position and sequence of the reference points have to be known.

In a preferred variant the position data is determined via distance measurement along a rail route coordinate system (continuous counting of kilometers along a track) with reference to at least one reference point. According to the invention absolute localization of railway vehicles in a rail route coordinate system is used. Two tracking units are used, wherein the tracking units take into consideration the rail route coordinate system (one-dimensional coordinate system along the rail route) of the train.

The position value may be the distance between the first tracking unit and the second tracking unit which can be determined by subtraction of the first and the second (rail route coordinate system related) position data. The reference point is supposed to be the origin of ordinates of the rail route coordinate system and may be implemented in a machine readable manner (e.g. in form of an Eurobalise) in order to support train borne positioning systems. For position determination the direction of passing the reference point as well as is considered. Thus for determination of the position data a reference point, the distance of the tracking units to the reference point and the moving direction of the train should be known. Instead of using distance measurement along a rail route coordinate system during detection of the position data it is also possible to convert preliminary (not rail route coordinate system related) position data (e.g. position data received via GNSS or Camera based systems using track specific patterns), into position data of the respective rail route coordinate system subsequent to acquisition of position data, e.g. by means of a map containing the track routing.

A multitude of reference points can be used within one rail route, wherein an actual reference point is used for determining the position data. Preferably the reference point that has been passed most recently is used as actual reference point. Near each branch point of the track a reference point is recommended. The last reference point of the first tracking unit may serve as actual reference point for the second tracking unit.

In a highly preferably variant balises are used as reference points.

Preferably, after passing a reference point a new coordinate system is used for position data acquisition.

In a highly preferred variant of the inventive method the tracking units are part of on-board units of an automatic train protection system, e.g. an ETCS-system, a PTC-system or a LZB-system. The on-board units are on-board computing systems, which perform important tasks of an automatic train protection(ATP)-system and contain SIL4-approved components.

Hence the inventive method uses a safe system (e.g. OBU of an ETCS-system) for position determination.

In a special variant of the afore mentioned method the first and second position data is transmitted to a control center of the automatic train protection system, in particular to a radio block center of an ETCS-system, where-  
5     analyzing of the deviation is carried out by means of a central processing unit of the control center. Thus an existing connection for data transmission between on-board units and control center, e.g. via GSM-R, can be used. Analyzing of the deviation can comprise determination of the  
10     distance and the comparison of the determined distance with the reference value.

In an alternative variant the position data of the first carriage is transmitted to the second carriage wherein the determination of the distance and the analyzing of the deviation is carried out by means of an on-board unit of the  
15     second carriage and/or that the position data of the second carriage is transmitted to the first carriage, wherein the analyzing of the deviation is carried out by means of the on-board unit of the first carriage. Here the train integrity is controlled by means of the train itself (train based integrity supervision). The tracking unit to which the position data of the other track-  
20     ing unit is transmitted acts as a "supervising unit", whereas the other tracking unit acts as "slave unit". For this variant no communication with a control center is required. Yet, a safe connection for data transmission between the on-board units is required. Preferably the data transmission is carried out wireless. But also transmission via a wired connection is possible.

25     Generally the train comprises more than two carriages, wherein further carriages are located between the first and the second carriage. It is preferred that the first carriage is the front carriage, in particular a locomotive, and the second carriage is the rear carriage, in particular a locomotive, of the train. Generally the tracking units are installed within the carriage at a fixed  
30     offset to the front end and the rear end of the train respectively. Preferably

during acquisition of the position data said offsets are considered, thus that the determined distance complies with the train length.

In a preferred variant an alert is initiated in case analyzing of the deviation result is a loss of train integrity. Also an emergency stop can be initiated.

- 5 Most preferably movement authority is denied in case analyzing of the deviation result is a loss of train integrity.

Since during acceleration and deceleration the distance between neighboring carriages of the train may vary slightly ("train length oscillation"), an alert is preferably initiated not until the deviation exceeds a predetermined value, in particular 1% of the reference value. Thus, initiating an alert/emergency stop and/or denying movement authority due to "train length oscillation" can be avoided.

In a special variant the reference value is the position value previously determined by having carried out steps a) – c).

- 15 The invention also concerns a usage of on-board units of an automatic train protection system for supervision of train integrity, wherein a first on-board unit is installed on-board of the first carriage and comprises a first tracking unit and a second on-board unit is installed on-board of the second carriage and comprises a second tracking unit.

- 20 The inventive idea is to realize the train integrity supervision by having two tracking units, one on the front side and one on the back side of the train. Thus no special train integrity equipment is necessary. The principle is based on using already existing or otherwise used safe localization service of the two tracking units in order to supervise train integrity. The inventive method can advantageously be used for example for freight trains with one pull and one push locomotive, for rail car trains, push-pull trains with a control car and for trains with a locomotive on the front side and a positioning tender on the rear side.

The inventive method allows safe determination of two positions (front end and rear end of a train) with defined safety integrity levels and confidence intervals by using existing on-board equipment, independent from the type of sensor data and without requiring a two-dimensional map or additional train integrity equipment. The inventive method is compatible for a wide range of existing trains, even for old carriages and freight trains.

Further advantages can be extracted from the description and the enclosed drawing. The features mentioned above and below can be used in accordance with the invention either individually or collectively in any combination. The embodiments mentioned are not to be understood as exhaustive enumeration but rather have exemplary character for the description of the invention.

### Drawings

The invention is shown in the drawing.

- Fig. 1 shows the process of the basic method steps of the inventive method.
- Fig. 2 shows an installation for carrying out a first variant of the inventive method, wherein train integrity is determined by an external control center.
- Fig. 3 shows an installation for carrying out a second variant of the inventive method with train based integrity supervision.

**Fig. 1** shows the basic method steps of the inventive method. First (front end) position data **P1** of a first carriage **C1** of a train **T** and second (rear end) position data **P2** of a second carriage **C2** of the train **T** are determined via a first tracking unit **T1** and a second tracking unit **T2** (see **Fig. 2** and **Fig. 3**). The tracking units **T1**, **T2** are preferably mounted in undividable parts of train **T**, e.g. locomotives. Any tracking system can be used, e.g.

Doppler radar system, optical fibers, GPS, inertial sensor systems, wheel pulse transducer etc. First position data P1 (also possible: first position data P1 added to a reference value  $\mathbf{RV} = \mathbf{RV}(L)$ , e.g. the length L of the train) and/or second position data P2 (also possible: second position data P1 added to a reference value RV, e.g. length L of the train) are transmitted to a processing unit **CPU**.

A deviation  $\Delta$  between the reference value RV (here: length L of the train) and a position value  $\mathbf{PV} = \mathbf{PV}(P1, P2)$  (here: the distance **D** between the first position P1 and the second position P2) is calculated along a rail route of the train, e.g. by subtracting rail route coordinate system related first and second position data P1, P2 and comparing it with the length L of the train T. Instead of second position data P2 only the second tracking unit T2 may also transmit the data in which a tolerable threshold GW is included (e.g.  $P2+L+GW$ ). In order to get rail route coordinate system related position data it may be necessary to convert the detected (preliminary) position data (e.g. GPS data) in order to relate the position data with a rail route coordinate system.

Analyzing the deviation  $\Delta$  may comprise checking whether distance D corresponds within a reachable accuracy ( $\pm$  threshold **GW**) to the length L of the train T (in case offsets of the tracking units T1, T2 to the front/rear end of the train are considered). In case the deviation  $\Delta$  of the determined distance D and the reference value L exceeds the specific threshold GW loss of integrity is detected.

Alternatively analyzing the deviation  $\Delta$  may comprise checking whether the following condition is satisfied:  $P2+L+GW > P1 > P2+L-GW$ .

Another possibility for analyzing the deviation  $\Delta$  is that both tracking units determine third position data P3 by applying an operator which is specific for the tracking units:  $P3=K1(P1,L)=K2(P2,L)$ . In case of  $P3 = P2$  this results in  $K1(P1,L)=P1-L$  and  $K2(P2) = P2$ .

It is also possible that each tracking unit P1, P2 determines expected position data of the respective other tracking unit T1, T2, and transmits the expected position data to the other tracking unit.

In Fig. 2 and Fig. 3 the required components are shown. The train T with front carriage C1 and rear carriage C2 is to be supervised with respect to train integrity. A first on-board-unit **OBU1** is provided in the front carriage C1 and a second on-board-unit **OBU2** is provided in the rear carriage C2, wherein the first on-board-unit OBU1 is equipped with a first tracking unit **T1** and the second on-board-unit OBU2 is equipped with a second tracking unit **T2**. The tracking units T1, T2 do not necessarily have to be mounted on a locomotive; each kind of rolling stock that allows installation of the tracking units T1, T2 with its sensors is sufficient. A minimalistic solution could be some kind of vehicle with at least one axle and only the tracking unit T1, T2 with its sensors and the according communication system installed on it. In order to realize the inventive train integrity supervision function, a safe communication is required to transmit position data P1, P2.

Although the inventive idea is shown and described in the following based on an ETCS-system, it is not limited to the ETCS-system. In principle the inventive idea can be adapted to all kind of systems including a safe position determination (e.g. ATP-systems) that have a save positioning function implemented within its on-board unit. In the following the examples and semantics are related to the ETCS-standard. Within this standard the train integrity supervision can be realized as follows: The first on-board unit OBU1 (as shown in Figures 2 and 3) is in mode "FULL SUPERVISION". The second on-board unit OBU2 is in mode "SLEEPING". This guarantees that the second on-board unit OBU2 still performs the positioning function.

**Fig. 2** shows a configuration in which supervision is carried out via a control center **RBC**. Position data P1, P2 are transmitted from the tracking units T1, T2 to a central processing unit **CPU** of a control center **RBC** via a mobile network **GSM-R** of the ETCS-system. According to Fig. 2 GSM-R standard is

used as transport layer as this is specified in the UNISIG for the connection between RBC and OBU. Yet, the shown variant also works with other transport layers such as GPRS or UMTS. This variant requires no changes within the on-board units OBU1, OBU2, but some extensions in the control center RBC (supervision, error response). Thus it is compatible to ETCS compliant on-board units. In case of detecting a loss of integrity the control center RBC will give no movement authority any more to the first on-board unit OBU1. This will cause the first on-board unit OBU1 to change into mode "TRIP", which is a safe state.

**Fig. 3** shows a configuration in which train integrity supervision is carried out on the train T directly. For this variant a separate communication channel **CH** between the two on-board units OBU1, OBU2 is needed. Fig. 2 shows a concept for a wireless connection. Position data P2 of the second tracking unit T2 is transmitted to the first ("FULL SUPERVISION") on-board unit OBU1 via the communication channel CH.

The protocol used for the transmission channel CH should be compliant to EN50159 for category 3 networks. As such protocols contain timeliness supervision an interruption of the communication will be disclosed in time. In case of either losing the connection between the two on-board units OBU1, OBU2 or discovering a loss of integrity as described above ( $\Delta$  exceeds threshold GW) the first on-board unit OBU1 changes to mode "SYSTEM FAILURE" in order to reach a safe state. This transmission protocol and the supervision functionality are implemented within the on-board units OBU1, OBU2 and are out of scope of the existing ETCS standard.

Both variants use safe tracking units which may already be used by an automatic train protection system. Position data of the front end and the rear end of the train are determined by using distance measurement along a rail route coordinate system. In order to enhance availability and to ensure high safety level each tracking unit preferably uses a diverse measuring principle

by using different types of position sensors. The inventive method enables supervision of train integrity on SIL4-level.

**What is claimed is:**

1. Method for safe supervising train integrity at SIL4-level, the train comprising a first carriage and a second carriage, the method comprising:

5 a) acquiring first position data of the first carriage via a first SIL4-proved tracking unit which is installed on-board of the first carriage and acquiring second position data of the second carriage via a second SIL4-proved tracking unit which is installed on-board of the second carriage, wherein the position data, is related to a  
10 rail route coordinate system and is determined via distance measurement along a rail route coordinate system with reference to at least one reference point on a rail route;

b) determining a deviation  $\Delta$  between a reference value which depends on the length L of the train and a position value which is  
15 determined by subtraction of the first and the second rail route coordinate system related position data;

c) detecting whether train integrity is given by analyzing the deviation;

d) repeating steps a) through c);

20 wherein tracking units are part of on-board units of an automatic train protection system; wherein each tracking unit determines expected position data of the respective other tracking unit and transmits the expected position data to the other tracking unit and wherein the first carriage is the front carriage, and the second carriage  
25 is the rear carriage of the train.

2. Method according to claim 1, characterized in that on-board units of an automatic train protection system are used for supervision of train integrity, wherein a first onboard unit is installed on-board of the first carriage and comprises the first tracking unit and a second

on-board unit is installed on-board of the second carriage and comprises the second tracking unit.

3. Method according to any one of claims 1-2, characterized in that balises are used as reference points.
- 5 4. Method according to any one of claims 1-3, characterized in that first and second position data are transmitted to a control center of the automatic train protection system, wherein the analyzing of the deviation is carried out by means of a central processing unit of the control center.
- 10 5. Method according to claim 4, wherein the first and second position data are transmitted to a radio block center of an ETCS-system.
6. Method according to any one of claims 1-5, characterized in that the position data of the first carriage is transmitted to an on-board unit of the second carriage wherein the analyzing of the deviation is carried out by means of the on-board unit of the second carriage and/or that the position data of the second carriage is transmitted to the first carriage, wherein the analyzing of the deviation is carried out by means of the on-board unit of the first carriage.
- 15 6. Method according to any one of claims 1-5, characterized in that the position data of the first carriage is transmitted to an on-board unit of the second carriage wherein the analyzing of the deviation is carried out by means of the on-board unit of the second carriage and/or that the position data of the second carriage is transmitted to the first carriage, wherein the analyzing of the deviation is carried out by means of the on-board unit of the first carriage.
7. Method according to claim 1, wherein the front carriage and/or the rear carriage is a locomotive.
- 20 7. Method according to claim 1, wherein the front carriage and/or the rear carriage is a locomotive.
8. Method according to any one of claims 1-7, characterized in that an alert is initiated in case analyzing of the deviation result is a loss of train integrity.
9. Method according to any one of claims 1-8, characterized in that movement authority is denied in case analyzing of the deviation result is a loss of train integrity.
- 25 9. Method according to any one of claims 1-8, characterized in that movement authority is denied in case analyzing of the deviation result is a loss of train integrity.

10. Method according to any one of claims 1-9, characterized in that the reference value is the position value previously determined by having carried out steps a) – c).

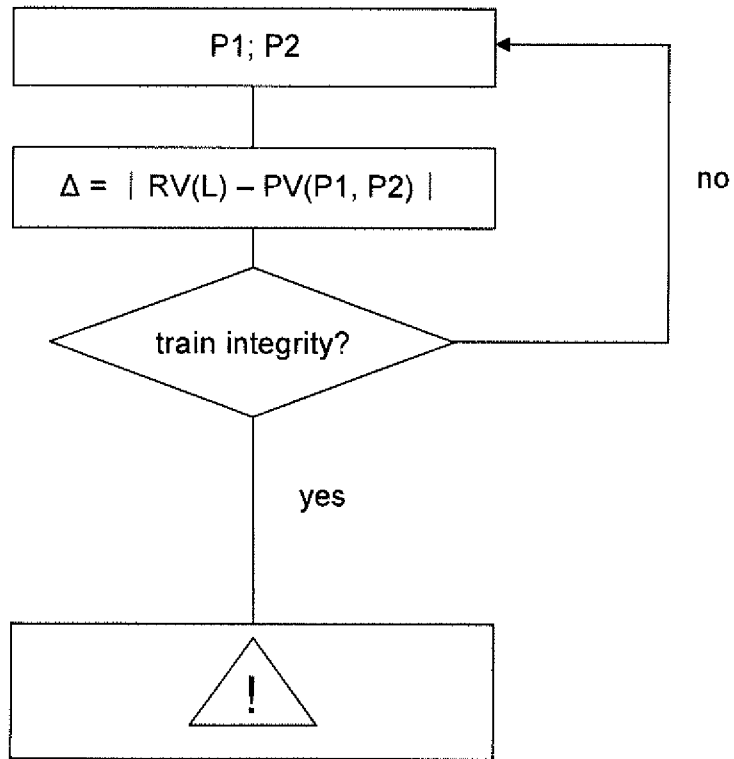

Fig. 1

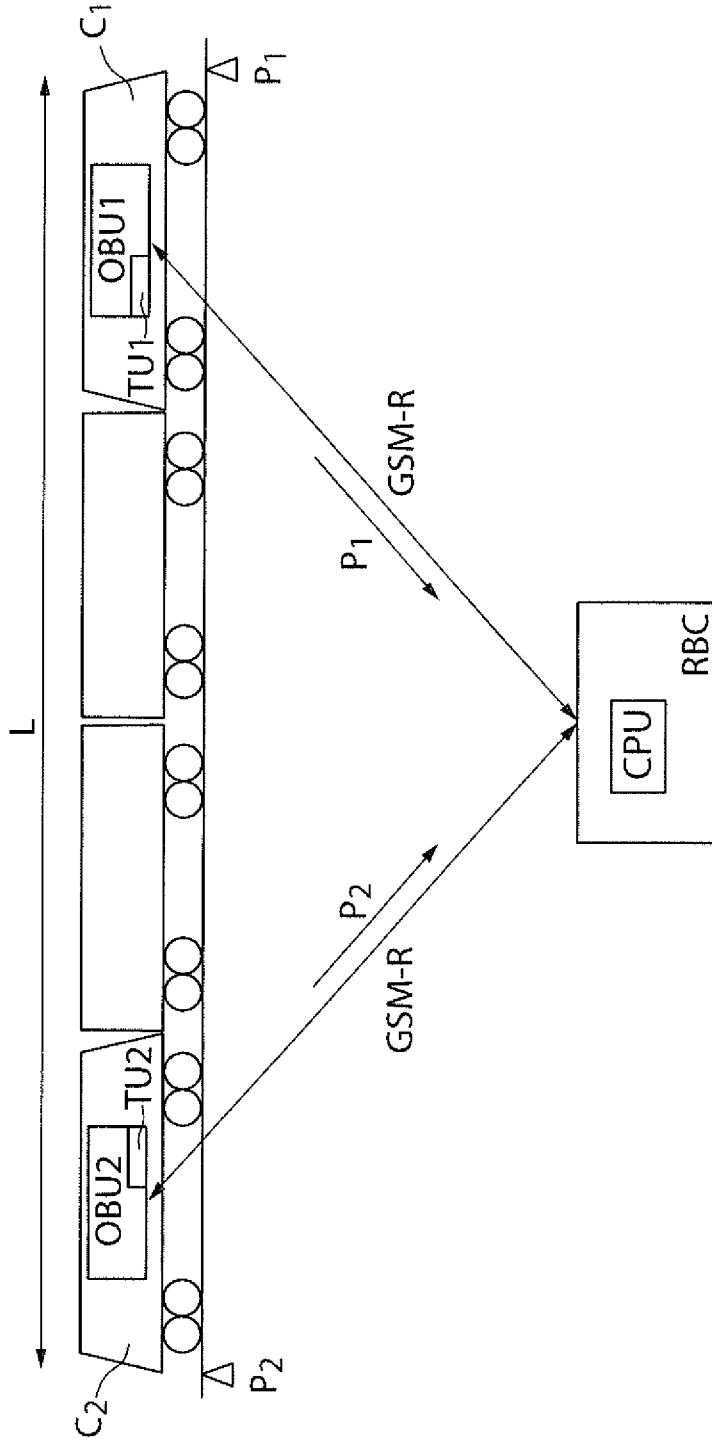

Fig. 2

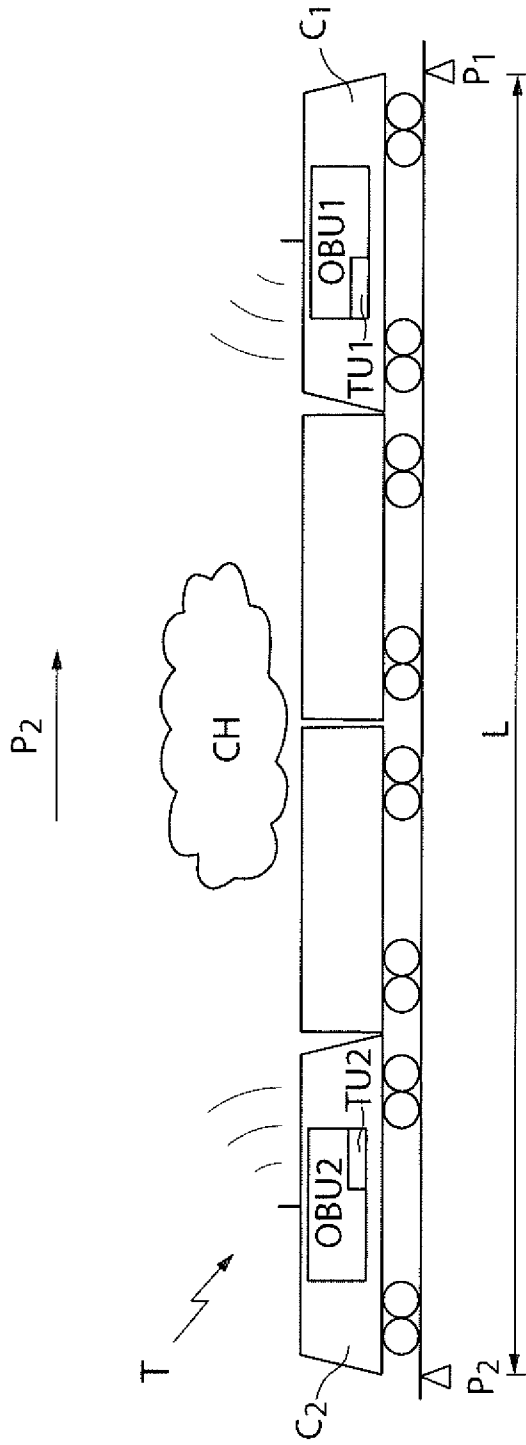

Fig. 3

