



(11) **EP 1 837 451 A3**

(12) **EUROPEAN PATENT APPLICATION**

(88) Date of publication A3:  
**04.06.2008 Bulletin 2008/23**

(51) Int Cl.:  
**E04C 3/292<sup>(2006.01)</sup>**

(43) Date of publication A2:  
**26.09.2007 Bulletin 2007/39**

(21) Application number: **07250686.8**

(22) Date of filing: **20.02.2007**

(84) Designated Contracting States:  
**AT BE BG CH CY CZ DE DK EE ES FI FR GB GR HU IE IS IT LI LT LU LV MC NL PL PT RO SE SI SK TR**  
 Designated Extension States:  
**AL BA HR MK RS**

(71) Applicant: **GANG-NAIL SYSTEMS LIMITED**  
**Aldershot,**  
**Hampshire GU12 4XG (GB)**

(72) Inventor: **Baron, Paul**  
**Surrey GU10 4 BT (GB)**

(30) Priority: **23.03.2006 GB 0605819**

(74) Representative: **Roberts, David Leslie et al**  
**Nash Matthews**  
**90-92 Regent Street**  
**Cambridge CB2 1DP (GB)**

(54) **Joists**

(57) A joist (7) has a metal member providing a web (10) and having an upper surface (11) bonded by adhesive to an upper timber chord (15) and a lower surface (12) bonded by adhesive to a lower timber chord (16).

The inherent stiffness of the metal web, and the location of the upper and lower chords at distances spaced from the neutral axis of the joist, imparts a substantial resistance to bending.

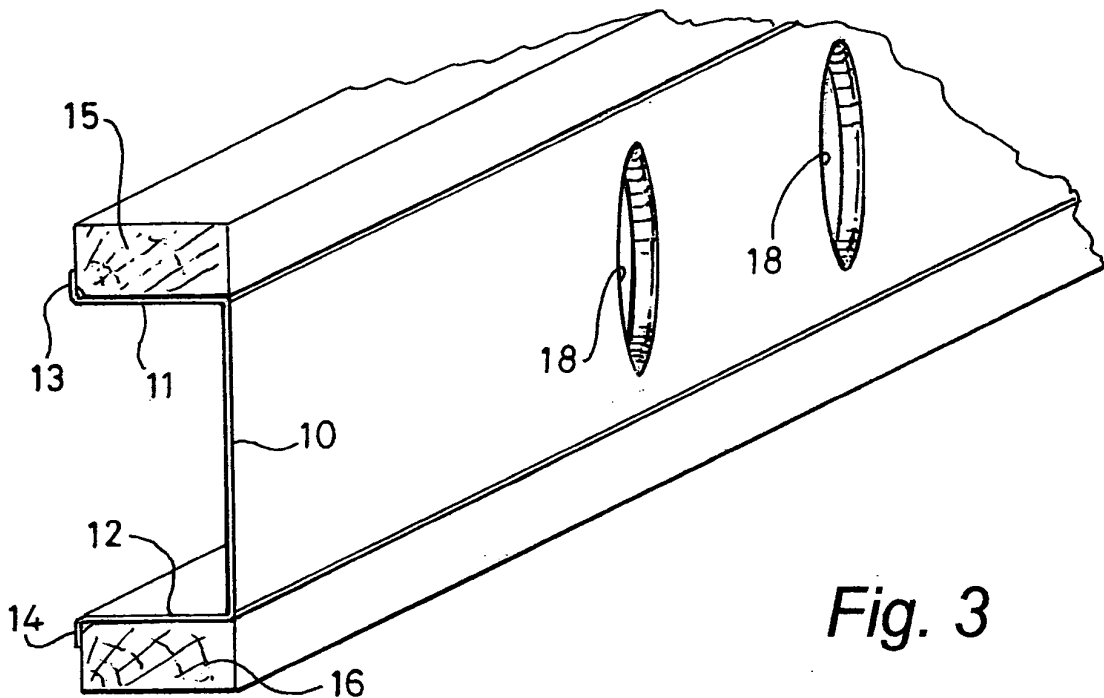

**Fig. 3**

**EP 1 837 451 A3**



DOCUMENTS CONSIDERED TO BE RELEVANT			
Category	Citation of document with indication, where appropriate, of relevant passages	Relevant to claim	CLASSIFICATION OF THE APPLICATION (IPC)
X A	US 2002/166306 A1 (WILSON) 14 November 2002 (2002-11-14) * paragraph [0019] - paragraph [0020] * * paragraph [0024]; figures 1,4,5 * -----	1-4,6, 10,11 5,7,8	INV. E04C3/292
X A	DE 79 35 353 U (H. R. NIELSEN) 10 April 1980 (1980-04-10) * page 7, paragraph 1 - paragraph 2; figures 1,5 * -----	1-7,10, 11 8	
X A A	WO 2004/013423 A (J. ANDERSON) 12 February 2004 (2004-02-12) * page 1, line 20 - line 21 * * page 7, paragraph 1 - paragraph 2 * * page 9, line 8 - line 13; figures 2,2a,3a,4c * -----	1-4,6,8, 9,11 5,7	
A	GB 2 270 094 A (BRIG-EEZ INC.) 2 March 1994 (1994-03-02) * figures 3b,4 * -----	1,5,7-9	
A	AU 650 614 B (MAXI-SPAN HOLDINGS) 30 June 1994 (1994-06-30) * figures 4-6 * -----	1,5,7,8	TECHNICAL FIELDS SEARCHED (IPC) E04C E04B
A	US 4 070 845 A (CODY) 31 January 1978 (1978-01-31) * figures 5,7 * -----	1,5,7	
A	US 4 862 667 A (MELLAND) 5 September 1989 (1989-09-05) * figures * -----	1	
The present search report has been drawn up for all claims			
Place of search The Hague		Date of completion of the search 29 April 2008	Examiner Righetti, Roberto
CATEGORY OF CITED DOCUMENTS X : particularly relevant if taken alone Y : particularly relevant if combined with another document of the same category A : technological background O : non-written disclosure P : intermediate document		T : theory or principle underlying the invention E : earlier patent document, but published on, or after the filing date D : document cited in the application L : document cited for other reasons ----- & : member of the same patent family, corresponding document	

4  
EPO FORM 1503 03.02 (P04C01)

**ANNEX TO THE EUROPEAN SEARCH REPORT  
ON EUROPEAN PATENT APPLICATION NO.**

EP 07 25 0686

This annex lists the patent family members relating to the patent documents cited in the above-mentioned European search report.  
The members are as contained in the European Patent Office EDP file on  
The European Patent Office is in no way liable for these particulars which are merely given for the purpose of information.

29-04-2008

Patent document cited in search report		Publication date	Patent family member(s)	Publication date
US 2002166306	A1	14-11-2002	NONE	
-----				
DE 7935353	U	10-04-1980	SE 429667 B	19-09-1983
			SE 7905365 A	19-12-1980
-----				
WO 2004013423	A	12-02-2004	AU 2003274909 A1	23-02-2004
			CA 2494821 A1	12-02-2004
			EP 1543202 A2	22-06-2005
			MX PA05001471 A	30-09-2005
-----				
GB 2270094	A	02-03-1994	CA 2077170 A1	01-03-1994
-----				
AU 650614	B	30-06-1994	NONE	
-----				
US 4070845	A	31-01-1978	CA 1037235 A1	29-08-1978
			US 4034957 A	12-07-1977
-----				
US 4862667	A	05-09-1989	NONE	
-----				