

L. G. HAASE.  
 CONCRETE STRUCTURE.  
 APPLICATION FILED OCT. 7, 1913.

1,087,366.

Patented Feb. 17, 1914.

Fig. 1.

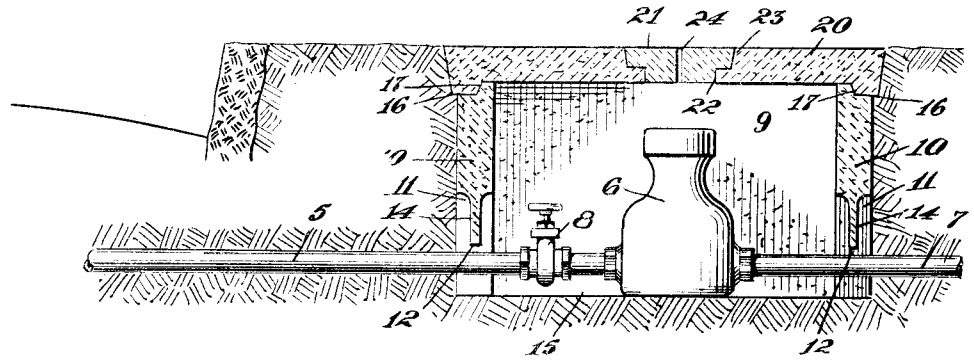

Fig. 2.

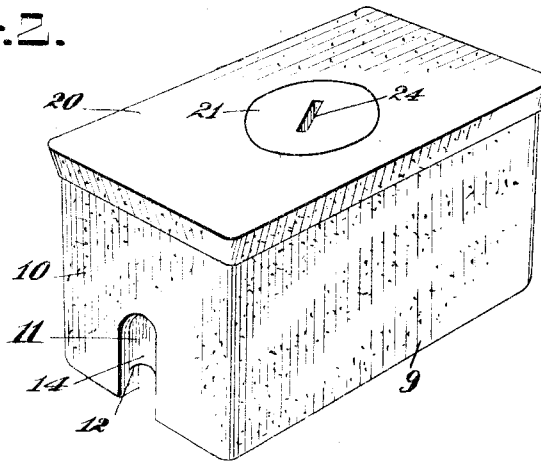
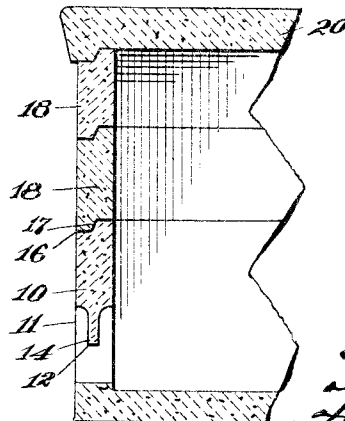

Fig. 3.



WITNESSES:

*A. S. Burns,*  
*Merle Hammond,*

INVENTOR:

*Leo G. Haase*

*50*  
*Harold Haase*  
 Atty.

# UNITED STATES PATENT OFFICE.

LEO G. HAASE, OF PASADENA, CALIFORNIA.

CONCRETE STRUCTURE.

1,087,366.

Specification of Letters Patent.

Patented Feb. 17, 1914.

Application filed October 7, 1913. Serial No. 793,866.

*To all whom it may concern:*

Be it known that I, LEO G. HAASE, a citizen of the United States, residing at Pasadena, in the county of Los Angeles, State of California, have invented new and useful Improvements in Concrete Structures, of which the following is a specification.

This invention relates to improvements in concrete structures and the principal object is to provide an indestructible and easily assembled concrete meter box especially adapted for water service.

It is also an object to provide a concrete box structure which is formed of pipe receiving portions having thin walls at these points adapted to be broken away to a greater or less degree in order to accommodate and fit over piping at different levels.

It is also an object of the invention to provide a concrete meter box adapted to be inserted in the ground and having a cover with beveled edges, whereby the same may be removed without disturbing the ground adjacent thereto.

It is also an object to provide a cover with a hand hole through which the meter may be read which cannot be pried out of position but must be lifted with a special tool and which will not be rolled out.

It is a further object of the invention to provide a meter box which may be built up of a plurality of sections and may have a concrete bottom or not as desired, the sections having rabbeted edges so that water will be shed away from the box.

In the drawings accompanying this specification and forming therewith the application for Letters Patent: Figure 1 is a longitudinal sectional view through the meter box showing a water meter in elevation therein. Fig. 2 is a perspective view of the box as in Fig. 1. Fig. 3 is a transverse detail section of the box showing a plurality of sections and a bottom section formed with a concrete bottom.

The structure forming the subject matter of this invention is especially adapted for use in connection with water or other meters that are set in the ground and such as are commonly employed in house service connections in large cities, and heretofore the boxes commonly used have either been of wood which decays, or iron which sweats and rusts, with the consequent deterioration and obliteration of the metal parts by

incrusting coats upon the glass dials and corrosion of the metal parts.

In carrying out the novel features of the invention a suitable pit is dug in the ground, as clearly shown in Fig. 1, in which the pipe connection 5 leading from the main is shown extending in horizontal direction to which is connected a meter 6, the pipe connection 7 from the meter extending inwardly to be attached to fixtures within a residence or dwelling served by the connections, and surrounding the meter and the valve means 8 are shown the concrete sections 9 preferably rectangular in form and having the end walls 10 recessed centrally of their edges as shown at 11 to a height about one-half of the total height of the section, the wall intermediate of the recesses being cut away below the point 12 to accommodate the normal position of the service pipe, the upper portion of this intermediate wall designated 14 being of such thinness that it is readily broken out to accommodate and make an opening where the pipes are located at a higher level above the floor 15 of the pit. The upper edge of this section is provided with a rabbeted top edge 16, the approximately vertically disposed portion 17 of the rabbet being slanted downwardly and outwardly so that water coming in contact therewith will have a tendency to be shed outside of the walls. Where the pipe connections are of such depth that one section is not sufficient other sections 18 consisting of simple rectangular sections having rabbeted upper and lower edges, as clearly shown in Fig. 3, may be provided.

The top plate 20 is preferably formed as shown with a rabbeted lower edge, the outer portions of this rabbet extending beyond the outer edges of the wall of the section 9 or 18, and preferably inclined from this point outwardly and upwardly so that a grass lawn or a concrete pavement adjoining this latter will not interfere with its removal and will not be chipped upon the removal of the top cover. The cover is also provided with a central opening to provide for the insertion of a hand hole cover 21, this edge being also rabbeted, the lower inner portion being practically vertical, while the portion forming the upper portion of the rabbet is preferably inclined at a greater angle as shown at 23, than the angle

of the edge 22 making it practically impos-  
 sible to insert tools, chisels or other objects  
 to pry the cover out, since the edges will  
 bind, before the smaller cover can be lifted  
 5 from its seat. The inclined edges also pre-  
 vent pebbles or small particles of dirt from  
 preventing a good closure.

In order to lift the cover from the posi-  
 tion a slot 24 is formed therein preferably  
 10 rectangular in form and of narrow width  
 through which a flat hook may be inserted,  
 the hook portion engaging on the lower edge  
 and being supplied to authorized persons  
 whose business requires opening of the meter  
 15 box, the opening being preferably formed  
 in such position that the meter is directly  
 thereunder and the reading of the same may  
 be readily made from this point without re-  
 moving the cover of the box.

The advantage of the concrete cover 21 of  
 the hand hole cover is apparent in that this  
 will not sweat, and moisture will not collect  
 upon the lower edge to drip upon the con-  
 tained apparatus, this dripping water, espe-  
 25 cially when from iron invariably covering  
 over the glass plate of the meter dial and  
 practically preventing the reading of the  
 same without cleansing every time.

What I claim is:

30 1. A concrete meter box, comprising an  
 apertured top, a rectangular section the end  
 walls of which are recessed for a portion of  
 their height, and broken away below said  
 recesses to form openings therein, the aper-

ture in said top having rabbeted edges and 35  
 a slotted cover therefor.

2. A concrete meter box, comprising an  
 apertured top, a plurality of sections having  
 rabbeted edges adapted to be superimposed  
 one upon the other, the lowermost of said 40  
 sections having recessed end walls, the re-  
 cesses extending from the bottom upwardly  
 on both sides of each wall to leave a wall  
 which is readily broken out to form open- 45  
 ings for the passage of service pipes at dif-  
 ferent levels, and a slotted cover adapted to  
 fit within said aperture in said top to form  
 a flush surface therewith.

3. A concrete meter box, comprising an  
 apertured top wall having its outer edges 50  
 tapered from the upper face downwardly  
 and inwardly and overlapping the sides and  
 ends of a section adapted to form a portion  
 of a box, a plurality of sections of similar 55  
 configuration adapted to continue the box to  
 a greater or less depth as required, the low-  
 ermost of said sections having recesses in its  
 walls adapted to so thin the walls that the  
 same may be readily broken out to permit  
 the passage of service pipes therethrough 60  
 without injuring the balance of the section.

In witness that I claim the foregoing I  
 have hereunto subscribed my name this 19th  
 day of September, 1913.

LEO G. HAASE.

Witnesses:

MERLE HAMMOND,  
 MARIE BATTEY.