

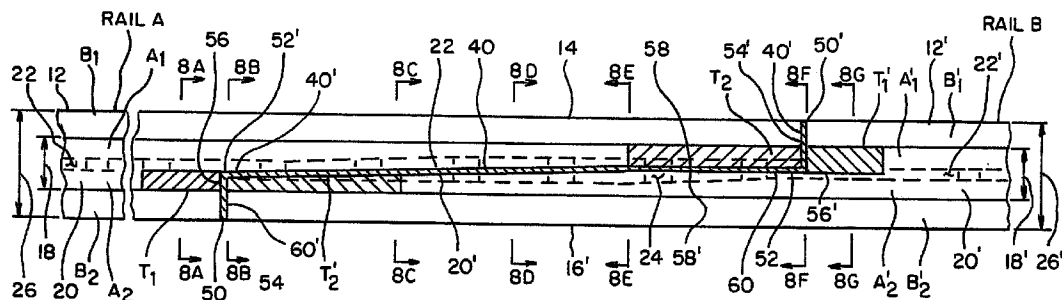

(22) Date de dépôt/Filing Date: 2007/09/14
(41) Mise à la disp. pub./Open to Public Insp.: 2008/03/15
(45) Date de délivrance/Issue Date: 2021/05/04
(62) Demande originale/Original Application: 2 993 736
(30) Priorités/Priorities: 2006/09/15 (US60/844,774);
2007/09/12 (US11/900,635)

(51) Cl.Int./Int.Cl. *E01B 11/54* (2006.01)
(72) Inventeurs/Inventors:
URMSON, WILLIAM T., JR., US;
MOSPAN, JOHN W., US;
REMINGTON, JAMES A., US
(73) Propriétaire/Owner:
KOPPERS DELAWARE, INC., US
(74) Agent: INTEGRAL IP

(54) Titre : JOINT A RECOUVREMENT
(54) Title: LAP JOINT



(57) Abrégé/Abstract:

A rail joint bar for use in an insulated lap joint assembly includes a longitudinal extending body defining a plurality of holes therein for receiving fasteners. The body is bent thus forming a first portion, a second portion spaced from the first portion and an intermediate portion defined therebetween, wherein the first portion and the second portion are substantially parallel to each other and, wherein the intermediate portion of the body is configured to accommodate an increase in thickness of a web section at a point where two railroad rails are joined.

ABSTRACT OF THE INVENTION

A rail joint bar for use in an insulated lap joint assembly includes a longitudinal extending body defining a plurality of holes therein for receiving fasteners. The body is bent thus forming a first portion, a second portion spaced from the first portion and an intermediate portion defined therebetween, wherein the first portion and the second portion are substantially parallel to each other and, wherein the intermediate portion of the body is configured to accommodate an increase in thickness of a web section at a point where two railroad rails are joined.

LAP JOINT

TECHNICAL FIELD

[0001] The present invention relates to the method and apparatus for electrically isolating two adjoining railroad rail sections together and, more particularly, to providing joined insulated rails that are machined.

BACKGROUND

[0002] The rail system, which permits more than one train to travel on one stretch of track of rail, is generally divided into sections or blocks. The purpose of dividing railroad rails of a rail system into sections is to detect the presence of a train on a section of rail at any given time. Each rail section is electrically isolated from all other sections so that a high electrical resistance can be measured over the rail section when no train is present in that section. When a train enters a rail section, the train will short circuit adjacent railroad rails in which the electrical resistance in the rail section drops thereby indicating the presence of a train.

[0003] Railroad rails are generally welded to each other or attached to each other by a steel joint. Fig. 1 shows a typical prior art railroad rail 10 that includes a body 12 having a first side 14 and a second side 16 and defines a head section 18, a web section 22 and a base section 26. The head section 18 having a top surface 20 is connected to the web section 22, which is connected to the base 26. The web section 22 defines at least one slot 24 (shown in phantom) for receiving fasteners.

[0004] In order to electrically isolate adjacent rail sections of a rail system, high-performance, non-metallic joints or steel joints having electrically insulated material bonded to its surface are typically used in conjunction with electrically-insulating material placed between abutting ends of joined railroad rails.

[0005] Fig. 2 shows a prior art rail joint assembly 30 that includes a first railroad rail 32 having an abutting end 33 and a second railroad rail 34 having an abutting end 35. The ends 33, 35 of the respective railroad rails 32, 34 are joined to each other and a rail joint bar 36 is used to hold the two ends 33, 35 in place. A plurality of holes 38 are defined in the rail joint bar 36, where the holes 38 are adapted to receive fasteners, such as a nut and bolt arrangement (not shown), for securing the rail joint bar 36 to the railroad rails 32, 34. Electrically-insulating material 40, such as polyurethane, is sandwiched between the rail ends 33, 35 to

insulate the railroad rails 32, 34 from each other. However, over time the rail wheels will cause the rail ends 33, 35 to deform and/or break apart (referred to in the industry as end batter E shown in Fig. 2), thus causing the railroad rails 32, 34 to contact each other and short out.

[0006] Fig. 3 shows a prior art rail joint arrangement 42 that addresses the problems of deformation and end batter of adjoining insulated railroad rails. Like reference numerals are used for like parts. The arrangement 42 includes two joined railroad rails 32, 34 that have been machine cut, tapered and trimmed to compliment one another (collectively known in the industry as a “Z Cut”). This arrangement 42 spreads the impact load of the train wheels over a longer area thus increasing the Moment of Inertia at a section where the railroad rails 32, 34 are joined. Although the arrangement 42 has a high Moment of Inertia, which can be defined as the capacity of a cross-section to resist bending, this arrangement 42 utilizes non-standard railroad rails having a double thick web section 22 (not shown), such that non-standard rail joint bars have to be used when attaching the railroad rails 32, 34 to each other. The use of non-standard railroad rails and rail joint bars increases the cost for the arrangement 42. The electrically-insulating material 40 has uniform thickness throughout its length and insulates from the top to the bottom of the adjacent railroad rails 32, 34.

SUMMARY OF THE INVENTION

[0007] It is, therefore, an object of the present invention to eliminate the above-mentioned deficiencies by providing a high strength lap joint assembly that utilizes standard railroad rails and other off-the-shelf rail products for electrically isolating two adjoining railroad rail end sections to each other. It is a feature of the present invention to eliminate end batter and to provide a lap joint assembly that is substantially as stiff as a solid railroad rail. It is another feature of the present invention to use bonded rail joints and an adhesive such as an epoxy between the adjoining rail end sections thus increasing the longitudinal bond strength of the lap joint assembly.

[0008] The present invention provides for a lap joint assembly wherein rail end sections of two adjoining railroad rails are machine tapered and trimmed and a method of making the same. The lap joint assembly includes two spaced apart mating railroad rails that are double bent and machine tapered and trimmed to conform in spatial alignment with one another, an electrically-insulating material positioned between the two machined mating railroad rails, and a rail joint bar used for attaching the railroad rail to one another via fasteners.

BRIEF DESCRIPTION OF THE DRAWINGS

- [0009] Fig. 1 is a front elevational view of a typical prior art railroad rail;
- [0010] Fig. 2 is an elevational side view of a prior art rail joint assembly for electrically isolating two adjoining railroad rail end sections;
- [0011] Fig. 3 is a top plan view of a prior art rail joint arrangement for electrically isolating two adjoining railroad rail end sections;
- [0012] Fig. 4 is a top plan view of mating railroad rails, Rails A and B, after bending;
- [0013] Fig. 5 is a top plan view of mating railroad rails shown in Fig. 4, after machining;
- [0014] Fig. 6 is a perspective view of Rail A shown in Fig. 5;
- [0015] Fig. 7 is a top plan view of mating railroad rails, Rails A and B, joined together and with electrically-insulating material positioned therebetween;
- [0016] Figs. 8A-8G show cross-sectional views of mating rail end sections, Rails A and B, taken along Sections 8A, 8B, 8C, 8D, 8E, 8F and 8G of Fig. 7;
- [0017] Fig. 9 is a top plan view of a lap joint assembly made in accordance with the present invention;
- [0018] Fig. 10 is an elevational side view of the lap joint assembly shown in Fig. 9;
- [0019] Fig. 11 is a perspective view of the lap joint assembly shown in Fig. 9;
- [0020] Fig. 12A is an elevational side view of a non-standard rail joint bar according to the present invention for use with the lap joint assembly shown in Fig. 9;
- [0021] Fig. 12B is a top plan view of the rail joint bar shown in Fig. 12A;
- [0022] Fig. 12C is an end view of the rail joint bar shown in Fig. 12A;
- [0023] Fig. 12D is a perspective view of the rail joint bar shown in Fig. 12A;
- [0024] Fig. 13 is a perspective view of a piece of electrically-insulating material for an end post of the lap joint assembly shown in Fig. 9; and
- [0025] Fig. 14 is a top plan view of the lap joint assembly showing the position of traveling of train wheels on Rails A and B (shown in phantom).

DETAILED DESCRIPTION OF THE INVENTION

[0026] For purposes of the description hereinafter, the words “upward” and “downward”, and like spatial terms, if used, shall relate to the described embodiments as oriented in the drawing figures. However, it is to be understood that many alternative variations and embodiments may be assumed except where expressly specified to the contrary. It is also to be understood that the specific devices and embodiments illustrated in the accompanying drawings and described herein are simply exemplary embodiments of the invention.

[0027] Fig. 4 shows mating railroad rail sections, Rails A and B, in a bent position. Rails A and B can be any size or type of standard tee railroad rail 10 as shown in Fig. 1, such as 132-RE, 136-RE and 141-RE rails according to the American Railway Engineering and Maintenance-of-Way Association (AREMA) specifications. Like reference numerals are used for like parts. Referring to Fig. 4, Rail A includes a body 12 having a first side 14 and a second side 16 and defining a head section 18, a web section 22 connected to the head section 18, and a base section 26 connected to the web section 22. The web section 22 is shown in phantom by dashed lines. The head section 18 having a top surface 20 includes a first head portion A₁ and a second head portion A₂, and the base section 26 includes a first base portion B₁ and a second base portion B₂ on each side 14, 16, respectively, of Rail A. Rail B, which is a mirror image of Rail A, has a body 12' with a first side 14 and a second side 16 and includes a head section 18' having a top surface 20' and defining a first head portion A₁' and a second head portion A₂', a base section 26' having a first base portion B₁' and a second base portion B₂' and a web section 22' defined therebetween. The web section 22' is also shown in phantom by dashed lines.

[0028] With continued reference to Fig. 4, the bending of Rails A and B is the first step prior to machining both of the rail sections to compliment each other as shown in Fig. 5. Each of the Rails A and B include two bends (referred to as a double bend). For references purposes, the first bend in Rail A is bent upward in a first direction X away from Rail B, and the first bend in Rail B is bent downward in a second direction X' away from Rail A. The second bend in Rail A is bent downward in the second direction X' toward Rail B and the second bend in Rail B is bent upward in the first direction X toward Rail A, such that the remaining rail sections after the second bend of Rails A and B are substantially parallel to each other.

[0029] Fig. 5 illustrates mating railroad rails, Rails A and B, after they have been machine trimmed and tapered. Also shown in Fig. 5 are the unmachined bent Rails A and B in phantom over the machined Rails A and B. Predetermined portions of the first and second head portions A₁, A₂, the first and second base portions B₁, B₂ and the web section 22 of the body 12 of Rail A are removed. Accordingly, predetermined portions of the first and second head portions A₁', A₂', the first and second base portions B₁', B₂' and the web section 22' of the body 12' of Rail B are likewise removed. The head sections 18, 18' and base sections 26, 26' of Rails A and B are marked according to how the metal is machined trimmed and tapered. Referring to Rail A after machining as shown in Figs. 5 and 6, Rail A includes a first section 46 and a second tapered section 48, wherein the second section 48 has a first end 50 and a second end 52. The first section 46 of Rail A is substantially similar to Rail A before machining occurred, except that a portion of the top surface 20 of the second head portion A₂ tapers downward toward the base section 26 as represented by reference T₁. The removal of the second head and base portions A₂, B₂ of Rail A after machining resulted in the formation of a ledge 54 having a first abutting surface 56 at the first end 50 of the second section 48 of Rail A. Further, a portion of the first base portion B₁ and the first head portion A₁ between the first end 50 and the second end 52 are trimmed, as shown in cross hatch as represented by references C1, C2, respectively. The head section 18 and web section 22 of the second section 48 of Rail A tapers from the first end 50 toward the second end 52, thus defining an intermediate abutting surface 58. The thickness of the web section 22 of the second section 48 of Rail A decreases from the first end 50 to the second end 52. A portion of the top surface 20 of the head section 18 tapers downward toward the second end 52 as represented by reference T₂, wherein the second end 52 defines a second abutting surface 60. Likewise, Rail B is machine trimmed and tapered in the same manner as Rail A in order for Rails A and B to compliment one another when joined, as shown in Fig. 7. Like corresponding reference numerals are used for like parts.

[0030] Fig. 7 illustrates mating railroad rails, Rails A and B, after being joined to each other with electrically-insulating material 40, 40' (such as polyurethane) positioned between the abutting surfaces 56 and 60', 58 and 58', 60 and 56'. The insulating material 40, which is generally rectangular shaped, is positioned between the intermediate abutting surfaces 58 and 58'. Referring to Figs. 6, 7 and 13, the insulating material 40', which corresponds, in general, to the shape of the second end 52 of Rail A, is positioned between the first and second abutting

surfaces 56, 60' and 60, 56' of Rails A and B, respectively,. Referring to Fig. 13, the insulating material 40' includes a body 80 defining an upper portion 82, a lower portion 84 spaced from the upper portion 82 and a web portion 86 connecting the upper portion 82 to the lower portion 84. The upper and lower portions 82, 84, extend in a same direction away from the web portion 86, thus defining a generally C-shaped profile, which is adapted to conform to the profile of first and second abutting surfaces 56, 60' and 60, 56' of Rails A and B, respectively.

[0031] Figs. 8A-8G illustrates cross-sectional views of mating rail sections, Rails A and B, at Sections 8A, 8B, 8C, 8D, 8E, 8F and 8G of Fig. 7 after being joined. The profiles of Rails A and B change over the length of the joined rail sections taking along Sections 8A-8G. As can be seen, Section 8D ends at the midpoint of the mating rails, Rails A and B. As illustrated, Rail A is a more dominant part of the rail from Sections 8A-8C. After Section 8D, where both mating rails, Rails A and B, are essentially equal, the mirror image of Fig. 7 occurs, wherein Rail B is a more dominant part of the rail from Sections 8E-8G.

[0032] Figs. 9-11 show various views of a lap joint assembly 64 made in accordance with the present invention for electrically isolating two railroad rail sections. The assembly 64 includes mating rail sections, Rails A and B, joined to each other with electrically-insulating material 40, 40' sandwiched therebetween, and a pair of rail joint bars 66, 66' attached to each side 14, 16, respectively, of the mating rail sections for securing Rails A and B to each other, via fasteners F. Figs. 12A-12D show a rail joint bar 66 having a longitudinal extending body 68 and defining a plurality of holes 70 for receiving fasteners. Rail joint bar 66 is shaped similar to a standard prior art rail joint bar 36 as shown in Fig. 2, except that the body 68 is bent thus forming a first portion 72, a second portion 74 spaced from or offset from the first portion 72 and an intermediate portion 76 defined therebetween, wherein the first portion 72 and the second portion 74 are substantially parallel to each other as shown in Fig. 12B. Standard prior art rail joint bars are unbent, that is, they do not include the offset described above. The thickness of the joined web sections 22, 22' of Rails A and B (shown as dashed lines) is greater than the thickness of the web section of the individual railroad rails before machining as shown in Fig. 7. Referring to Figs. 7, 9 and 11, this increase in thickness occurs at a point where the first abutting surface 56 of Rail A and the second abutting surface 60' of Rail B meet on the second side 16 of Rails A and B. The bend or intermediate portion 76 of the rail joint bar 66 is adapted or configured to accommodate the increase in thickness at this

point, such that the second portion 74 is attached to the second side 16 of the first section 46 of Rail A, and the first portion 72 is attached to a portion of the second section 48' of Rail B. Likewise, the increase in web thickness occurs again at a point where the first abutting surface 56' of Rail B and the second abutting surface 60 of Rail A meet on the first side 14 of Rails A and B, wherein rail joint bar 66' is used for attachment. The rail joint bars 66, 66' may be attached to each side 14, 16 of the mating rail sections, Rails A and B, via fasteners F such as a nut and bolt arrangement. Further, rail joint bars 80, 80', similar to that as shown in Fig. 2, except the rail joints 80, 80' may have a slight bow and preferably are non-insulated, may optionally be used on opposing sides of rail joint bars 66, 66', respectively, for further securing mating rail sections, Rails A and B to each other. Referring to Figs. 9 and 14, for example, the rail joint bar 66 is positioned on the second side 16 on a portion of joined Rails A and B, and rail joint bar 80 is positioned on the first side 14 of Rail A opposite rail joint bar 66. The rail joint bars 66, 66' and 80, 80' are preferably made of metal and bonded to rail using epoxy. Rail joint bars 66, 66' are electrically insulated from their respective railroad rails via an electrical insulator, such as a fiberglass sheath sandwiched between the rail joint bars 66, 66' and the respective rail ends. Rail joint bars 80, 80' do not need an insulated sheath. Because of the shape of rail joint bars 66, 66' and the large bond area, the strength of the lap joint assembly 64 is substantially increased. For example, it is believed that there is approximately 58% more bond strength (e.g., tensile strength) using bonded rail joint bars 66, 66' because of the overlap of the two rail ends. An adhesive can also be used to bond the electrically-insulating material 40, 40' that is positioned between the abutting surfaces 56 and 60', 58 and 58', 60 and 56' of Rails A and B, thus also increasing the strength of the lap joint assembly 64.

[0033] Fig. 14 shows the travel of the train wheels W (shown in phantom by dashed lines) on the top surfaces 20, 20' of the head sections 18, 18' of Rails A and B of the lap joint assembly 64. As the train travels from Rail A to Rail B, the tapered portions T₁, T₂' of Rails A and B form a recess portion that causes the weight of train wheels to shift, primarily on Rail A where the web section 22 is thicker. Because the train wheels do not contact the tapered portions T₁, T₂' or recess portion of each of the Rails A and B, the impact load of the train wheels shift to a portion where the web section is at its thickest. As the train wheels pass tapered portion T₂' of Rail B, the load of the train wheels begins to shift to both Rails A and B. As the train wheel reach tapered portion T₁ of Rail A, the load of the train wheels shifts primarily to Rail B where the web section 22' is thicker. The lap joint assembly 64 results in a

stronger and longer lasting rail joint assembly having a high Moment of Inertia, thereby reducing the end batter and deformation caused by the train wheels.

[0034] The present invention also provides for a method of manufacturing joined insulated rail sections, Rails A and B, that are machine tapered and trimmed, wherein the abutting rail sections are electrically isolated from one another. First, as previously described, Rails A and B are double bent to compliment each other. Second, the head sections 18, 18' and base sections 26, 26' of both rails are measured and marked according to how the metal is to be trimmed by a machine. Third, predetermined portions of the first and second head portions A₁, A₂, the first and second base portions B₁, B₂ and the web section 22 of the body 12 of Rail A are removed. Accordingly, predetermined portions of the first and second head portions A₁', A₂', the first and second base portions B₁', B₂' and the web section 22' of the body 12' of Rail B are likewise removed. Fourth, after trimming/tapering, an electrically-insulating material 40, such as a fiberglass sheath bonded with an epoxy is placed along the length of the intermediate abutting surfaces 58, 58'. Also, electrically-insulating material 40', such as a polyurethane or fiberglass sheath, is placed between abutting surfaces 56, 60' and 60, 56', respectively, of Rails A and B. The insulating material 40' can also be secured to the rail surfaces with epoxy. The thickness of the electrically-insulating material 40 and 40' may be the same or different. Lastly, Rails A and B are mechanically connected to each other and/or joint bars 66, 66' via fasteners F passing through bolt holes through each rail's respective web sections 22, 22'. The fasteners F can be any known fasteners in the art for joining two railroad rails together such as a nut and bolt arrangement. In addition, electrically-insulating material may also be positioned between the rail joint bars 66, 66' and Rails A and B for electrical isolation of the rail sections. As will be readily appreciated by those skilled in the art, the method of manufacturing and of assembling Rails A and B can repeat ad infinitum in order to provide railroad rails of varying lengths.

[0035] Further, it will be readily appreciated by those skilled in the art that modification may be made to the invention without departing from the concepts disclosed in the foregoing description. Accordingly, the particular embodiments described in detail herein are illustrative only and are not limiting to the scope of the invention, which is to be given the full breadth of the appended claims and any and all equivalents thereof.

What is claimed is:

1. An electrically-insulating material for use in an insulated lap joint assembly, the insulating material comprising:

a body defining an upper portion having a first end and a second end, a lower portion having a first end and a second end, and a web portion connecting the upper portion to the lower portion, the lower portion is spaced from the upper portion, wherein the first end of the upper portion extends from the web portion to the second end of the upper portion, wherein the first end of the lower portion extends from the web portion to the second end of the lower portion, and wherein the upper portion and the lower portion extend in a same direction away from the web portion, thereby defining a generally C-shaped profile.

2. The electrically-insulating material of claim 1, wherein the upper portion is configured to conform to an abutting surface of a head section of a rail, and the lower portion is configured to conform to an abutting surface of a base section of a rail.

3. A lap joint assembly comprising:

a first railroad rail;

a second railroad rail configured to be joined to the first railroad rail, wherein each railroad rail having a first side and a second side comprises a body defining a first section and a tapered second section having a first end and a second end, the first section and the second section each defines a head section, a web section depending from the head section, and a base section depending from the web section, wherein a portion of the base section, the web section, and the head section of the second section defines a first abutting surface at the first end, an intermediate abutting surface that tapers from the first end to the second end, and a second abutting surface at the second end, the first abutting surface of the first railroad rail is configured to abut against the second abutting surface of the second railroad rail and the second abutting surface of the first railroad rail is configured to abut against the first abutting surface of the second railroad rail; and

an electrically-insulating material as recited in claim 1, the electrically-insulating material configured to conform to at least one of the first and second abutting surfaces of the first railroad rail.

4. The lap joint assembly of claim 3, wherein a portion of a top surface of the head section of the second section of each of the first and second railroad rails tapers downward toward the base section ending at the second end of the second section to define a recess.

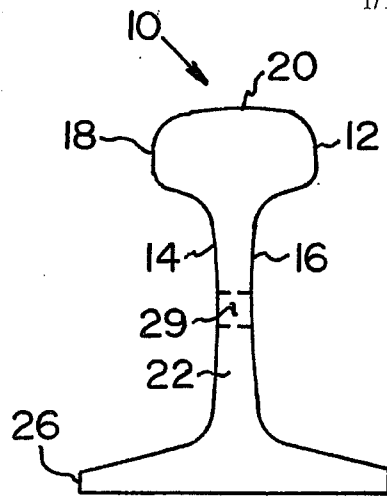

FIG. 1 (PRIOR ART)

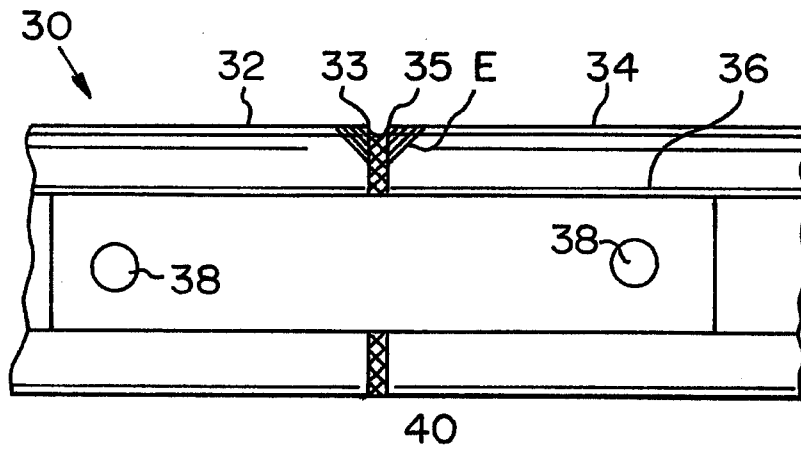

FIG. 2 (PRIOR ART)

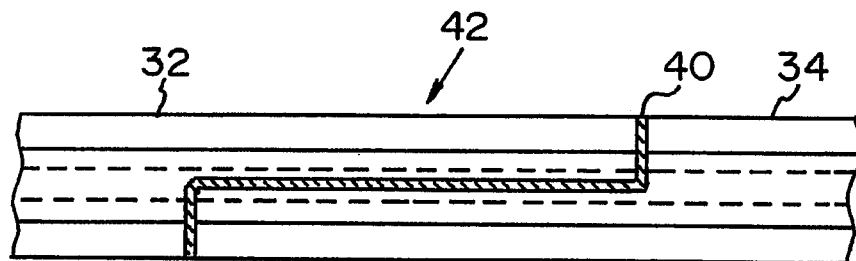

FIG. 3 (PRIOR ART)

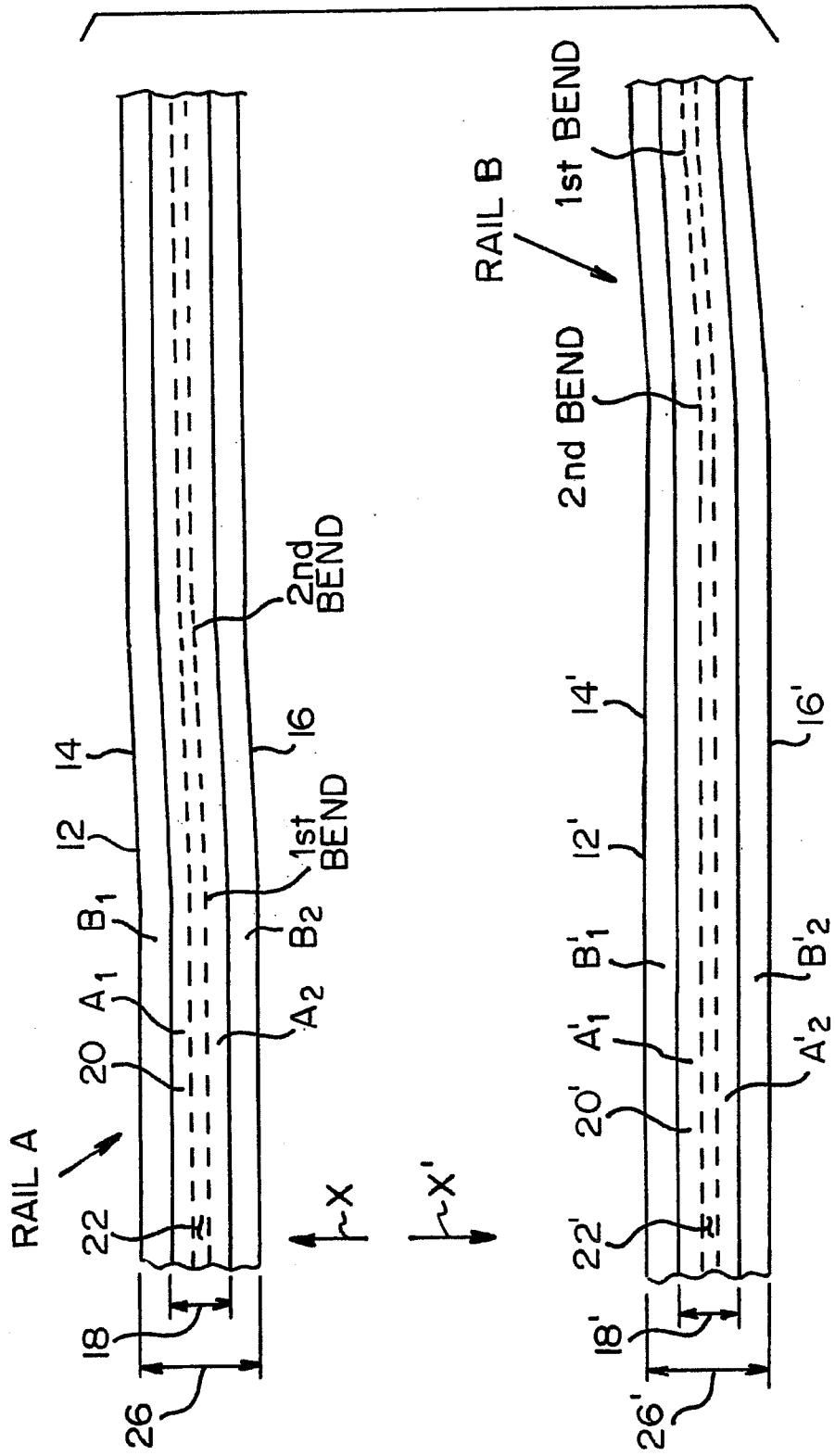

FIG.4

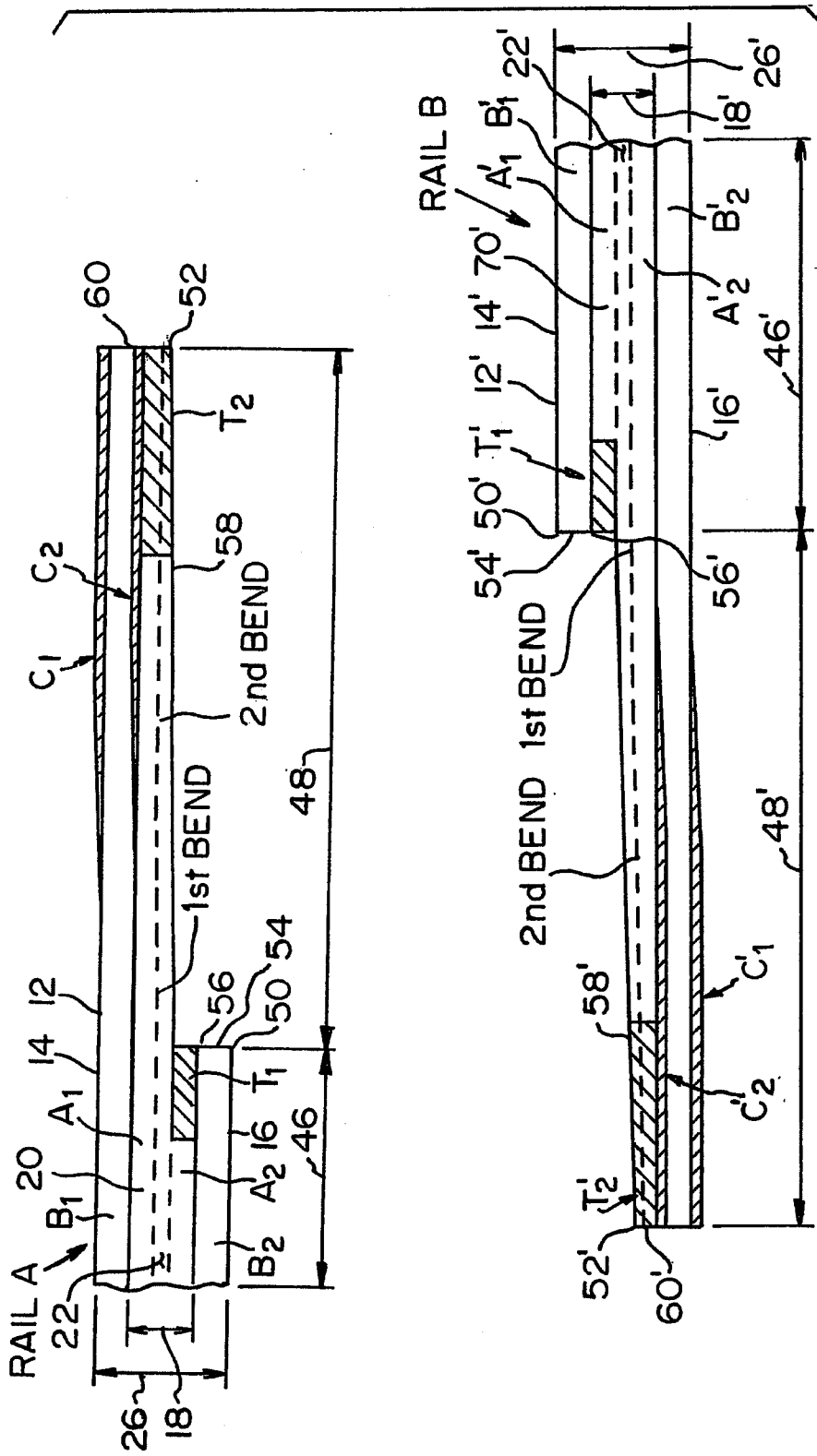

FIG. 5

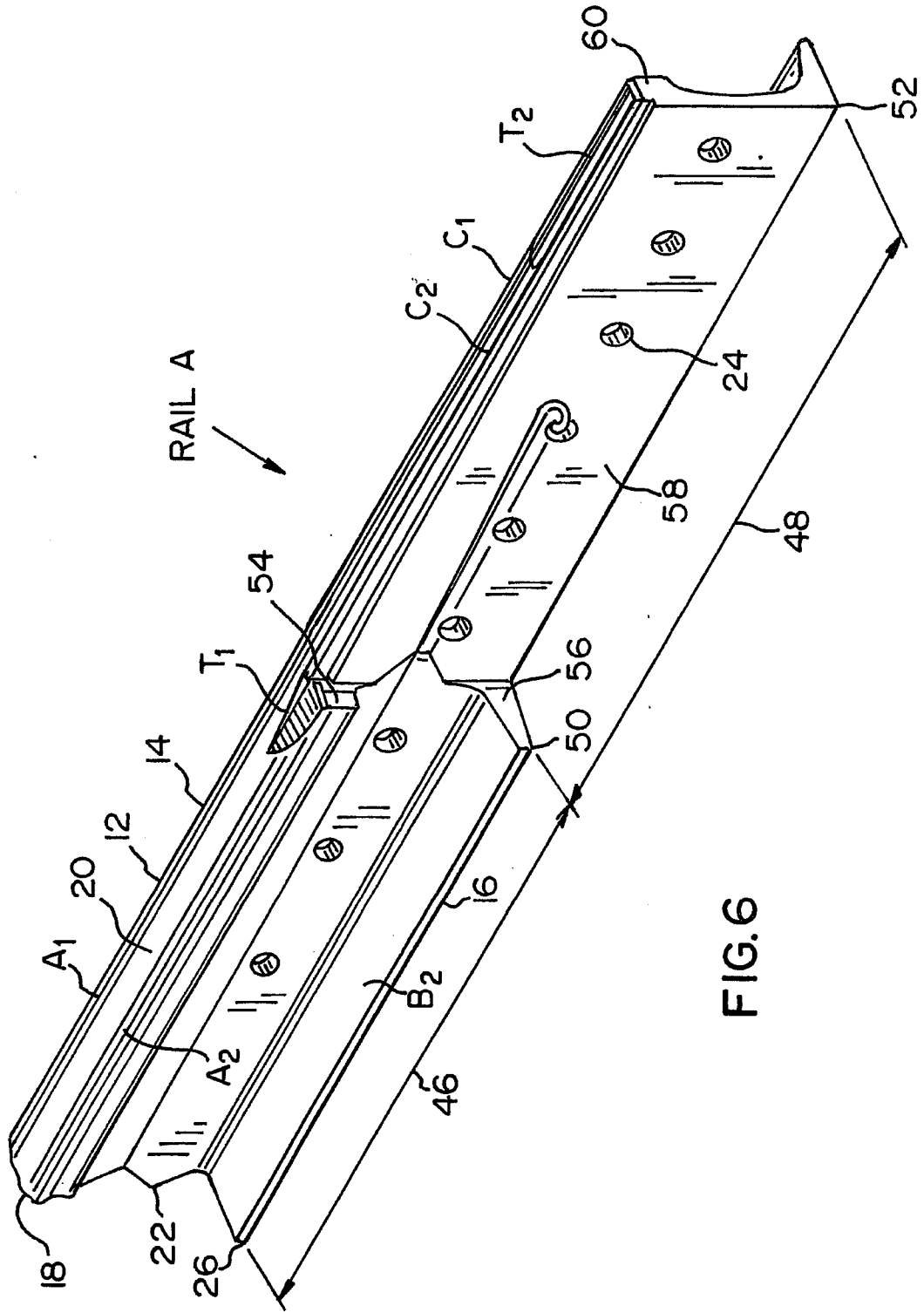

FIG.6

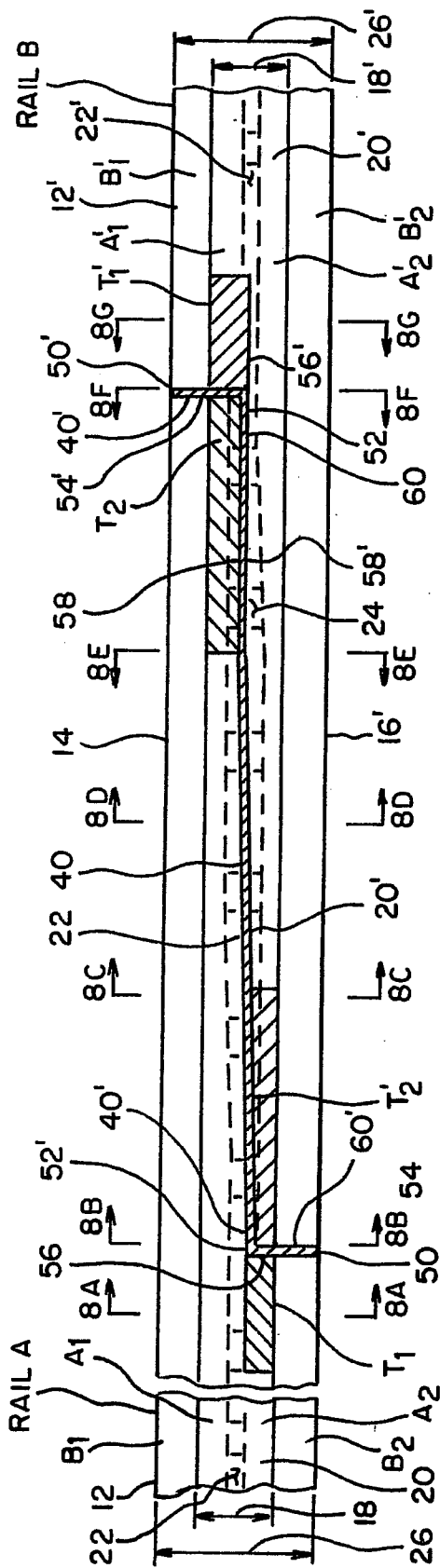

FIG. 7

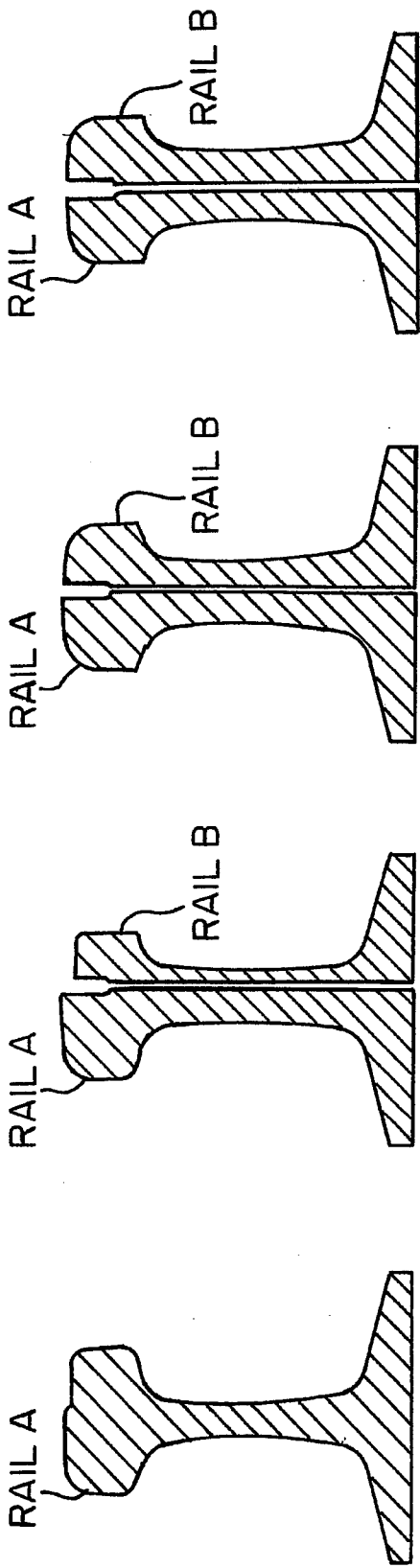

FIG. 8A FIG. 8B FIG. 8C FIG. 8D

6/12

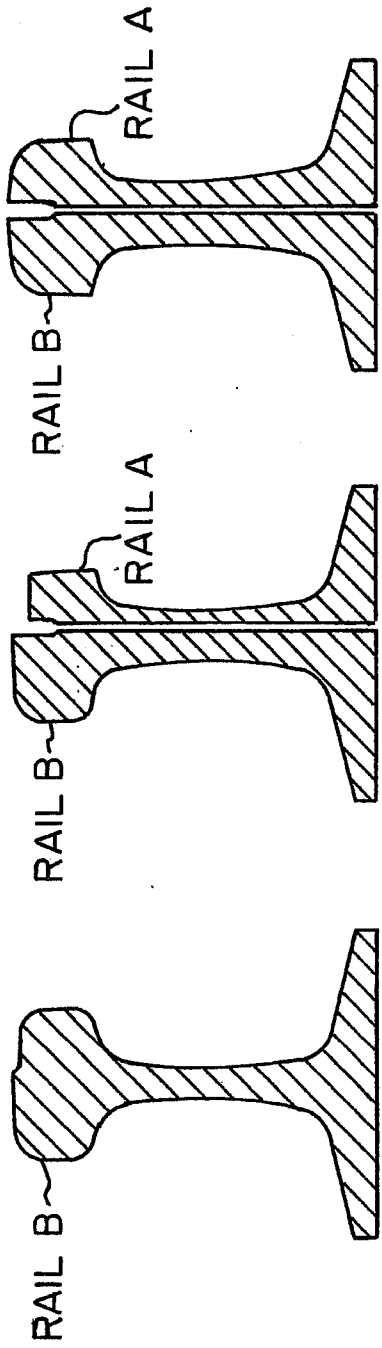

FIG. 8E FIG. 8F FIG. 8G FIG. 8H

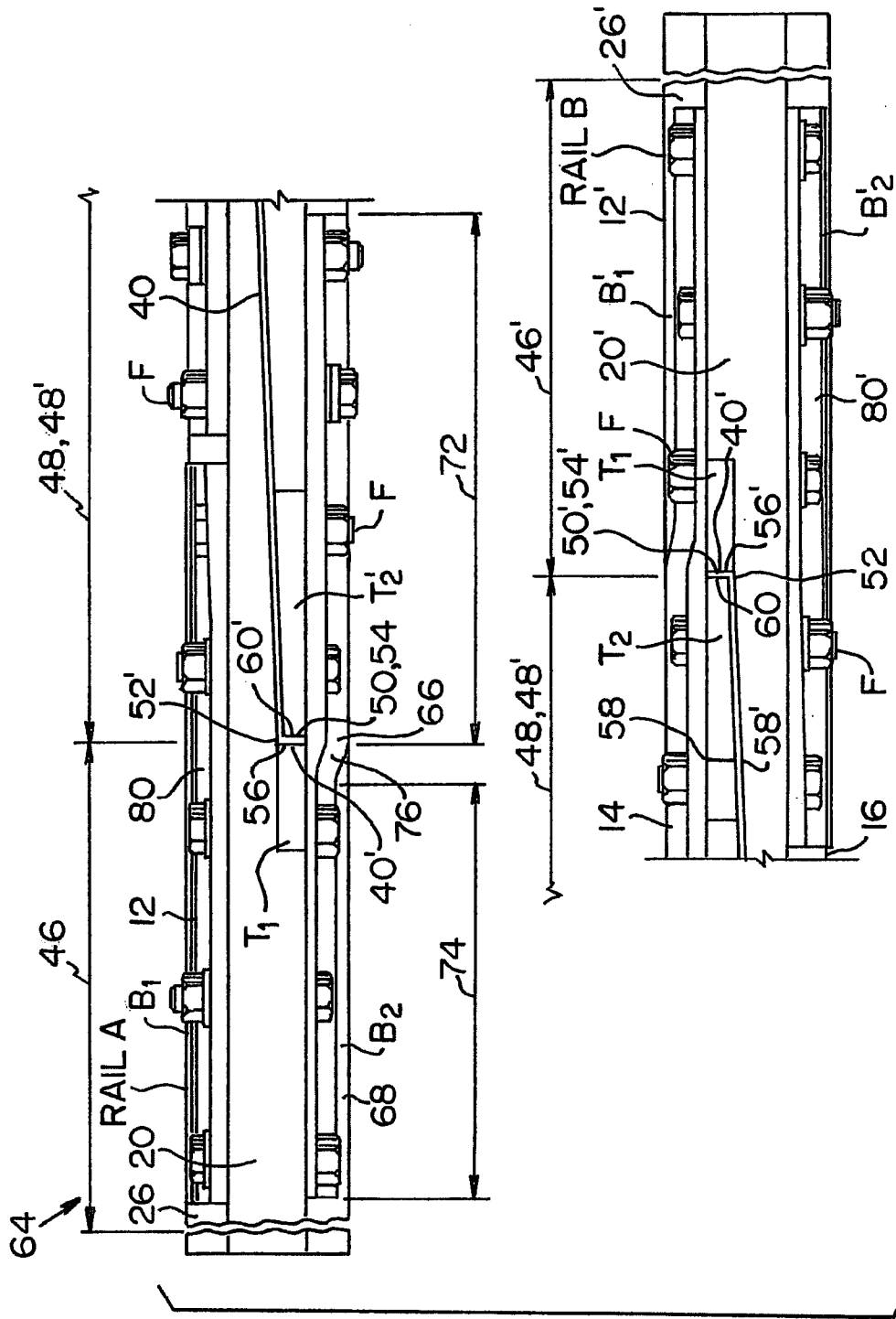

FIG. 9

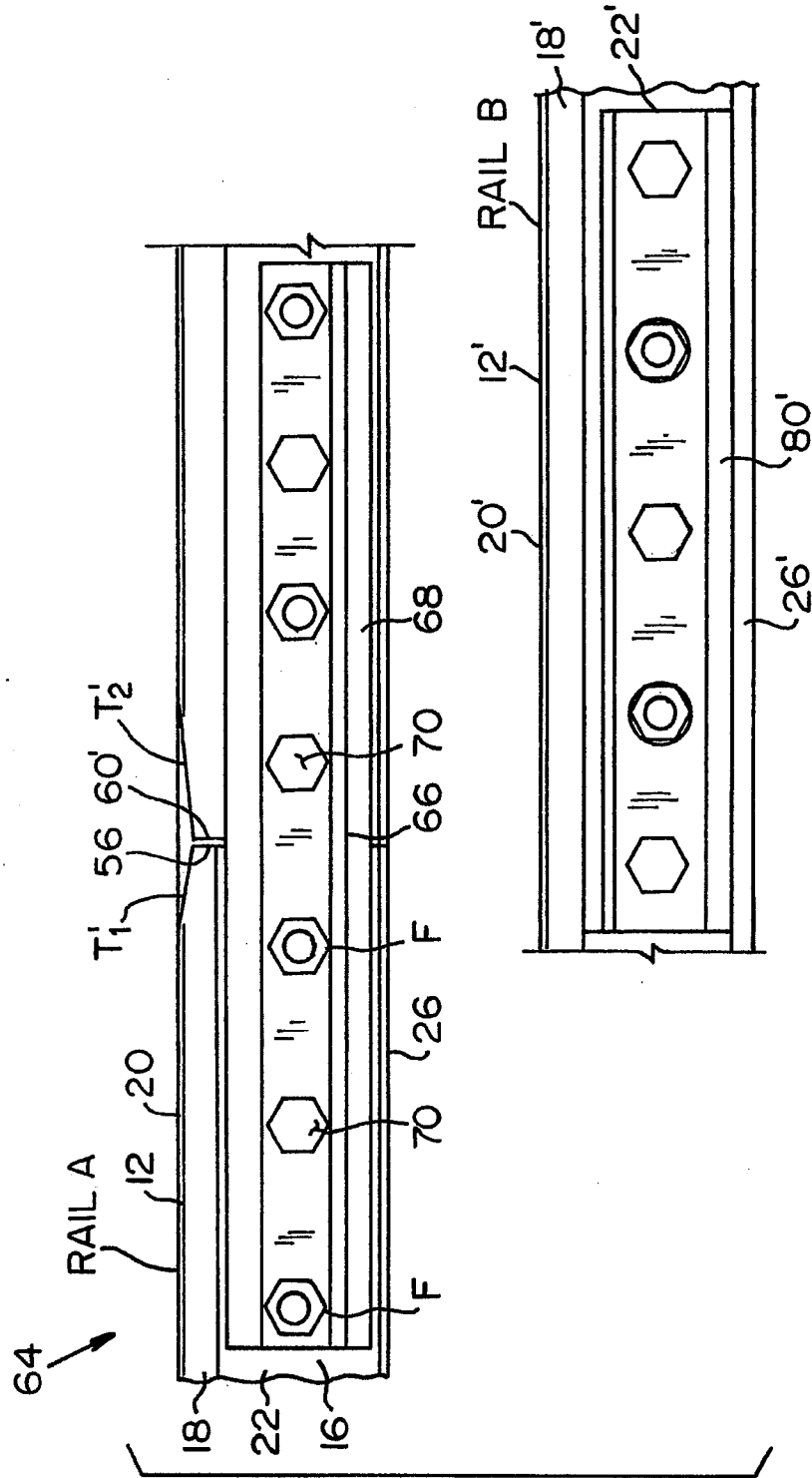

FIG. 10

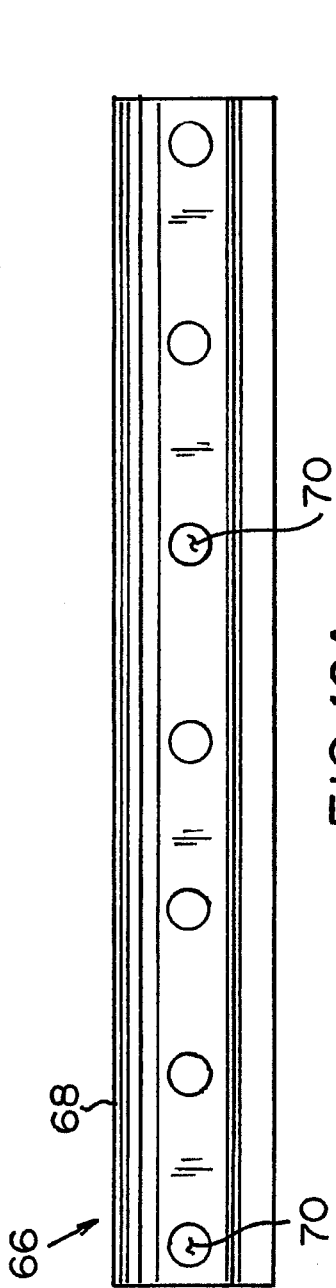

FIG. 12A

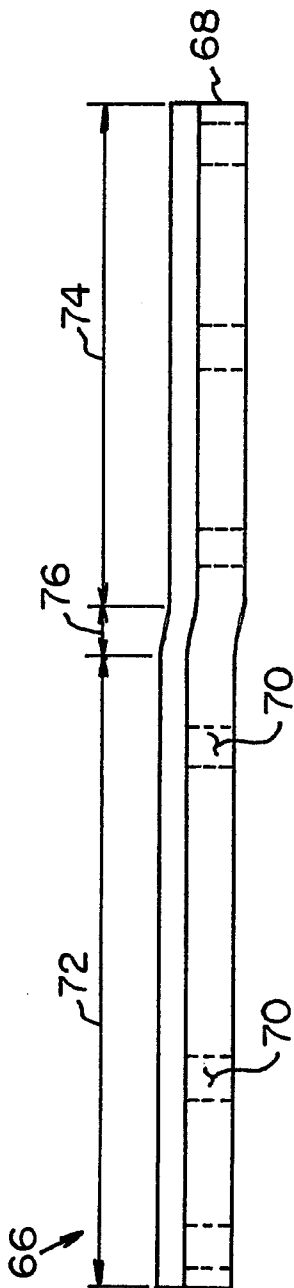

FIG. 12B

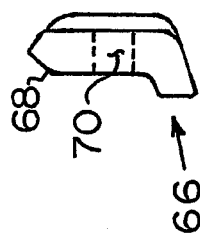

FIG. 12C

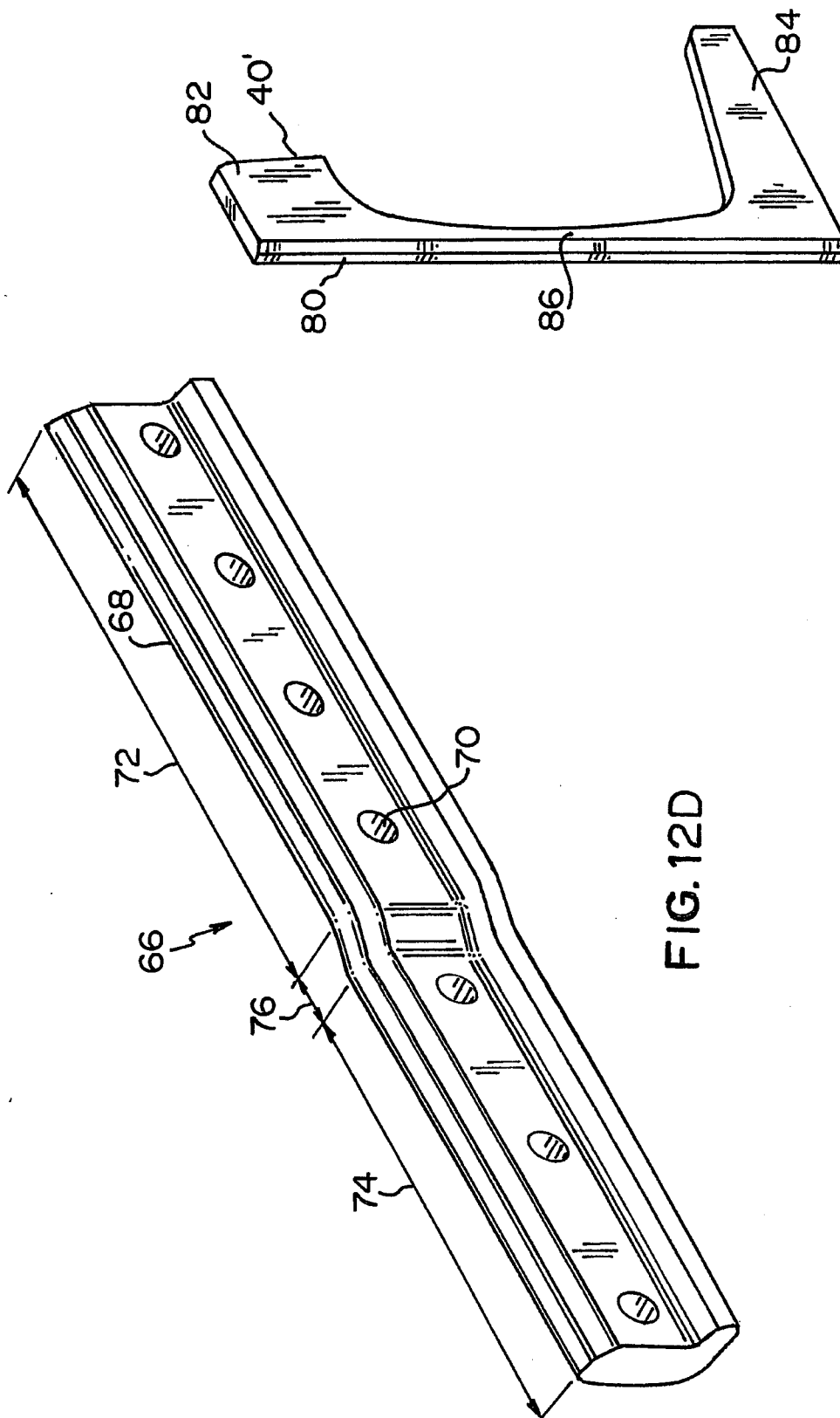

FIG. 13

FIG. 12D

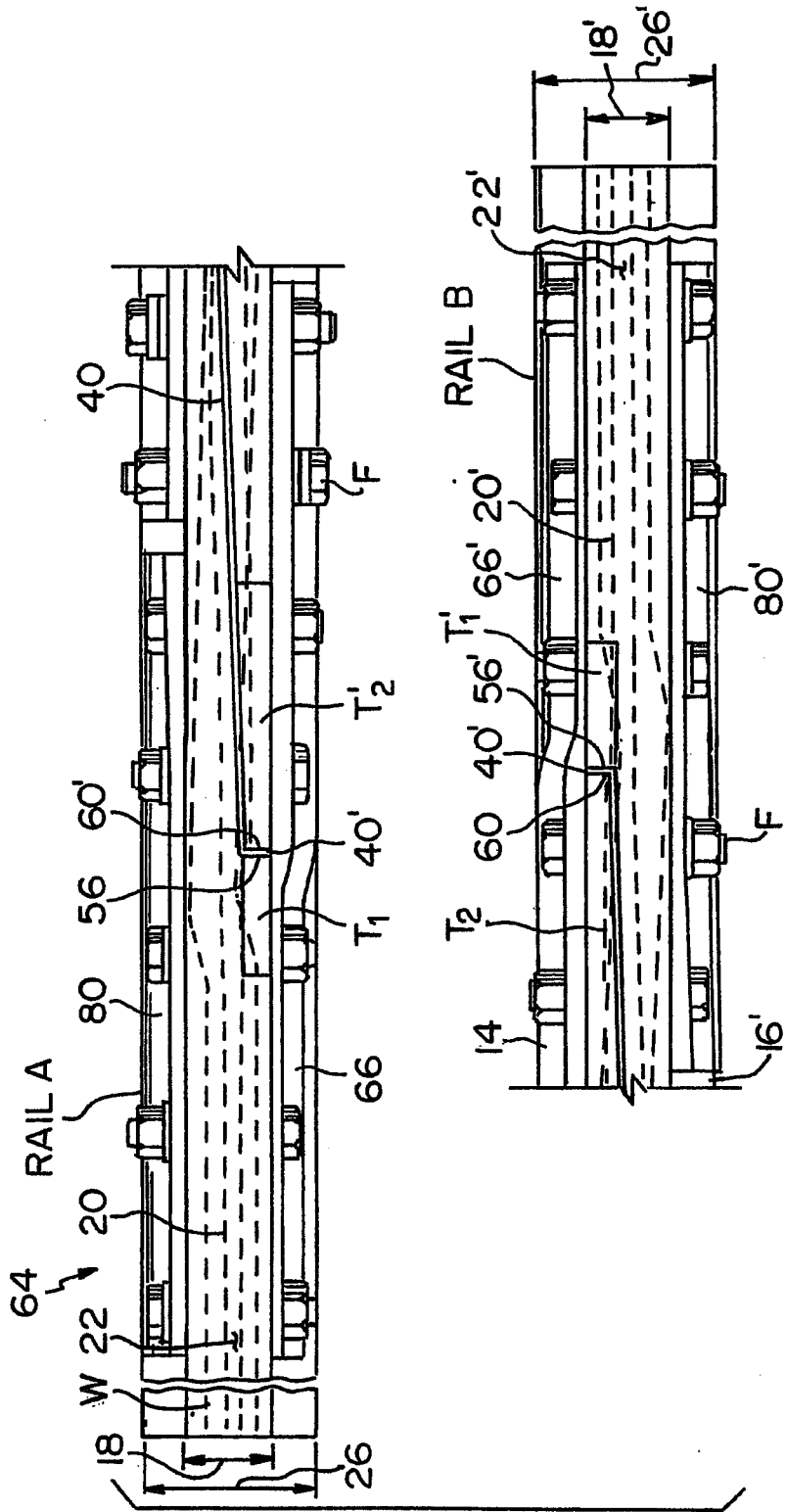

FIG. 14

