



(12) **DEMANDE DE BREVET CANADIEN**
CANADIAN PATENT APPLICATION

(13) **A1**

(22) Date de dépôt/Filing Date: 2020/02/27
(41) Mise à la disp. pub./Open to Public Insp.: 2020/09/01
(30) Priorité/Priority: 2019/03/01 (EP19397506.7)

(51) Cl.Int./Int.Cl. *A62C 31/28* (2006.01),
A62C 31/02 (2006.01), *H01Q 1/22* (2006.01),
H01Q 9/04 (2006.01), *H04B 1/59* (2006.01),
H04W 4/80 (2018.01)
(71) Demandeur/Applicant:
MARIOFF CORPORATION OY, FI
(72) Inventeur/Inventor:
KRUTSKEVYCH, NAZAR, FI
(74) Agent: NORTON ROSE FULBRIGHT CANADA
LLP/S.E.N.C.R.L., S.R.L.

(54) Titre : TETE D'EXTINCTEUR AVEC SONDE AYANT UN CIRCUIT FRID INTEGRE
(54) Title: SPRINKLER HEAD WITH A BULB HAVING AN EMBEDDED RFID CIRCUIT

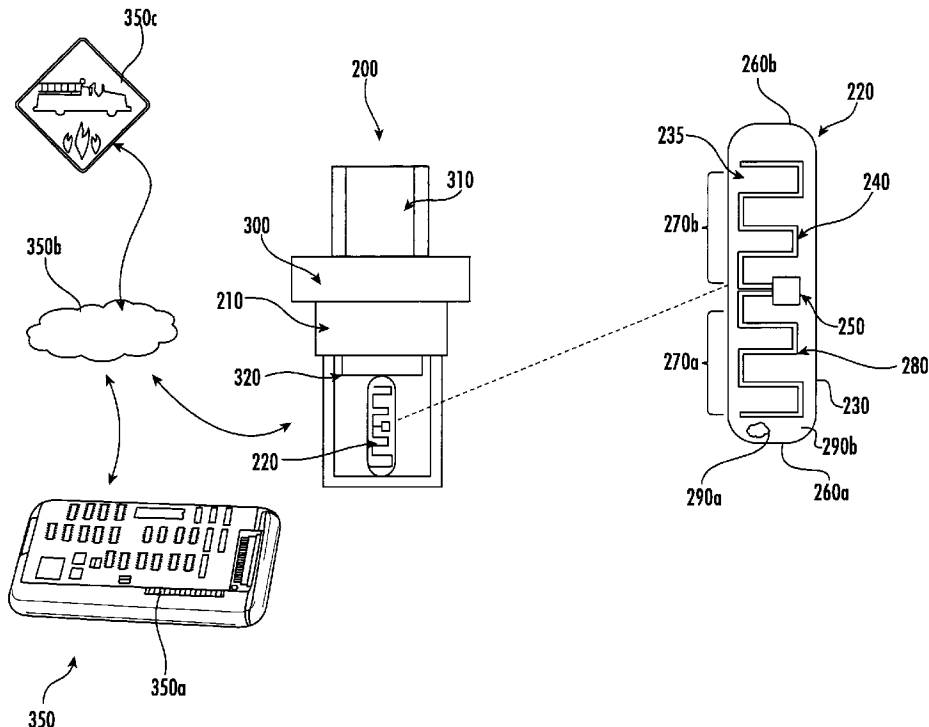

(57) **Abrégé/Abstract:**

Disclosed is a sprinkler head having: a sprinkler body; a frangible sprinkler bulb connected to the body, the frangible sprinkler bulb including: a cylindrical wall; and an RFID circuit embedded in the cylindrical wall.

ABSTRACT

Disclosed is a sprinkler head having: a sprinkler body; a frangible sprinkler bulb connected to the body, the frangible sprinkler bulb including: a cylindrical wall; and an RFID circuit embedded in the cylindrical wall.

SPRINKLER HEAD WITH A BULB HAVING AN EMBEDDED RFID CIRCUIT

BACKGROUND

[0001] The present disclosure relates to fire sprinkler heads and more specifically to a fire sprinkler head with a bulb having an embedded RFID circuit.

[0002] Fire sprinklers may be equipped with bulbs that are frangible and which fragment when exposed to heat induced from a fire. Fire sprinklers may be equipped with tags having radio frequency identification (RFID) circuits that include RFID antennas. A monitoring system may communicate with the tags to identify and locate the fire sprinkler. Such monitoring may assist with identifying a location of a fire condition. Connections between the tags and the fire sprinkler may result in the tag detaching and falling away upon fragmentation of the bulb in the presence of a fire condition. Detaching of the tags may compromise an ability of the monitoring system to track a location of a fire.

BRIEF SUMMARY

[0003] Disclosed is a sprinkler head comprising: a sprinkler body; a frangible sprinkler bulb connected to the body, the frangible sprinkler bulb including: a cylindrical wall; and an RFID circuit embedded in the cylindrical wall.

[0004] In addition to one or more of the above disclosed features or as an alternate the RFID circuit includes an antenna and a microchip operationally connected to the antenna; the antenna extending between opposing axial ends of the cylindrical wall; and the microchip disposed axially mid-span of the opposing axial ends of the cylindrical wall.

[0005] In addition to one or more of the above disclosed features or as an alternate the opposing axial ends of the cylindrical wall include a first end and a second end; the antenna includes a first portion and a second portion; the first portion extending between the microchip and the first end of the cylindrical wall; and the

second portion extending between the microchip and the second end of the cylindrical wall.

[0006] In addition to one or more of the above disclosed features or as an alternate the first portion of the antenna and the second portion of the antenna each comprise a periodic waveform pattern, each periodic waveform pattern propagating toward respective axial ends of the sprinkler bulb.

[0007] In addition to one or more of the above disclosed features or as an alternate each periodic waveform pattern is a square waveform.

[0008] In addition to one or more of the above disclosed features or as an alternate the cylindrical wall includes an inner surface and an outer surface, and the RFID circuit is embedded in one of the inner surface and the outer surface.

[0009] In addition to one or more of the above disclosed features or as an alternate the sprinkler head includes a mounting adaptor for connecting with a supply conduit.

[0010] In addition to one or more of the above disclosed features or as an alternate the sprinkler head includes a seal for fluidly isolating the bulb from the supply conduit.

[0011] Further disclosed is system comprising: the sprinkler head of In addition to one or more of the above disclosed features and a system controller, wherein the controller is configured for: communicating with the RFID circuit in the sprinkler head to obtain a status of the sprinkler head; and determining that a fire condition exists by identifying a communication break with the RFID circuit.

[0012] In addition to one or more of the above disclosed features or as an alternate the controller is configured for periodically communicating with the RFID circuit in the sprinkler head to obtain the status of the sprinkler head.

[0013] In addition to one or more of the above disclosed features or as an alternate the controller is configured for identifying a location of the RFID circuit, thereby identifying a location of the fire condition.

[0014] Disclosed is a method comprising of detecting a fire with a controller, comprising: communicating with an RFID circuit in a sprinkler head to obtain a status of the sprinkler head; and determining that a fire condition exists by identifying a communication break with the RFID circuit; wherein the sprinkler head comprises: a sprinkler body; a frangible sprinkler bulb connected to the body, the frangible sprinkler bulb including: a cylindrical wall; and the RFID circuit embedded in the cylindrical wall.

[0015] In addition to one or more of the above disclosed features or as an alternate the controller is configured for periodically communicating with the RFID circuit in the sprinkler head to obtain the status of the sprinkler head.

[0016] In addition to one or more of the above disclosed features or as an alternate the controller is configured for identifying a location of the RFID circuit, thereby identifying a location of the fire condition.

[0017] In addition to one or more of the above disclosed features or as an alternate the RFID circuit includes an antenna and a microchip operationally connected to the antenna; the antenna extending between opposing axial ends of the cylindrical wall; and the microchip disposed axially mid-span of the opposing axial ends of the cylindrical wall.

[0018] In addition to one or more of the above disclosed features or as an alternate the opposing axial ends of the cylindrical wall include a first end and a second end; the antenna includes a first portion and a second portion; the first portion extending between the microchip and the first end of the cylindrical wall; and the second portion extending between the microchip and the second end of the cylindrical wall.

[0019] In addition to one or more of the above disclosed features or as an alternate the first portion of the antenna and the second portion of the antenna each comprise a periodic waveform pattern, each periodic waveform pattern propagating toward respective axial ends of the sprinkler bulb.

[0020] In addition to one or more of the above disclosed features or as an alternate each periodic waveform pattern is a square waveform.

[0021] In addition to one or more of the above disclosed features or as an alternate the cylindrical wall includes an inner surface and an outer surface, and the RFID circuit is embedded in one of the inner surface and the outer surface.

[0022] In addition to one or more of the above disclosed features or as an alternate a mounting adaptor is provided for connecting with a supply conduit and a seal for fluidly isolating the bulb from the supply conduit.

BRIEF DESCRIPTION OF THE DRAWINGS

[0023] The present disclosure is illustrated by way of example and not limited in the accompanying figures in which like reference numerals indicate similar elements.

[0024] FIG. 1 illustrates a sprinkler head according to an embodiment;

[0025] FIG. 2 illustrates a frangible bulb according to an embodiment; and

[0026] FIG. 3 illustrates a process for monitoring for a fire condition according to an embodiment.

DETAILED DESCRIPTION

[0027] Turning to FIGS. 1 and 2, disclosed is a sprinkler head 200. The sprinkler head 200 may comprise a sprinkler body 210 and a frangible sprinkler bulb 220 that may be connected to the body 210. The frangible sprinkler bulb 220 may include a cylindrical wall 235 and an RFID (radio frequency identification) circuit 230. The RFID circuit 230 may be embedded in the cylindrical wall 235.

[0028] The RFID circuit 230 may include an antenna 240 and a microchip 250 operationally connected to the antenna 240. The antenna 240 may extend between opposing axial ends generally referred to as 260 of the cylindrical wall 235. The microchip 250 may be disposed axially mid-span of the opposing axial ends 260 of the cylindrical wall 235.

[0029] The opposing axial ends 260 of the cylindrical wall 235 may include a first end 260a and a second end 260b. The antenna 240 may include a plurality of axially extending portions generally referenced as 270 including first portion 270a and a second portion 270b. The first portion 270a may extend between the microchip 250 and the first end 260a of the cylindrical wall 235. The second portion 270b may extend between the microchip 250 and the second end 260 of the cylindrical wall 235.

[0030] The first portion 270a of the antenna 240 and the second portion 270b of the antenna 240 may each comprise a periodic waveform pattern generally referenced as 280. The periodic waveform pattern 280 may propagate toward respective axial ends 260 of the sprinkler bulb 220. The periodic waveform pattern 280 may be a square waveform.

[0031] The cylindrical wall 235 may include a plurality of surfaces generally referenced as 290, including an inner surface 290a (illustrated schematically) and an outer surface 290b. The RFID circuit 230 may be embedded in one of the plurality of surfaces 290 so as to render the RFID circuit 230 tamper-proof, for example, relative to an RFID tag.

[0032] A mounting adaptor 300 may be provided for connecting the sprinkler head 200 with a supply conduit 310. A seal 320 may be provided for fluidly isolating the bulb 220 from the supply conduit 310.

[0033] The sprinkler head 200 may be part of a fire detection system generally referenced as 350, which may include a system controller 350a that may be configured to electronically communicate with the RFID circuit 230 over a network 350b.

[0034] Turning to FIG. 3, the controller 350a may be configured for performing step S100 of monitoring for system alerts. Step S100 may include step S110 of communicating with the RFID circuit 230 in the sprinkler head 200 to obtain a status of the sprinkler head 200. At step S120 the controller may perform the step of determining that a fire condition exists by identifying a communication break with the RFID circuit 230.

[0035] In an embodiment, step S110 of communicating with the RFID circuit 230 may include step S130 of the controller 350a periodically communicating with the RFID circuit 230 in the sprinkler head 200 to obtain the status of the sprinkler head 200. For example, the controller may communicate every second with the RFID circuit so that a fire situation is not missed. At step S140 the controller 350a may identify a location of the RFID circuit 230 based on information stored in the RFID circuit 230, thereby identifying a location of the fire condition. The controller 350a may at step S150 provide one or more alerts for example to a fire station 350c over the same network 350b or a different network. The alerts may include identifying a fire at a location of the sprinkler head 200. At step S160 the process that began at step S100 may end with respect to the sprinkler head 200.

[0036] The above disclosed embodiments further provide a method for detecting a fire. The method may include a monitoring system detecting a break in the RFID antenna, which results from fragmentation of the bulb during a fire condition. The monitoring system may render a determination that a fire condition exists when it is unable to communicate with the RFID chip.

[0037] One benefit of the disclosed embodiments may include reducing manufacturing time and efforts for fire sprinklers that otherwise include frangible bulbs and RFID tags. Another benefit may include increasing a reliability of identifying a location of a fire. A reliability of a fire detection system may be unaffected by implementing the disclosed embodiments because modifications to the frangible bulb as provided herein are isolated from utilized water distribution implements. The bulbs disclosed herein may be tracked as soon as the bulbs are manufactured rather than having to be later equipped with a separate RFID tag.

Additionally, the antenna may be embedded within a bulb surface utilizing low cost manufacturing processes.

[0038] Disclosed embodiments identify one or more controllers and circuits that may utilize processor-implemented processes and devices for practicing those processes, such as a processor. Embodiments can also be in the form of computer program code containing instructions embodied in tangible media, such as network cloud storage, SD cards, flash drives, floppy diskettes, CD ROMs, hard drives, or any other computer-readable storage medium, wherein, when the computer program code is loaded into and executed by a computer, the computer becomes a device for practicing the embodiments. Embodiments can also be in the form of computer program code, for example, whether stored in a storage medium, loaded into and/or executed by a computer, or transmitted over some transmission medium, loaded into and/or executed by a computer, or transmitted over some transmission medium, such as over electrical wiring or cabling, through fiber optics, or via electromagnetic radiation, wherein, when the computer program code is loaded into an executed by a computer, the computer becomes an device for practicing the embodiments. When implemented on a general-purpose microprocessor, the computer program code segments configure the microprocessor to create specific logic circuits.

[0039] The term “about” is intended to include the degree of error associated with measurement of the particular quantity and/or manufacturing tolerances based upon the equipment available at the time of filing the application.

[0040] The terminology used herein is for the purpose of describing particular embodiments only and is not intended to be limiting of the present disclosure. As used herein, the singular forms “a”, “an” and “the” are intended to include the plural forms as well, unless the context clearly indicates otherwise. It will be further understood that the terms “comprises” and/or “comprising,” when used in this specification, specify the presence of stated features, integers, steps, operations, elements, and/or components, but do not preclude the presence or addition of one or more other features, integers, steps, operations, element components, and/or groups thereof.

[0041] Those of skill in the art will appreciate that various example embodiments are shown and described herein, each having certain features in the particular embodiments, but the present disclosure is not thus limited. Rather, the present disclosure can be modified to incorporate any number of variations, alterations, substitutions, combinations, sub-combinations, or equivalent arrangements not heretofore described, but which are commensurate with the scope of the present disclosure. Additionally, while various embodiments of the present disclosure have been described, it is to be understood that aspects of the present disclosure may include only some of the described embodiments. Accordingly, the present disclosure is not to be seen as limited by the foregoing description, but is only limited by the scope of the appended claims.

We claim:

1. A sprinkler head comprising:

a sprinkler body;

a frangible sprinkler bulb connected to the body, the frangible sprinkler bulb including:

a cylindrical wall; and

an RFID circuit embedded in the cylindrical wall.

2. The sprinkler head of claim 1, wherein:

the RFID circuit includes an antenna and a microchip operationally connected to the antenna;

the antenna extending between opposing axial ends of the cylindrical wall; and

the microchip disposed axially mid-span of the opposing axial ends of the cylindrical wall.

3. The sprinkler head of claim 2, wherein:

the opposing axial ends of the cylindrical wall include a first end and a second end;

the antenna includes a first portion and a second portion;

the first portion extending between the microchip and the first end of the cylindrical wall; and

the second portion extending between the microchip and the second end of the cylindrical wall.

4. The sprinkler head of claim 3, wherein:

the first portion of the antenna and the second portion of the antenna each comprise a periodic waveform pattern, each periodic waveform pattern propagating toward respective axial ends of the sprinkler bulb.

5. The sprinkler head of claim 4, wherein each periodic waveform pattern is a square waveform.

6. The sprinkler head of claim 5, wherein the cylindrical wall includes an inner surface and an outer surface, and the RFID circuit is embedded in one of the inner surface and the outer surface.

7. The sprinkler head of claim 6, comprising a mounting adaptor for connecting with a supply conduit.

8. The sprinkler head of claim 7, comprising a seal for fluidly isolating the bulb from the supply conduit.

9. A system comprising:

the sprinkler head of claim 8,

a system controller, wherein the controller is configured for:

communicating with the RFID circuit in the sprinkler head to obtain a status of the sprinkler head; and

determining that a fire condition exists by identifying a communication break with the RFID circuit.

10. The system of claim 9, wherein the controller is configured for periodically communicating with the RFID circuit in the sprinkler head to obtain the status of the sprinkler head.

11. The system of claim 10, wherein the controller is configured for identifying a location of the RFID circuit, thereby identifying a location of the fire condition.

12. A method comprising of detecting a fire with a controller, comprising:

communicating with an RFID circuit in a sprinkler head to obtain a status of the sprinkler head; and

determining that a fire condition exists by identifying a communication break with the RFID circuit; wherein

the sprinkler head comprises:

a sprinkler body;

a frangible sprinkler bulb connected to the body, the frangible sprinkler bulb including:

a cylindrical wall; and

the RFID circuit embedded in the cylindrical wall.

13. The method of claim 12, wherein the controller is configured for periodically communicating with the RFID circuit in the sprinkler head to obtain the status of the sprinkler head.

14. The method of claim 13, wherein the controller is configured for identifying a location of the RFID circuit, thereby identifying a location of the fire condition.

15. The method of claim 14, wherein:

the RFID circuit includes an antenna and a microchip operationally connected to the antenna;

the antenna extending between opposing axial ends of the cylindrical wall; and

the microchip disposed axially mid-span of the opposing axial ends of the cylindrical wall.

16. The method of claim 15, wherein:

the opposing axial ends of the cylindrical wall include a first end and a second end;

the antenna includes a first portion and a second portion;

the first portion extending between the microchip and the first end of the cylindrical wall; and

the second portion extending between the microchip and the second end of the cylindrical wall.

17. The method of claim 16, wherein:

the first portion of the antenna and the second portion of the antenna each comprise a periodic waveform pattern, each periodic waveform pattern propagating toward respective axial ends of the sprinkler bulb.

18. The method of claim 17, wherein each periodic waveform pattern is a square waveform.

19. The method of claim 18, wherein the cylindrical wall includes an inner surface and an outer surface, and the RFID circuit is embedded in one of the inner surface and the outer surface.

20. The method of claim 19, comprising a mounting adaptor for connecting with a supply conduit and a seal for fluidly isolating the bulb from the supply conduit.

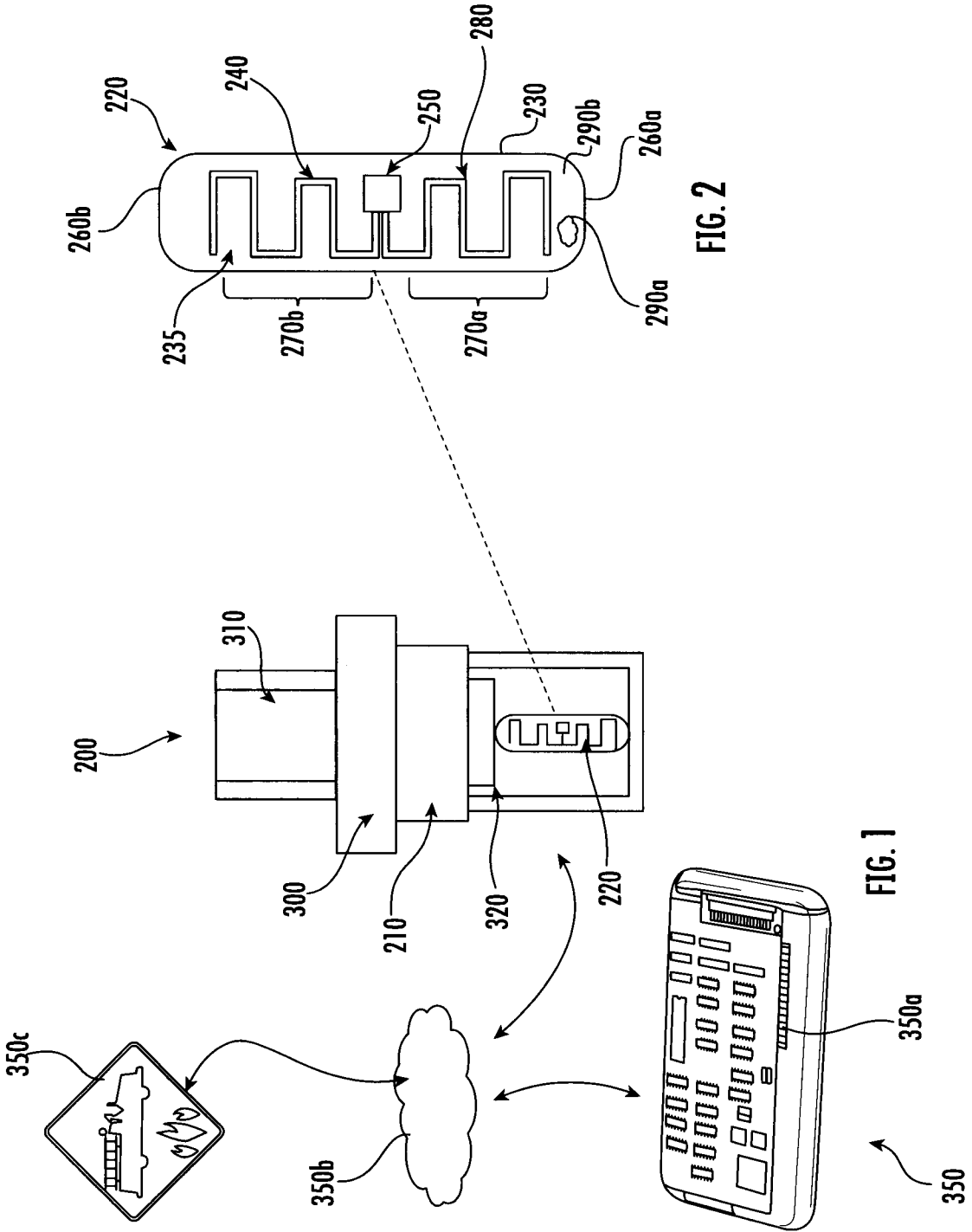

FIG. 2

FIG. 1

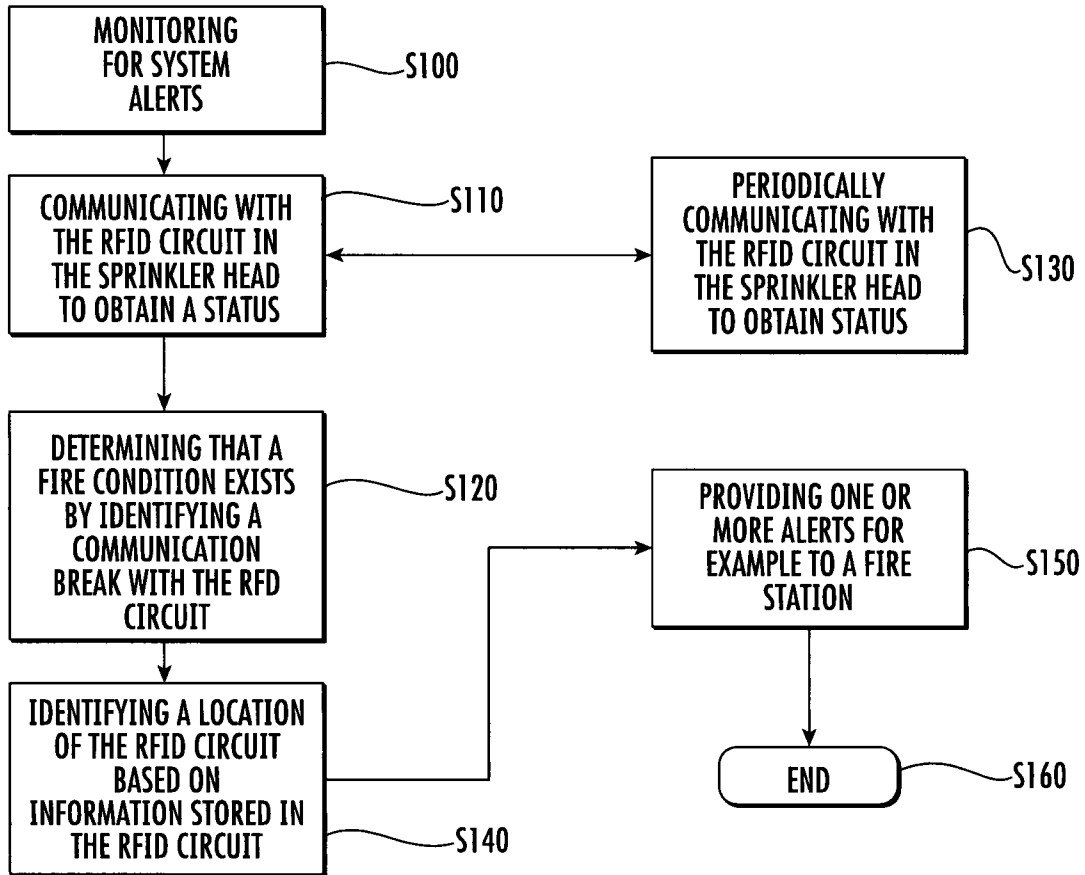

FIG. 3

