

(19) World Intellectual Property Organization
International Bureau



(43) International Publication Date
20 November 2008 (20.11.2008)

PCT

(10) International Publication Number
WO 2008/141238 A1

(51) International Patent Classification:

A61B 1/00 (2006.01) A61B 18/14 (2006.01)
A61B 1/008 (2006.01)

(21) International Application Number:

PCT/US2008/063324

(22) International Filing Date: 9 May 2008 (09.05.2008)

(25) Filing Language: English

(26) Publication Language: English

(30) Priority Data:

60/917,487 11 May 2007 (11.05.2007) US

(71) Applicant (for all designated States except US): **VOYAGE MEDICAL, INC.** [US/US]; 1357 Dell Avenue, Campbell, California 92008 (US).

(72) Inventors; and

(75) Inventors/Applicants (for US only): **WILLIS, N. Parker**

[US/US]; 98 Reservoir Road, Atherton, California 94027 (US). **MALCHANO, Zachary J.** [US/US]; 417 Missouri Street, San Francisco, California 94107 (US). **ROTHER, Chris A.** [US/US]; 1975 Playa Street, San Mateo, California 94403 (US). **SAADAT, Vahid** [US/US]; 12679 Kane Drive, Saratoga, California 95070 (US). **PEH, Ruey-Feng** [SG/US]; 707 Continental Circle #1811, Mountain View, California 94040 (US). **MILLER, David** [US/US]; 10050 Firwood Drive, Cupertino, California 95014 (US). **TAM, Edmund** [SG/US]; 707 Continental Circle, #1811, Mountain View, California 94040 (US).

(74) Agents: **HAN, Johny U.** et al.; Levine Bagade Han LLP, 2483 E. Bayshore Road, Suite 100, Palo Alto, California 94303 (US).

(81) Designated States (unless otherwise indicated, for every kind of national protection available): AE, AG, AL, AM, AO, AT, AU, AZ, BA, BB, BG, BH, BR, BW, BY, BZ, CA, CH, CN, CO, CR, CU, CZ, DE, DK, DM, DO, DZ, EC, EE, EG, ES, FI, GB, GD, GE, GH, GM, GT, HN, HR, HU, ID, IL, IN, IS, JP, KE, KG, KM, KN, KP, KR, KZ, LA, LC,

[Continued on next page]

(54) Title: VISUAL ELECTRODE ABLATION SYSTEMS

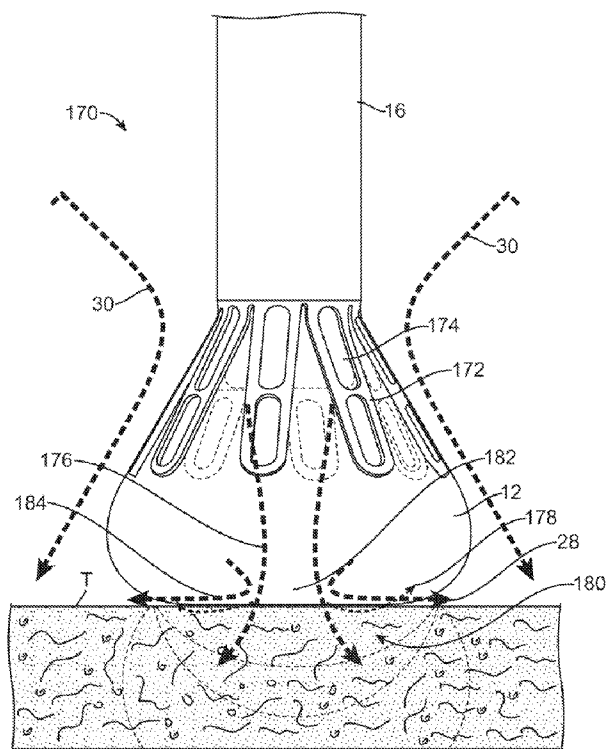

FIG. 11

(57) Abstract: Visual electrode ablation systems are described herein which include a deployment catheter and an attached imaging hood deployable into an expanded configuration. In use, the imaging hood is placed against or adjacent to a region of tissue to be imaged in a body lumen that is normally filled with an opaque bodily fluid such as blood. A translucent or transparent fluid, such as saline, can be pumped into the imaging hood until the fluid displaces any blood, thereby leaving a clear region of tissue to be imaged via an imaging element in the deployment catheter. An electric current may be passed through the fluid such that it passes directly to the tissue region being imaged and the electrical energy is conducted through the fluid without the need for a separate ablation probe or instrument to ablate the tissue being viewed.

WO 2008/141238 A1



LK, LR, LS, LT, LU, LY, MA, MD, ME, MG, MK, MN, MW, MX, MY, MZ, NA, NG, NI, NO, NZ, OM, PG, PH, PL, PT, RO, RS, RU, SC, SD, SE, SG, SK, SL, SM, SV, SY, TJ, TM, TN, TR, TT, TZ, UA, UG, US, UZ, VC, VN, ZA, ZM, ZW.

NO, PL, PT, RO, SE, SI, SK, TR), OAPI (BF, BJ, CF, CG, CI, CM, GA, GN, GQ, GW, ML, MR, NE, SN, TD, TG).

(84) Designated States (*unless otherwise indicated, for every kind of regional protection available*): ARIPO (BW, GH, GM, KE, LS, MW, MZ, NA, SD, SL, SZ, TZ, UG, ZM, ZW), Eurasian (AM, AZ, BY, KG, KZ, MD, RU, TJ, TM), European (AT, BE, BG, CH, CY, CZ, DE, DK, EE, ES, FI, FR, GB, GR, HR, HU, IE, IS, IT, LT, LU, LV, MC, MT, NL,

Declaration under Rule 4.17:

— *as to applicant's entitlement to apply for and be granted a patent (Rule 4.17(ii))*

Published:

— *with international search report*
— *before the expiration of the time limit for amending the claims and to be republished in the event of receipt of amendments*

VISUAL ELECTRODE ABLATION SYSTEMS

CROSS-REFERENCE TO RELATED APPLICATIONS

[0001] This application claims the benefit of priority to U.S. Prov. Pat. App. 60/917,487 filed May 11, 2007, which is incorporated herein by reference in its entirety.

FIELD OF THE INVENTION

[0002] The present invention relates generally to medical devices used for accessing, visualizing, and/or treating regions of tissue within a body. More particularly, the present invention relates to methods and apparatus for intravascularly accessing regions within the body, such as within the heart, and ablating tissue regions via energy delivery through an electrolytic fluid through which the tissue to be treated is also visualized.

BACKGROUND OF THE INVENTION

[0003] Conventional devices for accessing and visualizing interior regions of a body lumen are known. For example, ultrasound devices have been used to produce images from within a body *in vivo*. Ultrasound has been used both with and without contrast agents, which typically enhance ultrasound-derived images.

[0004] Other conventional methods have utilized catheters or probes having position sensors deployed within the body lumen, such as the interior of a cardiac chamber. These types of positional sensors are typically used to determine the movement of a cardiac tissue surface or the electrical activity within the cardiac tissue. When a sufficient number of points have been sampled by the sensors, a "map" of the cardiac tissue may be generated.

[0005] Another conventional device utilizes an inflatable balloon which is typically introduced intravascularly in a deflated state and then inflated against the tissue region to be examined. Imaging is typically accomplished by an optical fiber or other apparatus such as electronic chips for viewing the tissue through the membrane(s) of the inflated balloon. Moreover, the balloon must generally be inflated for imaging. Other conventional balloons utilize a cavity or depression formed at a distal end of the inflated balloon. This cavity or depression is pressed against the tissue to be examined and is

flushed with a clear fluid to provide a clear pathway through the blood.

[0006] However, such imaging balloons have many inherent disadvantages. For instance, such balloons generally require that the balloon be inflated to a relatively large size which may undesirably displace surrounding tissue and interfere with fine positioning of the imaging system against the tissue. Moreover, the working area created by such inflatable balloons are generally cramped and limited in size. Furthermore, inflated balloons may be susceptible to pressure changes in the surrounding fluid. For example, if the environment surrounding the inflated balloon undergoes pressure changes, e.g., during systolic and diastolic pressure cycles in a beating heart, the constant pressure change may affect the inflated balloon volume and its positioning to produce unsteady or undesirable conditions for optimal tissue imaging.

[0007] Accordingly, these types of imaging modalities are generally unable to provide desirable images useful for sufficient diagnosis and therapy of the endoluminal structure, due in part to factors such as dynamic forces generated by the natural movement of the heart. Moreover, anatomic structures within the body can occlude or obstruct the image acquisition process. Also, the presence and movement of opaque bodily fluids such as blood generally make *in vivo* imaging of tissue regions within the heart difficult.

[0008] Other external imaging modalities are also conventionally utilized. For example, computed tomography (CT) and magnetic resonance imaging (MRI) are typical modalities which are widely used to obtain images of body lumens such as the interior chambers of the heart. However, such imaging modalities fail to provide real-time imaging for intra-operative therapeutic procedures. Fluoroscopic imaging, for instance, is widely used to identify anatomic landmarks within the heart and other regions of the body. However, fluoroscopy fails to provide an accurate image of the tissue quality or surface and also fails to provide for instrumentation for performing tissue manipulation or other therapeutic procedures upon the visualized tissue regions. In addition, fluoroscopy provides a shadow of the intervening tissue onto a plate or sensor when it may be desirable to view the intraluminal surface of the tissue to diagnose pathologies or to perform some form of therapy on it.

[0009] Moreover, many of the conventional imaging systems lack the capability to provide therapeutic treatments or are difficult to manipulate in providing effective therapies. For instance, the treatment in a patient's heart for atrial fibrillation is generally made difficult by a number of factors, such as visualization of the target tissue, access to

the target tissue, and instrument articulation and management, amongst others.

[0010] Conventional catheter techniques and devices, for example such as those described in US Patent Number 5,895,417; 5,941,845; and 6,129,724, used on the epicardial surface of the heart may be difficult in assuring a transmural lesion or complete blockage of electrical signals. In addition, current devices may have difficulty dealing with varying thickness of tissue through which a transmural lesion is desired.

[0011] Conventional accompanying imaging devices, such as fluoroscopy, are unable to detect perpendicular electrode orientation, catheter movement during the cardiac cycle, and image catheter position throughout lesion formation. Without real-time visualization, it is difficult to reposition devices to another area that requires transmural lesion ablation. The absence of real-time visualization also poses the risk of incorrect placement and ablation of critical structures such as sinus node tissue which can lead to fatal consequences.

BRIEF SUMMARY OF THE INVENTION

[0012] A tissue imaging system which is able to provide real-time *in vivo* access to and images of tissue regions within body lumens such as the heart through opaque media such as blood and which also provides instruments for therapeutic procedures is provided by the invention.

[0013] The tissue-imaging apparatus relates to embodiments of a device and method to provide real-time images *in vivo* of tissue regions within a body lumen such as a heart, which is filled with blood flowing dynamically through it. Such an apparatus may be utilized for many procedures, e.g., mitral valvuloplasty, left atrial appendage closure, arrhythmia ablation (such as treatment for atrial fibrillation), transseptal access and patent foramen ovale closure among other procedures. Further details of such a visualization catheter and methods of use are shown and described in U.S. Pat. Pub. 2006/0184048 A1, which is incorporated herein by reference in its entirety.

[0014] Generally, the embodiments of a tissue imaging and manipulation device depicted in the present invention meet the challenge and solve the problem of accessing regions of the body which are typically difficult to access. The design and control of the catheter shaft and the distal tip of the device as disclosed here provide a device uniquely capable of accessing a region such as the human heart, which is a region not only difficult to access, but which also has continuous blood flow. The blood flow provides a barrier to

visualizing the local tissue, which in turn makes any manipulation at the local tissue nearly impossible. The unique elements that form the catheter shaft and the distal tip of the device, including the separate control of the shaft and tip and several optional modes of manipulation of either or both, provide for a device adaptable to addressing the challenges inherent in intravascular access and manipulation of heart tissue, and for accomplishing a procedure in any other difficult-to-access region in the body which is bathed in a medium that interferes with visualization.

[0015] Blood is continuously flowing through the heart at all times, and as such presents a challenge to direct visualization and subsequent manipulation of heart tissue. The tissue imaging and manipulation apparatus can comprise a delivery catheter or sheath through which a deployment catheter and imaging hood may be advanced for placement against or adjacent to the tissue to be imaged. The deployment catheter can have a fluid delivery lumen through it as well as an imaging lumen within which an optical imaging fiber or electronic imaging assembly may be disposed for imaging tissue. The distal tip of the device is an articulatable tip connected to the catheter shaft, when deployed, the imaging hood within the articulatable tip may be expanded into any number of shapes, e.g., cylindrical, conical as shown, semi-spherical, etc., provided that an open area or field is defined by the imaging hood. The open area of the articulatable tip is the area within which the tissue region of interest may be imaged. The imaging hood may also define an atraumatic contact lip or edge for placement or abutment against the tissue surface in the region of interest. The distal end of the deployment catheter or separate manipulatable catheters within a delivery sheath may be articulated through various controlling mechanisms such as push-pull wires manually or via computer control.

[0016] The visualization catheter may also have one or more membranes or layers of a polymeric material which covers at least a portion of the open area. The membrane or layer may be an extension of the deployed hood or it may be a separate structure. In either case, the membrane or layer may define at least one opening which allows for fluid communication between the visualization hood and the fluid environment within which the catheter is immersed.

[0017] In operation, after the imaging hood (at the articulatable tip) has been deployed, fluid may be pumped at a positive pressure through the fluid delivery lumen (within the catheter) until the fluid fills the open area completely and displaces any blood from within the open area. When the hood and membrane or layer is pressed against the tissue region to be visualized or treated, the contact between the one or more openings

and the tissue surface may help to retain the clear fluid within the hood for visualization. Moreover, the membrane or layer may help to retain the fluid within the hood while also minimizing any fluid leakage therefrom. Additionally, the one or more openings may also provide for direct access to the underlying tissue region to be treated by any number of tools or instruments positioned within the hood at the articulatable tip.

[0018] The fluid may comprise any biocompatible fluid, e.g., saline, water, plasma, Fluorinert™, etc., which is sufficiently transparent to allow for relatively undistorted visualization through the fluid. The fluid may be pumped continuously or intermittently to allow for image capture by an optional processor which may be in communication with the assembly.

[0019] The imaging hood may be deployed into an expanded shape and retracted within a catheter utilizing various mechanisms. Moreover, an imaging element, such as a CCD/CMOS imaging camera, may be positioned distally or proximally of the imaging hood when collapsed into its low-profile configuration. Such a configuration may reduce or eliminate friction during deployment and retraction as well as increase the available space within the catheter not only for the imaging unit but also for the hood.

[0020] In further controlling the flow of the purging fluid within the hood, various measures may be taken in configuring the assembly to allow for the infusion and controlled retention of the clearing fluid into the hood. By controlling the infusion and retention of the clearing fluid, the introduction of the clearing fluid into the patient body may be limited and the clarity of the imaging of the underlying tissue through the fluid within the hood may be maintained for relatively longer periods of time by inhibiting, delaying, or preventing the infusion of surrounding blood into the viewing field.

[0021] When ablating the underlying visualized tissue, a number of instruments may be utilized for performing the ablation upon the tissue, e.g., advancing an ablation probe through the hood and into ablative contact with the tissue while under direct visualization. Yet because an ablative probe is surrounded by the purging fluid, such as saline, which is already utilized for visualizing through to the underlying tissue, the conductive properties of the fluid may be taken advantage of by passing electrical currents directly through the fluid itself to the underlying tissue. Thus, tissue regions which are directly imaged through the fluid within the imaging hood may be ablated via electrical energy conducted through the fluid without the need for a separate ablation probe or instrument.

[0022] Ablation within the hood may further provide an isolated and controlled

environment for tissue ablation. With the blood purged from the hood interior, the visual electrode system may provide for more efficient ablation with less power and time involved and may further facilitate the formation of transmural lesions in the treated tissue. Additionally, the purging fluid may be varied in temperature, for example, to provide cooling to the underlying ablated tissue and the fluid may also be infused with any number of biological compounds for enhancing treatment of the tissue. Because the hood may also form a seal against regions with uneven anatomy, such as trabeculated tissue surfaces, the discharging electrode may ablate such tissue surfaces so long as the fluid discharged from hood is in contact with the underlying tissue rather than having to articulate a separate ablation probe for directly contacting the tissue regions between folds.

[0023] A visual electrode may thus be utilized for transmitting energy such as RF energy to the underlying tissue while simultaneously visualizing the same tissue being treated. This may be accomplished by use of a discharging electrode positioned through the deployment catheter to reside at least partially within the hood such that the electrode is in contact with the purging fluid. In other variations, one or more of the support struts along the hood itself may be optionally utilized as the discharging electrode. In either case, an unobstructed view of the ablation site directly beneath the electrode may be provided. This unobstructed view may not only provide visual confirmation of sufficient electrode-to-tissue contact, but may also provide visual confirmation of any changes in the color tissue. For example, visual confirmation of the blanching of the tissue color from a pink color to a whitened color may indicate confirmation of lesion formation and may be further indicative of sufficient electrode-to-tissue contact. Additionally, the blanched tissue may be indicative of a width and/or depth of the lesion formed in real time.

[0024] To access regions within the body, e.g., the chambers of the heart, the visual electrode assembly may be positioned upon an articulatable catheter having a dual-steering capability, such as a proximal section configured to articulate in a first plane, and a distal section configured to articulate in multiple planes, e.g., four-way steering capability. Alternatively, a passively steerable deployment catheter may be steered via an articulatable outer sheath which may be manually or computer controlled. Moreover, steering may further be enhanced by orientation markers placed upon the hood itself. Corresponding marks may be placed upon the handle as well to provide a directional indication of articulation direction when viewed upon a monitor of the visualization field

and in manipulating the hood accordingly.

[0025] Variations in the electrode structure may also be varied as well as variations in the hood structure itself to further facilitate visual ablation. For instance, the hood may be configured as an expandable membrane having one or more purging ports for ablation against angled tissue surfaces. Also, the discharging electrode may be formed as a sputter coated ring placed upon the distal membrane or other variations may be utilized.

[0026] Other variations may incorporate the use of suction or negative pressure formation within the hood to facilitate the formation of a seal between the aperture and underlying tissue. Such systems may be configured to form a recirculating flow within the hood to reduce saline discharge as well as to provide a cooling effect upon the treated tissue.

[0027] Because the ablative energy is transmitted through the purging fluid, lesions having a relatively wider area may be formed than possible with conventional ablation probes. The lesion area may be formed according to the size and/or shape of the aperture through which the purging fluid contacts the underlying tissue. Alternatively, a thin layer of saline fluid from the aperture may additionally become isolated beneath the base of the hood, thus further increasing the potential area for lesion formation. To facilitate measurement of the lesions under visualization, the hood and/or distal membrane may incorporate gradations or markings for estimating the size of lesions formed by the visual electrode.

[0028] Additionally, the visual confirmation of the ablated tissue may allow the user to also identify lesion borders during or post-treatment and may facilitate the formation of overlapping lesions to form contiguous lesions about tissue regions, such as the pulmonary vein ostia. Also, the hood may be utilized to locate previously formed discontinuous lesions for ablation of any gaps between these lesions.

[0029] Color feedback may also be utilized in determining whether irreversible tissue damage has been achieved as well as for determining temperature feedback during an ablation treatment. Such feedback may be provided not only by the tissue color itself, but also by features such as one or more thermochromic indicators positioned along the hood in contact with the treated tissue or within the hood for monitoring a temperature of the purging fluid.

[0030] Aside from visual confirmation of lesion formation, unobstructed visual confirmation of the tissue during ablation may allow for the monitoring of bubble

formation upon the tissue surface as indications of potential endocardial disruptions. Software incorporating algorithms using edge detection technology may be utilized to monitor the tissue surface for parameters such as the quantity and/or rate of bubble formation within the visual field. Such monitoring may be utilized to automatically to reduce or cease power levels to prevent any endocardial disruptions from occurring as a safety measure.

[0031] Other variations may incorporate the use of one or more electrode assemblies across the distal membrane of the hood to not only ensure contact with the tissue but for other features such as enabling electrocardiogram readings. Yet other features may include the use of ultrasound transducers for measuring tissue thicknesses for adjusting power levels accordingly. Such ultrasound transducers can also be used to determine the distance between the hood and the tissue to facilitate catheter manipulation and steering.

BRIEF DESCRIPTION OF THE DRAWINGS

[0032] Fig. 1A shows a side view of one variation of a tissue imaging apparatus during deployment from a sheath or delivery catheter.

[0033] Fig. 1B shows the deployed tissue imaging apparatus of Fig. 1A having an optionally expandable hood or sheath attached to an imaging and/or diagnostic catheter.

[0034] Fig. 1C shows an end view of a deployed imaging apparatus.

[0035] Figs. 1D to 1F show the apparatus of Figs. 1A to 1C with an additional lumen, e.g., for passage of a guidewire therethrough.

[0036] Figs. 2A and 2B show one example of a deployed tissue imager positioned against or adjacent to the tissue to be imaged and a flow of fluid, such as saline, displacing blood from within the expandable hood.

[0037] Fig. 3A shows an articulatable imaging assembly which may be manipulated via push-pull wires or by computer control.

[0038] Figs. 3B and 3C show steerable instruments, respectively, where an articulatable delivery catheter may be steered within the imaging hood or a distal portion of the deployment catheter itself may be steered.

[0039] Figs. 4A to 4C show side and cross-sectional end views, respectively, of another variation having an off-axis imaging capability.

[0040] Figs. 4D and 4E show examples of various visualization imagers which

may be utilized within or along the imaging hood.

[0041] Fig. 5 shows an illustrative view of an example of a tissue imager advanced intravascularly within a heart for imaging tissue regions within an atrial chamber.

[0042] Figs. 6A to 6C illustrate deployment catheters having one or more optional inflatable balloons or anchors for stabilizing the device during a procedure.

[0043] Figs. 7A and 7B illustrate a variation of an anchoring mechanism such as a helical tissue piercing device for temporarily stabilizing the imaging hood relative to a tissue surface.

[0044] Fig. 7C shows another variation for anchoring the imaging hood having one or more tubular support members integrated with the imaging hood; each support members may define a lumen therethrough for advancing a helical tissue anchor within.

[0045] Fig. 8A shows an illustrative example of one variation of how a tissue imager may be utilized with an imaging device.

[0046] Fig. 8B shows a further illustration of a hand-held variation of the fluid delivery and tissue manipulation system.

[0047] Figs. 9A to 9C illustrate an example of capturing several images of the tissue at multiple regions.

[0048] Figs. 10A and 10B show charts illustrating how fluid pressure within the imaging hood may be coordinated with the surrounding blood pressure; the fluid pressure in the imaging hood may be coordinated with the blood pressure or it may be regulated based upon pressure feedback from the blood.

[0049] Fig. 11 illustrates a side view of an example of an imaging hood configured to ablate contacted tissue under visualization via one or more electrodes transmitting energy through the electrolytic purging fluid and into and through the underlying tissue.

[0050] Fig. 12 shows a side view of another variation of the tissue visualization catheter ablating the underlying visualized tissue via a monopolar electrode assembly transmitting energy through the purging fluid.

[0051] Fig. 13 shows an assembly view of an example of an electrode assembly connectable to an ablation generator and positionable at least partially through the hood.

[0052] Fig. 14 illustrates an assembly view of one example of a visualization system configured for ablation through the purging fluid utilizing a monopolar electrode assembly.

[0053] Fig. 15 illustrates an assembly view of another example of a visualization system configured for visualized ablation while viewed upon a monitor.

[0054] Figs. 16A and 16B illustrate perspective and end views, respectively, of a visualization catheter positioned upon a tissue region for ablation treatment.

[0055] Fig. 16C illustrates a perspective view of the visualization catheter having completed ablation treatment and the resulting lesion upon the treated tissue.

[0056] Figs 16D and 16E illustrate perspective and end views, respectively, of another example where the hood may isolate the region of tissue beneath the distal membrane for ablation.

[0057] Fig. 16F illustrates a perspective view of the resulting lesion which is formed beneath the distal membrane approximating the diameter of the entire hood.

[0058] Fig. 17 shows a chart illustrating resultant lesion sizes formed during ablation treatment at various power levels and flow rates of the purging fluid.

[0059] Fig. 18A illustrates a perspective view of an example of a visualization catheter which defines a number of gradations over a distal membrane for estimating the size of ablated lesions and other anatomical features under direct visualization.

[0060] Figs. 18B and 18C illustrate other examples of gradations which may be placed upon the distal membrane to facilitate visual estimation of lesion size.

[0061] Fig. 19A shows another example of a distal membrane over the distal end of the hood defining a central aperture through which underlying tissue is visualized and ablated through the purging fluid.

[0062] Fig. 19B shows another example of multiple apertures defined over the membrane in the shape of uniformly spaced apertures which taper radially.

[0063] Fig. 19C shows another example of a central aperture surrounded circumferentially by multiple smaller apertures.

[0064] Fig. 19D shows yet another example of a central aperture surrounded circumferentially by a multiple smaller apertures.

[0065] Figs 20A and 20B show an end view of a hood having semicircular-shaped apertures and the resulting lesion formed upon the treated tissue, respectively.

[0066] Figs. 21A and 21B show an end view of another hood having a cross-shaped aperture and the resulting lesion formed upon the treated tissue, respectively.

[0067] Figs. 22A to 22C show perspective views of one variation of the visualization catheter with articulation capabilities.

[0068] Figs. 23A to 23D illustrate partial cross-sectional side views of a

visualization catheter articulating with a chamber of the heart for visualization and ablation treatment.

[0069] Fig. 24 shows a perspective view of a visualization catheter.

[0070] Figs. 25A and 25B show partial cross-sectional side views of the visualization catheter advanced through and articulated by a steerable sheath.

[0071] Figs. 26A and 26B show partial cross-sectional side views of the visualization catheter advanced through and articulated by a robotically controllable sheath.

[0072] Figs. 27A to 27C illustrate perspective views of an imaging hood having a number of directional indicators marked upon a distal membrane which correspond to directional indicators placed upon the handle for selective articulation regardless of hood orientation.

[0073] Figs. 28A and 28B show cross sectional side views of the left atrium having discontinuous lesions formed about the pulmonary vein ostium and the imaging hood inspecting and further ablating.

[0074] Fig. 29 illustrates an example of how the imaging hood may be positioned over trabeculated tissue for imaging and/or ablation treatment.

[0075] Fig. 30 shows a side view of another variation of imaging and treatment catheter with electrically conductive struts delivering energy to the underlying tissue.

[0076] Fig. 31 shows a side view of another variation of the imaging and treatment catheter with an energy delivery ring electrode proximal to the hood aperture.

[0077] Figs. 32A and 32B show side and perspective views, respectively, of another variation where a ring electrode is formed directly upon the distal membrane adjacent to the aperture.

[0078] Figs. 33A and 33B show side and perspective views, respectively, of yet another variation where concentric ring electrodes are formed directly upon the distal membrane to form a bipolar electrode configuration.

[0079] Figs. 34A and 34B show side views of another variation of an imaging hood having a tapered distal membrane which defines one or several additional apertures for selective tissue ablation therethrough.

[0080] Figs. 35A and 35B show side views of another variation of an imaging catheter configured as an expandable membrane having one or more apertures for selective tissue ablation therethrough.

[0081] Figs. 36A and 36B show side views of yet another variation of an imaging

catheter with an expandable membrane having a lumen defined therethrough and one or more apertures for selective tissue ablation.

[0082] Figs. 37A and 37B show side and end views, respectively, of an imaging catheter variation having a distal membrane defining a plurality of pores to facilitate purging fluid retention and circulation within the hood.

[0083] Figs. 38A to 38C illustrate side views of an imaging catheter placed against a tissue surface and having a negative pressure created within the hood to isolate and ensure contact against the tissue region to be visualized and treated.

[0084] Figs. 39A and 39B show side views of an imaging catheter positionable against a tissue surface and creating negative pressure within the hood to facilitate ablation via one or more electrically conductive struts along the hood.

[0085] Figs. 40A to 40C illustrate a view of the underlying tissue within the hood during an ablation procedure with bubble formation occurring upon the tissue surface.

[0086] Fig. 40D illustrates a perspective view of the resultant lesion formed by ablating through the hood.

[0087] Fig. 41 shows a flowchart outlining an example of an algorithm for utilizing the visual detection of bubble formation upon the ablated tissue surface for preventing tissue eruptions.

[0088] Fig. 42 shows another flowchart outlining an example of an algorithm for automatically reducing the ablation energy based upon bubble formation of the ablated tissue.

[0089] Fig. 43 shows a perspective view of a variation of the imaging hood with one or more electrocardiogram sensors disposed therealong for monitoring the ablated tissue.

[0090] Figs. 44A and 44B show partial cross-sectional side views of another variation utilizing electrodes positioned upon biased support members for detecting electrical activity of the underlying ablated tissue.

[0091] Fig. 44C shows a detail side view of an electrode assembly positioned upon one of the biased support members.

[0092] Fig. 45 shows a partial cross-sectional side view of another variation for detecting electrical activity of the underlying ablated tissue.

[0093] Fig. 46 shows a partial cross-sectional side view of another variation of the hood which incorporates one or more ultrasonic transducers for detecting a thickness of the underlying tissue for controlling the ablation energy.

[0094] Figs. 47A and 47B show side and perspective views of another variation of the hood which may incorporate one or more thermochromic indicators for visually monitoring a temperature of the ablated tissue and/or of the purging fluid.

[0095] Figs. 48A to 48D illustrate end views of the hood with the one or more thermochromic indicators changing its color to indicate a temperature of the ablated tissue.

[0096] Fig. 49 shows a flowchart of an example for adjusting the ablation energy based upon the indicated temperature change of the thermochromic indicator.

DETAILED DESCRIPTION OF THE INVENTION

[0097] Various exemplary embodiments of the invention are described below. Reference is made to these examples in a non-limiting sense. They are provided to illustrate more broadly applicable aspects of the present invention. Various changes may be made to the invention described and equivalents may be substituted without departing from the true spirit and scope of the invention. In addition, many modifications may be made to adapt a particular situation, material, composition of matter, process, process act(s) or step(s) to the objective(s), spirit or scope of the present invention. All such modifications are intended to be within the scope of the claims made herein.

[0098] The tissue-imaging and manipulation apparatus of the invention is able to provide real-time images *in vivo* of tissue regions within a body lumen such as a heart, which are filled with blood flowing dynamically through the region. The apparatus is also able to provide intravascular tools and instruments for performing various procedures upon the imaged tissue regions. Such an apparatus may be utilized for many procedures, e.g., facilitating transseptal access to the left atrium, cannulating the coronary sinus, diagnosis of valve regurgitation/stenosis, valvuloplasty, atrial appendage closure, arrhythmogenic focus ablation (such as for treating atrial fibrillation), among other procedures. Disclosure and information regarding tissue visualization catheters generally which can be applied to the invention are shown and described in further detail in commonly owned U.S. Pat. App. Serial No. 11/259,498 filed October 25, 2005, and published as 2006/0184048, which is incorporated herein by reference in its entirety. The basic apparatus for visualizing and manipulating tissue upon intravascular access to the target region are depicted in FIGs. 1-10. The specific details of the invention that permit specific access to difficult-to-access regions such as regions in the heart are depicted in

FIGs. 11 to 32. Specific embodiments depicting devices and methods for specific heart-based tissue manipulations such as forming lesions around the pulmonary ostia are shown in FIGs. 28 to 32.

[0099] One variation of a tissue access and imaging apparatus is shown in the detail perspective views of Figs. 1A to 1C. As shown in Fig. 1A, tissue imaging and manipulation assembly **10** may be delivered intravascularly through the patient's body in a low-profile configuration via a delivery catheter or sheath **14**. In the case of treating tissue, such as the mitral valve located at the outflow tract of the left atrium of the heart, it is generally desirable to enter or access the left atrium while minimizing trauma to the patient. To non-operatively effect such access, one conventional approach involves puncturing the intra-atrial septum from the right atrial chamber to the left atrial chamber in a procedure commonly called a transseptal procedure or septostomy. For procedures such as percutaneous valve repair and replacement, transseptal access to the left atrial chamber of the heart may allow for larger devices to be introduced into the venous system than can generally be introduced percutaneously into the arterial system.

[0100] When the imaging and manipulation assembly **10** is ready to be utilized for imaging tissue, imaging hood **12** may be advanced relative to catheter **14** and deployed from a distal opening of catheter **14**, as shown by the arrow. Upon deployment, imaging hood **12** may be unconstrained to expand or open into a deployed imaging configuration, as shown in Fig. 1B. Imaging hood **12** may be fabricated from a variety of pliable or conformable biocompatible material including but not limited to, e.g., polymeric, plastic, or woven materials. One example of a woven material is Kevlar® (E. I. du Pont de Nemours, Wilmington, DE), which is an aramid and which can be made into thin, e.g., less than 0.001 in., materials which maintain enough integrity for such applications described herein. Moreover, the imaging hood **12** may be fabricated from a translucent or opaque material and in a variety of different colors to optimize or attenuate any reflected lighting from surrounding fluids or structures, i.e., anatomical or mechanical structures or instruments. In either case, imaging hood **12** may be fabricated into a uniform structure or a scaffold-supported structure, in which case a scaffold made of a shape memory alloy, such as Nitinol, or a spring steel, or plastic, etc., may be fabricated and covered with the polymeric, plastic, or woven material. Hence, imaging hood **12** may comprise any of a wide variety of barriers or membrane structures, as may generally be used to localize displacement of blood or the like from a selected volume of a body lumen or heart chamber. In exemplary embodiments, a volume within an inner surface **13** of imaging

hood 12 will be significantly less than a volume of the hood 12 between inner surface 13 and outer surface 11.

[0101] Imaging hood 12 may be attached at interface 24 to a deployment catheter 16 which may be translated independently of deployment catheter or sheath 14.

Attachment of interface 24 may be accomplished through any number of conventional methods. Deployment catheter 16 may define a fluid delivery lumen 18 as well as an imaging lumen 20 within which an optical imaging fiber or assembly may be disposed for imaging tissue. When deployed, imaging hood 12 may expand into any number of shapes, e.g., cylindrical, conical as shown, semi-spherical, etc., provided that an open area or field 26 is defined by imaging hood 12. The open area 26 is the area within which the tissue region of interest may be imaged. Imaging hood 12 may also define an atraumatic contact lip or edge 22 for placement or abutment against the tissue region of interest.

Moreover, the diameter of imaging hood 12 at its maximum fully deployed diameter, e.g., at contact lip or edge 22, is typically greater relative to a diameter of the deployment catheter 16 (although a diameter of contact lip or edge 22 may be made to have a smaller or equal diameter of deployment catheter 16). For instance, the contact edge diameter may range anywhere from 1 to 5 times (or even greater, as practicable) a diameter of deployment catheter 16. Fig. 1C shows an end view of the imaging hood 12 in its deployed configuration. Also shown are the contact lip or edge 22 and fluid delivery lumen 18 and imaging lumen 20.

[0102] The imaging and manipulation assembly 10 may additionally define a guidewire lumen therethrough, e.g., a concentric or eccentric lumen, as shown in the side and end views, respectively, of Figs. 1D to 1F. The deployment catheter 16 may define guidewire lumen 19 for facilitating the passage of the system over or along a guidewire 17, which may be advanced intravascularly within a body lumen. The deployment catheter 16 may then be advanced over the guidewire 17, as generally known in the art.

[0103] In operation, after imaging hood 12 has been deployed, as in Fig. 1B, and desirably positioned against the tissue region to be imaged along contact edge 22, the displacing fluid may be pumped at positive pressure through fluid delivery lumen 18 until the fluid fills open area 26 completely and displaces any fluid 28 from within open area 26. The displacing fluid flow may be laminarized to improve its clearing effect and to help prevent blood from re-entering the imaging hood 12. Alternatively, fluid flow may be started before the deployment takes place. The displacing fluid, also described herein as imaging fluid, may comprise any biocompatible fluid, e.g., saline, water, plasma, etc.,

which is sufficiently transparent to allow for relatively undistorted visualization through the fluid. Alternatively or additionally, any number of therapeutic drugs may be suspended within the fluid or may comprise the fluid itself which is pumped into open area 26 and which is subsequently passed into and through the heart and the patient body.

[0104] As seen in the example of Figs. 2A and 2B, deployment catheter 16 may be manipulated to position deployed imaging hood 12 against or near the underlying tissue region of interest to be imaged, in this example a portion of annulus A of mitral valve MV within the left atrial chamber. As the surrounding blood 30 flows around imaging hood 12 and within open area 26 defined within imaging hood 12, as seen in Fig. 2A, the underlying annulus A is obstructed by the opaque blood 30 and is difficult to view through the imaging lumen 20. The translucent fluid 28, such as saline, may then be pumped through fluid delivery lumen 18, intermittently or continuously, until the blood 30 is at least partially, and preferably completely, displaced from within open area 26 by fluid 28, as shown in Fig. 2B.

[0105] Although contact edge 22 need not directly contact the underlying tissue, it is at least preferably brought into close proximity to the tissue such that the flow of clear fluid 28 from open area 26 may be maintained to inhibit significant backflow of blood 30 back into open area 26. Contact edge 22 may also be made of a soft elastomeric material such as certain soft grades of silicone or polyurethane, as typically known, to help contact edge 22 conform to an uneven or rough underlying anatomical tissue surface. Once the blood 30 has been displaced from imaging hood 12, an image may then be viewed of the underlying tissue through the clear fluid 30. This image may then be recorded or available for real-time viewing for performing a therapeutic procedure. The positive flow of fluid 28 may be maintained continuously to provide for clear viewing of the underlying tissue. Alternatively, the fluid 28 may be pumped temporarily or sporadically only until a clear view of the tissue is available to be imaged and recorded, at which point the fluid flow 28 may cease and blood 30 may be allowed to seep or flow back into imaging hood 12. This process may be repeated a number of times at the same tissue region or at multiple tissue regions.

[0106] In desirably positioning the assembly at various regions within the patient body, a number of articulation and manipulation controls may be utilized. For example, as shown in the articulatable imaging assembly 40 in Fig. 3A, one or more push-pull wires 42 may be routed through deployment catheter 16 for steering the distal end portion of the device in various directions 46 to desirably position the imaging hood 12 adjacent

to a region of tissue to be visualized. Depending upon the positioning and the number of push-pull wires **42** utilized, deployment catheter **16** and imaging hood **12** may be articulated into any number of configurations **44**. The push-pull wire or wires **42** may be articulated via their proximal ends from outside the patient body manually utilizing one or more controls. Alternatively, deployment catheter **16** may be articulated by computer control, as further described below.

[0107] Additionally or alternatively, an articulatable delivery catheter **48**, which may be articulated via one or more push-pull wires and having an imaging lumen and one or more working lumens, may be delivered through the deployment catheter **16** and into imaging hood **12**. With a distal portion of articulatable delivery catheter **48** within imaging hood **12**, the clear displacing fluid may be pumped through delivery catheter **48** or deployment catheter **16** to clear the field within imaging hood **12**. As shown in Fig. 3B, the articulatable delivery catheter **48** may be articulated within the imaging hood to obtain a better image of tissue adjacent to the imaging hood **12**. Moreover, articulatable delivery catheter **48** may be articulated to direct an instrument or tool passed through the catheter **48**, as described in detail below, to specific areas of tissue imaged through imaging hood **12** without having to reposition deployment catheter **16** and re-clear the imaging field within hood **12**.

[0108] Alternatively, rather than passing an articulatable delivery catheter **48** through the deployment catheter **16**, a distal portion of the deployment catheter **16** itself may comprise a distal end **49** which is articulatable within imaging hood **12**, as shown in Fig. 3C. Directed imaging, instrument delivery, etc., may be accomplished directly through one or more lumens within deployment catheter **16** to specific regions of the underlying tissue imaged within imaging hood **12**.

[0109] Visualization within the imaging hood **12** may be accomplished through an imaging lumen **20** defined through deployment catheter **16**, as described above. In such a configuration, visualization is available in a straight-line manner, i.e., images are generated from the field distally along a longitudinal axis defined by the deployment catheter **16**. Alternatively or additionally, an articulatable imaging assembly having a pivotable support member **50** may be connected to, mounted to, or otherwise passed through deployment catheter **16** to provide for visualization off-axis relative to the longitudinal axis defined by deployment catheter **16**, as shown in Fig. 4A. Support member **50** may have an imaging element **52**, e.g., a CCD or CMOS imager or optical fiber, attached at its distal end with its proximal end connected to deployment catheter **16**

via a pivoting connection 54.

[0110] If one or more optical fibers are utilized for imaging, the optical fibers 58 may be passed through deployment catheter 16, as shown in the cross-section of Fig. 4B, and routed through the support member 50. The use of optical fibers 58 may provide for increased diameter sizes of the one or several lumens 56 through deployment catheter 16 for the passage of diagnostic and/or therapeutic tools therethrough. Alternatively, electronic chips, such as a charge coupled device (CCD) or a CMOS imager, which are typically known, may be utilized in place of the optical fibers 58, in which case the electronic imager may be positioned in the distal portion of the deployment catheter 16 with electric wires being routed proximally through the deployment catheter 16. Alternatively, the electronic imagers may be wirelessly coupled to a receiver for the wireless transmission of images. Additional optical fibers or light emitting diodes (LEDs) can be used to provide lighting for the image or operative theater, as described below in further detail. Support member 50 may be pivoted via connection 54 such that the member 50 can be positioned in a low-profile configuration within channel or groove 60 defined in a distal portion of catheter 16, as shown in the cross-section of Fig. 4C. During intravascular delivery of deployment catheter 16 through the patient body, support member 50 can be positioned within channel or groove 60 with imaging hood 12 also in its low-profile configuration. During visualization, imaging hood 12 may be expanded into its deployed configuration and support member 50 may be deployed into its off-axis configuration for imaging the tissue adjacent to hood 12, as in Fig. 4A. Other configurations for support member 50 for off-axis visualization may be utilized, as desired.

[0111] Fig. 4D shows a partial cross-sectional view of an example where one or more optical fiber bundles 62 may be positioned within the catheter and within imaging hood 12 to provide direct in-line imaging of the open area within hood 12. Fig. 4E shows another example where an imaging element 64 (e.g., CCD or CMOS electronic imager) may be placed along an interior surface of imaging hood 12 to provide imaging of the open area such that the imaging element 64 is off-axis relative to a longitudinal axis of the hood 12. The off-axis position of element 64 may provide for direct visualization and uninhibited access by instruments from the catheter to the underlying tissue during treatment.

[0112] Fig. 5 shows an illustrative cross-sectional view of a heart H having tissue regions of interest being viewed via an imaging assembly 10. In this example, delivery

catheter assembly **70** may be introduced percutaneously into the patient's vasculature and advanced through the superior vena cava **SVC** and into the right atrium **RA**. The delivery catheter or sheath **72** may be articulated through the atrial septum **AS** and into the left atrium **LA** for viewing or treating the tissue, e.g., the annulus **A**, surrounding the mitral valve **MV**. As shown, deployment catheter **16** and imaging hood **12** may be advanced out of delivery catheter **72** and brought into contact or in proximity to the tissue region of interest. In other examples, delivery catheter assembly **70** may be advanced through the inferior vena cava **IVC**, if so desired. Moreover, other regions of the heart **H**, e.g., the right ventricle **RV** or left ventricle **LV**, may also be accessed and imaged or treated by imaging assembly **10**.

[0113] In accessing regions of the heart **H** or other parts of the body, the delivery catheter or sheath **14** may comprise a conventional intra-vascular catheter or an endoluminal delivery device. Alternatively, robotically-controlled delivery catheters may also be optionally utilized with the imaging assembly described herein, in which case a computer-controller **74** may be used to control the articulation and positioning of the delivery catheter **14**. An example of a robotically-controlled delivery catheter which may be utilized is described in further detail in US Pat. Pub. 2002/0087169 A1 to Brock et al. entitled "Flexible Instrument", which is incorporated herein by reference in its entirety. Other robotically-controlled delivery catheters manufactured by Hansen Medical, Inc. (Mountain View, CA) may also be utilized with the delivery catheter **14**.

[0114] To facilitate stabilization of the deployment catheter **16** during a procedure, one or more inflatable balloons or anchors **76** may be positioned along the length of catheter **16**, as shown in Fig. 6A. For example, when utilizing a transeptal approach across the atrial septum **AS** into the left atrium **LA**, the inflatable balloons **76** may be inflated from a low-profile into their expanded configuration to temporarily anchor or stabilize the catheter **16** position relative to the heart **H**. Fig. 6B shows a first balloon **78** inflated while Fig. 6C also shows a second balloon **80** inflated proximal to the first balloon **78**. In such a configuration, the septal wall **AS** may be wedged or sandwiched between the balloons **78**, **80** to temporarily stabilize the catheter **16** and imaging hood **12**. A single balloon **78** or both balloons **78**, **80** may be used. Other alternatives may utilize expandable mesh members, malecots, or any other temporary expandable structure. After a procedure has been accomplished, the balloon assembly **76** may be deflated or re-configured into a low-profile for removal of the deployment catheter **16**.

[0115] To further stabilize a position of the imaging hood **12** relative to a tissue surface to be imaged, various anchoring mechanisms may be optionally employed for temporarily holding the imaging hood **12** against the tissue. Such anchoring mechanisms may be particularly useful for imaging tissue which is subject to movement, e.g., when imaging tissue within the chambers of a beating heart. A tool delivery catheter **82** having at least one instrument lumen and an optional visualization lumen may be delivered through deployment catheter **16** and into an expanded imaging hood **12**. As the imaging hood **12** is brought into contact against a tissue surface **T** to be examined, anchoring mechanisms such as a helical tissue piercing device **84** may be passed through the tool delivery catheter **82**, as shown in Fig. 7A, and into imaging hood **12**.

[0116] The helical tissue engaging device **84** may be torqued from its proximal end outside the patient body to temporarily anchor itself into the underlying tissue surface **T**. Once embedded within the tissue **T**, the helical tissue engaging device **84** may be pulled proximally relative to deployment catheter **16** while the deployment catheter **16** and imaging hood **12** are pushed distally, as indicated by the arrows in Fig. 7B, to gently force the contact edge or lip **22** of imaging hood against the tissue **T**. The positioning of the tissue engaging device **84** may be locked temporarily relative to the deployment catheter **16** to ensure secure positioning of the imaging hood **12** during a diagnostic or therapeutic procedure within the imaging hood **12**. After a procedure, tissue engaging device **84** may be disengaged from the tissue by torquing its proximal end in the opposite direction to remove the anchor from the tissue **T** and the deployment catheter **16** may be repositioned to another region of tissue where the anchoring process may be repeated or removed from the patient body. The tissue engaging device **84** may also be constructed from other known tissue engaging devices such as vacuum-assisted engagement or grasper-assisted engagement tools, among others.

[0117] Although a helical anchor **84** is shown, this is intended to be illustrative and other types of temporary anchors may be utilized, e.g., hooked or barbed anchors, graspers, etc. Moreover, the tool delivery catheter **82** may be omitted entirely and the anchoring device may be delivered directly through a lumen defined through the deployment catheter **16**.

[0118] In another variation where the tool delivery catheter **82** may be omitted entirely to temporarily anchor imaging hood **12**, Fig. 7C shows an imaging hood **12** having one or more tubular support members **86**, e.g., four support members **86** as shown, integrated with the imaging hood **12**. The tubular support members **86** may define

lumens therethrough each having helical tissue engaging devices **88** positioned within. When an expanded imaging hood **12** is to be temporarily anchored to the tissue, the helical tissue engaging devices **88** may be urged distally to extend from imaging hood **12** and each may be torqued from its proximal end to engage the underlying tissue **T**. Each of the helical tissue engaging devices **88** may be advanced through the length of deployment catheter **16** or they may be positioned within tubular support members **86** during the delivery and deployment of imaging hood **12**. Once the procedure within imaging hood **12** is finished, each of the tissue engaging devices **88** may be disengaged from the tissue and the imaging hood **12** may be repositioned to another region of tissue or removed from the patient body.

[0119] An illustrative example is shown in Fig. 8A of a tissue imaging assembly connected to a fluid delivery system **90** and to an optional processor **98** and image recorder and/or viewer **100**. The fluid delivery system **90** may generally comprise a pump **92** and an optional valve **94** for controlling the flow rate of the fluid into the system. A fluid reservoir **96**, fluidly connected to pump **92**, may hold the fluid to be pumped through imaging hood **12**. An optional central processing unit or processor **98** may be in electrical communication with fluid delivery system **90** for controlling flow parameters such as the flow rate and/or velocity of the pumped fluid. The processor **98** may also be in electrical communication with an image recorder and/or viewer **100** for directly viewing the images of tissue received from within imaging hood **12**. Imager recorder and/or viewer **100** may also be used not only to record the image but also the location of the viewed tissue region, if so desired.

[0120] Optionally, processor **98** may also be utilized to coordinate the fluid flow and the image capture. For instance, processor **98** may be programmed to provide for fluid flow from reservoir **96** until the tissue area has been displaced of blood to obtain a clear image. Once the image has been determined to be sufficiently clear, either visually by a practitioner or by computer, an image of the tissue may be captured automatically by recorder **100** and pump **92** may be automatically stopped or slowed by processor **98** to cease the fluid flow into the patient. Other variations for fluid delivery and image capture are, of course, possible and the aforementioned configuration is intended only to be illustrative and not limiting.

[0121] Fig. 8B shows a further illustration of a hand-held variation of the fluid delivery and tissue manipulation system **110**. In this variation, system **110** may have a housing or handle assembly **112** which can be held or manipulated by the physician from

outside the patient body. The fluid reservoir **114**, shown in this variation as a syringe, can be fluidly coupled to the handle assembly **112** and actuated via a pumping mechanism **116**, e.g., lead screw. Fluid reservoir **114** may be a simple reservoir separated from the handle assembly **112** and fluidly coupled to handle assembly **112** via one or more tubes. The fluid flow rate and other mechanisms may be metered by the electronic controller **118**.

[0122] Deployment of imaging hood **12** may be actuated by a hood deployment switch **120** located on the handle assembly **112** while dispensation of the fluid from reservoir **114** may be actuated by a fluid deployment switch **122**, which can be electrically coupled to the controller **118**. Controller **118** may also be electrically coupled to a wired or wireless antenna **124** optionally integrated with the handle assembly **112**, as shown in the figure. The wireless antenna **124** can be used to wirelessly transmit images captured from the imaging hood **12** to a receiver, e.g., via Bluetooth® wireless technology (Bluetooth SIG, Inc., Bellevue, WA), RF, etc., for viewing on a monitor **128** or for recording for later viewing.

[0123] Articulation control of the deployment catheter **16**, or a delivery catheter or sheath **14** through which the deployment catheter **16** may be delivered, may be accomplished by computer control, as described above, in which case an additional controller may be utilized with handle assembly **112**. In the case of manual articulation, handle assembly **112** may incorporate one or more articulation controls **126** for manual manipulation of the position of deployment catheter **16**. Handle assembly **112** may also define one or more instrument ports **130** through which a number of intravascular tools may be passed for tissue manipulation and treatment within imaging hood **12**, as described further below. Furthermore, in certain procedures, fluid or debris may be sucked into imaging hood **12** for evacuation from the patient body by optionally fluidly coupling a suction pump **132** to handle assembly **112** or directly to deployment catheter **16**.

[0124] As described above, fluid may be pumped continuously into imaging hood **12** to provide for clear viewing of the underlying tissue. Alternatively, fluid may be pumped temporarily or sporadically only until a clear view of the tissue is available to be imaged and recorded, at which point the fluid flow may cease and the blood may be allowed to seep or flow back into imaging hood **12**. Figs. 9A to 9C illustrate an example of capturing several images of the tissue at multiple regions. Deployment catheter **16** may be desirably positioned and imaging hood **12** deployed and brought into position

against a region of tissue to be imaged, in this example the tissue surrounding a mitral valve **MV** within the left atrium of a patient's heart. The imaging hood **12** may be optionally anchored to the tissue, as described above, and then cleared by pumping the imaging fluid into the hood **12**. Once sufficiently clear, the tissue may be visualized and the image captured by control electronics **118**. The first captured image **140** may be stored and/or transmitted wirelessly **124** to a monitor **128** for viewing by the physician, as shown in Fig. 9A.

[0125] The deployment catheter **16** may be then repositioned to an adjacent portion of mitral valve **MV**, as shown in Fig. 9B, where the process may be repeated to capture a second image **142** for viewing and/or recording. The deployment catheter **16** may again be repositioned to another region of tissue, as shown in Fig. 9C, where a third image **144** may be captured for viewing and/or recording. This procedure may be repeated as many times as necessary for capturing a comprehensive image of the tissue surrounding mitral valve **MV**, or any other tissue region. When the deployment catheter **16** and imaging hood **12** is repositioned from tissue region to tissue region, the pump may be stopped during positioning and blood or surrounding fluid may be allowed to enter within imaging hood **12** until the tissue is to be imaged, where the imaging hood **12** may be cleared, as above.

[0126] As mentioned above, when the imaging hood **12** is cleared by pumping the imaging fluid within for clearing the blood or other bodily fluid, the fluid may be pumped continuously to maintain the imaging fluid within the hood **12** at a positive pressure or it may be pumped under computer control for slowing or stopping the fluid flow into the hood **12** upon detection of various parameters or until a clear image of the underlying tissue is obtained. The control electronics **118** may also be programmed to coordinate the fluid flow into the imaging hood **12** with various physical parameters to maintain a clear image within imaging hood **12**.

[0127] One example is shown in Fig. 10A which shows a chart **150** illustrating how fluid pressure within the imaging hood **12** may be coordinated with the surrounding blood pressure. Chart **150** shows the cyclical blood pressure **156** alternating between diastolic pressure **152** and systolic pressure **154** over time **T** due to the beating motion of the patient heart. The fluid pressure of the imaging fluid, indicated by plot **160**, within imaging hood **12** may be automatically timed to correspond to the blood pressure changes **160** such that an increased pressure is maintained within imaging hood **12** which is consistently above the blood pressure **156** by a slight increase ΔP , as illustrated by the

pressure difference at the peak systolic pressure **158**. This pressure difference, ΔP , may be maintained within imaging hood **12** over the pressure variance of the surrounding blood pressure to maintain a positive imaging fluid pressure within imaging hood **12** to maintain a clear view of the underlying tissue. One benefit of maintaining a constant ΔP is a constant flow and maintenance of a clear field.

[0128] Fig. 10B shows a chart **162** illustrating another variation for maintaining a clear view of the underlying tissue where one or more sensors within the imaging hood **12**, as described in further detail below, may be configured to sense pressure changes within the imaging hood **12** and to correspondingly increase the imaging fluid pressure within imaging hood **12**. This may result in a time delay, ΔT , as illustrated by the shifted fluid pressure **160** relative to the cycling blood pressure **156**, although the time delays ΔT may be negligible in maintaining the clear image of the underlying tissue. Predictive software algorithms can also be used to substantially eliminate this time delay by predicting when the next pressure wave peak will arrive and by increasing the pressure ahead of the pressure wave's arrival by an amount of time equal to the aforementioned time delay to essentially cancel the time delay out.

[0129] The variations in fluid pressure within imaging hood **12** may be accomplished in part due to the nature of imaging hood **12**. An inflatable balloon, which is conventionally utilized for imaging tissue, may be affected by the surrounding blood pressure changes. On the other hand, an imaging hood **12** retains a constant volume therewithin and is structurally unaffected by the surrounding blood pressure changes, thus allowing for pressure increases therewithin. The material that hood **12** is made from may also contribute to the manner in which the pressure is modulated within this hood **12**. A stiffer hood material, such as high durometer polyurethane or Nylon, may facilitate the maintaining of an open hood when deployed. On the other hand, a relatively lower durometer or softer material, such as a low durometer PVC or polyurethane, may collapse from the surrounding fluid pressure and may not adequately maintain a deployed or expanded hood.

[0130] In further controlling the flow of the purging fluid within the hood **12**, various measures may be taken in configuring the assembly to allow for the infusion and controlled retention of the clearing fluid into the hood. By controlling the infusion and retention of the clearing fluid, the introduction of the clearing fluid into the patient body may be limited and the clarity of the imaging of the underlying tissue through the fluid within the hood **12** may be maintained for relatively longer periods of time by inhibiting,

delaying, or preventing the infusion of surrounding blood into the viewing field.

[0131] In utilizing the hood **12** and various instruments through the hood for tissue treatment, hood **12** may be articulated in a variety of configurations to facilitate the access to regions within the heart. For instance, access to the left atrium of a patient's heart for performing treatments such as tissue ablation for atrial fibrillation may require hood **12** to be retroflexed in various configurations to enable sufficient access. Thus, the ability to control the steering or articulation of hood **12** within the patient's heart may facilitate tissue visualization and treatment.

[0132] Further examples of the visualization catheter assembly as well as methods of use are described in further detail in U.S. Pat. Pub. 2006/0184048 A1, which is incorporated herein by reference in its entirety.

[0133] When ablating the underlying visualized tissue, a number of instruments may be utilized for performing the ablation upon the tissue, e.g., advancing an ablation probe through the hood and into ablative contact with the tissue while under direct visualization. Yet because an ablative probe is surrounded by the purging fluid, such as saline, which is already utilized for visualizing through to the underlying tissue, the conductive properties of the fluid may be taken advantage of by passing electrical currents directly through the fluid itself to the underlying tissue. Thus, tissue regions which are directly imaged through the fluid within the imaging hood **12** may be ablated via electrical energy conducted through the fluid without the need for a separate ablation probe or instrument.

[0134] Fig. 11 illustrates a side view of an example of such a visual electrode assembly **170** which may visualize the underlying tissue **T** in a manner, as described above. With the hood **12** positioned upon the tissue surface and the clearing fluid **178**, such as saline, introduced into the hood interior to purge the bodily fluids **28** such as blood out of the hood **12**, the underlying tissue may be visualized directly. In this example, a separate RF electrode **174** may be positioned through deployment catheter **16** to reside at least partially within hood **12** such that electrode **174** is in electrical contact with the purging fluid **178**. Alternatively, electrode **174** need not reside within hood **12** at all but may be positioned more proximally of hood **12** within or along the catheter (or even reside within or along the handle) provided that electrode **174** is in electrical communication with the purging fluid **178** when the fluid **178** is introduced through hood **12**. In yet other alternatives, electrode **174** may be introduced as an instrument separate from the deployment catheter **16** and handle altogether. In other variations, one or more

of the support struts 172 may be optionally utilized as the discharging electrode, as described below in further detail.

[0135] As the purging fluid 178 passes through an aperture 182 defined over the distal membrane 184 which may cover the distal opening of hood 12, energy 176 may be discharged from electrode 174 such that it passes through the saline, which is electrolytic in nature, and is delivered directly to the visualized tissue visible through aperture 182 to ablate the underlying tissue 180. Further examples of such hood structures having apertures are shown and described in further detail in U.S. Pat. App. Serial No. 11/763,399 filed June 14, 2007, which is incorporated herein by reference in its entirety.

[0136] As the visualized tissue is ablated 180 within the visualization field (alternatively called a therapy field), hood 12 may advantageously isolate the ablation site from surrounding blood 30 and may also contain the discharged energy 176 within hood 12 such that the amount of electrical energy delivered to the tissue is optimized and is not lost to any blood flow. Moreover, the saline fluid passing into the body from hood 12 through aperture 182 may additionally form a thin layer of saline flowing across the tissue to hood interface to provide cooling of the surrounding tissue surfaces.

[0137] Fig. 12 illustrates a further variation of the visual electrode assembly where the discharging electrode 174 is positioned within hood 12 distally of deployment catheter 16 and within the saline filled environment of hood 12. Imaging element 52 is illustrated positioned along an inner surface of hood 12 for visualizing the underlying tissue below, as described above. In this variation, the visual electrode 174 assembly is configured as a monopolar electrode. Thus, grounding plate 186 may be placed in contact along an exterior skin surface of the patient's body to provide a return electrode for the ablation energy 180 flowing into the underlying tissue.

[0138] As mentioned, the discharging electrode may comprise a conventional ablation electrode. In other variations, it may be specifically configured for discharging RF energy through an electrolytic fluid environment. The example illustrated in Fig. 13 shows an assembly view of electrode assembly 190 which generally comprises an electrode shaft 192 extending from a proximal connector 198 and ending in a distal tip 194. Electrode shaft 192 may be fabricated from various electrically conductive materials such as copper, stainless steel, Nitinol, silver, gold, platinum, etc. which is covered with an insulative coating such as PET, latex, or other biocompatible polymers, etc. A conductive tip 196 may define a low profile segment fabricated from or plated with a similar conductive material and can adopt the shape of a sphere, dome, cylinder or other

desirable three-dimensional configuration configured to optimize the distal segment's surface area in contact with the distal tip **194** as well as the surrounding electrolytic fluid. The proximal connector **198** may be coupled to a cable **200** which is connectable, e.g., via a banana plug, etc., to an ablation energy generator **202**. In use, the conductive tip **196** may be positioned within the hood **12** distally of deployment catheter **16** and spaced away from the underlying tissue to be ablated such that direct contact between the tip **196** and tissue does not occur, although direct ablation via contact may also be accomplished if so desired.

[0139] As illustrated in the assembly view of Fig. 14, hood **12** and deployment catheter **16** may be coupled to handle **210**, through which the electrode may be coupled to the energy generator **202**. The example illustrated shows a monopolar ablation configuration and thus includes grounding plate **182** also electrically coupled to generator **202**. A separate actuation assembly **212**, e.g., foot pedal, may also be electrically coupled to generator **202** to allow for actuation of the ablation energy. Upon filling the hood **12** with saline and obtaining a clear view of the tissue region of interest, the RF ablation energy generator **202** can be activated via actuation assembly **212** to initiate the flow of electrical currents to be transmitted from the generator **202** and through the purging fluid, e.g., saline, via the electrode to electrically charge the saline within the imaging hood **12**. The saline within the hood **12** may function as a visual electrode to channel the RF energy into the tissue that is in contact with the saline, subsequently ablating said tissue with the RF energy. Hypersalinity saline with higher concentration of salts can also be used to improve the conductivity of the visual electrode system.

[0140] Accordingly, the tissue visualization and manipulation catheter with visual electrode described herein provides a platform to perform tissue ablation under direct real time *in vivo* visualization of the tissue before, during, and after an ablation process. Moreover, the purging fluid (such as saline) introduced into the imaging hood may possess the dual functions of clearing the field of view within the hood **12** and of providing a medium for ablating tissue in contact such that the visualized tissue may be ablated effectively and uniformly over a larger region of tissue than possible with a conventional ablation electrode which typically ablates through direct tissue contact with a probe.

[0141] As the assembly allows for ablation of tissue directly visualized through hood **12**, Fig. 15 illustrates an example of a system configured for enabling dual visualization and ablation. As shown in ablation assembly **220**, hood **12** and deployment

catheter 16 are coupled to handle 210, as previously described. Fluid reservoir 222, shown in this example as a saline-filled bag reservoir, may be attached through handle 210 to provide the clearing fluid and ablation medium. An optical imaging assembly 226 coupled to an imaging element positioned within or adjacent to hood 12 may extend proximally through handle 210 and be coupled to imaging processor assembly 224 for processing the images detected within hood 12. Assembly may also be coupled to a video receiving assembly 228 for receiving images from the optical imaging assembly 226. The video receiving assembly 228 may in turn be coupled to video processor assembly 230 which may process the detected images within hood 12 for display upon video display 232. Also shown are grounding plate 182 and ablation energy generator 202 which is coupled to ablation electrode within or proximate to hood 12, as previously described.

[0142] In use, as hood 12 is placed against the tissue region to be visualized and treated, as shown in the perspective view of Fig. 16A, visual confirmation of the desired tissue surface **T** or feature can be provided by the tissue visualization catheter via the imaging element. Upon visual confirmation, ablation generator 202 may be activated to ablate tissue exposed through a central aperture 240 having a diameter, e.g., 3 mm, defined in a distal membrane 242 extending over hood 12 as shown in the end view of Fig. 16B. The underlying tissue **T** may thus be ablated via the electrically charged purging fluid while still maintaining visual contact of the tissue **T**. As illustrated in the perspective view of Fig. 16C, a resulting lesion 180, such as a circularly-shaped lesion as illustrated, upon the tissue **T** approximating the size and shape of the aperture 240 can be accordingly formed because the flow reduction aperture 240 may effectively isolate the tissue region to be ablated to the area exposed to the fluid through aperture 240. Lesion size and shape can thus be modified by varying the size and the shape of the aperture at the distal face of the hood 12 where a relatively sufficient seal is formed between the aperture 240 and underlying tissue **T** to be treated.

[0143] In other treatment variations where a seal between the aperture and tissue surface is not formed tightly, as illustrated in the perspective and end views of Figs. 16D and 16E, the lesion formed upon the tissue may approximate the diameter and size of the entire hood 12 itself rather than the size of aperture 240. Fig. 16E shows an end view of hood 12 having an overall diameter **D** which is larger than aperture 240. When placed upon the tissue and the purging fluid is introduced into hood 12, the saline fluid may seep through aperture 240 while purging the blood from within hood 12 as well from any space formed between the distal membrane 242 and the tissue surface within the confines

of the hood diameter **D**. With the blood purged by the saline fluid, ablation energy may be actuated such that the energy flows through the fluid and into the space underlying aperture **240** and distal membrane **242**. The resulting lesion **180'** formed upon the tissue, as illustrated in Fig. 16F, may approximate the larger diameter **D** of hood **12** which is larger than the lesion formed through just aperture **240**. Distal membrane **242**, in this example, may thus act to isolate the tissue region directly beneath hood **12** for lesion formation.

[0144] The relative differences between the area of the aperture and the area of distal membrane may be varied depending upon the desired lesion size as well as the tissue region to be treated. In some variations, the area of the distal membrane (or hood diameter in contact against the tissue surface) may be at least twice as large as the cross sectional area of the deployment catheter or of the aperture.

[0145] Aside from aperture size and shape, other parameters which may be varied to adjust the ablative effects of the electrode may also include parameters such as the amount of power as well as the rate of purging fluid infusion (or irrigation flow) into hood **12**. Fig. 17 illustrates a chart illustrating the resulting lesion widths (measured in millimeters) at specified irrigation flow rates (measured in cc/min) versus the amount of applied power (measured in Watts) through the discharging electrode. To produce the results, an imaging hood **12** was coupled to an irrigation pump and an RF energy generator (Stockert 70 RF Generator). The irrigation flow rate through the hood **12** was initially set at 15 cc/min and the RF power was initially set at 25 W for a predetermined duration time of, e.g., 60 sec. As the purging saline fluid was introduced into hood **12**, ablation energy was actuated. If the underlying tissue did not generate any popping or produce any bubbles (which may be indicative of an impending endocardial eruption), the RF power was increased by 2 W and the ablation was repeated. If bubbles or popping did occur, the RF power was decreased by 2 W and the ablation was repeated. Generally, as illustrated in the chart, relatively higher irrigation flow rates (e.g., 25 cc/min) and relatively higher power levels (e.g., 50 W) produced relatively larger ablative lesions upon the underlying tissue.

[0146] Once an ablation procedure has begun or has been completed, the resulting lesion size may generally approximate the aperture opening. However, in determining the size of multiple lesions or a relatively large lesion, visually estimating the size may be difficult through hood **12**. Thus, one or more gradations **250** or markings may be placed upon the distal membrane **242** of hood **12** to allow for the visual measurement of

underlying lesions or other anatomical features which may be imaged through hood **12**. Fig. 18A shows a perspective view of one example of hood **12** having gradations **250** radially positioned upon membrane **242** much like a reticle. Other patterns or markings such as a grid patterned scale **252** or a concentric annular pattern **254**, as shown respectively in Figs. 18B and 18C, may be defined upon hood **12** or membrane **242**.

[0147] Returning to aperture size and shape in forming lesions upon the tissue surface, generally, the smaller the tissue surface area exposed through the aperture to the ablative fluid, the higher the relative ablation current density at the exposed tissue and the deeper the lesion formed into the tissue. The distance between the electrode and the underlying tissue may also contribute to the energy distribution through the tissue. As the electrode is closer to the tissue surface, the energy transfer is improved yet the farther away from the tissue surface, the more even the distribution of the energy transfer upon the tissue and the resulting lesion. However, placement of the electrode at too far a distance from the tissue may result in overheating of the saline fluid. Thus, a balance between electrode positioning and aperture size, shape, and/or placement may be utilized as parameters for tissue ablation. Fig. 19A illustrates an end view of hood **12** having a distal membrane **242** formed over the opening of hood **12** and defining a central aperture **260** having a diameter of, e.g., 3 mm, with a hood **12** having an outer diameter of, e.g., 8 mm. Fig. 19B illustrates another variation having multiple, e.g., four, uniformly spaced tapered tear-drop shaped apertures **262** each having a widened first end **264** and a tapered second end **266** extending radially from the center of hood **12**. Because the density of the discharged energy is higher at relatively smaller exposed areas, the discharged ablative energy may be uniformly maintained along the length of each aperture **262** as the higher energy density may offset the increased radial distance from the discharging electrode to result in a uniformly ablated lesion.

[0148] Another multiple aperture variation is shown in the end view of Fig. 19C, which illustrates a central aperture **268** having a diameter of, e.g., 2 mm, with a plurality of secondary apertures **270** (e.g., twelve apertures) each having a diameter of, e.g., 0.5 mm, spaced annularly at a first radius over membrane **242**. An additional plurality of tertiary apertures **272** (e.g., eight apertures) each also having a diameter of, e.g., 0.5 mm, and spaced annularly at a second radius over membrane **242** may also be defined over membrane **242**. Yet another variation is shown in the end view of Fig. 19D which illustrates a central aperture **274** having a diameter of, e.g., 2 mm, and a plurality of secondary apertures **276** each having a diameter of, e.g., 0.5 mm, spaced annularly at a

first radius.

[0149] Other configurations for the aperture may also take the form as shown in the end view of hood **12** in Fig. 20A, which illustrates two circumferentially spaced semicircular apertures **280**. When a tight seal is established between the aperture and tissue, the resulting lesions through the apertures are illustrated in the correspondingly ablated lesions **282** upon tissue **T** in Fig. 20B. Alternatively, as shown in the end view of Fig. 21, aperture may be formed as a crossed aperture **290** which may also form a correspondingly crossed lesion **292** upon tissue **T** in Fig. 21B when a sufficient seal is established between the aperture and tissue. These examples are intended to be illustrative and not limiting such that any variety of alternative aperture shapes and sizes may be utilized as so desired.

[0150] Intravascularly accessing the various tissue regions, e.g., within the various chambers of the heart, a deployment catheter having multiple steering capabilities may be utilized. An example is illustrated in Figs. 22A to 22C, which show perspective views of a hood **12** attached to a steerable segment of a deployment catheter **16**. The steerable segment may generally comprise a proximal steering section **300** configured to articulate within a single plane and a distal steering section **302** coupled distally of steering section **300** and configured to articulate in any number of directions, as shown. Further details of such an articulatable deployment catheter are shown in greater detail in U.S. Pat. App. Serial No. 12/108,812 filed April 24, 2008, which is incorporated herein by reference in its entirety. Alternatively, any number of other conventional steering catheters may also be utilized if so desired.

[0151] Deployment catheter may be advanced through an outer sheath **14**, e.g., through a femoral access route and into the right atrium **RA** of a patient's heart via the superior vena cava, as illustrated in Fig. 23A. Other intravascular access routes are of course possible and this particular access route is shown for illustrative purposes. In any case, once the deployment catheter having the articulatable segment has been introduced into the heart chamber, the steering sections **300**, **302** of catheter **16** may be articulated to position hood **12** against any region of tissue within the chamber for visualization and/or treatment, as illustrated in the partial cross-sectional views of Figs. 23B to 23D.

[0152] In another variation, a passively steerable hood **12** and deployment catheter **16**, as shown in the perspective view of Fig. 24, may be intravascularly introduced into the chambers of the heart, such as the left atrium **LA**, through a delivery catheter or sheath **310** which may itself be articulatable to control a position of hood **12**

within the heart chamber such as the left atrium **LA** for visualization and/or treatment, as shown in the partial cross-sectional side and detail side views of Figs. 25A and 25B, respectively. Another variation is illustrated in the partial cross-sectional side and detail side views of Figs. 26A and 26B, which illustrate a robotically controlled sheath **312** which may articulate an articulatable section **316** of the sheath via one or more control mechanisms **314** to control a position of hood **12** and deployment catheter **16**. Further details of such a system are shown and described in detail in U.S. Pat. App. Serial No. 11/848,429 filed August 31, 2007, which is incorporated herein by reference in its entirety.

[0153] Another example of a steering assembly which may be utilized with the ablative visual electrode assembly is illustrated in the perspective view of Fig. 27A which illustrates hood **12** and deployment catheter **16** coupled to handle **210**. Handle **210** may define one or more markings over the steering controls which correspond with identical or similar markings defined along the distal membrane of hood **12**. For example, Fig. 27B illustrates a perspective detail view of hood **12** illustrating a first directional indicator **320** at a first location along hood **12**, a second directional indicator **322** at a second location along hood **12**, a third directional indicator **324** at a third location along hood **12**, and a fourth directional indicator **326** along a fourth location along hood **12**. Each directional indicator may be distinct from one another and may correspond to the indicators located on handle **210**. As the user visualizes the tissue through hood **12**, if the hood **12** needed to be repositioned in any particular direction along the tissue, the user may note the direction to be moved relative to the indicators marked on hood **12** and may thus manipulate the controls on handle **210** accordingly such that movement of the controls in the chosen direction may articulate the hood **12** in the same direction, as illustrated in Fig. 27C. Such a feature may be highly advantageous relative to the absence of visual markings as it may be difficult for the user to steer the hood **12** in a desired direction after it is inserted into the patient's body due to the changes in hood orientation relative to the handle **210** orientation.

[0154] Once the hood **12** has been desirably positioned within the chamber, such as the left atrium **LA** as shown in the partial cross-sectional view of the heart **H** in Fig. 28A, hood **12** may be articulated utilizing any of the mechanisms and methods described herein to be placed against tissue such as the ostia of the pulmonary veins **PV** for visualization and/or treatment. A number of lesions **330** may thus be formed about the pulmonary vein **PV** ostium either continuously such that each lesion formed overlaps an

adjacent lesion to aggregately form a continuously-adjoined lesion or a number of discontinuous lesions may be formed adjacent to one another. Hood **12** may be articulated to visually inspect lesions which may have been formed previously in prior treatments for locating discontinuities or gaps between adjacent lesions. Once identified, the visual electrode may be activated to close any gaps by ablating the underlying tissue visualized to form a contiguous lesion upon the tissue, as shown in the partial cross-sectional view of Fig. 28B. This process can be repeated until a contiguous lesion is formed on the desired pulmonary vein ostium, e.g., so as to isolate electrical signals from propagating from the pulmonary vein **PV** to the left atrium **LA**. Such methods may be used to treat conditions for cardiac arrhythmia such as atrial fibrillation, ventricular tachycardia, etc.

[0155] In positioning hood **12** against the tissue surface to be visualized and/or ablated, the surface anatomy may present an uneven surface which may generally inhibit the formation of a sufficient seal between the hood aperture and tissue. An example may include trabeculated tissue surfaces **340** which define a number of tissue folds **342**. As illustrated in the partial cross-sectional side view of Fig. 29, hood **12** may still form a sufficient seal against the tissue surface by repositioning the hood **12** over the trabeculated tissue surface **340** at a location where the purging fluid **344** introduced into hood **12** is able to temporarily fill the underlying folds **342** such that the fluid is retained **346** within the folds. In this manner, visualization may be accomplished and ablation energy may be transmitted through the fluid **344** and into the underlying trabeculated tissue.

[0156] Rather than utilizing a separate ablation electrode positioned through deployment catheter **16** and within hood **12**, one or more of the support struts which may be embedded in the architecture of hood **12** may be utilized as a discharging ablation electrode. An example is illustrated in the side view of Fig. 30, which shows hood **12** having a number of support struts **350** extending distally along or within membrane of hood **12**. One or more of the support struts **350** may be fabricated from electrically conductive materials or coated with electrically conductive materials such as copper, stainless steel, Nitinol, silver, gold, platinum, etc. An insulated electrical wire through deployment catheter **16** may be electrically connected to the one or more electrically conductive support struts **350** along the hood **12**. In some variations, the conductive support struts **350** may be exposed internally within the hood **12** while exteriorly of hood **12**, the support struts **350** may be covered by the membrane (or wall) of hood **12** such that

they are not in contact with fluids, tissue, or bodies outside the hood **12**. Additionally, because this particular configuration does not require the use of a separate ablative electrode, the availability of space through the deployment catheter **16** is increased allowing for the insertion of additional instruments. Functionally, with the ablative energy activated, the electrical current may be discharged along the one or more conductive support struts **350** and through the purging fluid and into the underlying tissue exposed through aperture **182**.

[0157] Another variation is shown in the side view of Fig. 31, which illustrates hood **12** having an energizable ring electrode **352** extending from a ring electrode support **354** and positioned within hood **12** in proximity to aperture **182**. The energy delivery portion of ring electrode **352** may be confined to the ringed portion by insulation along support **354**. Moreover, as support **354** is moved proximally or distally within hood **12** relative to aperture **182**, the distance between ring electrode **352** and aperture **182** may be controlled to alter the ablative characteristics upon the underlying tissue through the aperture **182**. Additionally, having the circular configuration around the aperture **182** of the hood **12** may also increase the efficiency of the ablation process as ablation energy is efficiently delivered to the ablation area.

[0158] Yet another variation is illustrated in the partial cross-sectional side and perspective views of Figs. 32A and 32B, respectively, which show an energizable ring electrode **360** coated or placed directly upon the membrane of hood **12**. Ring electrode **360** may be placed directly upon the membrane utilizing various techniques (e.g., sputter coating, chemical vapor deposition, etc.) where a layer of conductive material is sprayed or laid upon a mask and the underlying hood material to create the ringed structure. Electrode **360** may be connected electrically via a wire which passes along an interior surface of hood **12** and through deployment catheter **16**. This particular variation illustrates ring electrode **360** formed upon an inner surface of membrane **184** within hood **12** adjacent to aperture **182**. In other variations, ring electrode **360** may be formed along other locations within hood **12** along membrane **184** or further proximally along an inner surface of hood **12**.

[0159] In any event, once the purging fluid is introduced into hood **12** and the underlying tissue **T** is visualized, ring electrode **360** may be energized resulting in a uniform dispersion of the energy **362** through the visualization fluid within hood **12** and into the underlying tissue **T** for ablative treatment. Additionally, ring electrode **360** may further provide structural rigidity to hood **12** and inhibit the hood membrane from folding

undesirably. The sputter coated ring electrode **360** may have a thickness ranging anywhere from 0.1 to 5 micrometers and the width of the electrode **360** may be varied as so desired depending upon the ablative effects and energy discharge.

[0160] Figs. 33A and 33B show partial cross-sectional side and perspective views, respectively, of yet another variation where the ring electrode **360** may be configured as a bipolar electrode assembly. As illustrated, with ring electrode **360** placed upon an inner surface of membrane **184** adjacent to aperture **182**, a return electrode **364** may be similarly situated upon an exterior surface of membrane **184** such that the purging fluid introduced within hood **12** may be charged by ring electrode **360** and directed out of aperture **182** and towards return electrode **364** located on an external surface of membrane **184** in contact against the underlying tissue **T** such that the energy **362** may effectively ablate the tissue.

[0161] Aside from variations in the electrode structure or configuration, the hood and distal membrane may also be configured in alternative ways to change the ablative characteristics of the assembly. For instance, Figs. 34A and 34B show side views of a variation of a visual electrode assembly where hood **12** may have an extendable membrane **370** disposed over hood **12** such that a distally extending conical or diamond shape configuration is formed when hood **12** is filled with saline fluid. The variation illustrated has multiple purging ports **372** defined circumferentially over extendable membrane **370** proximally of aperture **182** and may function as side irrigation channels for the saline fluid to purge blood out of hood **12** during visualization. Because the distally extending membrane **370** forms a tapered surface, this particular variation may be suited for contacting tissue surfaces at an angle, such as the ostium surrounding an opening of a pulmonary vein **PV**, as illustrated in Fig. 34B. The purging ports **372** may thus directly contact the underlying ostium and ablate the tissue directly through purging ports **372**.

[0162] Direct visualization and inspection of the pulmonary vein ostium can be performed through hood **12** and ablation under direct visualization can be subsequently performed on the ostium through the ports **372** upon the exposed tissue of the ostium. Contiguous lesions can be formed by repeating the process and rotating the hood **12** along the longitudinal axis to reposition the visual electrode side ports **372** to surfaces that are un-ablated. An optional anchoring member **374**, such as a helical anchor, may be deployed from deployment catheter **16**, through aperture **182**, and into the pulmonary vein **PV** where it may be deployed for temporarily securing itself against the vessel walls

during visualization and/or ablation. Other tools such as guidewires, needles, dilators, graspers, ablation probes, other pulmonary vein anchors, etc. may also be utilized.

[0163] In the case where tools need not be used, the central aperture **182** may be enclosed entirely and in the event when tools are needed to pass through the enclosed distal face of the hood **12**, a needle can be used to puncture through the hood membrane and other tools may be advanced through the opening to access to the exterior area of the hood **12**.

[0164] Although multiple purging ports **372** are illustrated, a single side opening may be used instead. In such a variation of the device, the visualization catheter may be rotated by the user to form continuous lesions around the ostium of the pulmonary vein **PV**. The user may be able to visualize the tissue undergoing ablation and rotate the hood **12** to ablate an adjacent tissue region accordingly.

[0165] Another variation of an alternative hood structure is illustrated in the perspective and side views, respectively, of Figs. 35A and 35B which show a visual electrode assembly which utilizes an expandable membrane **380** which is enclosed except for one or more side purging ports **382** through which the purging fluid **388** may escape. An electrode **386** may be positioned along a support member **384** which extends through membrane **380** and distally thereof. The electrode **386** may form a helical coil along the support member **384** and can terminate at the distal inner area of the membrane **380** to deliver ablation energy to areas in close proximity to the purging ports **382**. Similar to the variation described above, because the surface of membrane **380** is tapered, the assembly may be particularly suited for positioning against the ostium of a pulmonary vein **PV** so that ablation energy discharged from electrode **386** within membrane **380** may be directed through the purging fluid **388** escaping through the one or more purging ports **382** and into the tissue surrounding the ostium, as shown in Fig. 35B. A distal balloon anchor **390** may be positioned along a distal tip or portion of support member **384** for advancement into the pulmonary vein **PV** to provide temporary anchoring for the assembly.

[0166] Similar to the variations above, Figs. 36A and 36B illustrate perspective and side views, respectively, of another variation which utilizes an expandable membrane **380** and one or more purging ports **382** along a tapered membrane surface for positioning against an ostium of a vessel opening. This particular variation utilizes a support shaft **400** which defines a lumen opening **402** which opens at a distal end of expandable membrane **380**. Imaging element **52** may be placed along support shaft **400** within

membrane **380** and a number of various tools, such as guidewire **404**, may be passed through shaft **400** and distally of lumen opening **402** for access into the pulmonary vein **PV**.

[0167] Another variation of a visual electrode ablation system is illustrated in the respective partial cross-sectional side and end views of Figs. 37A and 37B. This particular variation may incorporate a distal membrane which defines a plurality of micro-pores or slots **410**, illustrated in Fig. 37B. As the purging fluid is introduced within hood **12** via fluid lumen **414**, the fluid may be recirculated **412** within hood **12** to provide cooling to the underlying tissue **T** contacted by the hood **12**. The fluid **412** within hood **12** may be withdrawn from hood **12** via fluid return lumen **416**. As the pressure of the fluid is increased within hood **12**, the purging fluid may seep through the micro-pores or slots **410** and into contact with the underlying visualized tissue. The electrode, either via separate electrode **174** or via a conductive support strut, may be energized to transmit a current through this fluid and into the underlying tissue through the seeped fluid. The micro-pores or slots **410** may have a diameter ranging from, e.g., 50 to 500 micrometers. Moreover, with multiple irrigation channels, the circulating fluid **412** within the hood **12** may function to cool the ablated tissue surfaces and this additional cooling feature may facilitate the formation of deeper and relatively larger lesions.

[0168] Another variation for improving the creation of lesions upon the underlying tissue is illustrated in the side and end views of Figs. 38A to 38C. In this variation, hood **12** may be positioned against the tissue surface **T** and the interior of hood **12** may be filled with the purging fluid **420**, as shown in Fig. 38A. Once the hood interior has been purged of any blood and visualization of the underlying tissue **T** is established, a negative pressure may be induced within hood **12** by withdrawing or suctioning **422** some of the purging fluid **420** proximally through infusion and/or suction lumen **424**, as shown in Fig. 38B. The tissue in contact with the purging fluid through aperture **182** (shown in Fig. 38C) may be drawn against distal membrane **184** through aperture **182** by the negative pressure such that the adhered tissue **426** may become slightly elevated and partially drawn through aperture **182**. With this seal created between the adhered tissue **426** through aperture **182**, the tissue may be ablated while under visualization from imaging element **52** and an ablation area matching the aperture **182** area may be ensured. With the relative current density over the aperture **182**, relatively deep and narrow lesions may be formed through the adhered tissue **426**.

[0169] Figs. 39A and 39B illustrate other variations of a hood **12** also configured

for creating a negative pressure within the hood interior for creating a seal between the tissue and aperture **182**. In this variation, the assembly may be configured to create a recirculating flow of fluid **430** within the hood interior once adhered to the tissue surface. As above, the hood interior may have the purging fluid introduced to clear the visualization field. With the infusion of the fluid into hood **12** at a first flow rate through a first lumen, the purging fluid may also be withdrawn from hood **12** at a second flow rate through a second lumen once the visualization field has been established. By maintaining the second flow rate for withdrawal at a relatively higher rate than the first flow rate for infusion into hood **12**, an overall negative pressure may be maintained within hood **12** which may cause the underlying tissue **426** to become adhered against aperture **182**, as illustrated in Fig. 39A, while a recirculating flow of fluid **430** is maintained within hood **12**. This recirculating flow **430** may maintain a cooling effect upon the ablated tissue. Alternatively, by maintaining a first flow rate for infusion which is relatively higher than the second flow rate for withdrawal, a considerable amount of the purging fluid may be conserved as a result of efficiently purging the hood **12**, as illustrated in Fig. 39B.

[0170] As the tissue is ablated during tissue treatments, the ability to directly and vividly visualize the ablation process without any ablation probe obstructing the visualization field may allow for visual monitoring of the ablation treatment, as illustrated in the view of the targeted tissue **440** as visible through aperture **182** along distal membrane **184** when viewed from within hood **12**. For instance, heating of tissue may result in the formation of steam within the ablated tissue and micro-bubbles **442** on the tissue surface, which is indicative of a pending endocardial disruption. If an endocardial disruption occurs, the tissue may “pop” releasing tissue debris, e.g., charred tissue fragments, coagulated blood, etc., into the environment. Endocardial disruptions and the monitoring and clearing of tissue debris within hood **12** are described in further detail in U.S. Pat. App. Serial No. 11/775,819 filed July 10, 2007, which is incorporated herein by reference in its entirety.

[0171] In this variation, as the visualized tissue is ablated through the purging fluid via a non-contacting electrode (e.g., separate electrode or conductive strut), the bubble formation **442** upon the tissue surface may be visually monitored directly and an algorithm may be employed for bubble detection which monitors the number and rate of bubble formation within the visualization field, as shown in Fig. 40B. Such an algorithm may accordingly pre-empt an endocardial disruption by automatically reducing or shutting down the power supplied to the electrode such that the underlying tissue is

ablated without popping. The algorithm may run via a processor in an attached computer or within the visual imaging processor. The ablation may continue until the underlying tissue is blanched 440' which may serve as a visual indication of transmural tissue while avoiding the formation of any bubbles 442. With the ablation completed, hood 12 may be repositioned over another tissue region for treatment or removed from the region, as shown in the perspective view of Fig. 40D.

[0172] Fig. 41 illustrates a flow chart of one example for an algorithm incorporated into software run by a processor in a computer or within the visual imaging processor which may be configured to monitor the quantity as well as the rate of bubble formation using technology such as the edge detection algorithms which are generally known in the art. In this example, once the hood has been purged to clear the visualization field 450, the underlying tissue may be visualized 452. Electrode-to-tissue contact may be confirmed 454 by sending a test charge or by visually confirming the contact. The ablation energy may then be activated to ablate the tissue under visualization 456. While ablating the tissue, the tissue surface may be visually monitored 458 by the edge detection software. If no bubbles are visually detected within the field 460, the ablation cycle time may be finished 462 and the tissue may be evaluated 464 to determine whether sufficient lesion formation has been achieved. If further tissue ablation is required, then the ablation energy may again be activated 456 and the process repeated until sufficient lesion formation has been achieved. The hood 12 may then be repositioned 466 upon a second tissue region for treatment or the hood 12 may be removed from the area.

[0173] If during the ablation treatment, the software detects the formation of bubbles 460, the software may be configured to automatically cease ablation or reduce the power supplied to the electrode 468. Alternatively, the software may instead be configured to notify the user by an alarm and the user may then directly cease ablation or reduce power accordingly. In either case, with the power ceased or reduced, the software may be further configured to detect any debris which may have been released from the tissue by a disruption or the user may simply examine the visual field for any presence of debris 470 within the field. If no tissue debris is detected, ablation may resume 456 and the process continued. However, if tissue debris is detected, hood 12 may effectively enclose and contain the debris therewithin and the fluid and debris within hood 12 may be evacuated 472 through deployment catheter 16 either by the user or automatically by the processor upon detection of the debris. Once the hood 12 interior has been cleared,

purging fluid may be re-introduced to re-establish the visualization field of the tissue being treated and ablation energy may again be activated **456** to continue the ablation process if so desired.

[0174] In reducing the power level or ceasing ablation altogether, Fig. 42 illustrates another example of an algorithm which may be used to adjust the power level accordingly. As above, once the hood **12** has been positioned upon the tissue to be treated and visualization established, ablation of the tissue may be initiated **480**. The software may monitor the visualization field to detect the quantity and/or rate of bubble formation **482**. If the quantity and/or rate of bubble formation have not exceeded a predetermined maximum allowable value, ablation may continue while being monitored. However, if the quantity and/or rate of bubble formation have exceeded the predetermined threshold value, the power level may be adjusted to be reduced **486** by a preset amount and ablation may be continued while monitoring the ablation process. If bubble formation is further detected at the lower power level and has again exceeded the predetermined value, the power level may again be lowered **486** and the process repeated until the power level has been reduced to zero **488**. If the power has been shut down automatically, the user may make a determination as to whether other tissue regions are to be ablated **490**, in which case hood **12** may be repositioned and the entire process repeated. If ablation is complete, hood **12** may then be removed from the area entirely.

[0175] Aside from visually monitoring and detecting for bubble formation, other assembly variations may additionally and/or alternatively incorporate other tissue monitoring features for use with ablation treatments for monitoring the underlying tissue before, during, and/or after an ablation treatment. An example is illustrated in the perspective view of Fig. 43, which shows hood **12** incorporating one or more electrocardiogram electrodes **500** placed upon distal membrane **184** for direct contact against the targeted tissue. Such electrocardiogram electrodes **500** may be positioned about membrane **184** and utilized for a combination of applications, such as electrode recording, pacing and ablation either simultaneously or sequentially separated by the desirable intervals of time, etc.

[0176] In other variations, in order to gain better contact with the tissue region during mapping or pacing procedures, hood **12** may incorporate at least one pair of support members **510** at the base of hood **12** within or upon distal membrane **184** on either or both sides of aperture **182** and which are biased to extend distally from hood **12** at an angle, as shown in the partial cross-sectional side view of Fig. 44A. Each support

member 510 may contain an electrode assembly 512 having an electrode 514 distally positioned upon member 510, return electrode 516 proximally of electrode 514, and an optional third electrode 518 proximally of return electrode 516, as illustrated in the detail side view of Fig. 44C. When hood 12 is pressed against the tissue region T, because members 510 are biased to extend distally at an angle relative to hood 12, the electrodes 512 on members 510 may maintain proper contact with the tissue region T as shown in the partial cross-sectional side view of Fig. 44B. The hood 12 may therefore be easily pressed against the desired tissue region T to perform electrogram mapping, pacing, and other diagnostic or therapeutic procedures.

[0177] Another variation for monitoring the tissue before, during, or after an ablation procedure is illustrated in the partial cross-sectional side view of Fig. 45, which shows hood 12 positioned against a tissue surface T and having an electrode assembly 520 on a first side of the distal membrane over hood 12 and a return electrode assembly 522 on a second opposite side of the distal membrane over hood 12. The electrode assembly 520 may conduct measurement signals 524 to the return electrode assembly 522 through the underlying tissue and across the aperture where the treated tissue resides. The detected signals 524, or lack of received signals from electrode 520, by return electrode 522 may be used to determine a condition of the tissue region between the electrodes. If no signals are received by return electrode 522, this may be an indication that the ablated tissue is dead and hence does not allow conduction of electrical signals. This additional parameter may be utilized alone or in combination with the visual images of the treated tissue in determining whether the ablation has been thorough and complete.

[0178] Another variation is illustrated in the partial cross-sectional side view of Fig. 46, which shows hood 12 having one or more ultrasonic transducers 530 positioned upon hood 12 or distal membrane 184 in contact with the underlying tissue for determining a thickness of the tissue to be ablated. For example, prior to the initiation of tissue ablation, the one or more transducers 530 may be placed against the tissue surface to be treated and ultrasonic signals may be emitted into the tissue. The emitted signals may be reflected by any underlying obstructions or tissue interfaces 534 such that the return signals 532 received by the transducer or receiver may be automatically processed by software to analyze the return signals 532 for peaks of the ultrasonic waves received and the time intervals between them to determine a thickness of the underlying tissue. The thickness of the underlying tissue may be used to identify and confirm certain anatomical structures, such as the fossa ovalis, prior to transseptal puncturing or it may be

used to assist the user in selecting a suitable power level and purging fluid flow rate in efficiently creating a lesion. The ultrasound transducers **530** can also be used to detect a distance between the hood **12** and the tissue during catheter manipulation. Before the hood **12** establishes visualization of the underlying tissue, the visual image through the hood **12** may appear red in color from, e.g., the surrounding blood environment, and the operator may not know if the hood **12** is relatively far from the tissue surface or if the hood is adjacent to the tissue surface yet is lacking a sufficient seal around the aperture or hood diameter. The ultrasound transducers **530** may thus be activated to provide this positional information to the user.

[0179] Yet another variation for monitoring the tissue for ablation treatment is illustrated in the side and perspective views, respectively, of Figs. 47A and 47B. This variation utilizes one or more thermochromic indicators along the hood **12** or distal membrane **184** which are visible to the user through the visualization field for monitoring temperature changes in either or both of the underlying tissue or the purging fluid itself. As thermochromic materials undergo color changes indicative of the surrounding temperature, the changes in color of these indicators may be correlated to the temperature changes, either visually by the user or automatically by a software algorithm.

[0180] In the examples shown, a first thermochromic indicator **540** may be positioned along the exterior of membrane **184** for contact against the underlying tissue. The color changes in first indicator **540** may be viewed and detected through the distal membrane **184**. Additionally and/or alternatively, a second thermochromic indicator **542** may be positioned along the interior of membrane **184** or along an inner surface of hood **12** to monitor temperature changes within the purging fluid itself. Examples of the color change in an indicator **542** are shown in the end views of Figs. 48A to 48D. As illustrated, a first color of indicator **542'** may be indicative of a first temperature level of the fluid within hood **12**. As ablation treatment progresses and the fluid temperature rises within hood **12**, indicator may change to a second color **542''** indicative of a second higher temperature level, and to a third color **542'''** indicative of a third higher temperature level, and to yet a fourth color **542''''** indicative of still a fourth higher temperature level, and so on. In this manner, temperature levels may be monitored visually.

[0181] An algorithm may be employed to correlate the observed color of the thermochromic indicator to a corresponding temperature of the region surrounding the thermochromic indicator. An automated software program employing the algorithm may

be used to automatically detect the color of the thermochromic indicator and calculate the corresponding temperature and display it to the user. An automatic system may be used to regulate or switch off the power supplied to the purging fluid if the calculated temperature is close to exceeding the safe temperature limit. The example of Fig. 49 illustrates a flowchart where once the target tissue has been visually identified, ablation may proceed 550. The color the thermochromic indicator may accordingly be monitored 552 and based upon the color and correlated temperature level, a determination may be made as to whether the temperature is in a desirable range 554. If so, then the ablation may proceed while any color changes and correlated temperature are monitored. If the temperature has exceeded the desirable range 554, then the power supply may be automatically adjusted or lowered until a desirable color of the thermochromic indicator, and hence the temperature, has dropped below that level 556.

[0182] The applications of the disclosed invention discussed above are not limited to certain treatments or regions of the body, but may include any number of other treatments and areas of the body. Modification of the above-described methods and devices for carrying out the invention, and variations of aspects of the invention that are obvious to those of skill in the arts are intended to be within the scope of this disclosure. Moreover, various combinations of aspects between examples are also contemplated and are considered to be within the scope of this disclosure as well.

CLAIMS

What is claimed is:

1. A tissue ablation apparatus adapted for deployment within a blood-filled environment, comprising:
 - a barrier or membrane projecting from a deployment catheter and defining a field when the barrier or membrane is expanded in the blood-filled environment from an insertion configuration to a deployed configuration, wherein the barrier or membrane further defines at least one aperture through which fluid is permeable; and
 - an electrode coupled to a purging fluid within the barrier or membrane and spaced from the aperture such that, in use, electrical energy from the electrode is conducted by the fluid into the tissue surface adjacent the aperture.
2. The apparatus of claim 1 wherein the barrier or membrane defines a conical structure.
3. The apparatus of claim 1 wherein the transparent fluid comprises saline.
4. The apparatus of claim 1 wherein the barrier or membrane forms an expandable membrane defining an angled contact surface relative to the catheter.
5. The apparatus of claim 1 wherein the barrier or membrane comprises a distal membrane along which the aperture is defined.
6. The apparatus of claim 1 further comprising a handle coupled to a proximal end of the deployment catheter.
7. The apparatus of claim 1 further comprising an imaging element positioned within or along the barrier or membrane and adapted to image a tissue surface adjacent to the barrier or membrane when the field is purged of blood via the purging fluid.
8. The apparatus of claim 7 wherein the barrier or membrane define one or more directional indicators visible through the field via the imaging element, wherein a handle coupled to the catheter further defines one or more directional indicators correlating to the directional indicators on the barrier or membrane such that articulation of a control on the

handle articulates the deployment catheter in a corresponding direction.

9. The apparatus of claim 7 wherein the barrier or membrane define one or more gradations visible through the field via the imaging element.

10. The apparatus of claim 1 wherein the electrode is positioned within the barrier or membrane proximally of the field.

11. The apparatus of claim 1 wherein the electrode is configured as a support strut positioned along the barrier or membrane.

12. The apparatus of claim 1 wherein the electrode is configured as a ring electrode extending from a support member positioned within the field proximally of the aperture.

13. The apparatus of claim 1 wherein the electrode is configured as a ring electrode positioned upon a surface of the barrier or membrane proximal to the aperture.

14. The apparatus of claim 1 further comprising an electrocardiogram electrode positioned along an outer surface of the barrier or membrane for contacting the tissue region.

15. The apparatus of claim 1 further comprising one or more ultrasound transducers along an outer surface of the barrier or membrane for contacting the tissue region.

16. The apparatus of claim 1 wherein the deployment catheter comprises a proximal steering section configured to articulate within a plane and a distal steering section configured to articulate within at least four planes.

17. The apparatus of claim 1 further comprising at least one thermochromic indicator along a surface of the barrier or membrane for visually indicating a temperature change of the transparent fluid and/or tissue surface.

18. A tissue ablation system adapted for ablating a target tissue region within a blood-filled environment, the target tissue region disposed along a tissue surface, the ablation system comprising:

a deployment catheter having a fluid lumen, an electrode, and an imaging element;
a fluid source in fluid communication with the fluid lumen so as to direct fluid distally through the fluid lumen and into a visualization field extending between the imaging element and the target tissue;

an imaging monitor coupled to the imaging element so as to image the tissue surface through the fluid within the visualization field; and

an electrical energy source coupled to the electrode, the electrode coupled to the fluid from the lumen so that the fluid within the visualization field conducts ablating electrical energy to the target tissue region.

19. The system of claim 18 wherein the deployment catheter has a flexible intracardial catheter body, and further comprising a steering system coupled to the deployment catheter so as to selectively bend the catheter body and reposition the visualization field from a proximal end of the deployment catheter when the distal end of the deployment catheter is disposed in a chamber of a heart.

20. A method of ablating a tissue region within a blood-filled environment, comprising:

restraining a fluid within a visualization field in a portion of the blood-filled environment;

visualizing the tissue region through the fluid within the visualization field; and
transmitting ablating electrical energy from the fluid into the visualized tissue region .

21. The method of claim 20 wherein the tissue region comprises a target tissue surface region within a chamber of a heart, wherein the target surface region is visualized during ablation and while the heart is beating, and wherein the fluid is restrained by a membrane or barrier, and further comprising:

expanding the membrane or barrier from an insertion configuration to a deployed configuration within the chamber of the heart, and

positioning an aperture of the membrane or barrier in alignment with the target

tissue surface region so that fluid is exposed to the tissue region and so that the ablating mitigates an arrhythmia of the heart.

22. The method of claim 21 wherein positioning comprises intravascularly advancing the barrier or membrane into a chamber of a heart.

23. The method of claim 20 further comprising monitoring a change in color of the tissue region whereby a blanched color is indicative of lesion formation.

24. The method of claim 20 further comprising monitoring the tissue region for formation of bubbles.

25. The method of claim 24 further comprising monitoring a quantity and/or rate of bubble formation.

26. The method of claim 25 further comprising automatically adjusting a power level of the electrical energy based upon the quantity and/or rate of bubble formation.

27. The method of claim 20 wherein visualizing comprises inspecting the tissue region for discontinuous lesion formations.

28. The method of claim 27 wherein transmitting comprises transmitting electrical energy through an aperture along one or more gaps between discontinuous lesions.

29. The method of claim 20 further comprising monitoring a thermochromic indicator positioned upon the barrier or membrane for changes in temperature.

30. The method of claim 29 further comprising adjusting a power level of the electrical energy based upon the changes in temperature.

31. The method of claim 20 wherein restraining comprises creating a negative pressure within the visualization field such that the tissue region is adhered to the aperture.

32. The method of claim 31 further comprising recirculating the transparent fluid within the visualization field.

33. A tissue ablation apparatus adapted for deployment within a blood-filled environment, comprising:

a barrier or membrane projecting from a deployment catheter and defining a visualization field when the barrier or membrane is in a deployed configuration, wherein the barrier or membrane further defines at least one aperture through which fluid is permeable;

an imaging element positioned within or along the barrier or membrane and adapted to image a tissue surface adjacent to the barrier or membrane within a field of view of the imaging element when the visualization field is purged of blood via a transparent fluid; and

an electrode positioned within or along the barrier or membrane such that the electrode is outside the field of view and spaced from the aperture such that energy discharged from the electrode is directed through the transparent fluid and into the tissue surface being visualized.

34. The apparatus of claim 33 wherein the barrier or membrane defines a conical structure.

35. The apparatus of claim 33 wherein the transparent fluid comprises saline.

36. The apparatus of claim 33 wherein the barrier or membrane forms an expandable membrane defining an angled contact surface relative to the catheter.

37. The apparatus of claim 33 wherein the barrier or membrane comprises a distal membrane along which the aperture is defined.

38. The apparatus of claim 33 further comprising a handle coupled to a proximal end of the deployment catheter.

39. The apparatus of claim 38 wherein the barrier or membrane define one or

more directional indicators visible through the visualization field via the imaging element, wherein the handle further defines one or more directional indicators correlating to the directional indicators on the barrier or membrane such that articulation of a control on the handle articulates the deployment catheter in a corresponding direction.

40. The apparatus of claim 33 wherein the barrier or membrane define one or more gradations visible through the visualization field via the imaging element.

41. The apparatus of claim 33 wherein the electrode is positioned within the barrier or membrane proximally of the visualization field.

42. The apparatus of claim 33 wherein the electrode is configured as a support strut positioned along the barrier or membrane.

43. The apparatus of claim 33 wherein the electrode is configured as a ring electrode extending from a support member positioned within the visualization field proximally of the aperture.

44. The apparatus of claim 33 wherein the electrode is configured as a ring electrode positioned upon a surface of the barrier or membrane proximal to the aperture.

45. The apparatus of claim 33 further comprising an electrocardiogram electrode positioned along an outer surface of the barrier or membrane for contacting the tissue region.

46. The apparatus of claim 33 further comprising one or more ultrasound transducers along an outer surface of the barrier or membrane for contacting the tissue region.

47. The apparatus of claim 33 wherein the deployment catheter comprises a proximal steering section configured to articulate within a plane and a distal steering section configured to articulate within at least four planes.

48. The apparatus of claim 33 further comprising at least one thermochromic

indicator along a surface of the barrier or membrane for visually indicating a temperature change of the transparent fluid and/or tissue surface.

49. A tissue ablation apparatus adapted for ablating a tissue region within an isolated region contained in a blood-filled environment, comprising:

a barrier or membrane projecting from a deployment catheter and defining a therapy field when the barrier or membrane is in a deployed configuration, wherein the barrier or membrane further defines at least one aperture therethrough;

an electrode positioned within or along the barrier or membrane and spaced from the aperture,

wherein the aperture is positionable against a tissue region to be ablated such that an electrolytic fluid introduced through the catheter and into the therapy field forms a conductive path between the electrode and the tissue region through the aperture, and

wherein energy delivered through the electrolytic fluid to the tissue region is contained within the therapy field of the barrier or membrane.

50. The apparatus of claim 49 wherein the electrolytic fluid comprises saline.

51. The apparatus of claim 49 wherein the barrier or membrane comprises a distal membrane along which the aperture is defined.

52. The apparatus of claim 49 wherein the electrode is positioned within the barrier or membrane proximally of the therapy field.

53. The apparatus of claim 49 wherein the electrode is configured as a support strut positioned along the barrier or membrane.

54. The apparatus of claim 49 wherein the electrode is configured as a ring electrode extending from a support member positioned within the therapy field proximally of the aperture.

55. The apparatus of claim 49 wherein the electrode is configured as a ring electrode positioned upon a surface of the barrier or membrane proximal to the aperture.

56. The apparatus of claim 49 further comprising an imaging element positioned within or along the barrier or membrane and adapted to image a tissue surface adjacent to the barrier or membrane when the therapy field is purged of blood via the electrolytic fluid.

57. The apparatus of claim 49 wherein the barrier or membrane comprises a distal membrane with a surface area at least twice as large as a cross sectional area of the deployment catheter.

58. A tissue ablation apparatus adapted for ablating a tissue region within a blood-filled environment, comprising:

a barrier or membrane projecting from a deployment catheter and defining a therapy field when the barrier or membrane is in a deployed configuration, wherein the barrier or membrane further defines at least one aperture therethrough;

an electrode positioned within or along the barrier or membrane and spaced from the aperture, and

wherein energy delivered from the electrode and through an electrolytic fluid introduced through the catheter within the therapy field enters the tissue region uniformly over an area isolated by the barrier or membrane against the tissue region.

59. The apparatus of claim 58 wherein the electrolytic fluid comprises saline.

60. The apparatus of claim 58 wherein the tissue region area isolated by the barrier or membrane is at least twice as large as a cross sectional area of the deployment catheter.

61. The apparatus of claim 58 wherein the barrier or membrane comprises a distal membrane along which the aperture is defined.

62. The apparatus of claim 58 wherein the electrode is positioned within the barrier or membrane proximally of the therapy field.

63. The apparatus of claim 58 wherein the electrode is configured as a support strut positioned along the barrier or membrane.

64. The apparatus of claim 58 wherein the electrode is configured as a ring electrode extending from a support member positioned within the therapy field proximally of the aperture.

65. The apparatus of claim 58 wherein the electrode is configured as a ring electrode positioned upon a surface of the barrier or membrane proximal to the aperture.

66. The apparatus of claim 58 further comprising an imaging element positioned within or along the barrier or membrane and adapted to image a tissue surface adjacent to the barrier or membrane when the therapy field is purged of blood via the electrolytic fluid.

67. A method of ablating a target tissue region, the target tissue region being disposed along a tissue surface, the method comprising selectively directing ablating energy into the target tissue region through the tissue surface while imaging the tissue surface along the target tissue region.

68. An apparatus for ablating a target tissue region, the target tissue region being disposed along a tissue surface, the apparatus comprising:

means for selectively directing ablating energy into the target tissue region through the tissue surface; and

means for imaging the tissue surface along the target tissue region while selectively directing the ablating energy, the imaging means coupled to the energy directing means.

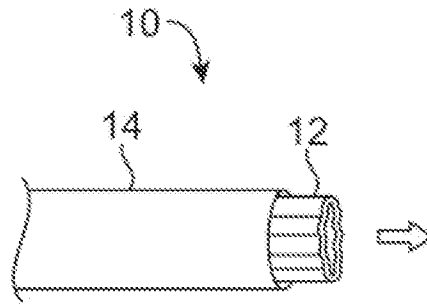

FIG. 1A

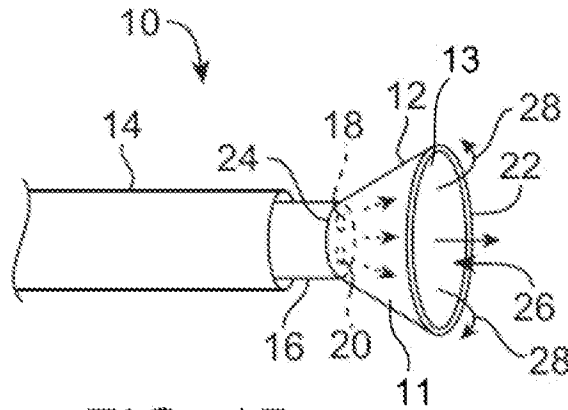

FIG. 1B

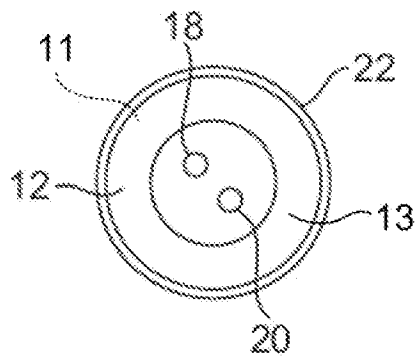

FIG. 1C

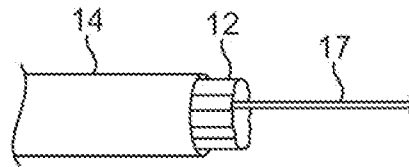

FIG. 1D

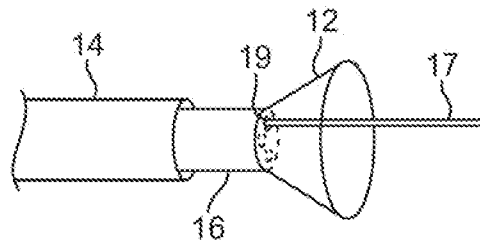

FIG. 1E

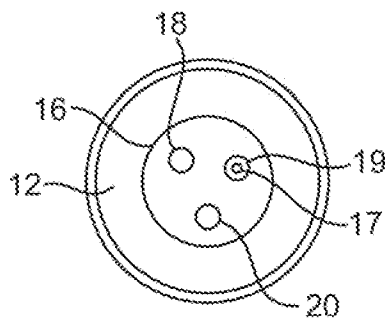

FIG. 1F

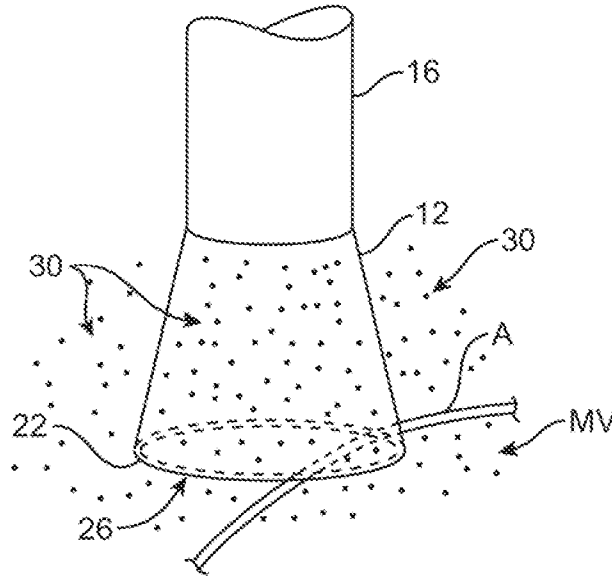

FIG. 2A

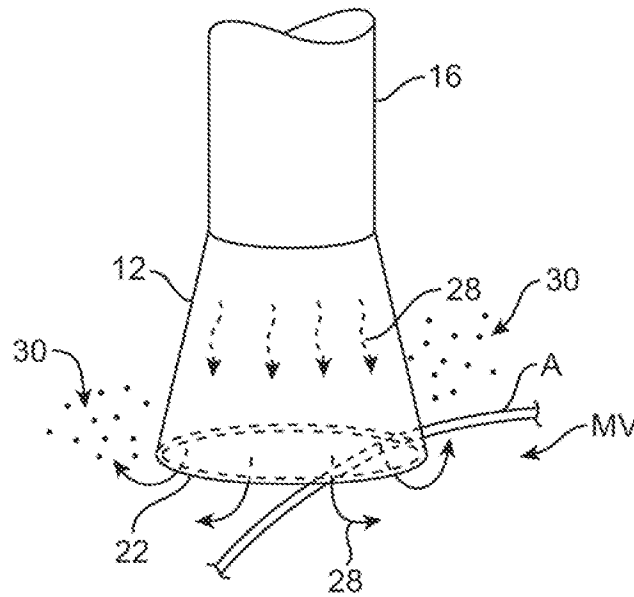

FIG. 2B

+

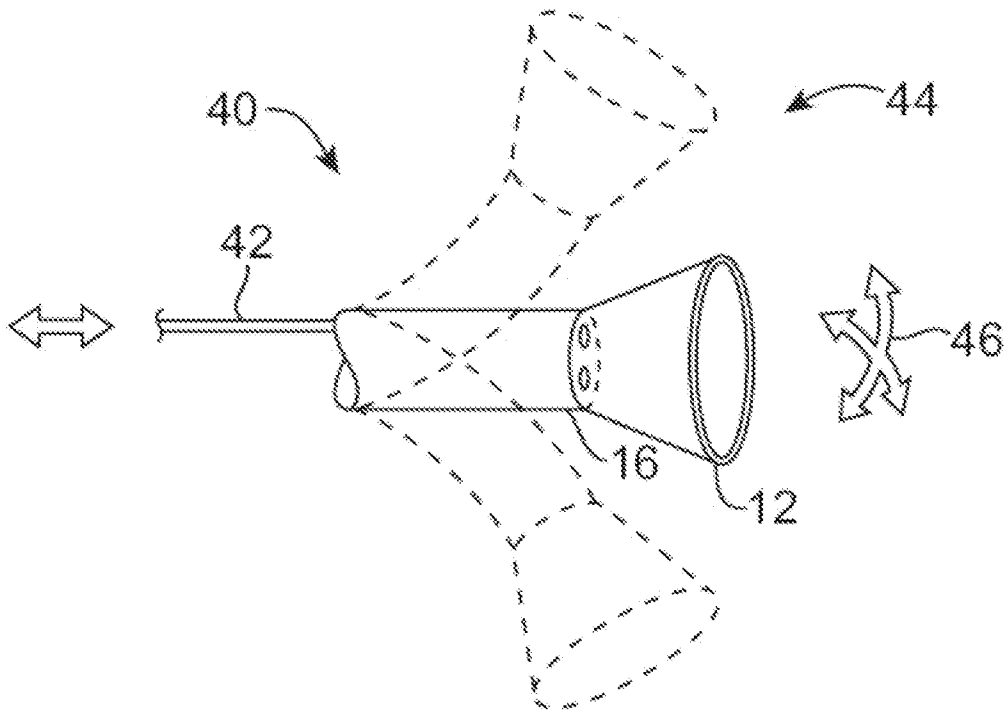

FIG. 3A

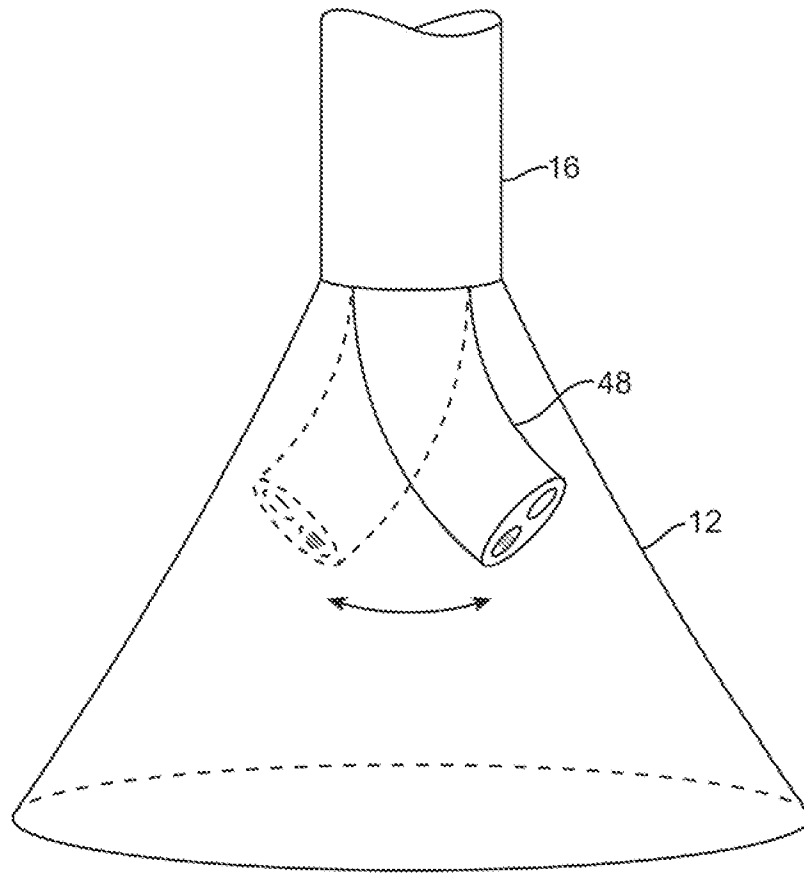

FIG. 3B

+

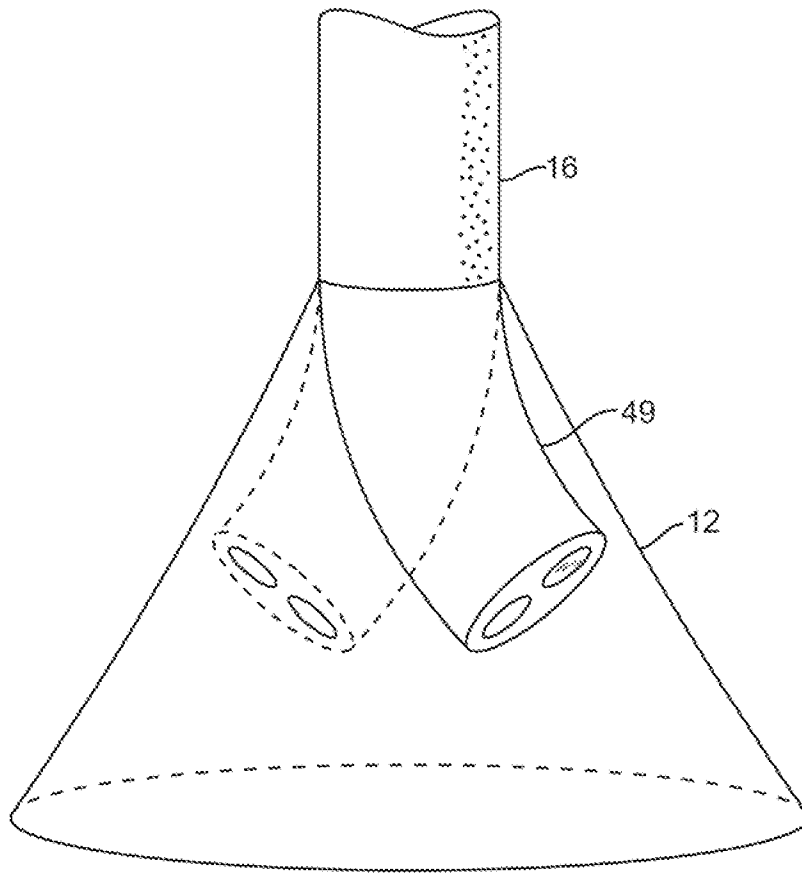

FIG. 3C

+

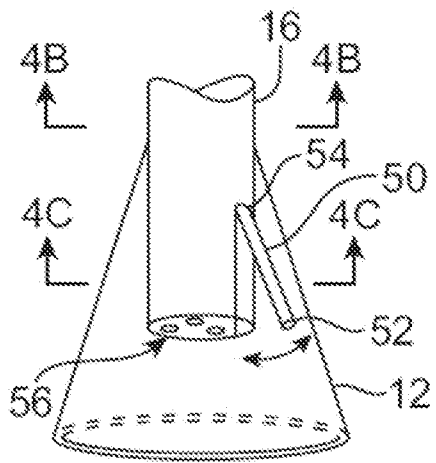

FIG. 4A

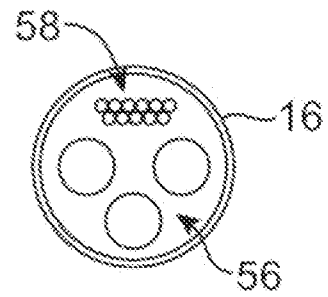

FIG. 4B

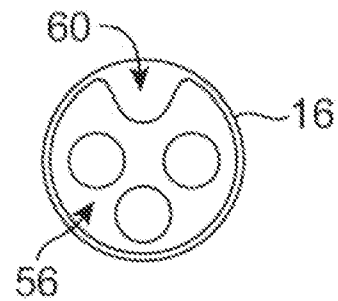

FIG. 4C

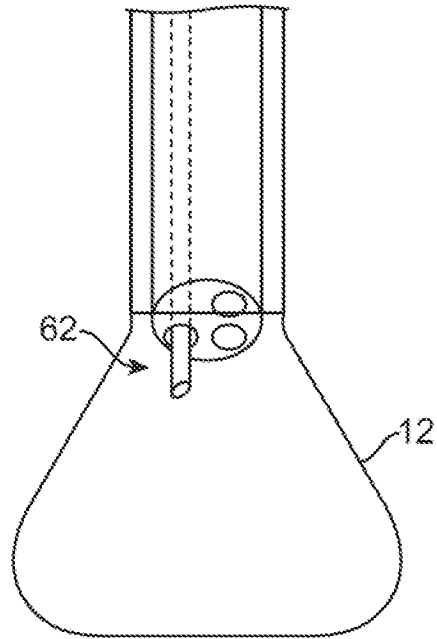

FIG. 4D

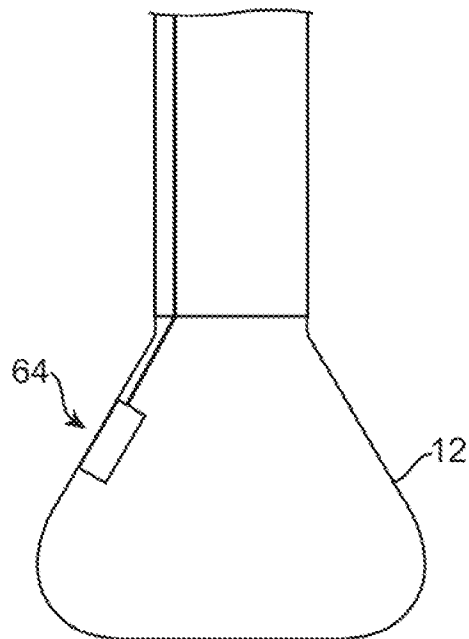

FIG. 4E

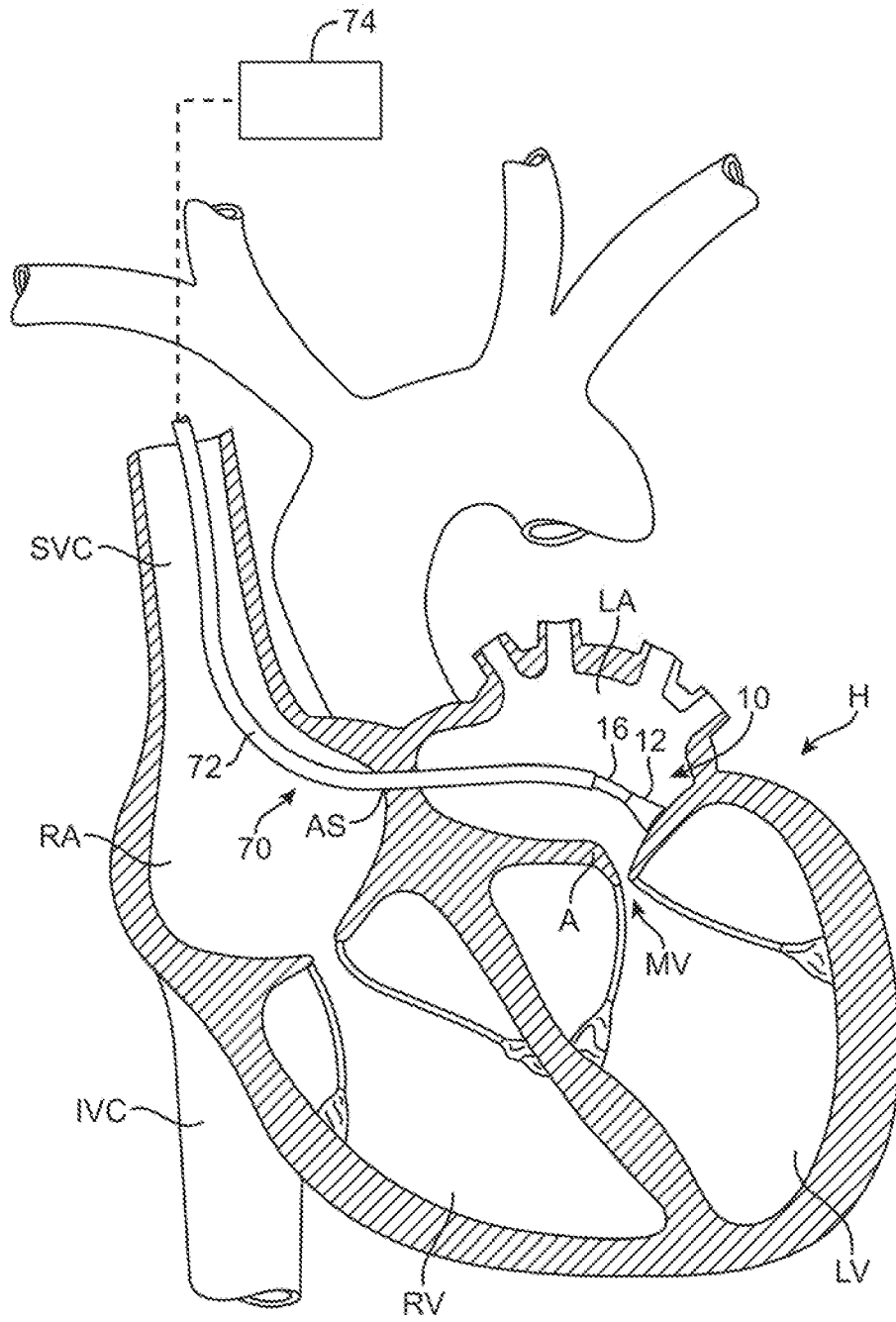

FIG. 5

+

10/52

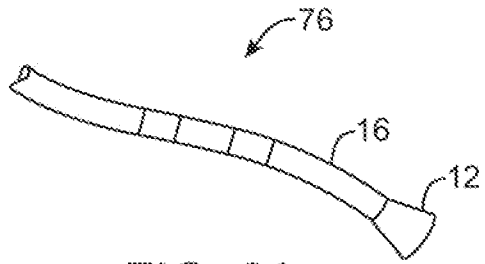

FIG. 6A

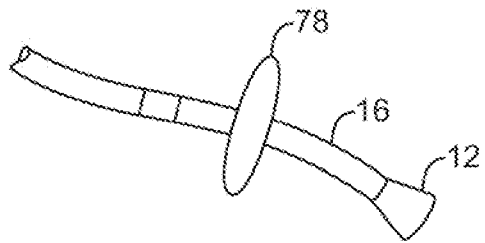

FIG. 6B

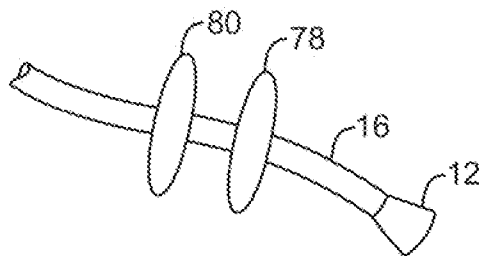

FIG. 6C

+

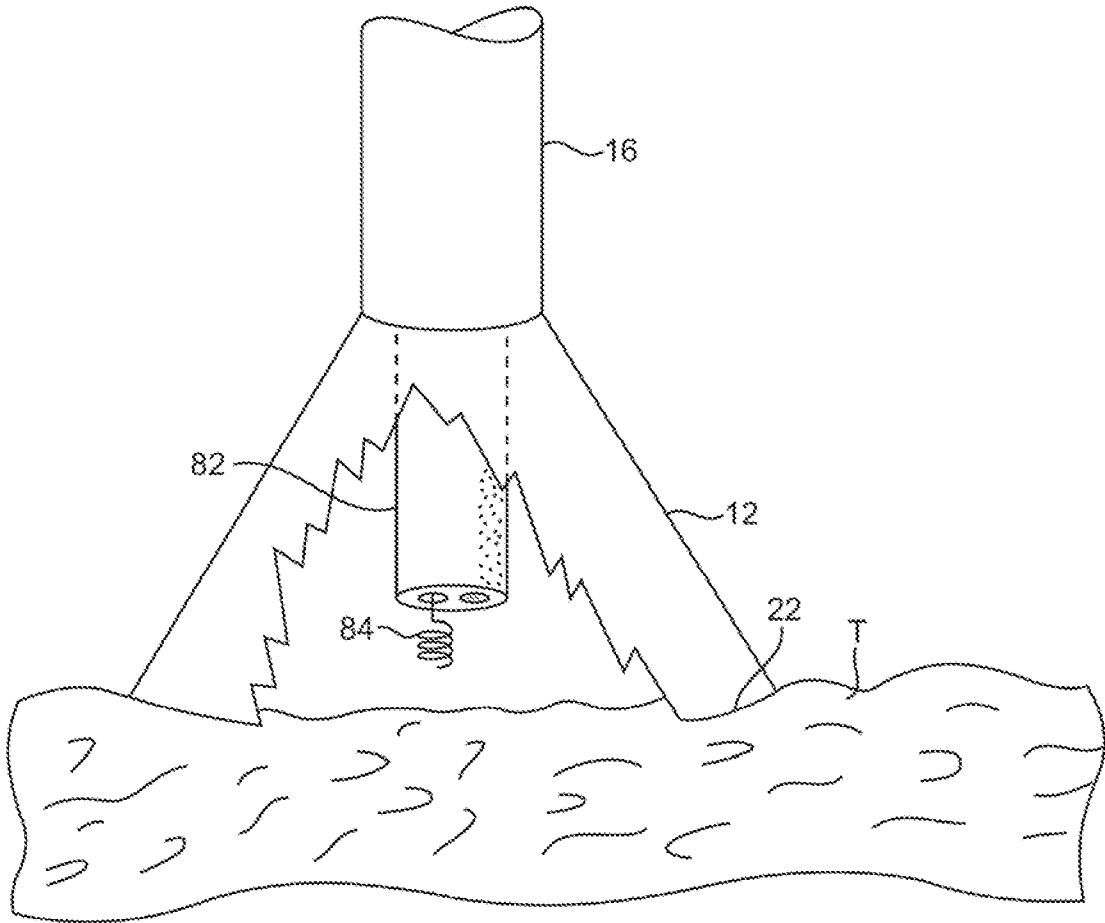

FIG. 7A

+

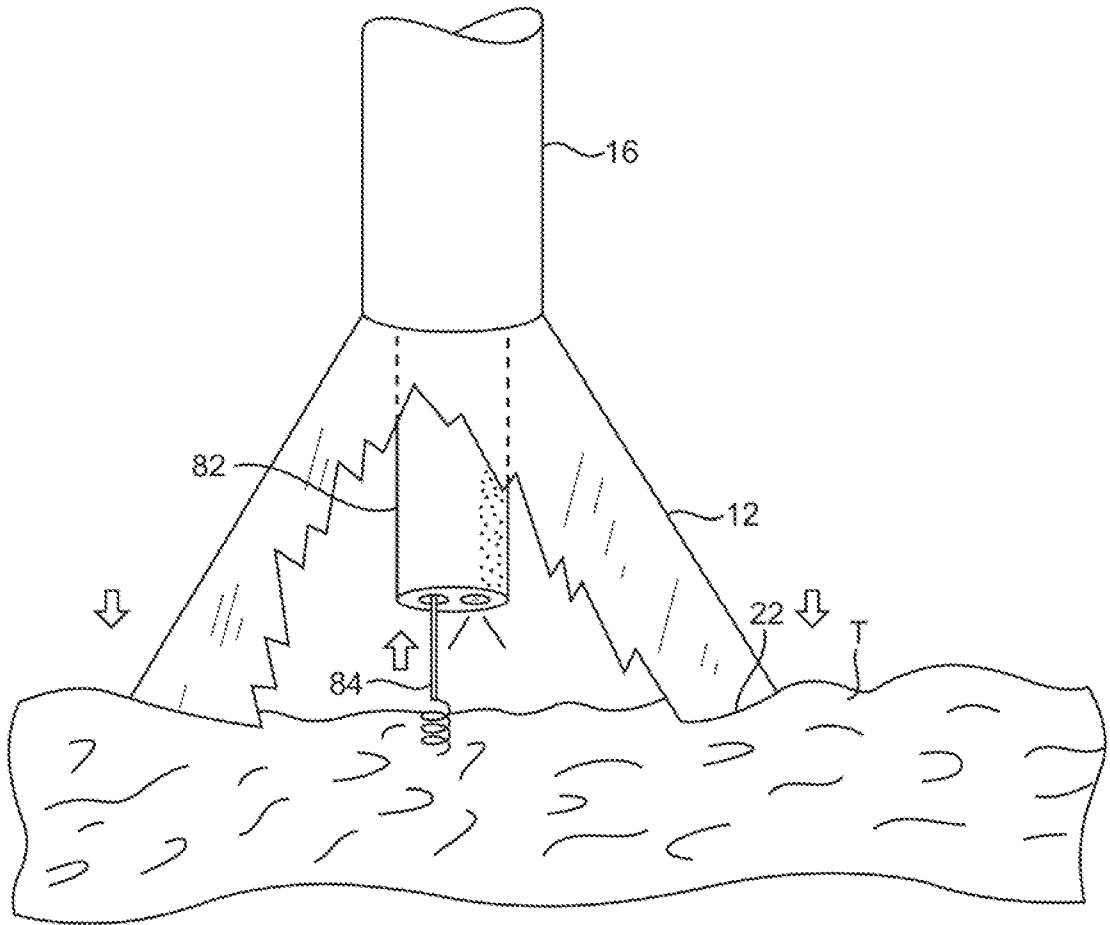

FIG. 7B

+

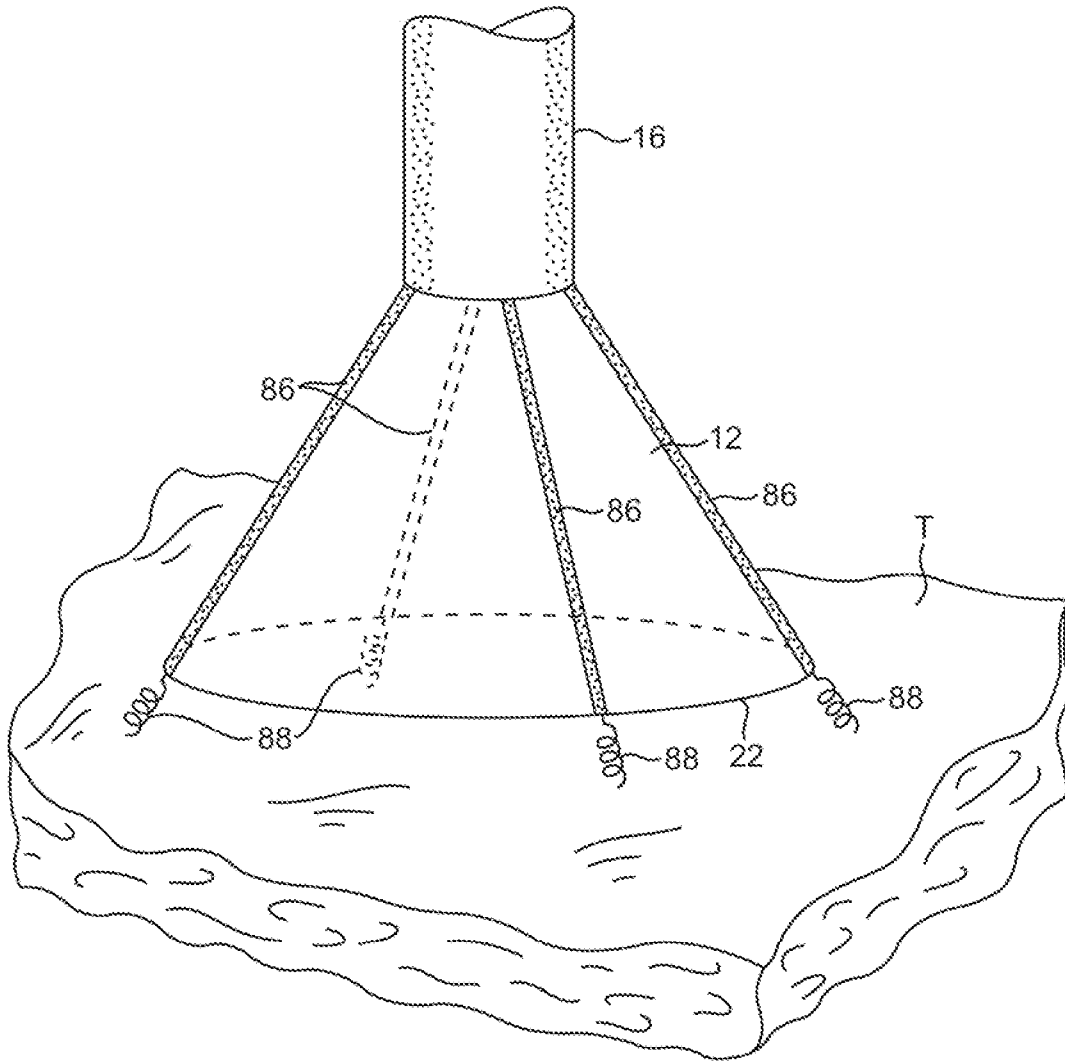

FIG. 7C

+

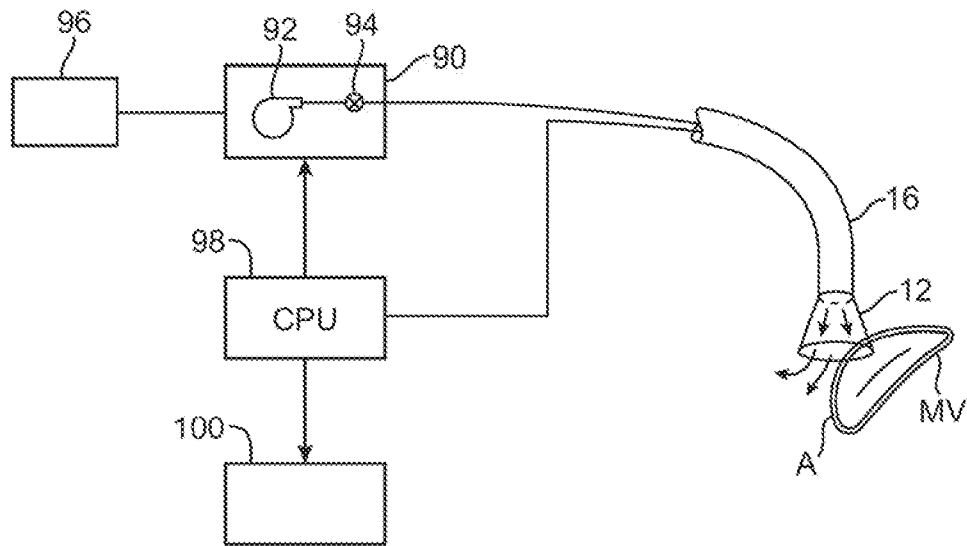

FIG. 8A

+

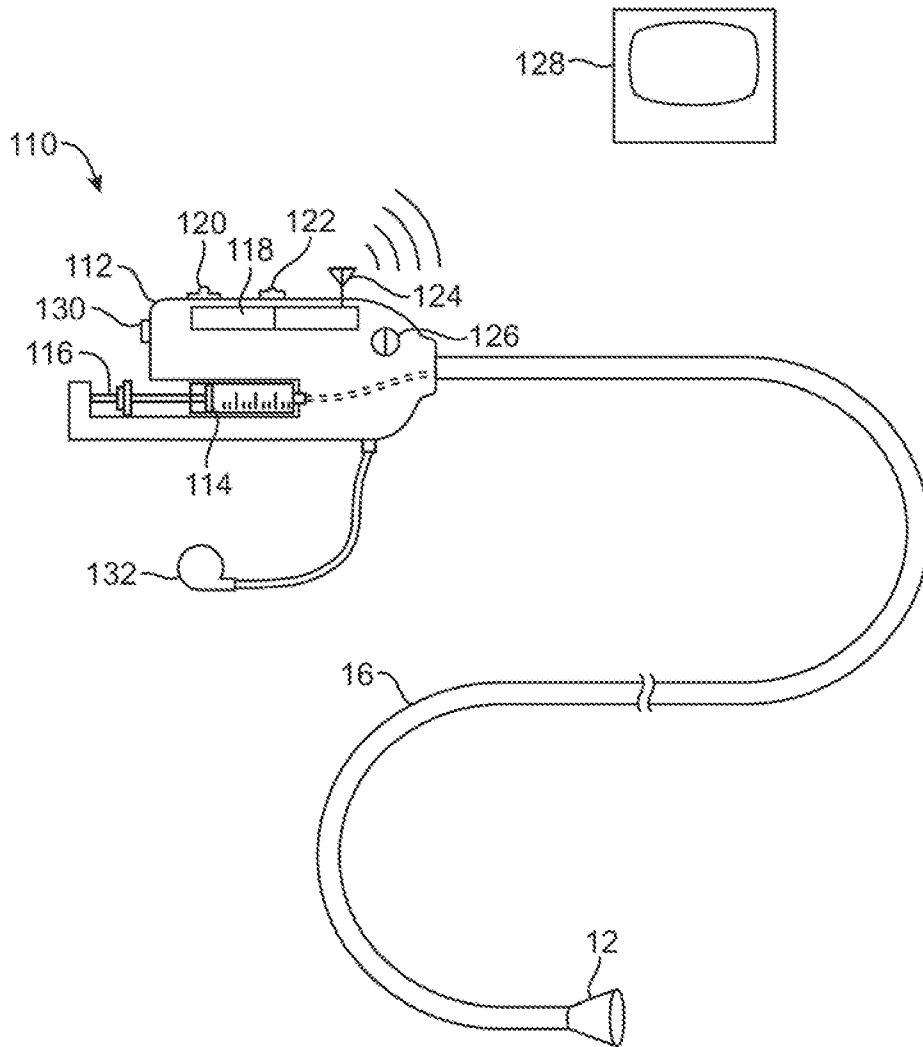
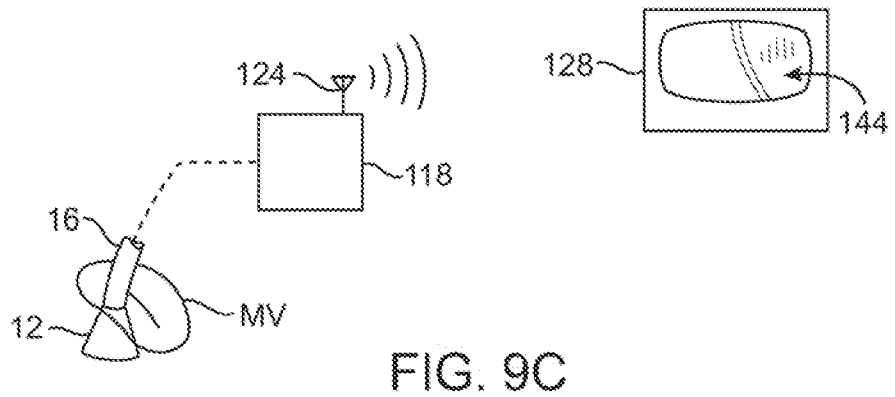
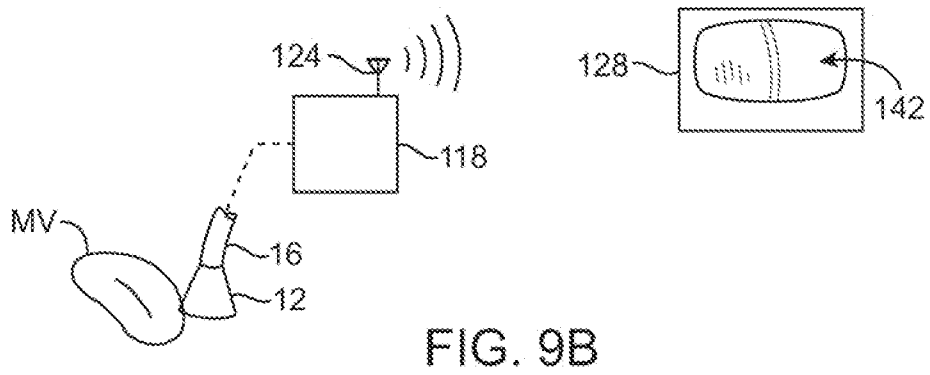
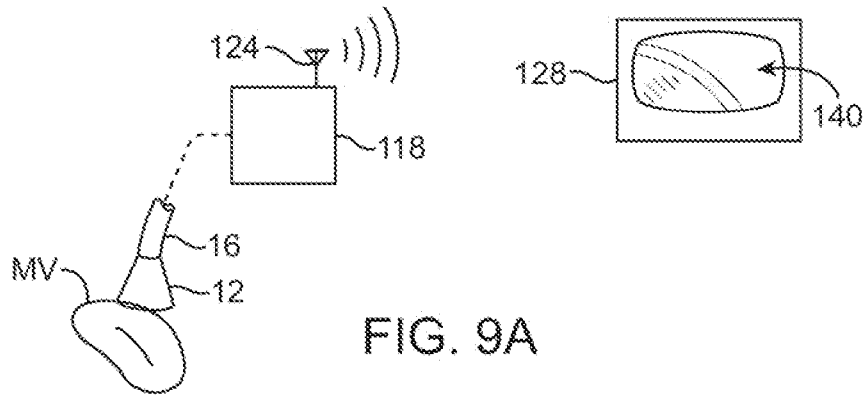

FIG. 8B

+



+

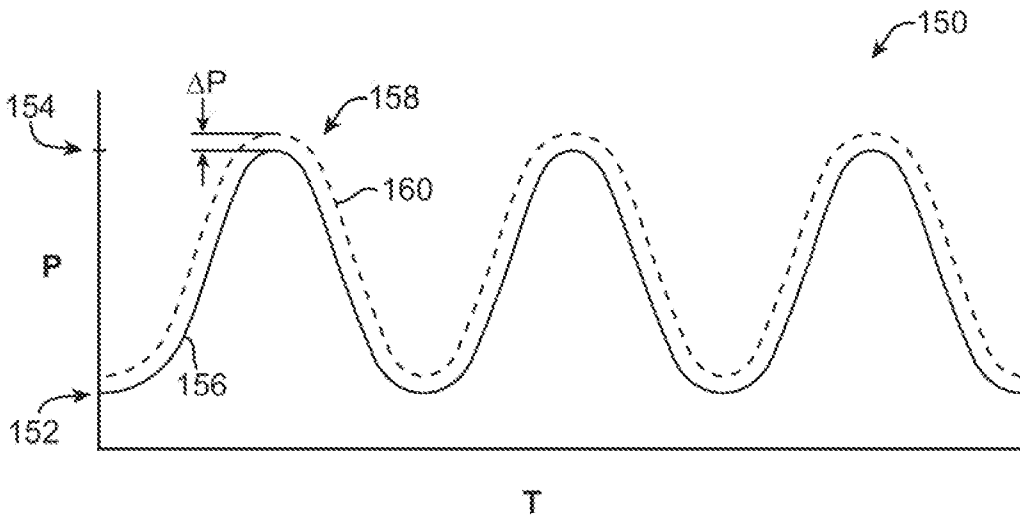

FIG. 10A

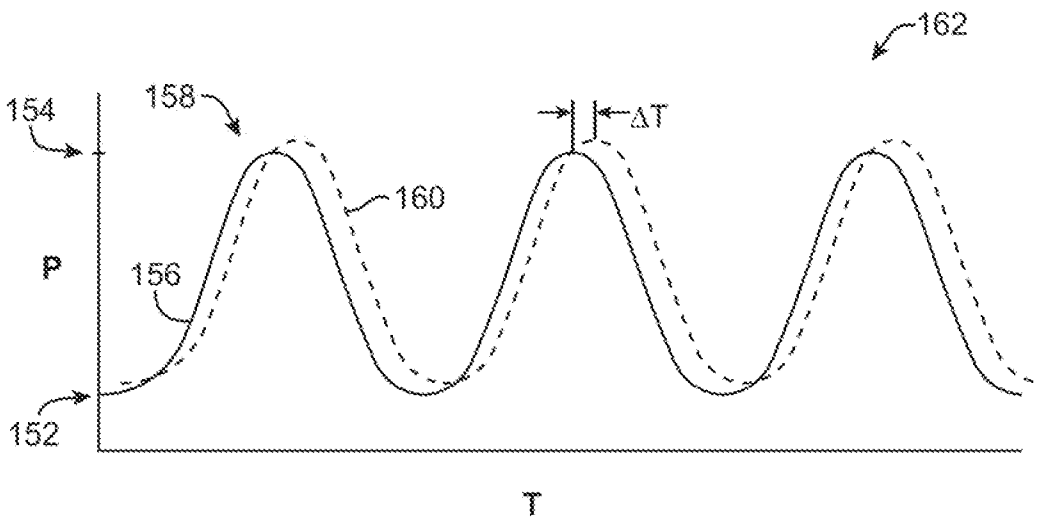

FIG. 10B

+

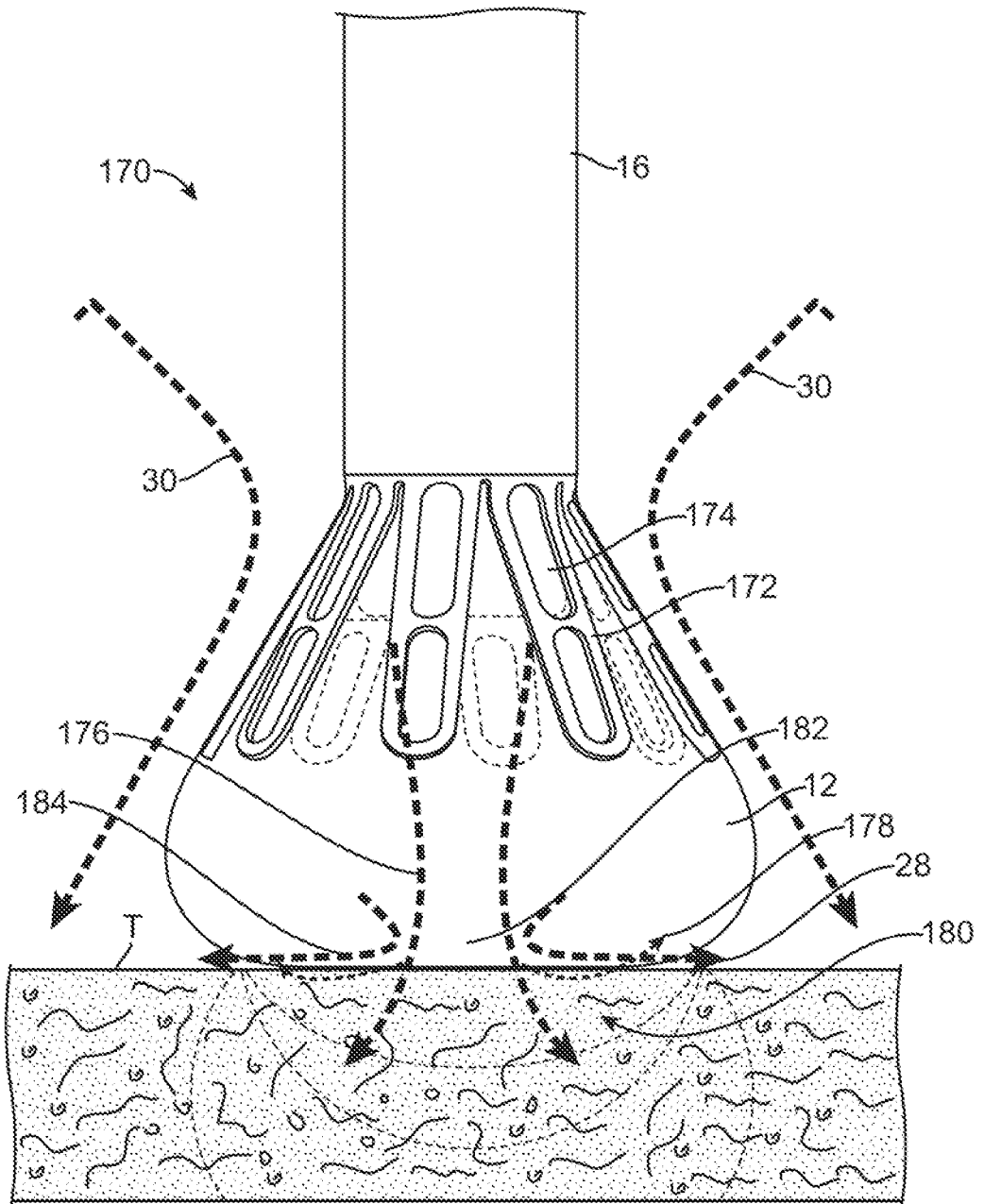

FIG. 11

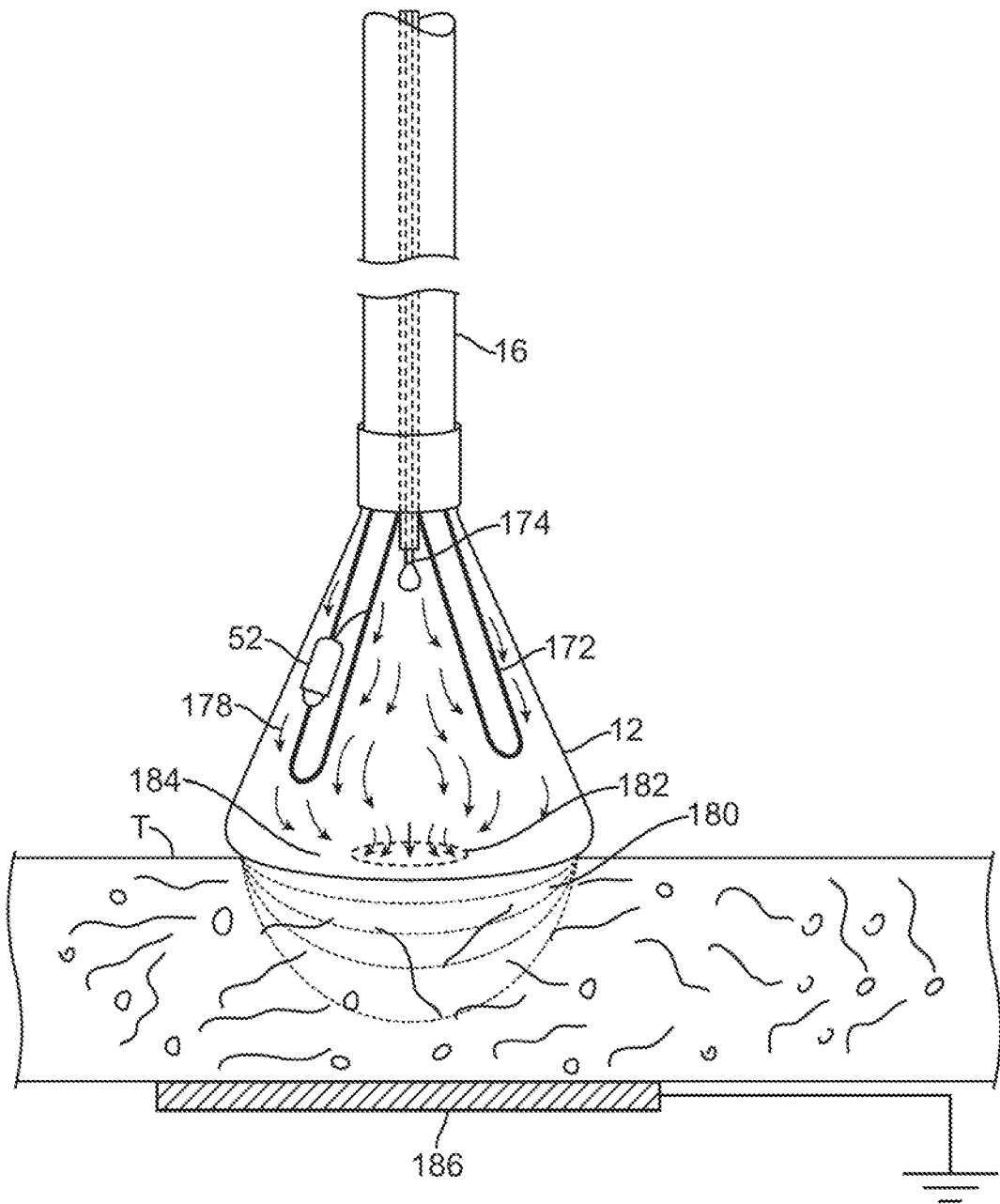
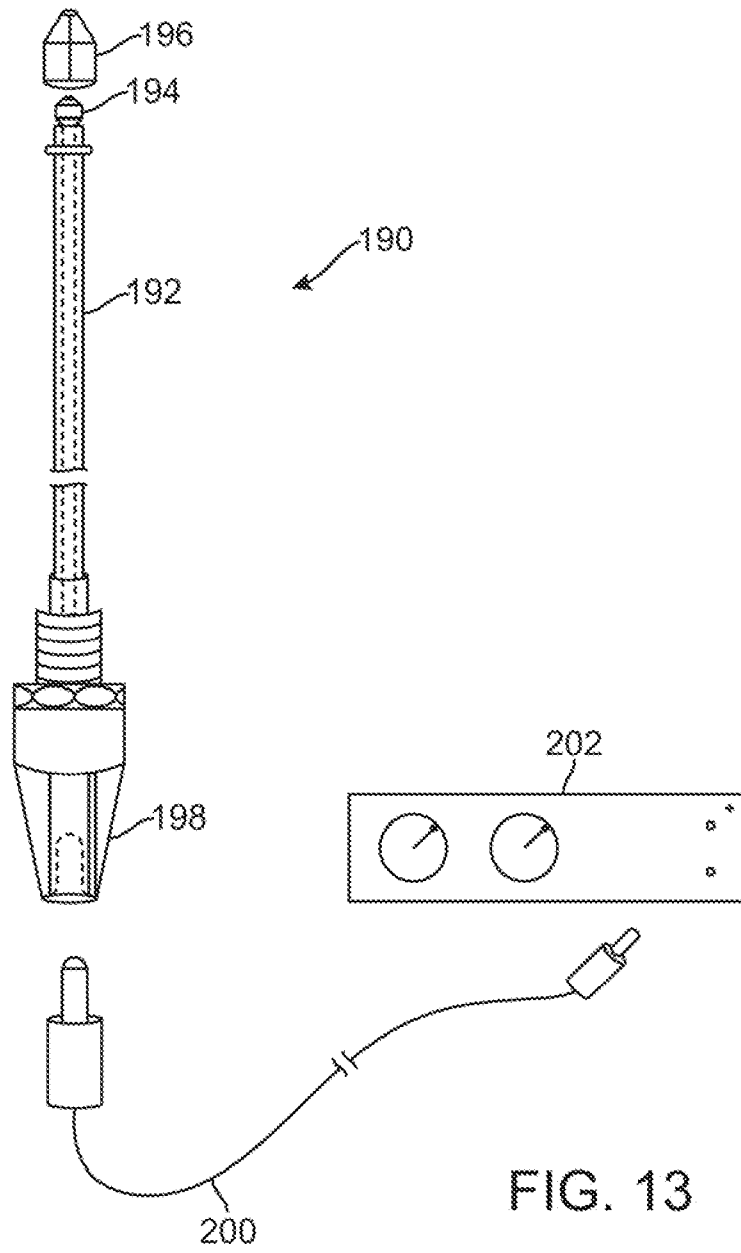

FIG. 12



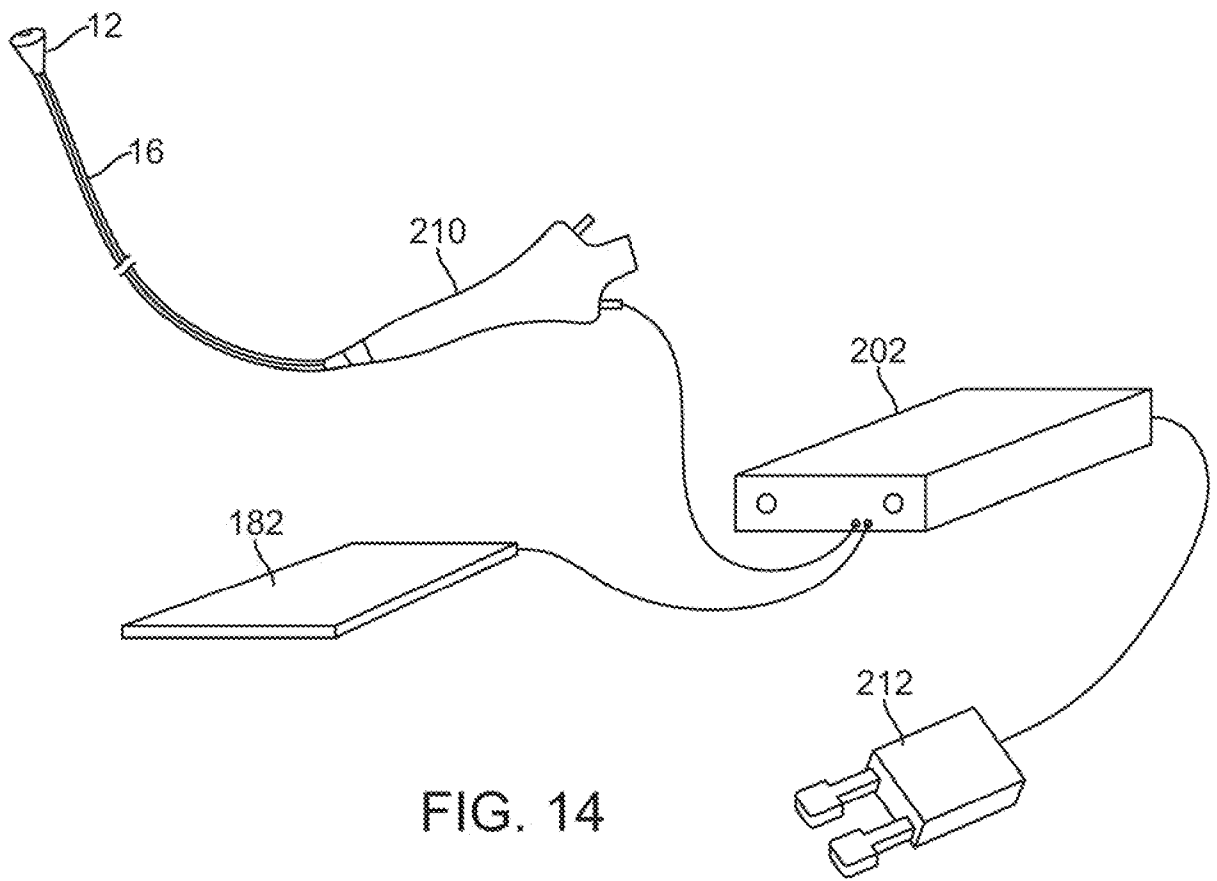

FIG. 14

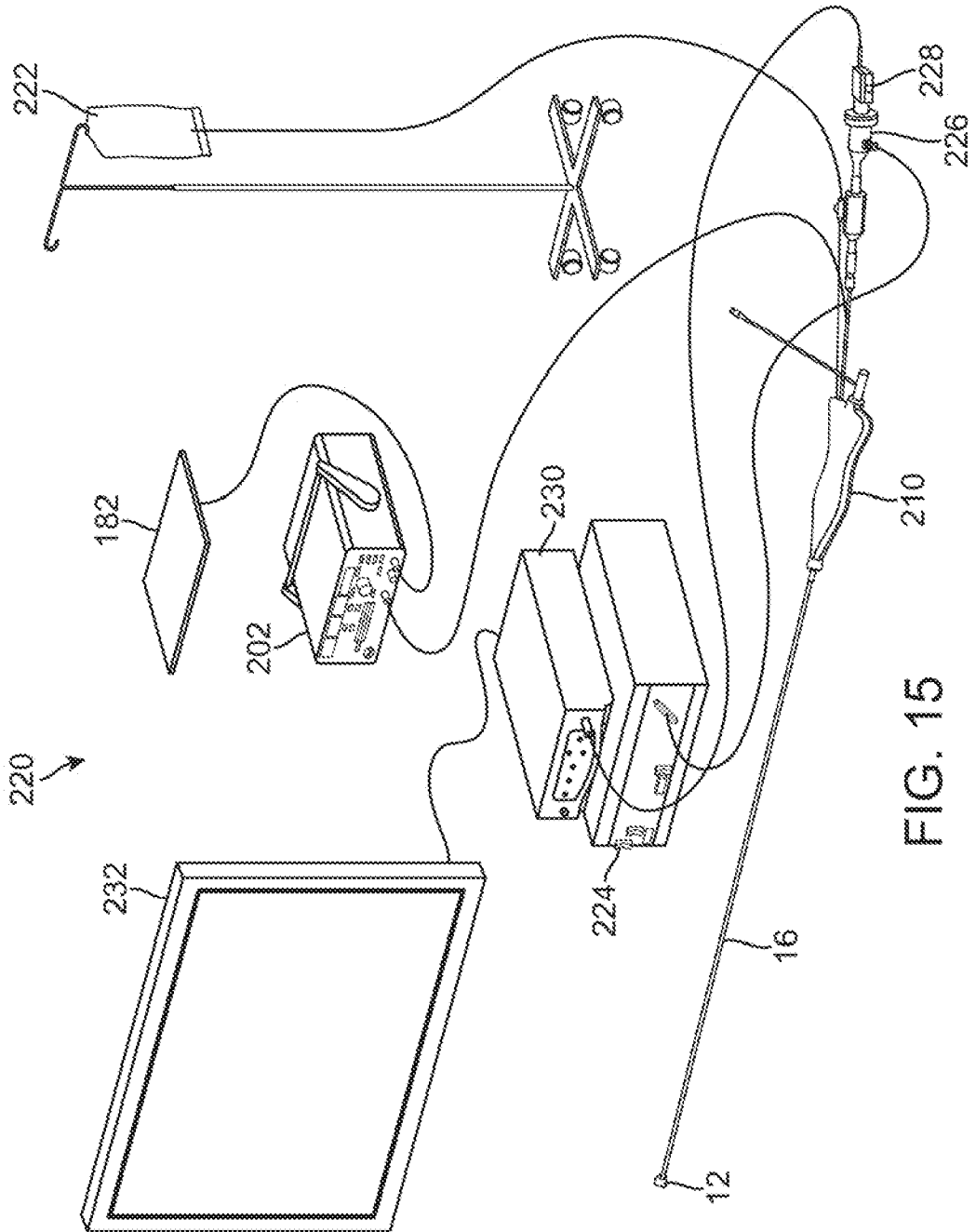
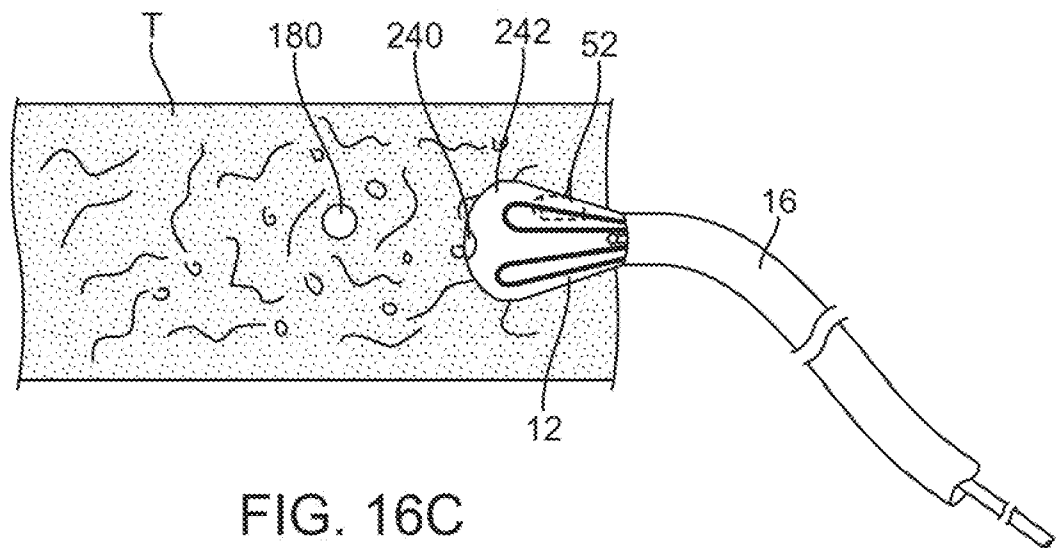
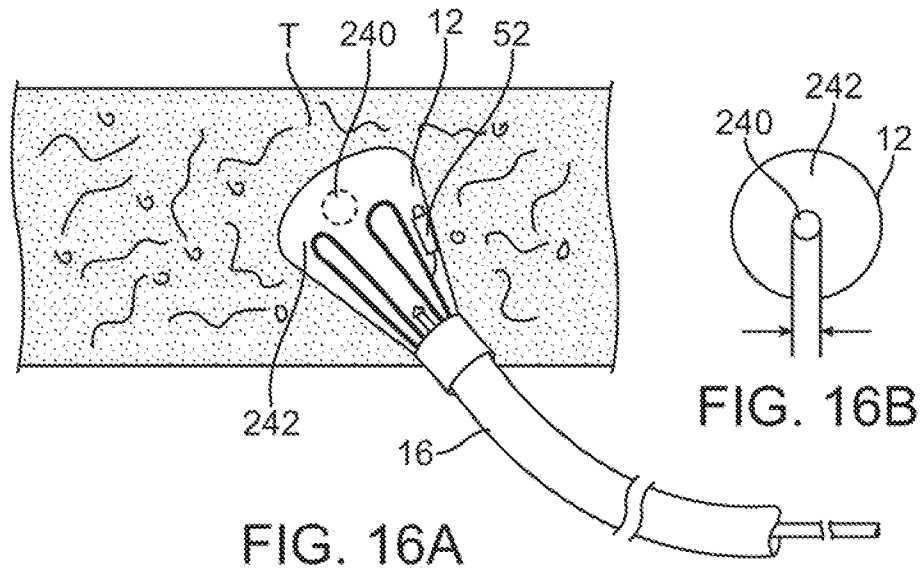

FIG. 15



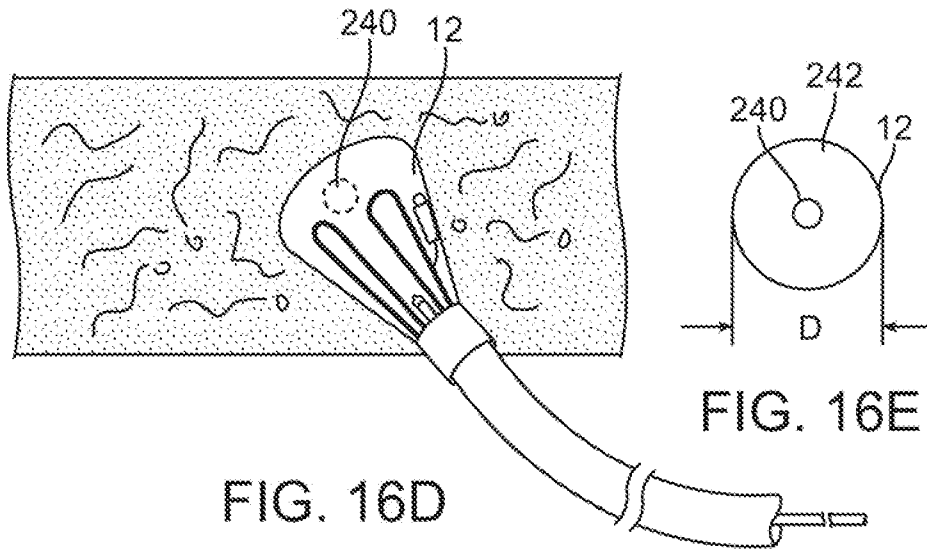

FIG. 16D

FIG. 16E

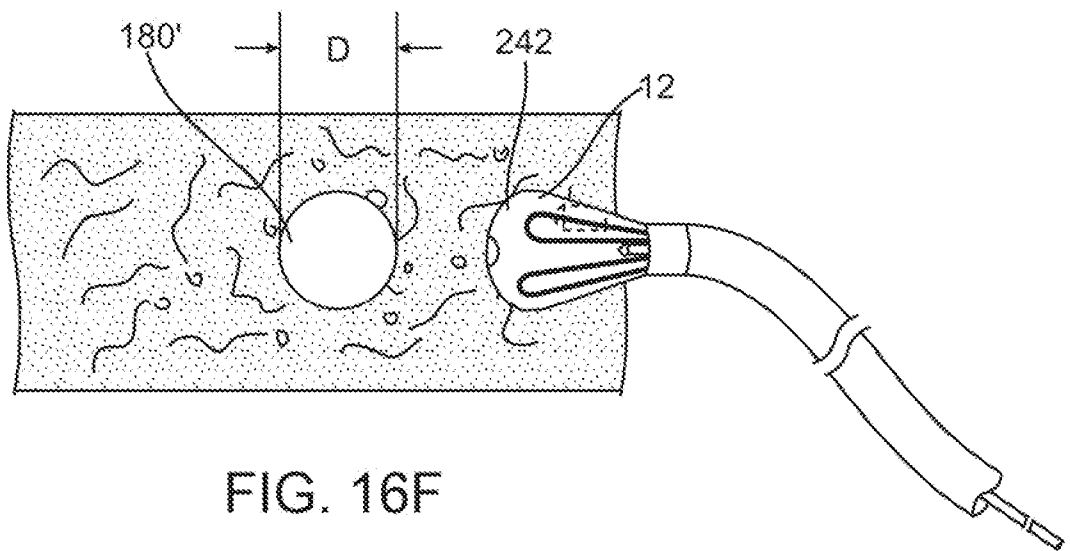

FIG. 16F

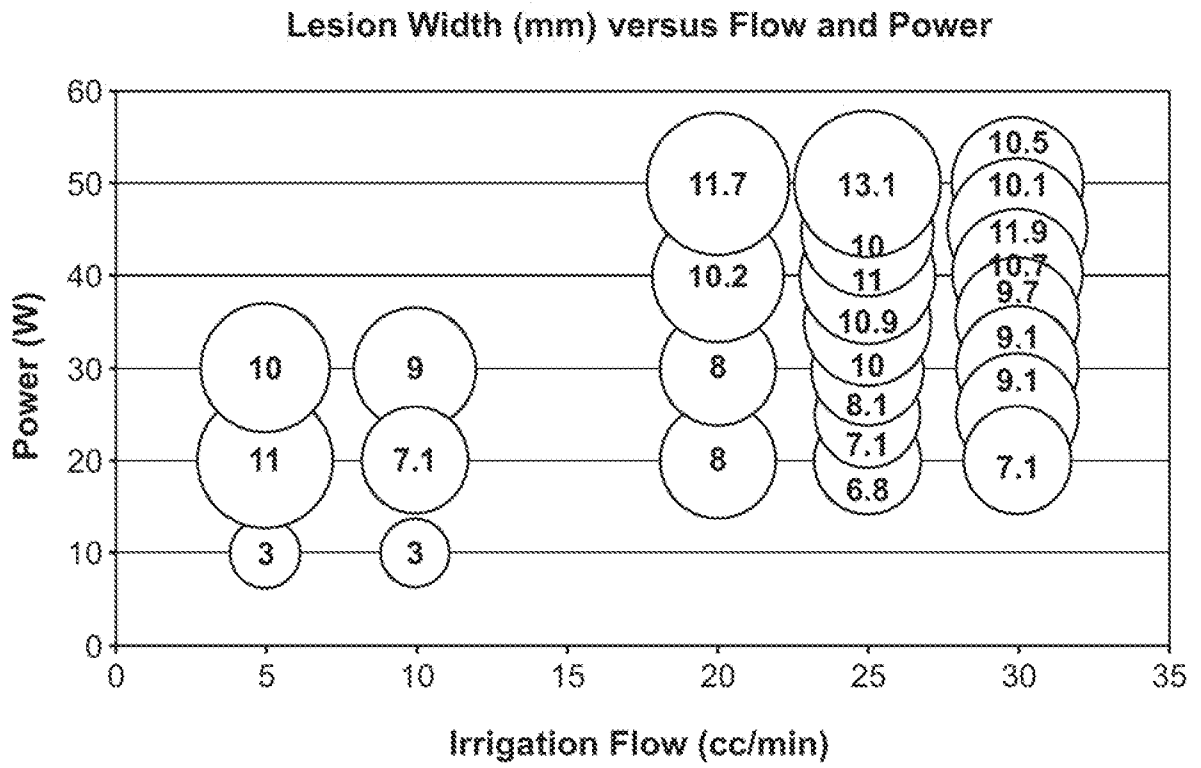

FIG. 17

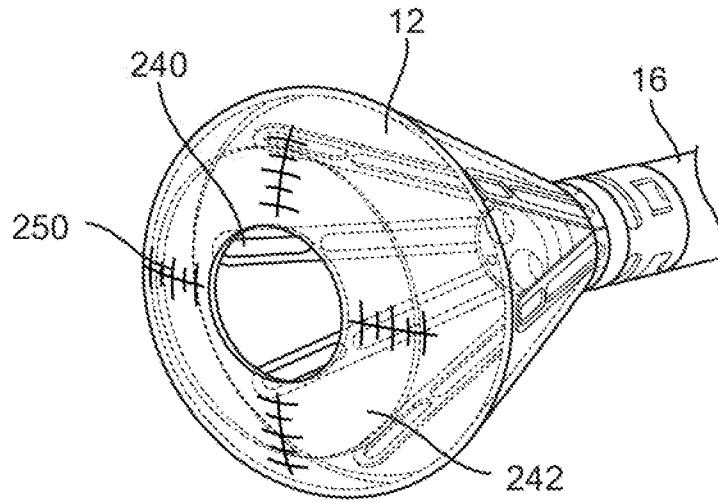

FIG. 18A

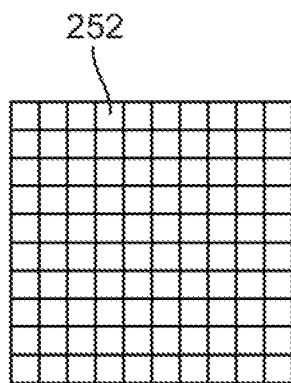

FIG. 18B

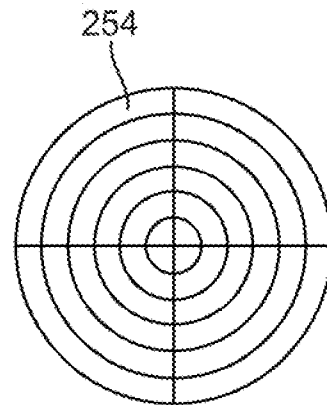

FIG. 18C

27/52

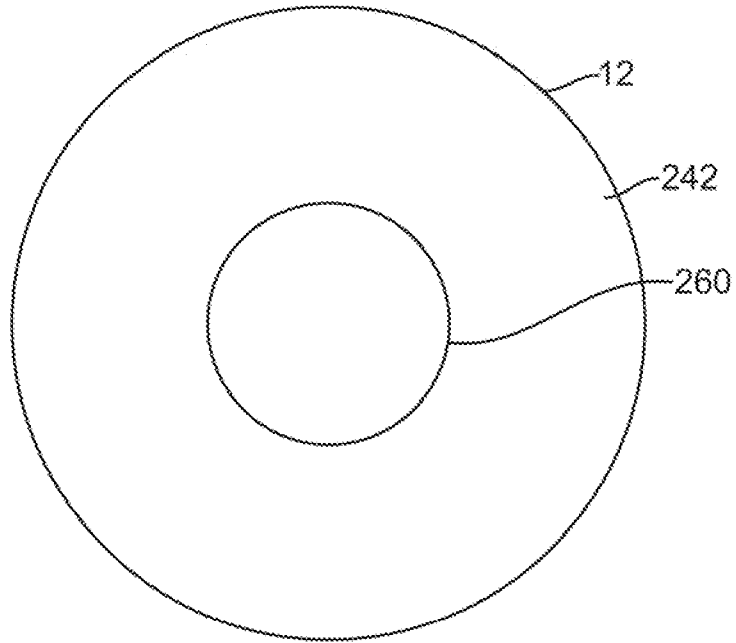

FIG. 19A

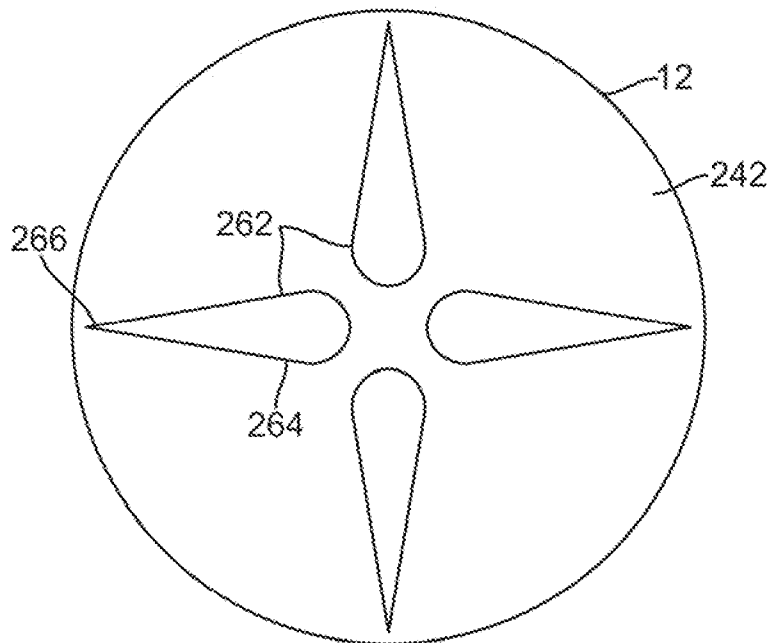

FIG. 19B

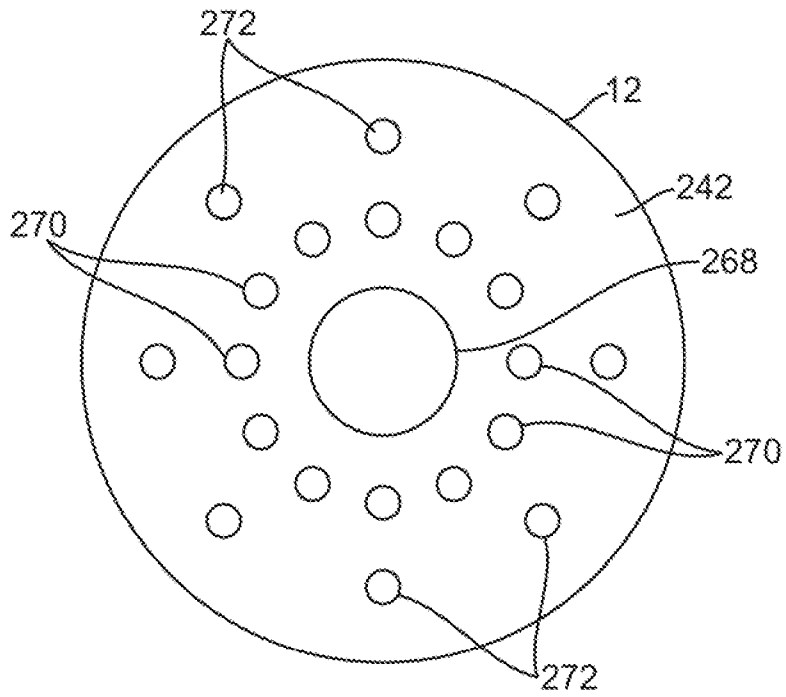

FIG. 19C

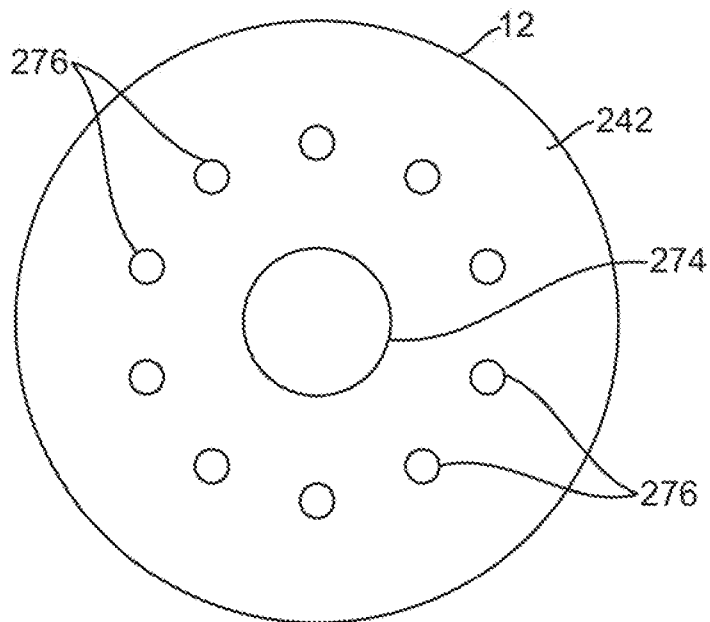

FIG. 19D

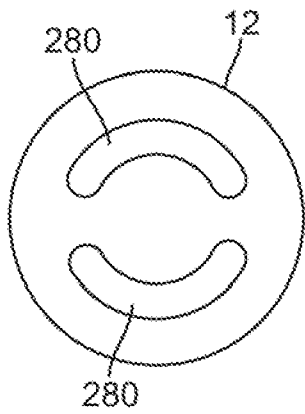

FIG. 20A

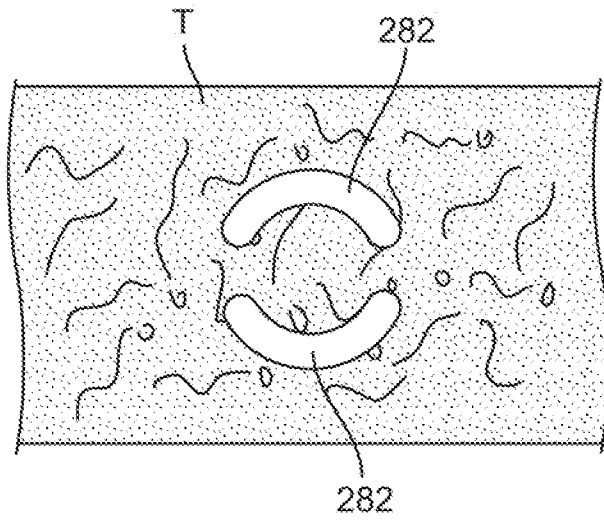

FIG. 20B

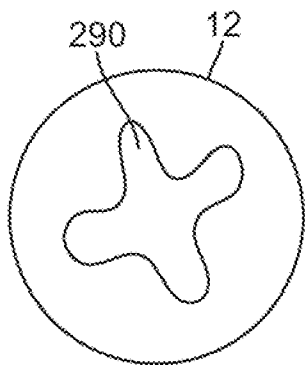

FIG. 21A

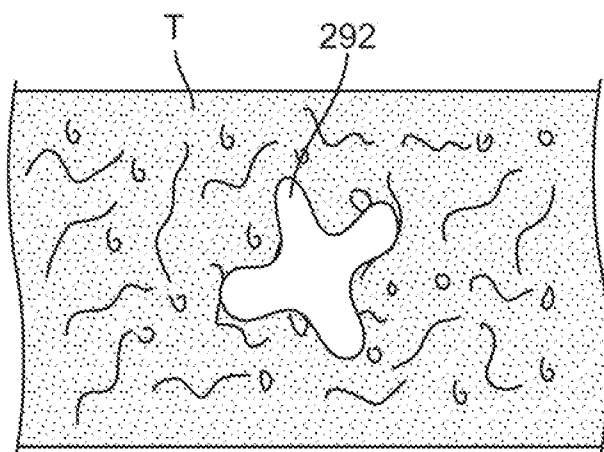

FIG. 21B

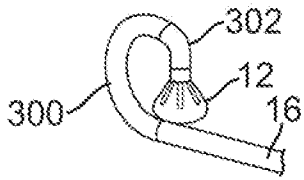

FIG. 22A

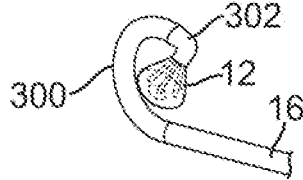

FIG. 22B

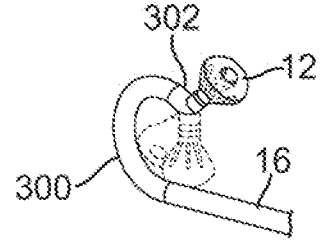

FIG. 22C

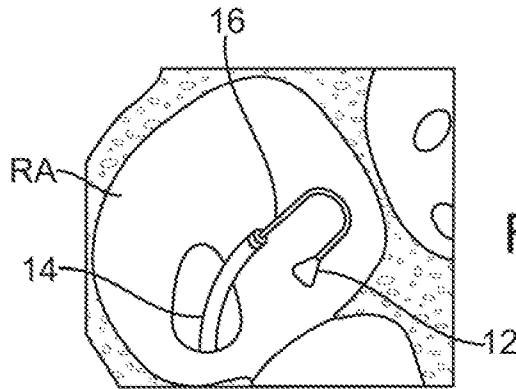

FIG. 23B

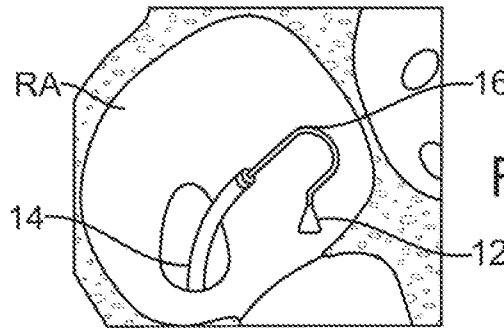

FIG. 23C

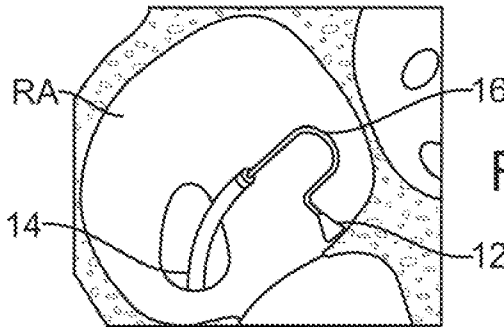

FIG. 23D

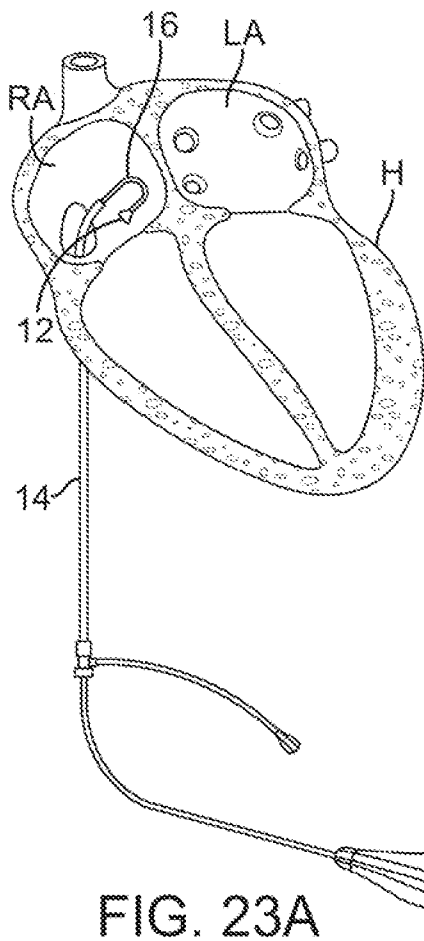

FIG. 23A

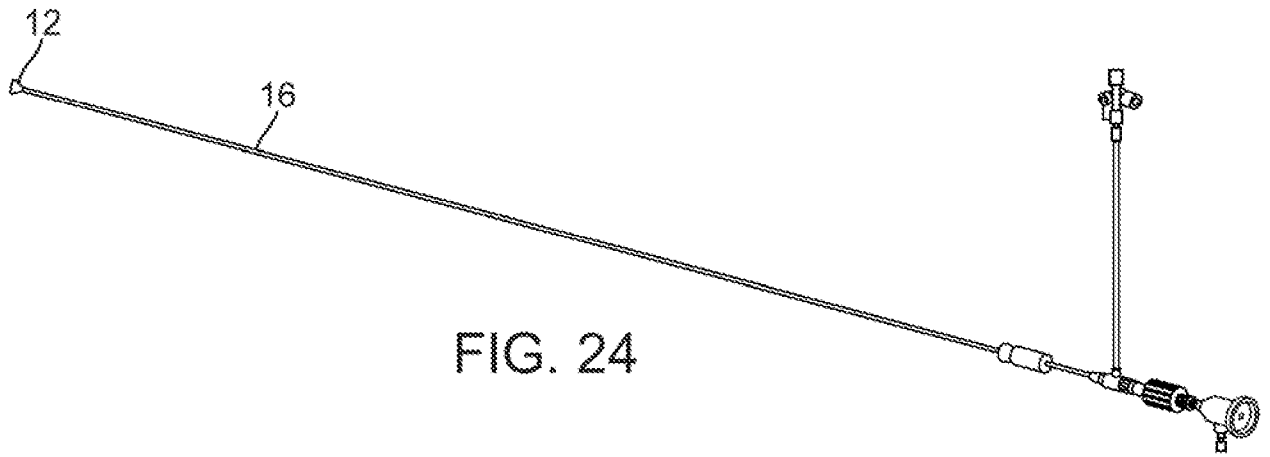

FIG. 24

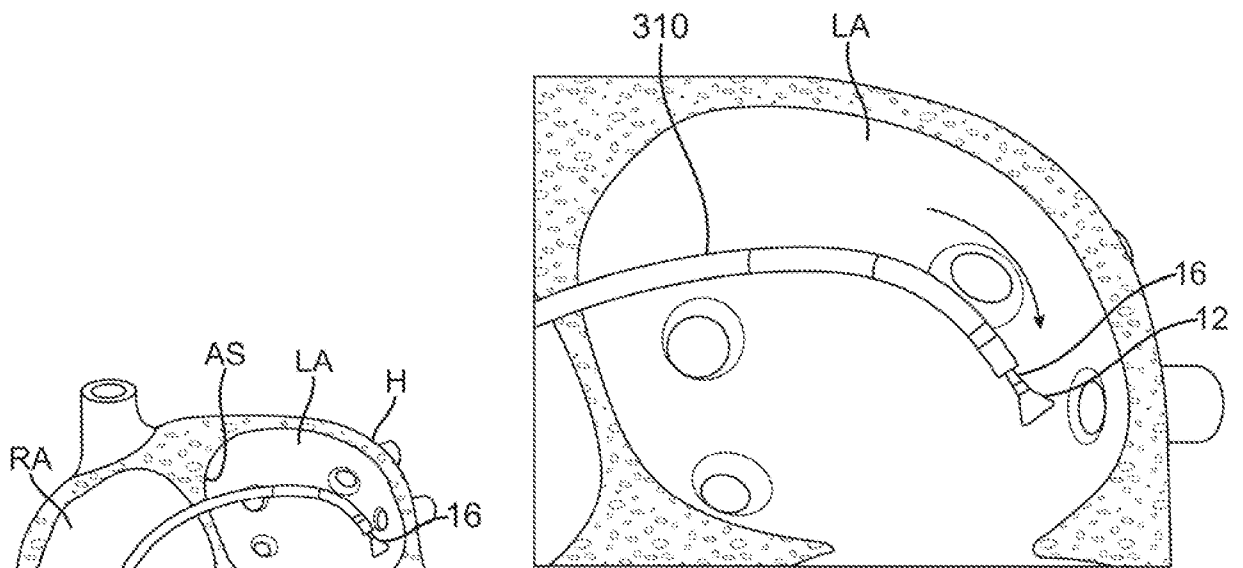

FIG. 25B

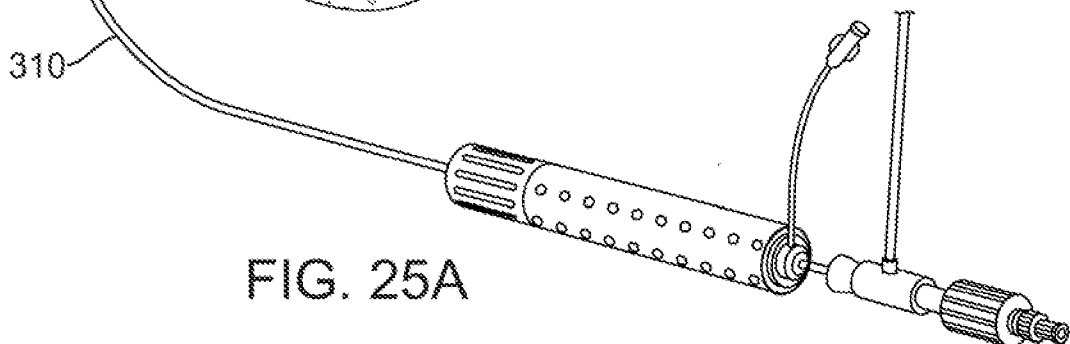

FIG. 25A

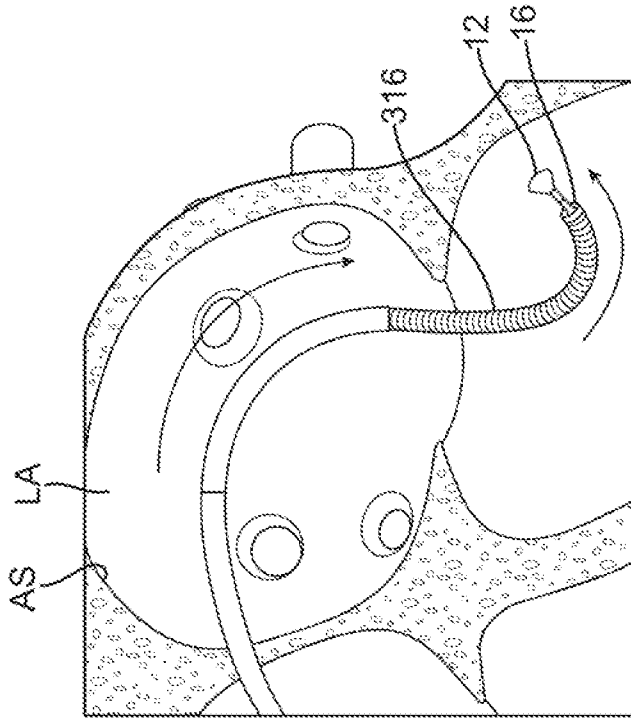
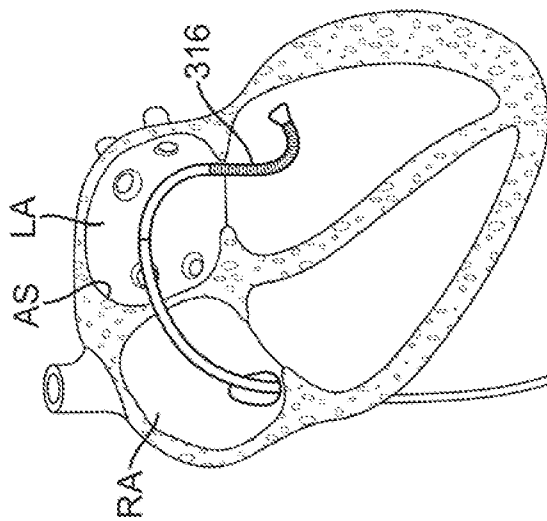

FIG. 26B



312

314

FIG. 26A

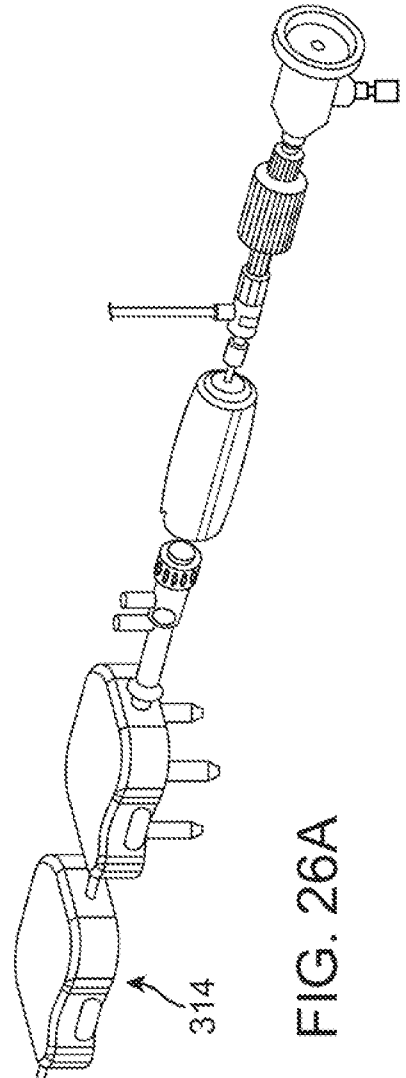

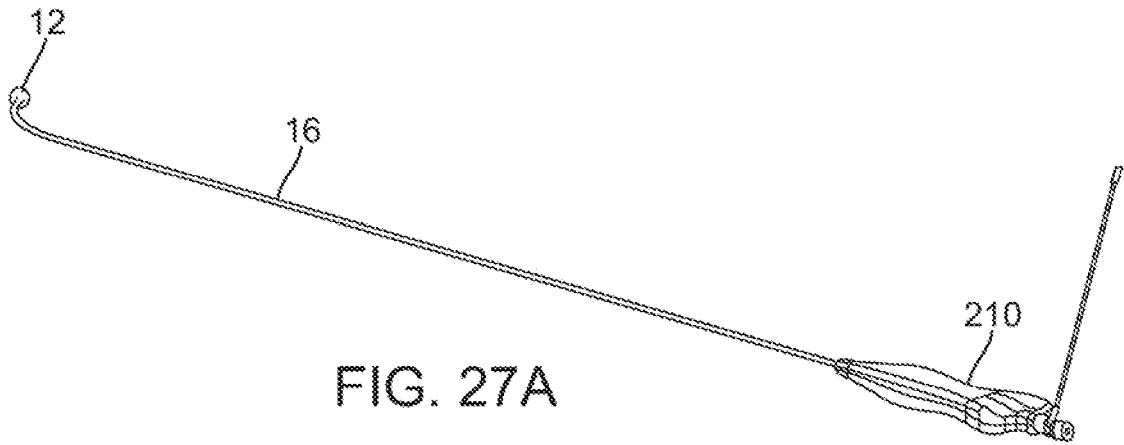

FIG. 27A

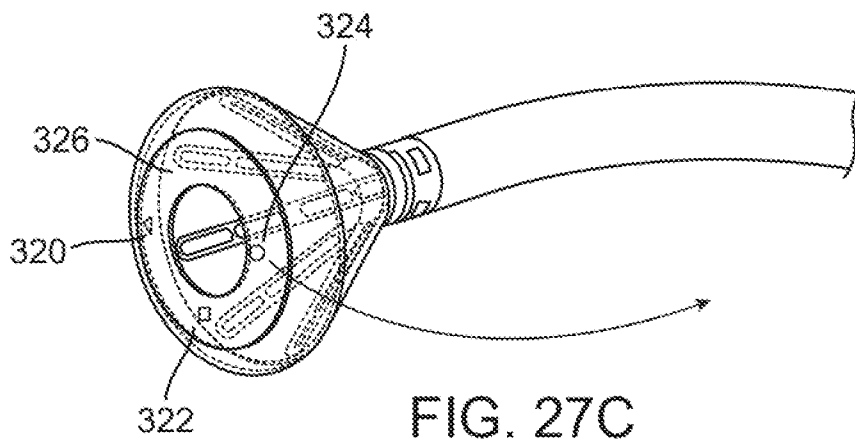

FIG. 27C

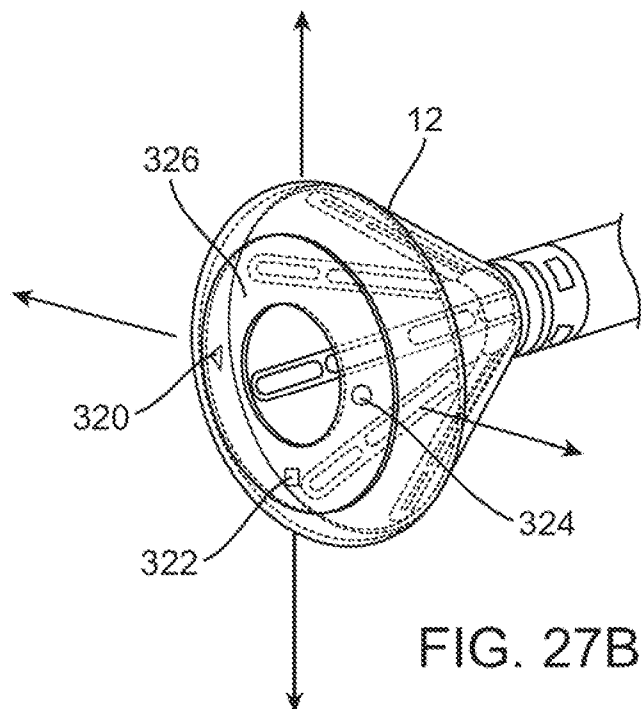

FIG. 27B

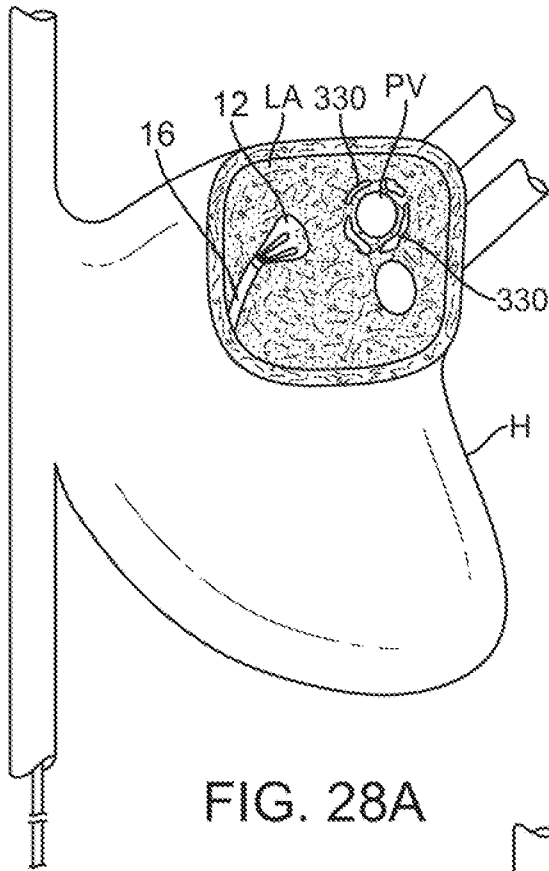

FIG. 28A

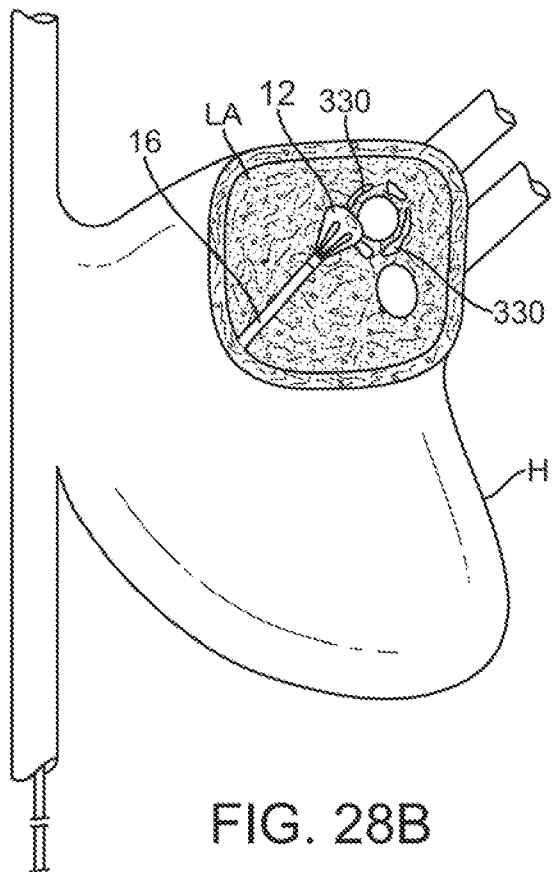

FIG. 28B

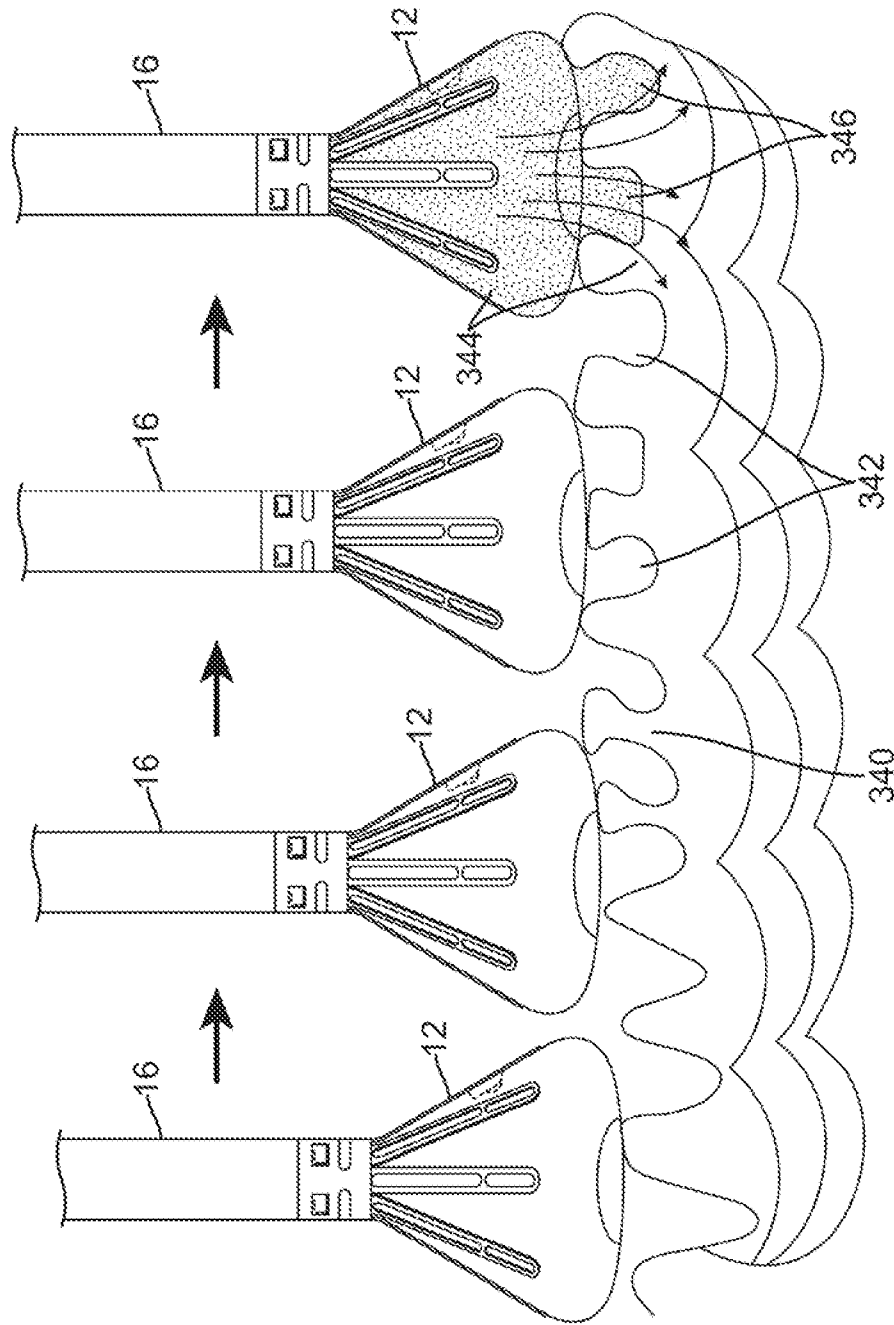

FIG. 29

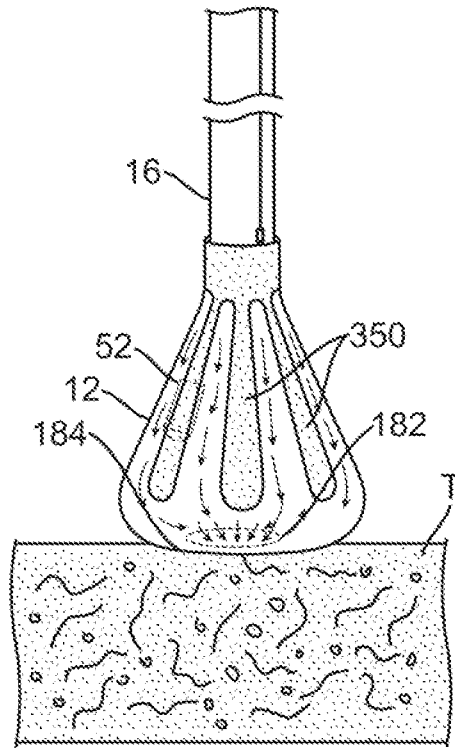

FIG. 30

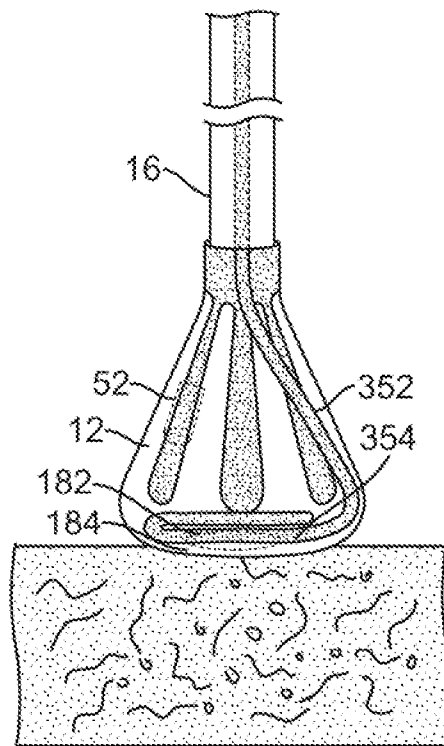

FIG. 31

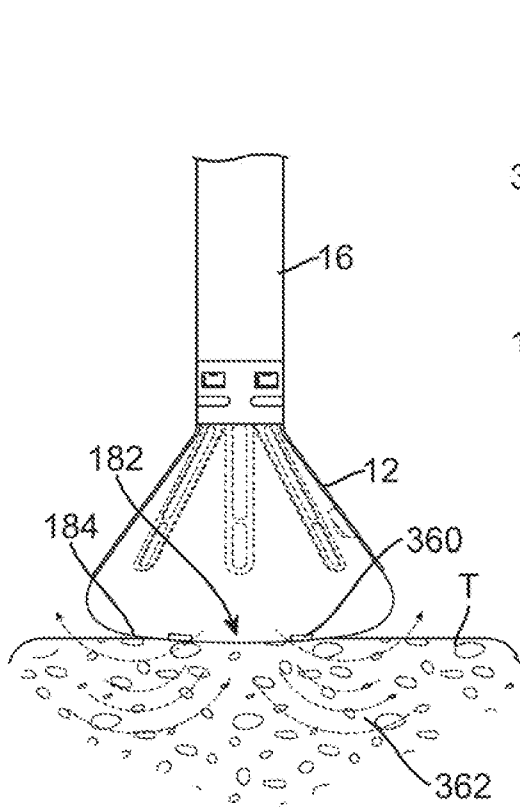

FIG. 32A

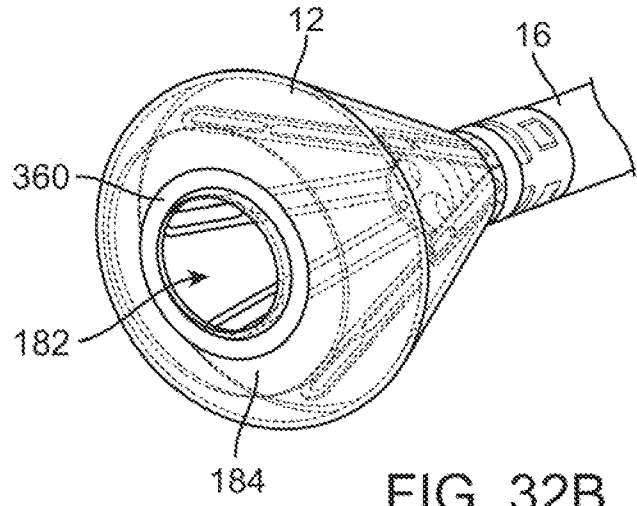

FIG. 32B

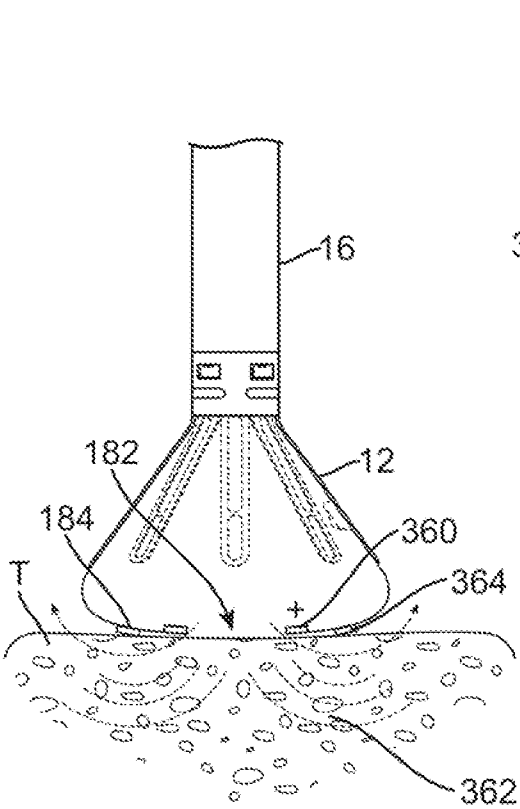

FIG. 33A

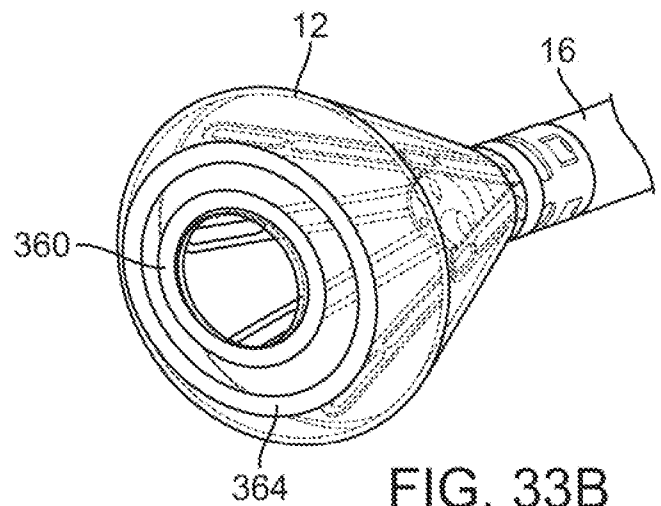

FIG. 33B

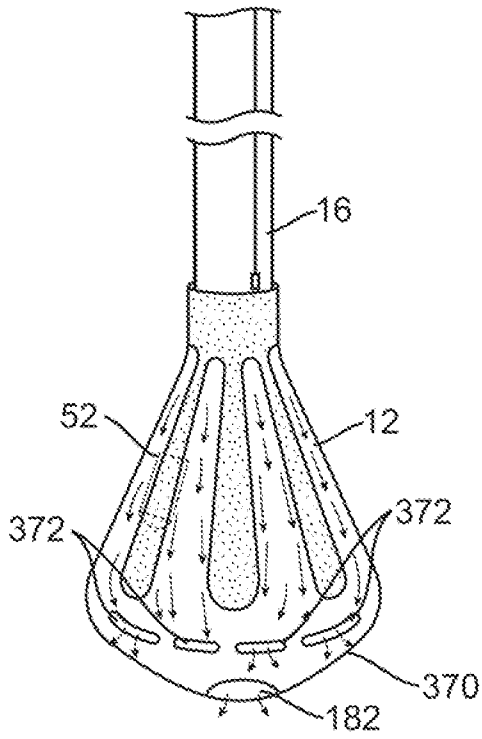

FIG. 34A

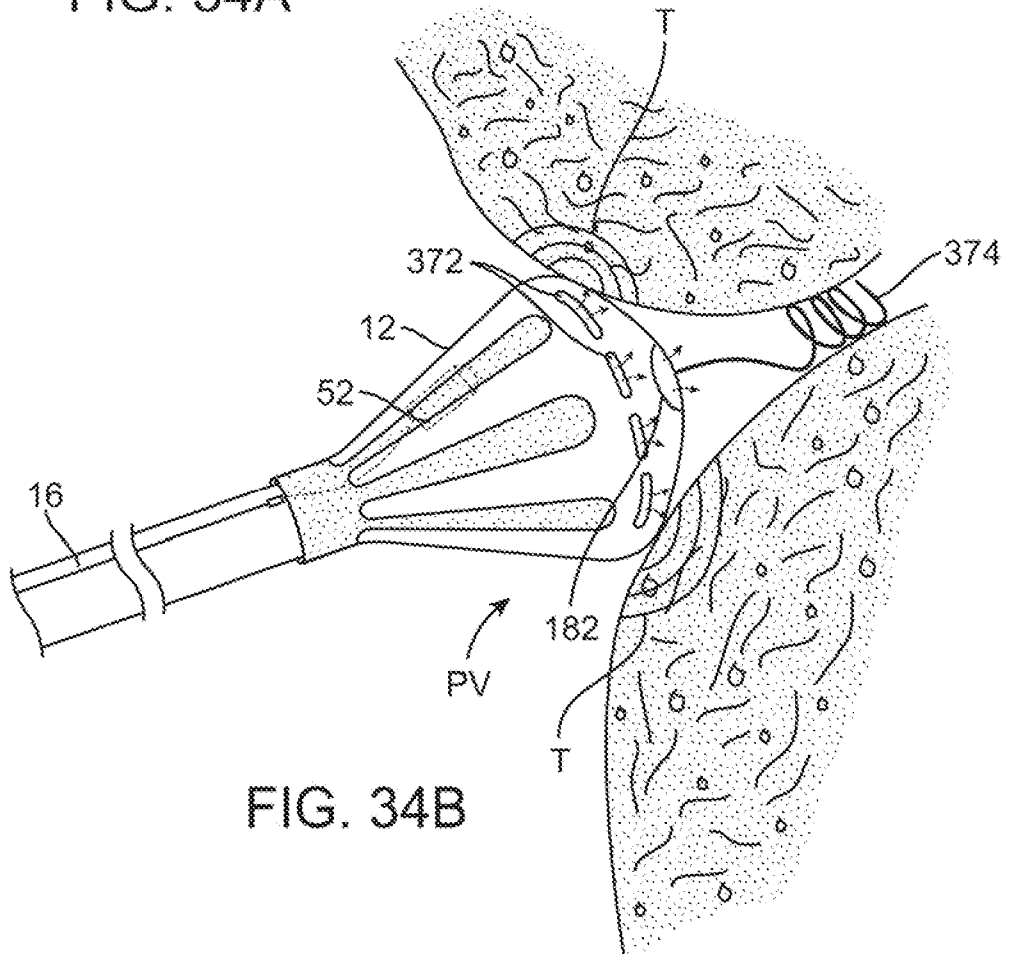

FIG. 34B

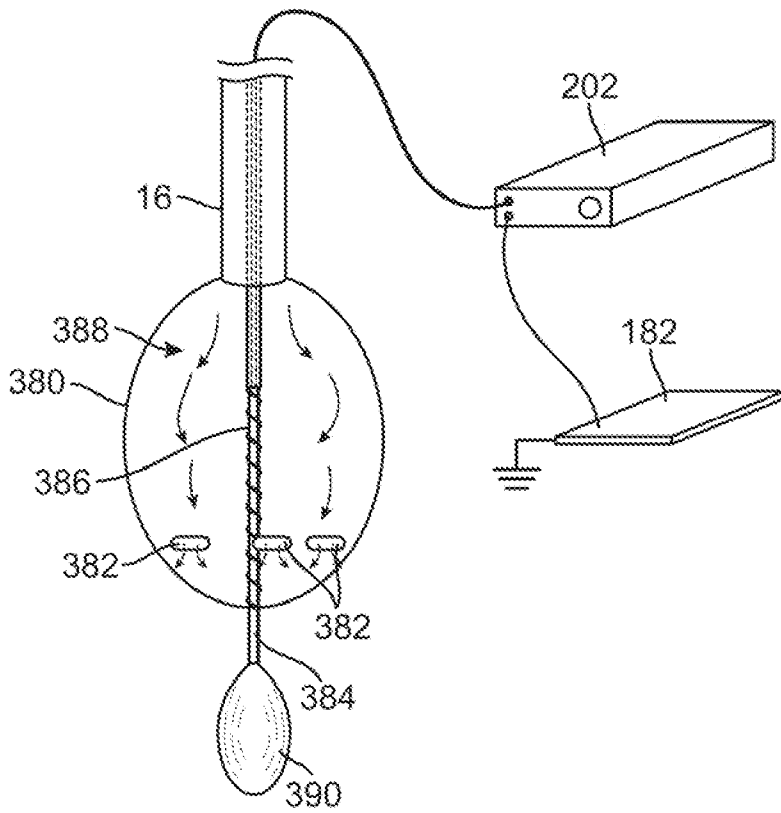

FIG. 35A

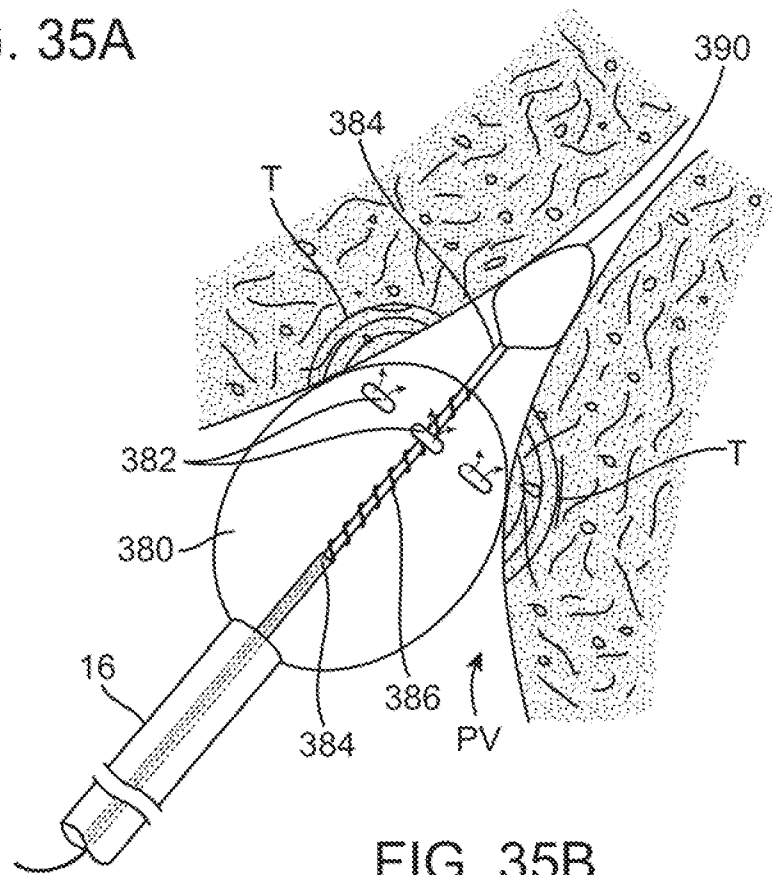
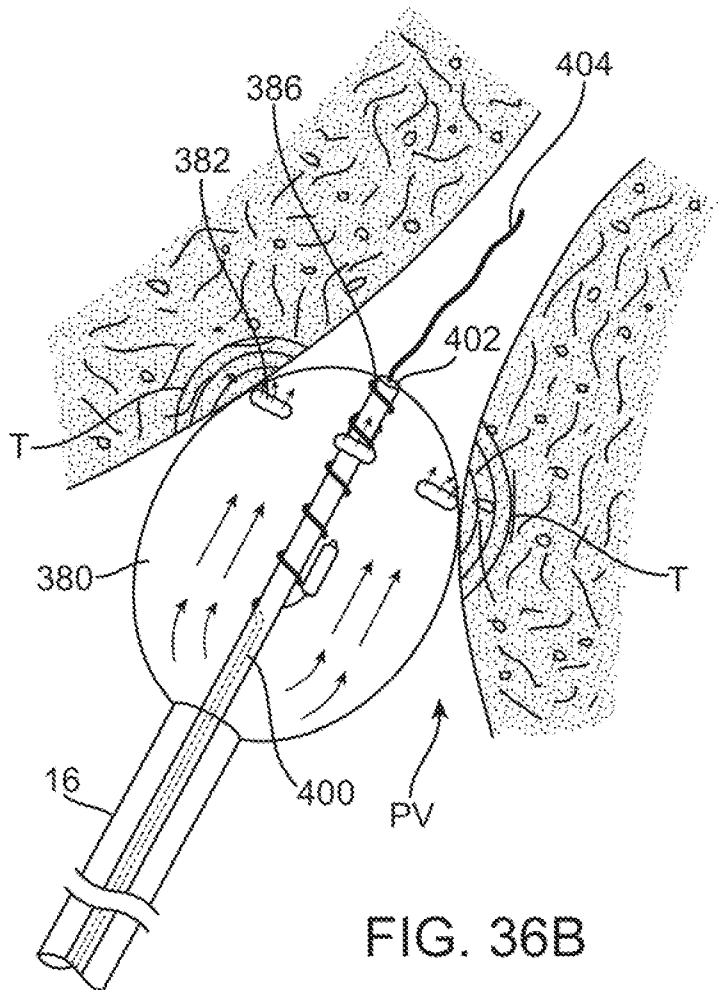
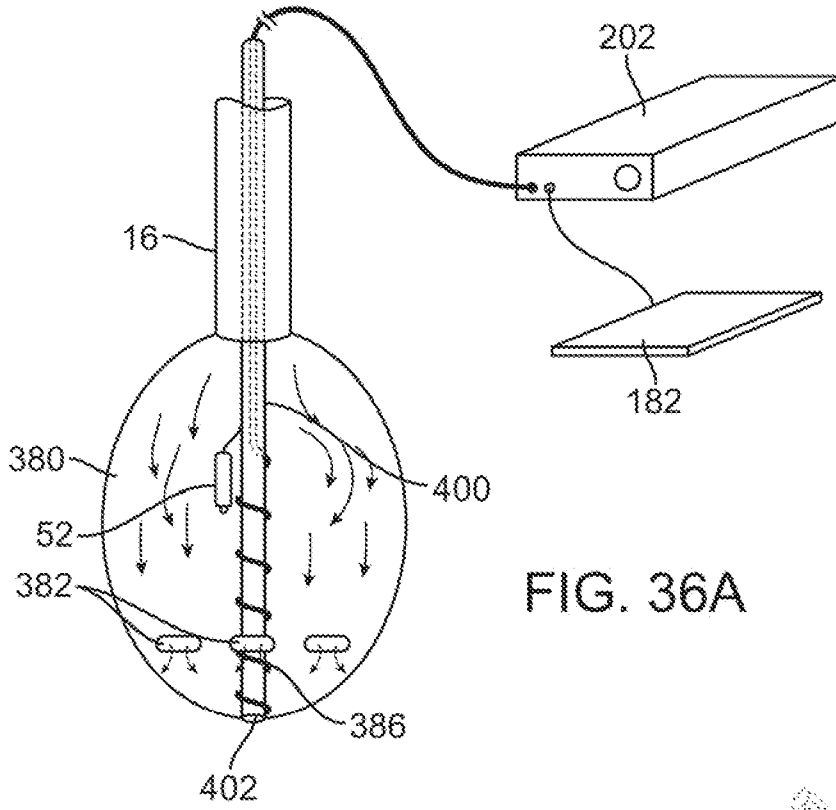

FIG. 35B



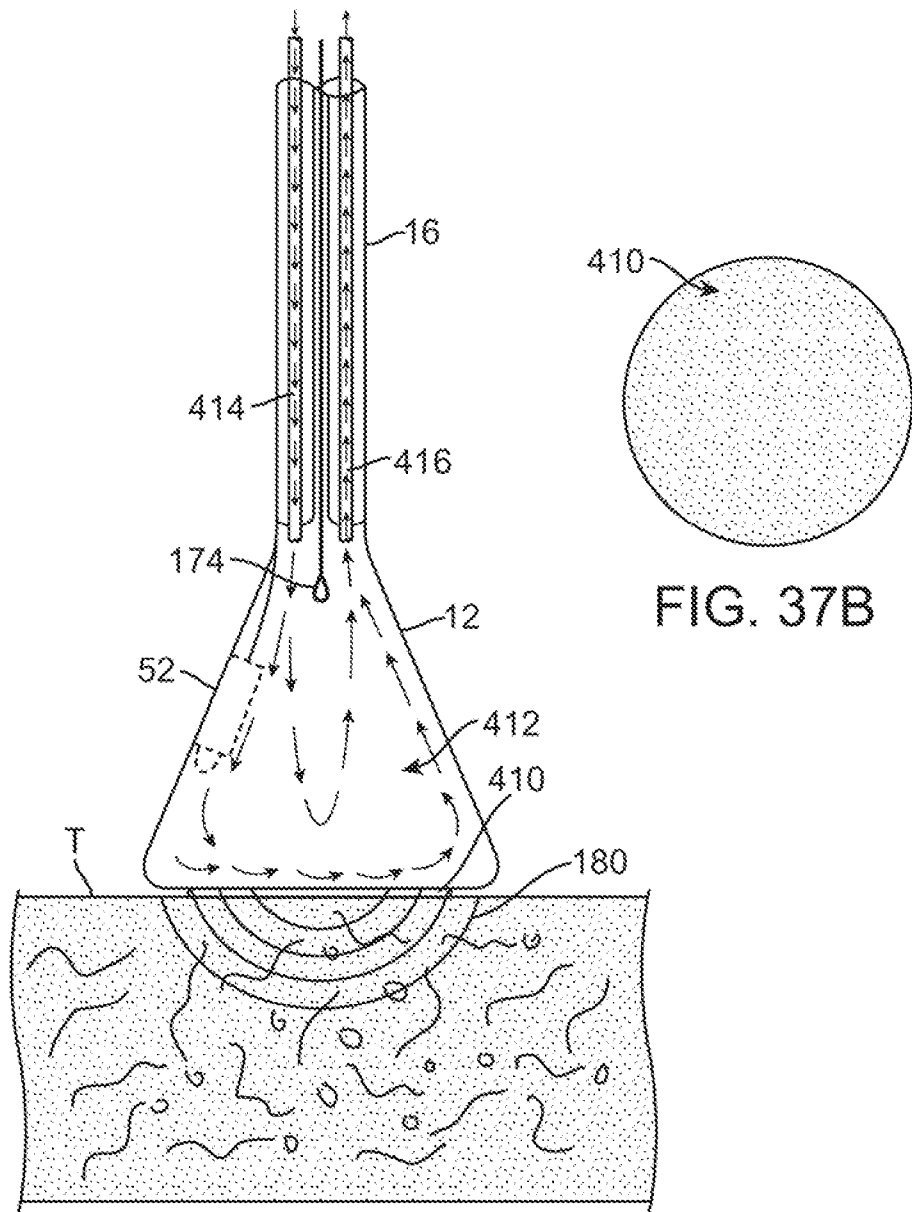

FIG. 37A

FIG. 37B

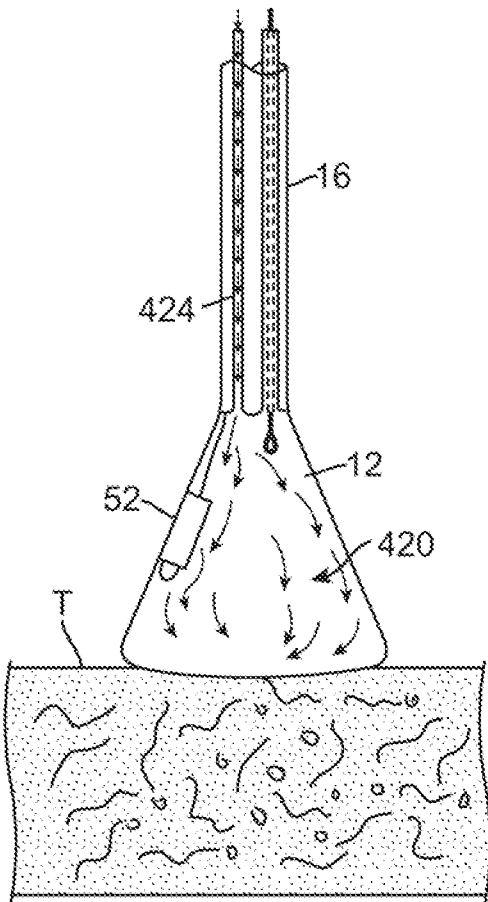

FIG. 38A

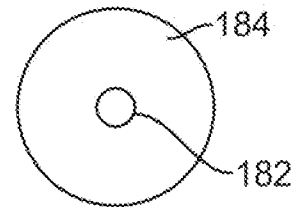

FIG. 38C

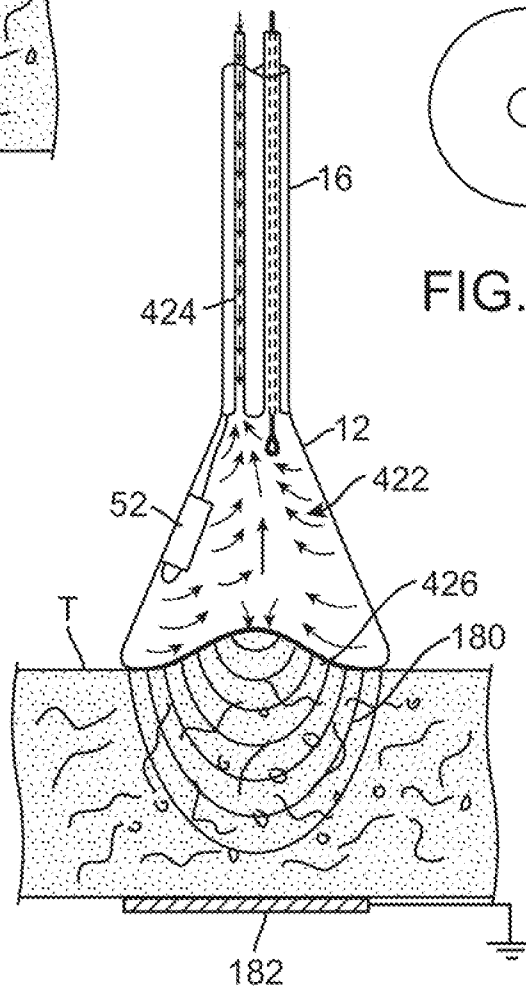

FIG. 38B

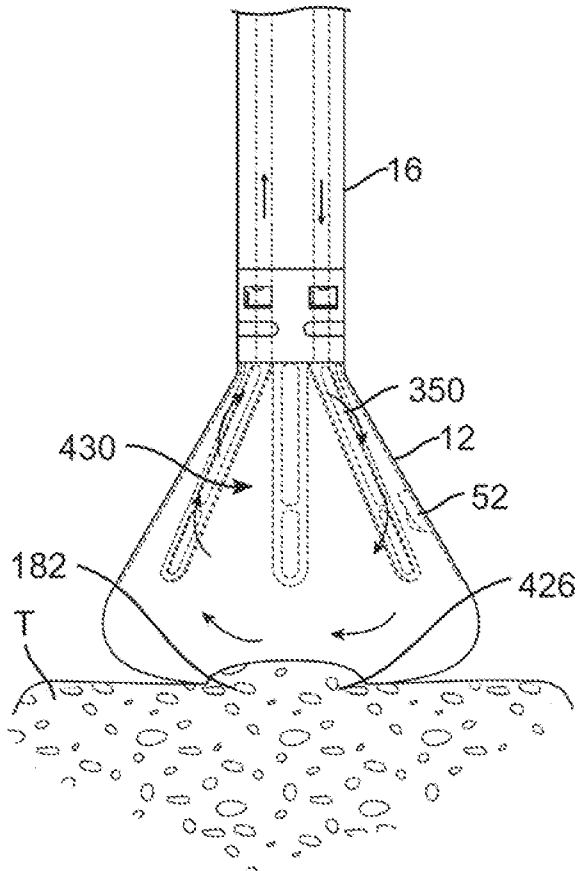

FIG. 39A

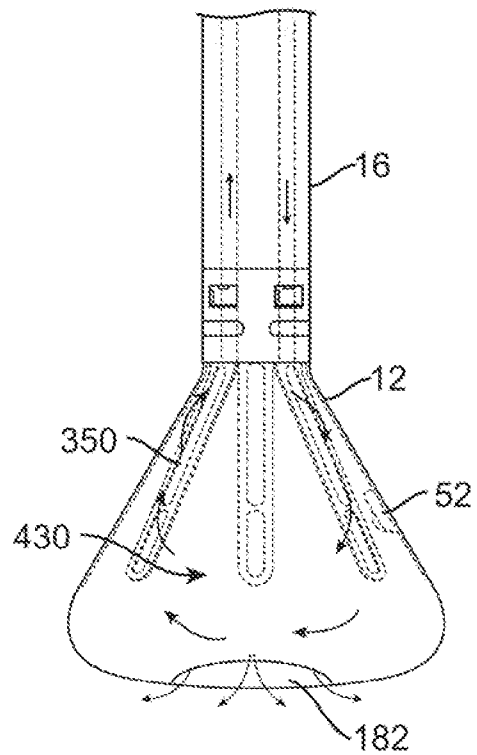

FIG. 39B

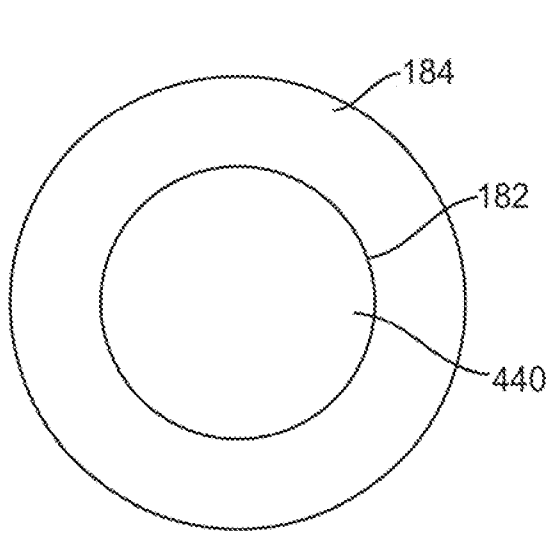

FIG. 40A

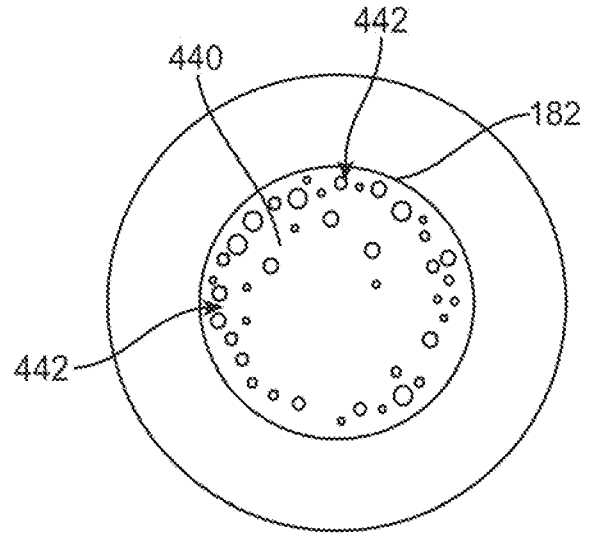

FIG. 40B

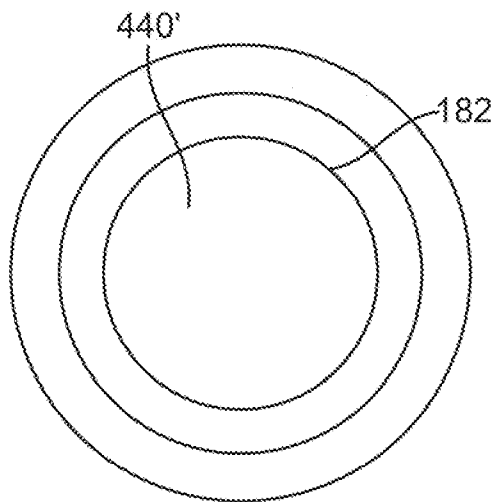

FIG. 40C

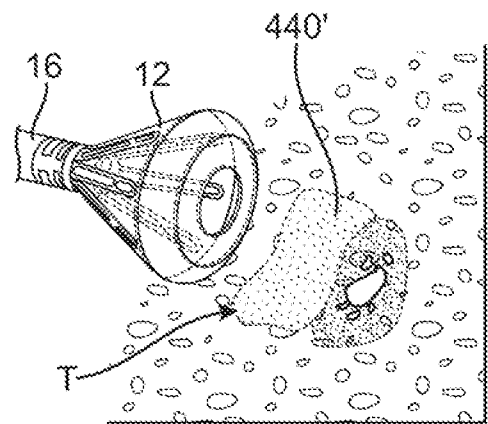

FIG. 40D

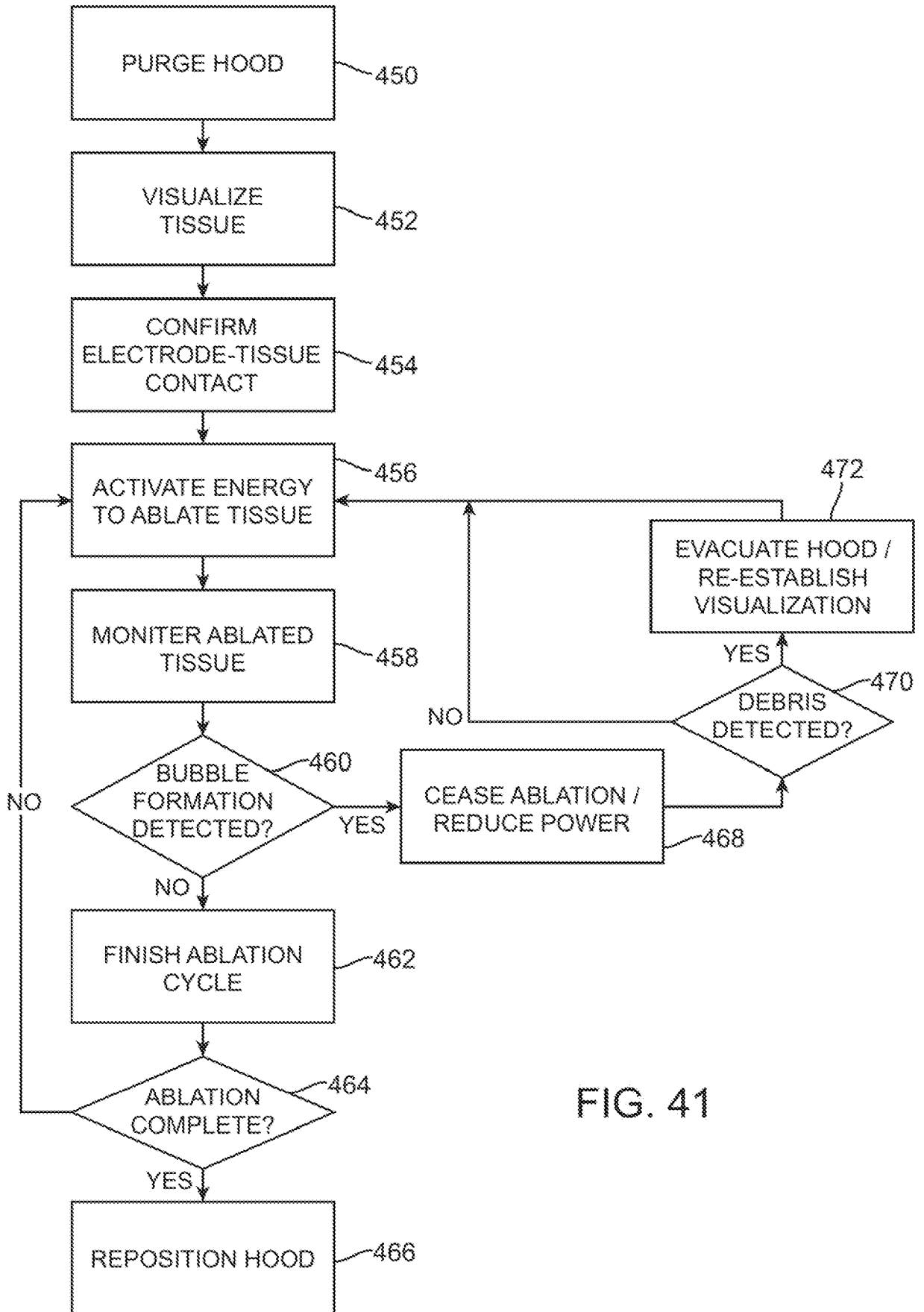

FIG. 41

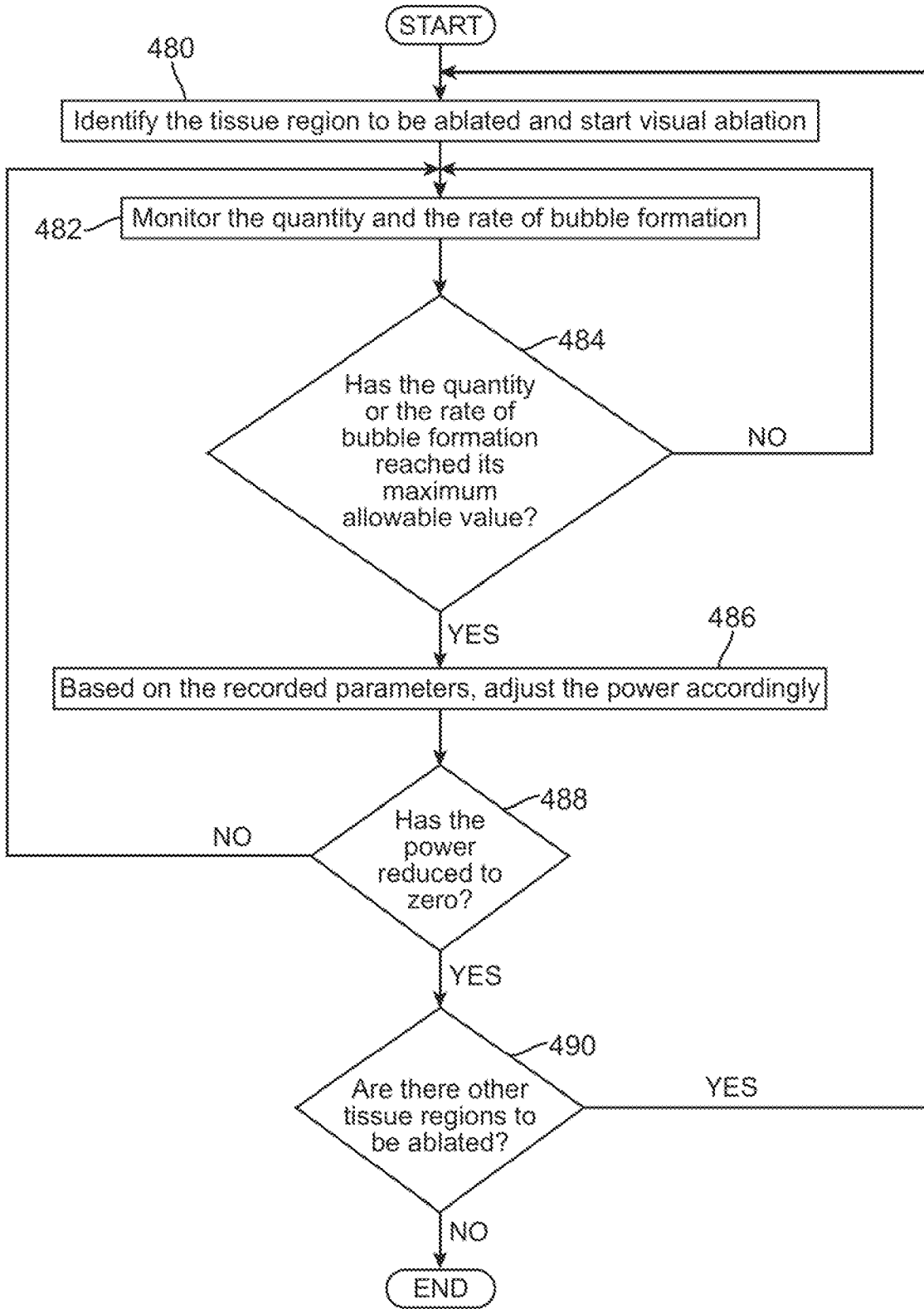

FIG. 42

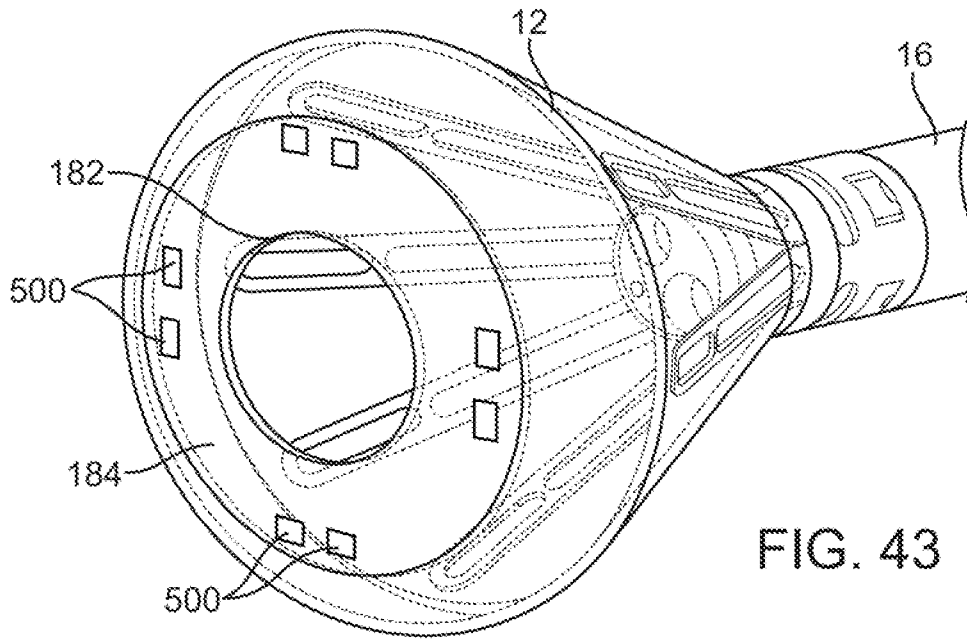

FIG. 43

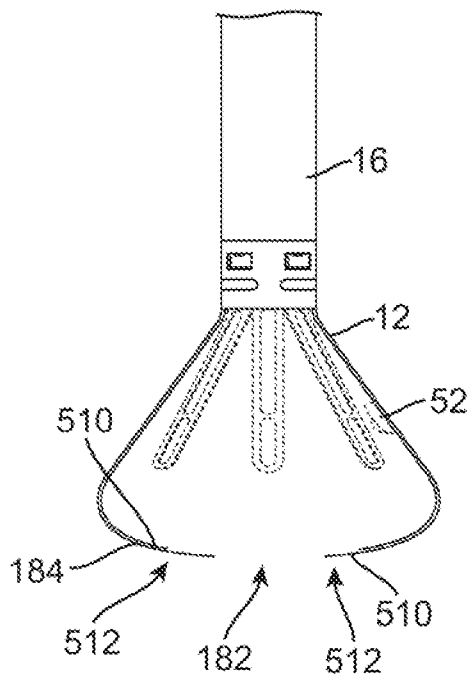

FIG. 44A

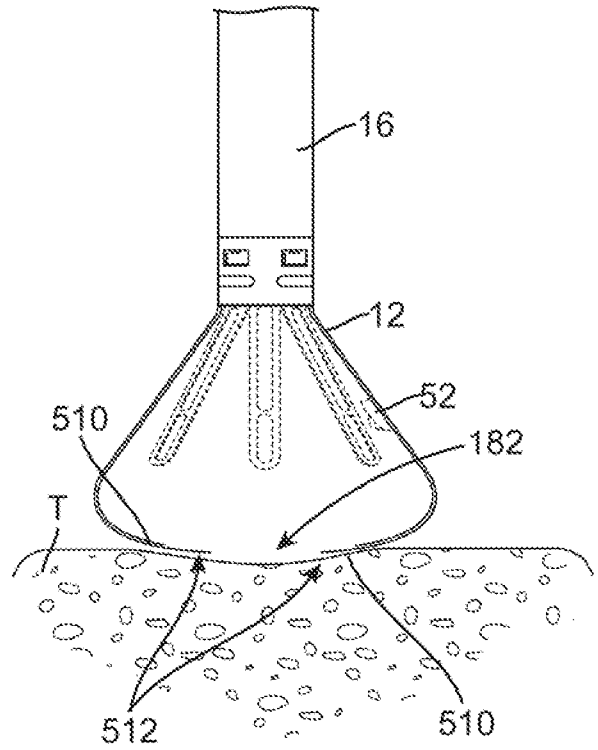

FIG. 44B

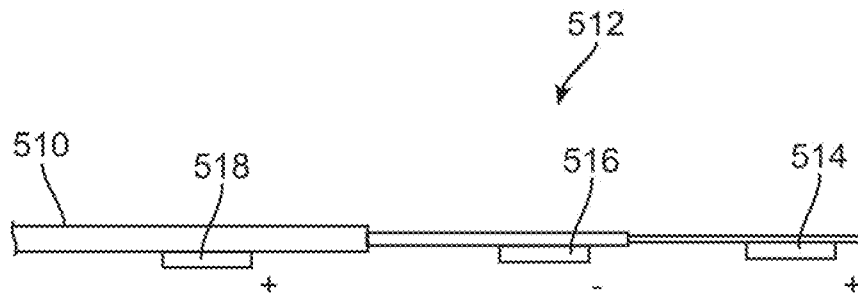

FIG. 44C

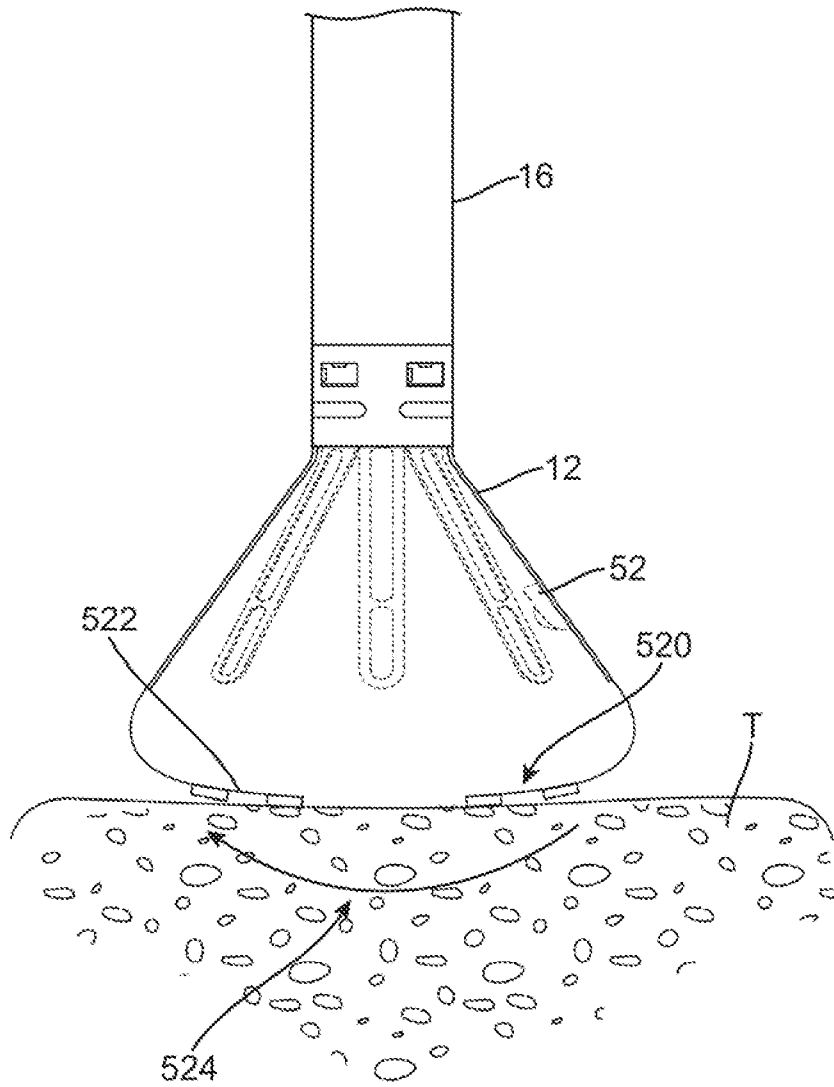

FIG. 45

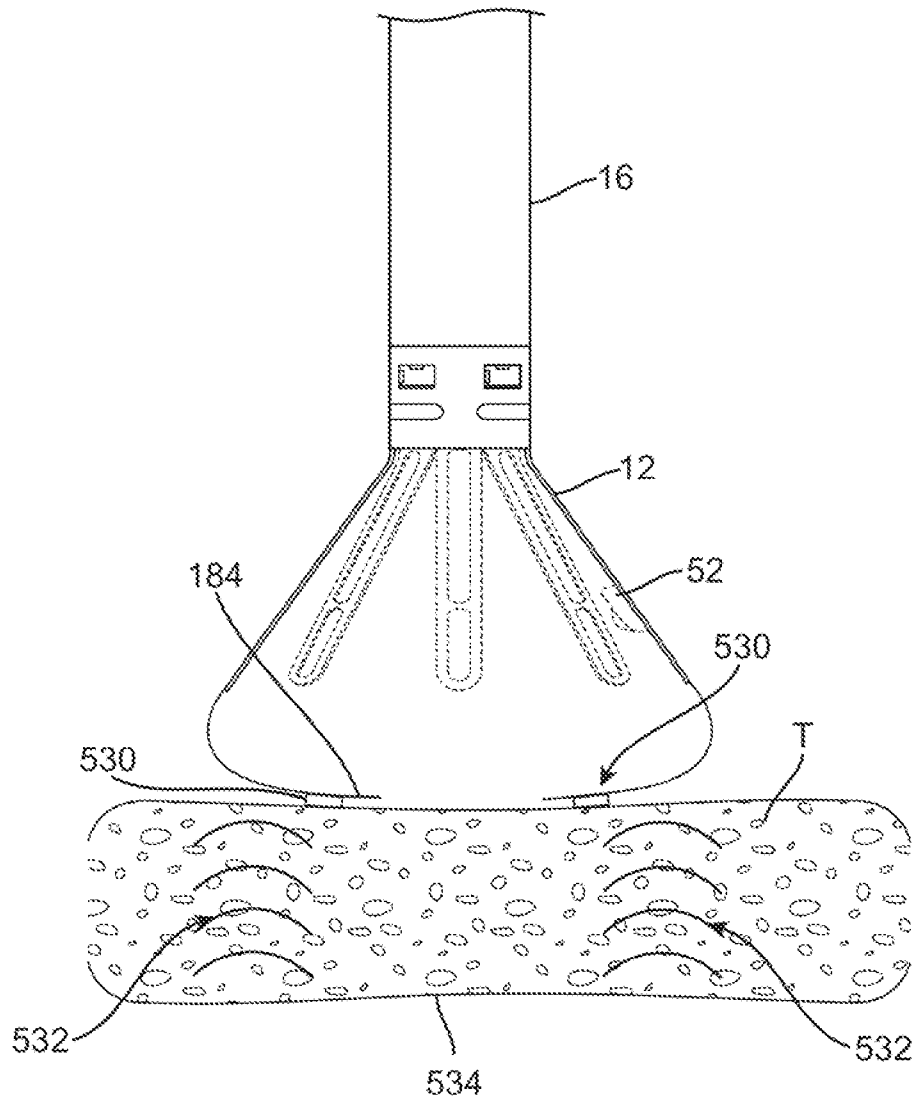

FIG. 46

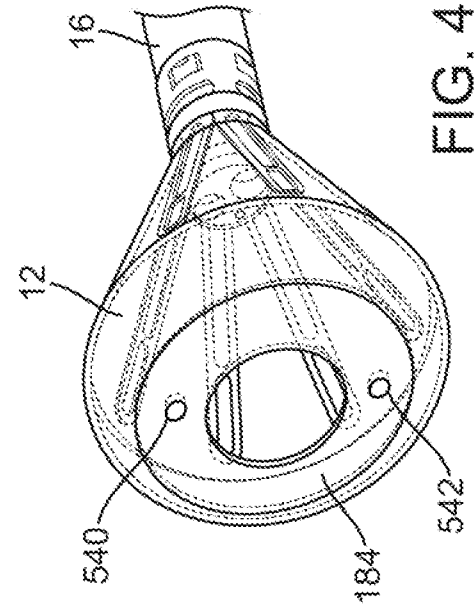

FIG. 47B

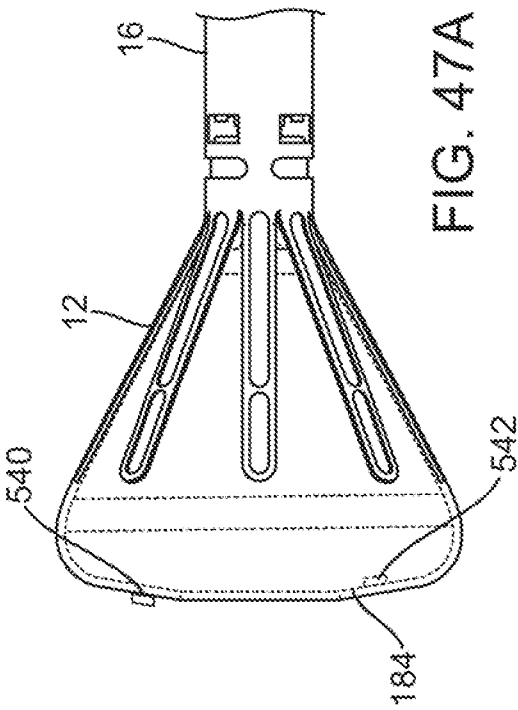

FIG. 47A

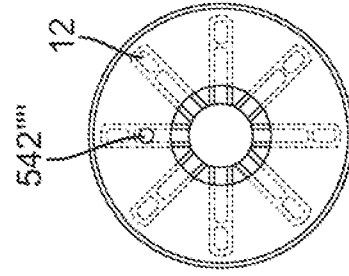

FIG. 48D

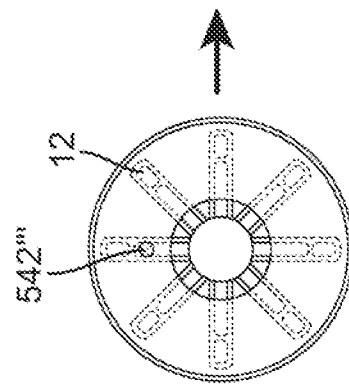

FIG. 48C

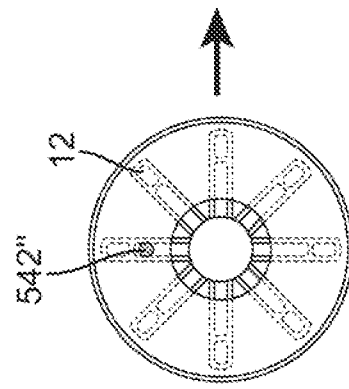

FIG. 48B

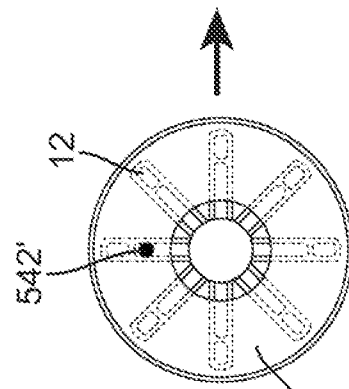

FIG. 48A

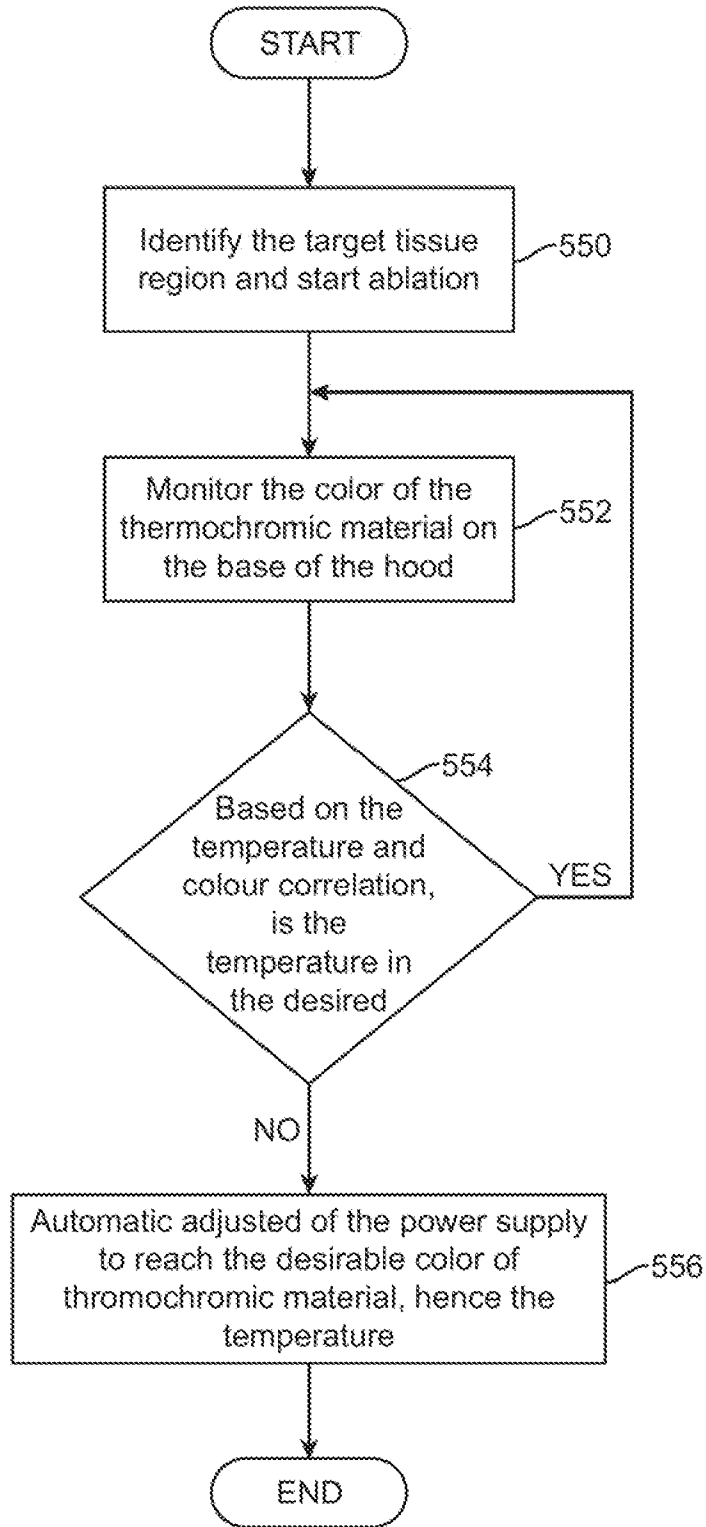

FIG. 49

INTERNATIONAL SEARCH REPORT

International application No.

PCT/US2008/063324

A. CLASSIFICATION OF SUBJECT MATTER
IPC(8) - A61B 1/00,008; A61B1 8/14 (2008.04)

USPC - 600/146,478; 604/95.04; 607/122

According to International Patent Classification (IPC) or to both national classification and IPC

B. FIELDS SEARCHED

Minimum documentation searched (classification system followed by classification symbols)

IPC(8) - A61B 1/00,008; A61B1 8/14 (2008.04)

USPC - 600/146,478; 604/95.04; 607/122

Documentation searched other than minimum documentation to the extent that such documents are included in the fields searched

Electronic data base consulted during the international search (name of data base and, where practicable, search terms used)

USPTO EAST System (US, USPG-PUB, EPO, DERWENT), MicroPatent.

C. DOCUMENTS CONSIDERED TO BE RELEVANT

Category*	Citation of document, with indication, where appropriate, of the relevant passages	Relevant to claim No.
X	US 2006/0184048 A1 (SAADAT) 17 August 2006 (17.08.2006) entire document	1-23,27-29,31-68
--	-----	-----
Y		24-26,30
Y	US 2006/0030844 A1 (KNIGHT et al) 09 February 2006 (09.02.2006) entire document	24-26,30

 Further documents are listed in the continuation of Box C.

* Special categories of cited documents:

"A" document defining the general state of the art which is not considered to be of particular relevance

"E" earlier application or patent but published on or after the international filing date

"L" document which may throw doubts on priority claim(s) or which is cited to establish the publication date of another citation or other special reason (as specified)

"O" document referring to an oral disclosure, use, exhibition or other means

"P" document published prior to the international filing date but later than the priority date claimed

"T" later document published after the international filing date or priority date and not in conflict with the application but cited to understand the principle or theory underlying the invention

"X" document of particular relevance; the claimed invention cannot be considered novel or cannot be considered to involve an inventive step when the document is taken alone

"Y" document of particular relevance; the claimed invention cannot be considered to involve an inventive step when the document is combined with one or more other such documents, such combination being obvious to a person skilled in the art

"&" document member of the same patent family

Date of the actual completion of the international search

12 September 2008

Date of mailing of the international search report

22 SEP 2008

Name and mailing address of the ISA/US

Mail Stop PCT, Attn: ISA/US, Commissioner for Patents

P.O. Box 1450, Alexandria, Virginia 22313-1450

Facsimile No. 571-273-3201

Authorized officer.

Blaine R. Copenheaver

PCT Helpdesk: 571-272-4300
PCT OSP: 571-272-7774