

(19)



(11)

EP 2 733 247 B1

(12)

EUROPEAN PATENT SPECIFICATION

(45) Date of publication and mention of the grant of the patent:
21.12.2016 Bulletin 2016/51

(51) Int Cl.:
D06F 35/00 (2006.01)

(21) Application number: **13193069.5**

(22) Date of filing: **15.11.2013**

(54) Linen washing machine and relative operating method

Wäschewaschmaschine und zugehöriges Betriebsverfahren

Machine à laver le linge et procédé de fonctionnement associé

(84) Designated Contracting States:
AL AT BE BG CH CY CZ DE DK EE ES FI FR GB GR HR HU IE IS IT LI LT LU LV MC MK MT NL NO PL PT RO RS SE SI SK SM TR

- **Dottori, Mariangiola**
60043 Cerreto d'Esi (AN) (IT)
- **Latini, Giuliana**
60044 Fabriano (AN) (IT)

(30) Priority: **19.11.2012 IT PR20120077**

(74) Representative: **Guerci, Alessandro et al**
Whirlpool Europe S.r.l.
Patent Department
Viale G. Borghi 27
21025 Comerio (VA) (IT)

(43) Date of publication of application:
21.05.2014 Bulletin 2014/21

(73) Proprietor: **Indesit Company S.p.A.**
60044 Fabriano (AN) (IT)

(56) References cited:
EP-A1- 1 281 803 EP-A1- 2 487 288
US-A1- 2008 189 875

(72) Inventors:
• **Mancini, Mauro**
60044 Fabriano (AN) (IT)

EP 2 733 247 B1

Note: Within nine months of the publication of the mention of the grant of the European patent in the European Patent Bulletin, any person may give notice to the European Patent Office of opposition to that patent, in accordance with the Implementing Regulations. Notice of opposition shall not be deemed to have been filed until the opposition fee has been paid. (Art. 99(1) European Patent Convention).

Description

[0001] The present invention relates to a linen washing machine and an operating method of a linen washing machine.

[0002] Washing machines of the prior art envisage a step of washing linen and a subsequent step of rinsing it.

[0003] In particular, washing machines are known wherein the quantity of water to be used during the rinse step is a function of the values rigidly pre-set in the electronic board. In order to avoid wasting water in some of such washing machines the user, by activating a relevant button, can select the half load function. In that case the user can at his discretion decide that the load of linen is moderate and can therefore request a lower quantity of water during the rinse. The half load function is usually associated with a reduction in water consumption and therefore electrical energy also during the actual washing step and not only during the rinse.

[0004] However, this solution is not free from drawbacks. In fact, the choice that the user makes based on his own sensitivity is not always the optimal one.

[0005] The user often bases his choice on the mass of linen to be washed and not on the degree of water absorption that such linen can offer. For example, the user could decide to use the half load program when he needs to wash products which, whilst having a reduced mass, actually absorb a large quantity of water (which could translate into an insufficient rinse).

[0006] Document US 2008/189875 A1 discloses a wetting process in a washing machine entailing driving the drum continuously in a second phase until the water level in the tub reaches the level determined by the drop recognized in a first phase. Document EP 1281803 A1 discloses a control method for a washing machine including the step of selecting one of a plurality of different rinsing and/or spin-drying cycles depending on the absorbency of the laundry being washed.

[0007] In this context, the technical task underpinning the present invention is to provide a washing machine and method that enables the linen rinse parameters to be optimised, in particular the quantity of water required in such an operation.

[0008] The technical task set and the objects specified are substantially attained by a washing machine and method, comprising the technical characteristics as set out in one or more of the accompanying claims.

[0009] Further characteristics and advantages of the present invention will appear more clearly from the indicative and non-limiting description of a preferred, but not exclusive, embodiment of a washing machine, as shown in Figure 1.

[0010] In the accompanying drawing, number 1 indicates a linen washing machine. This machine is typically a washing machine, but could also be a washer-dryer.

[0011] As shown by way of example in Figure 1, the washing machine 1 comprises a washing compartment 2. Typically the washing machine 1 comprises a linen

housing drum 3 that can rotate and that is placed inside the washing compartment 2.

[0012] The washing machine 1 further comprises a washing liquid level sensor 4 in said compartment 2.

5 **[0013]** The level sensor 4 is able to identify a first operating condition in which the measured level is higher than a first predefined level L1 and a second operating condition in which the measured level is lower than a second predefined level L2 (the second level L2 is lower than the first level L1).

10 **[0014]** On this point, the level sensor 4 is usually a pressure switch. For example, the pressure switch could be a differential pressure switch. In this case, in the first operating condition, the pressure switch assumes a first configuration whereas in the second operating condition the pressure switch assumes a second configuration which is physically different from the first configuration. In an alternative embodiment, the pressure switch may also be a linear pressure switch which detects in steps the level variations in the compartment 2. The differential pressure switch, unlike the linear pressure switch, is only able to determine whether a discrete number of pressure thresholds is exceeded or not (usually one or two).

20 **[0015]** As shown by way of example in Figure 1, the pressure switch is placed along a line 90 for unloading the washing liquid from the compartment 2.

25 **[0016]** Appropriately the washing machine 1 comprises washing liquid introduction means 6 into the compartment 2. The washing liquid introduction means 6 are operatively associated with the level sensor 4 and in the first and second operating condition they respectively stop and activate the introduction of washing liquid into the compartment 2. For example, the introduction means 6 comprise a solenoid valve 5 that is closed in the first operating condition, whereas it is open in the second operating condition.

30 **[0017]** As will be described more fully below, during a washing liquid loading step a quantity of liquid is initially loaded in order to reach said first predefined level L1. This first predefined level L1 is higher with respect to a lower portion 30 of the housing drum 3. Consequently the linen will absorb part of the washing liquid determining a lowering of the level of liquid in the compartment 2.

35 **[0018]** If the level in the compartment 2 drops below the value L2, the reduction in the level will be compensated for by introducing a new quantity of washing liquid (through the introduction means 6) until the first predefined level L1 is reached. This operation will be repeated repeatedly until a condition is reached in which the linen will be substantially completely soaked (a situation in which there is no longer a drop in the level of washing liquid in the compartment 2 due to absorption by the linen). The introduction of the washing liquid to compensate for the drop in level dictated by the absorption by the linen is known as a "top-up" in technical jargon.

40 **[0019]** Appropriately, the washing machine 1 comprises means 7 for determining a first parameter associated with the quantity of washing liquid introduced into the

compartment 2 to top up said first level L1 and compensate for the absorption of liquid by the linen. The first parameter in the preferred embodiment is actually the sum of the quantity of liquid introduced during the top-ups. In limit cases, the sum could coincide with the quantity of water introduced in a single top-up or could also be equal to zero (as is also clear from a mathematical point of view if there are no top-ups).

[0020] The machine 1 also comprises comparison means 8 of said first parameter with predetermined intervals of said first parameter. Each of said intervals is associated with a corresponding set of parameters connected with the quantity of water to be used in the rinse step.

[0021] As also indicated below, such a set of parameters could comprise, for example: number of rinses (the number of rinses could also be equal to "1"), quantity of water to be introduced in each rinse, duration of each individual rinse, etc..

[0022] In the preferred embodiment, the washing machine 1 comprises an electronic control system (for example a main electronic board). The means 7 for determining said first parameter and the aforementioned comparison means 8 are integrated into said electronic control system (e.g. they are integrated into the same electronic board).

[0023] The machine 1 further comprises a selector 9 of the type of linen to be washed. Such a selector 9 could be a knob, a button or a touch screen, etc. It allows the user to choose from a discrete list of items the one he intends to use for washing. The selector 9 is manually activated by the user. In a particular, but non-limiting embodiment, the set of parameters connected with the quantity of water to be used in the rinse step varies as the setting of said selector 9 varies. The utility of the selector 9 is particularly clear in the event of determined items such as quilts, for example. In fact, the applicant has verified that with determined and limited types of products it may be useful to use a specific quantity of water for that type of items by forcing the pre-set optimised algorithm in the machine 1.

[0024] The present invention relates to an operating method of a linen washing machine 1 (in Figure 1 the linen is schematically indicated by the reference letter "P"). This method enables the quantity of rinsing water to be used during the rinse to be optimised. This method can be advantageously implemented by a linen washing machine having one or more of the characteristics described above (for that reason some of the concepts already described will be referred to again below). The washing machine first performs an actual washing cycle followed by a rinse step.

[0025] The rinse step usually serves the purpose of removing any residue of detergent used in the actual washing step. Typically, but not necessarily, in the rinse step only water is used. The rinse step may envisage the implementation of a plurality of rinses. Each rinse usually envisages the full replacement of the water contained in

the compartment 2. In any case, the distinction between the washing cycle and the rinse step is well known in the technical field.

[0026] The method comprises the steps of loading a washing liquid into a washing compartment 2. In the present text washing liquid means a liquid comprising water and any chemical products (detergents, softener, etc.).

[0027] Appropriately the washing liquid loading step takes place at the start of a washing step. The washing liquid loading step comprises the step of introducing the washing liquid until a first predefined level L1 is initially reached. Such first level L1 is set by a level sensor 4. The washing compartment 2 contains a drum 3 that can rotate and that is suitable for housing the linen to be washed. The drum 3 can rotate with respect to the axis 31 indicated in Figure 1.

[0028] The first level L1 surpasses a lower portion 30 of the drum 3. The first level L1 therefore affects the linen placed in the drum 3.

[0029] The washing liquid loading step also envisages introducing into the compartment 2 a top-up liquid following the partial absorption by the linen of the washing liquid already contained in the compartment 2. It is specified that once the top-up liquid has been introduced into the compartment 2 it is also considered washing liquid.

[0030] In a preferred embodiment the top-up liquid introduction step envisages repeatedly topping up the first level L1 by adding top-up liquid to compensate for the washing liquid absorbed by the linen. The top-up liquid may or may not be of the same type as the washing liquid already contained in the compartment 2.

[0031] The top-up liquid is normally added once the level in the compartment 2 in a time span predetermined by the reaching of the first level L1 drops below the second predefined level L2. During such time span, the drum 3 is advantageously placed in rotation in order to promote the absorption of the liquid by the linen contained therein.

[0032] In the preferred embodiment the repetition ends when at the end of a time span predetermined by the last reaching of the level L1, a lower level than the second predefined level L2 is not detected.

[0033] In practice, at the end of the above-indicated repetition, the linen will be soaked.

[0034] Advantageously the method also comprises the step of determining a first parameter univocally associated with the quantity of top-up liquid introduced into the compartment 2.

[0035] In a particular embodiment the step of determining a first parameter univocally associated with the quantity of top-up liquid envisages:

- determining the flow rate of the washing liquid introduced into the compartment 2 through the solenoid valve 5 (this allows the real flow rate of the solenoid valve 5 to be determined in order to take into consideration the effective pressure value of the water supply network and/or any deposits);

- counting the time in which the solenoid valve 5 is open during said step of repeatedly topping up the first predefined level L1;

[0036] In that case, the first parameter could be equal or directly proportional to the product of the flow rate and the time in which the solenoid valve 5 remains open during said step of repeatedly topping up the first predefined level L1. Said time is usually equal to the sum of a number of time intervals corresponding to each repetition, but could also correspond to a single time interval (in this case there would only be one top-up); furthermore, in the event that there are no top-ups such time could also be null. The situation in which there are no top-ups is a situation that could arise if items to be washed, which absorb very little water, are placed in the compartment 2.

[0037] A particularly advantageous way of determining the water flow rate (and therefore estimating the first parameter as indicated above) envisages measuring the time that, with the solenoid valve 5 open, the level of liquid in the compartment 2 takes to rise from one pre-established reference level L3 to said first predefined level L1, said flow rate being a function of the ratio between a first volume and a first time interval (the first volume is equal to the volume of the liquid interposed between the pre-established reference level L3 and the first predefined level L1; the first time interval is equal to the time that, with the solenoid valve 5 open, the level of liquid in the compartment 2 takes to rise from the pre-established reference level L3 to said first predefined level L1).

[0038] In an embodiment shown by way of non-limiting example, the step of measuring the time that, with the solenoid valve 5 open, the level of liquid in the compartment 2 takes to pass from a pre-established reference level L3 to said predefined level L1 takes place during the step (already defined above) of introducing the washing liquid until the initial reaching of the first level L1.

[0039] The method therefore envisages determining a set of parameters associated with the quantity of water to be used in a linen rinse step. The step of determining said set of parameters envisages comparing said first parameter (determined for example according to the indications provided above) with corresponding predetermined intervals of said first parameter.

[0040] Such intervals are consecutive to each other. Typically the higher the flow rate of the water introduced through the top-ups, the higher the value of said first parameter will be. Each of said intervals of the first parameter corresponds to a set of parameters associated with the quantity of water to be used in the rinse step. The higher the quantity of washing liquid loaded through the top-ups, the higher the quantity of water to be used in the rinse step will be. In fact, the quantity of washing liquid introduced with the top-ups provides an indication of the absorption by the linen. The absorption may vary greatly not only as the mass of the load varies (as the mass increases the absorption increases), but also according to its type (e.g. a cushion of the same mass absorbs more

liquid than a pair of shoes). The quantity of water to be used during the rinse is optimised by connecting such a variable with the absorption of liquid by the linen.

[0041] The step of determining the set of parameters associated with the quantity of water to be used in a linen rinse step envisages determining at least the number of rinse cycles to be performed in the rinse step and/or the quantity of water to be introduced in each rinse cycle and/or the duration of each rinse cycle (from which the overall duration of the rinse cycle could immediately be derived).

[0042] In particular, the step of determining the quantity of water to be introduced in each rinse cycle envisages determining the opening time of the solenoid valve 5 in each rinse cycle or the various levels which when reached in each rinse cycle determine the stopping of the introduction of water into the compartment 2.

[0043] The method finally envisages performing a rinse step by adopting the set of parameters corresponding to the interval identified by said comparison step of said first parameter with corresponding pre-determined intervals of such first parameter.

[0044] The present invention enables many advantages to be attained. First of all, it enables an optimised estimate to be made of the water to be used in the rinse step considering the real requirements of the load (therefore not only influenced by the mass or only by the type of load). A further important advantage is connected with the possibility to directly associate, through a precise correspondence, said first parameter (connected with the absorption of the washing liquid) with said set of parameters (connected with the rinse cycle) without needing to use complicated calculation algorithms (which would require a suitably sized and expensive processor). According to the invention said set of parameters (connected with the rinse) can vary discretely as a function of the interval assumed by the first parameter.

[0045] The invention as conceived is susceptible to numerous modifications and variants, all falling within the scope of the inventive concept characterised thereby. Furthermore all the details can be replaced by other technically equivalent elements. In practice, all the materials used, as well as the dimensions, can be any according to requirements.

Claims

1. An operating method of a linen washing machine (1) comprising the *step* of:
 - i) loading a washing liquid into a washing compartment (2), said washing compartment (2) containing a drum (3) that can rotate and that houses the linen to be washed, said step of loading the washing liquid comprising:

- a step of introducing the washing liquid

until a first pre-defined level (L1) is reached, said first level (L1) surmounting a lower portion (30) of the drum (3);

- introducing into the compartment (2) a top-up liquid following a pre-determined absorption by the linen of the washing liquid already contained in the compartment (2); the top-up liquid once introduced into the compartment (2) also being considered washing liquid;

the method being characterised by further comprising the steps of:

ii) determining a first parameter univocally associated with the quantity of top-up liquid introduced into the compartment (2);

iii) determining a set of parameters associated with a quantity of water to be used in a rinse step of the linen, wherein the step of determining said set of parameters envisages a comparison of said first parameter with corresponding pre-determined intervals of such first parameter, **wherein each of said intervals is associated with a corresponding set of parameters associated with the quantity of water to be used in a rinse step;**

iv) performing a rinse step by adopting the set of parameters corresponding to the interval identified by said comparison step of said first parameter with corresponding pre-determined intervals of such first parameter.

2. The method according to claim 1, **characterised in that** the step of determining the set of parameters associated with the quantity of water to be used in the linen rinse step envisages determining at least the number of rinse cycles to be performed in the rinse step and/or the quantity of water to be introduced in each rinse cycle and/or the duration of each rinse cycle.

3. The method according to claim 2, **characterised in that** the step of determining the quantity of water to be introduced in each rinse cycle envisages determining, for each rinse cycle, the opening time of the solenoid valve (5) or the level that determines the stopping of the introduction of water into the compartment (2).

4. The method according to any one of the previous claims, **characterised in that** the step of determining a first parameter univocally associated with the quantity of top-up liquid envisages:

- determining the flow rate of the washing liquid introduced into the compartment (2) through the solenoid valve (5);

- counting the time in which the solenoid valve (5) is open during said step of introducing the top-up liquid;

said first parameter being proportional to the product of the flow rate and the time in which the solenoid valve (5) remains open during said step of introducing the top-up liquid.

5. The method according to claim 4, **characterised in that** the step of determining the water flow rate envisages measuring the time that, with the solenoid valve (5) open, the level of the washing liquid in the compartment (2) takes to rise from one pre-established reference level (L3) to said first pre-defined level (L1), said flow rate being a function of the ratio between a first volume and a first time interval; said first volume being equal to the volume of the liquid interposed between the pre-established reference level (L3) and the first pre-defined level (L1); said first time interval being equal to the time that, with the solenoid valve (5) open, the level of washing liquid in the compartment (2) takes to rise from the pre-established reference level (L3) to said first pre-defined level (L1).

6. The method according to any one of the previous claims, **characterised in that** the step of introducing the top-up liquid envisages repeatedly topping up the first pre-defined level (L1) by adding top-up liquid to compensate the washing liquid already contained in the compartment (2) and absorbed by the linen.

7. The method according to claim 6, **characterised in that** the step of repeatedly topping up the first pre-defined level (L1) envisages that every repeat only takes place if within a pre-determined time span from the last reaching of the first level (L1) the level in the compartment (2) has dropped below a second pre-defined level (L2); the second pre-defined level (L2) being lower than the first pre-defined level (L1); during at least a part of said time span the drum (3) within the compartment (2) and containing the linen being made to rotate so as to promote the absorption of the washing liquid by the linen itself.

8. A linen washing machine comprising:

- a washing compartment (2);
 - a washing liquid level sensor (4) in said compartment (2), said level sensor (4) identifying a first operating condition in which the level measured is higher than a first pre-defined level (L1) and a second operating condition in which the level measured is lower than a second pre-defined level (L2);
 - means (6) for introducing the washing liquid into the compartment (2) operatively associated

with the level sensor (4) and that when the first and the second operating condition arise respectively stop and activate the introduction of the washing liquid into the compartment (2);

the machine being characterised by further comprising:

- means (7) for determining a first parameter associated with the quantity of washing liquid introduced into the compartment (2) to compensate the absorption of the liquid by the linen during a step of loading the washing liquid;
- means (8) for comparing said first parameter with pre-determined intervals of said first parameter, **wherein each of said intervals is associated with** a corresponding set of parameters connected with the quantity of water to be used in the rinse step;
- means for performing a rinse step by adopting the set of parameters corresponding to the interval identified by said comparison step of said first parameter with corresponding pre-determined intervals of such first parameter.

9. The machine according to claim 8, **characterised in that** the means (7) for determining a first parameter associated with the quantity of washing liquid introduced into the compartment (2) to compensate the absorption of the liquid by the linen during a step of loading the washing liquid are determination means (7) of a first parameter associated with the quantity of washing liquid introduced into the compartment (2) for topping up said first pre-defined level (L1).
10. The machine according to claim 8 or 9, **characterised in that** it 5 comprises a selector (9) of the type of linen to be washed, said selector (9) being activated manually by a user; said set of parameters varying as the setting of said selector (9) varies.

Patentansprüche

1. Betriebsverfahren für eine Textilwaschmaschine (1), das folgenden Schritt umfasst:

i) Einfüllen einer Waschflüssigkeit in einen Waschbottich (2), wobei der Waschbottich (2) eine Trommel (3) umfasst, die sich drehen kann und die die zu waschenden Textilien aufnimmt, wobei der Schritt des Einfüllens der Waschflüssigkeit Folgendes umfasst:

- einen Schritt zum Einleiten der Waschflüssigkeit, bis ein erster zuvor festgelegter Füllstand (L1) erreicht ist, wobei der erste Füll-

stand (L1) höher ist als ein unterer Abschnitt (30) der Trommel (3);

- Einleiten, in den Bottich (2), einer Nachfüllflüssigkeit im Anschluss an eine zuvor festgelegte Absorption der bereits in dem Bottich (2) enthaltenen Waschflüssigkeit durch die Textilien; wobei die Nachfüllflüssigkeit, nachdem sie in den Bottich (2) eingeleitet wurde, ebenfalls als Waschflüssigkeit angesehen wird;

wobei das Verfahren **dadurch gekennzeichnet ist, dass** es des Weiteren folgende Schritte umfasst:

- ii) Bestimmen eines ersten Parameters, der eindeutig der Menge der in den Bottich (2) eingeleiteten Nachfüllflüssigkeit zugeordnet ist;
- iii) Bestimmen eines Satzes von Parametern, die einer Menge an Wasser zugeordnet sind, das in einem Spülschritt für die Textilien eingeleitet werden soll, wobei der Schritt des Bestimmens des Satzes von Parametern einen Vergleich des ersten Parameters mit entsprechenden zuvor festgelegten Intervallen dieses ersten Parameters vorsieht, wobei jedes der Intervalle einem entsprechenden Satz von Parametern zugeordnet ist, die der Menge an Wasser zugeordnet sind, das in einem Spülschritt verwendet werden soll;
- iv) Ausführen eines Spülschrittes unter Verwendung des Satzes von Parametern, die dem Intervall entsprechen, das durch den Schritt des Vergleichens des ersten Parameters mit entsprechenden vorgegebenen Intervallen dieses ersten Parameters identifiziert wurde.

2. Verfahren nach Anspruch 1, **dadurch gekennzeichnet, dass** der Schritt des Bestimmens des Satzes von Parametern, die der Menge an Wasser zugeordnet sind, das in dem Textilien-Spülschritt zu verwenden ist, das Bestimmen mindestens der Anzahl von Spülzyklen, die in dem Spülschritt auszuführen sind, und/oder die Menge an Wasser, das in jedem Spülzyklus einzuleiten ist, und/oder die Dauer jedes Spülzyklus vorsieht.

3. Verfahren nach Anspruch 2, **dadurch gekennzeichnet, dass** der Schritt des Bestimmens der Menge an Wasser, das in jedem Spülzyklus einzuleiten ist, das Bestimmen, für jeden Spülzyklus, die Öffnungszeit des Solenoidventils (5) oder des Füllstandes, der das Stoppen des Einleitens von Wasser in den Bottich (2) vorsieht.

4. Verfahren nach einem der vorangehenden Ansprüche, **dadurch gekennzeichnet, dass** der Schritt des Bestimmens eines ersten Parameters, der eindeutig der Menge an Nachfüllflüssigkeit zugeordnet,

Folgendes vorsieht:

- Bestimmen der Strömungsrate der durch das Solenoidventil (5) in den Bottich (2) eingeleiteten Waschflüssigkeit;
- Zählen der Zeit, in der das Solenoidventil (5) während des Schrittes zum Einleiten der Nachfüllflüssigkeit offen ist;

wobei der erste Parameter zu dem Produkt der Strömungsrate und der Zeit, in der das Solenoidventil (5) während des Schrittes zum Einleiten der Nachfüllflüssigkeit offen bleibt, proportional ist.

5. Verfahren nach Anspruch 4, **dadurch gekennzeichnet, dass** der Schritt des Bestimmens der Wasserströmungsrate vorsieht, die Zeit zu messen, die es bei geöffnetem Solenoidventil (5) dauert, bis der Füllstand der Waschflüssigkeit in dem Bottich (2) von einem zuvor festgelegten Referenzfüllstand (L3) zu dem ersten zuvor festgelegten Füllstand (L1) ansteigt, wobei die Strömungsrate eine Funktion des Verhältnisses zwischen einem ersten Volumen und einem ersten Zeitintervall ist; wobei das erste Volumen gleich dem Volumen der Flüssigkeit ist, die sich zwischen dem zuvor festgelegten Referenzfüllstand (L3) und dem ersten zuvor festgelegten Füllstand (L1) befindet; wobei das erste Zeitintervall gleich der Zeit ist, die es bei geöffnetem Solenoidventil (5) dauert, bis der Füllstand der Waschflüssigkeit in dem Bottich (2) von einem zuvor festgelegten Referenzfüllstand (L3) zu dem ersten zuvor festgelegten Füllstand (L1) ansteigt.

6. Verfahren nach einem der vorangehenden Ansprüche, **dadurch gekennzeichnet, dass** der Schritt zum Einleiten der Nachfüllflüssigkeit vorsieht, den ersten zuvor festgelegten Füllstand (L1) wiederholt nachzufüllen, indem Nachfüllflüssigkeit zugegeben wird, um die bereits in dem Bottich (2) enthaltene Waschflüssigkeit, die durch die Textilien absorbiert wurde, zu kompensieren.

7. Verfahren nach Anspruch 6, **dadurch gekennzeichnet, dass** der Schritt des wiederholten Nachfüllens des ersten zuvor festgelegten Füllstandes (L1) vorsieht, dass jede Wiederholung nur stattfindet, wenn innerhalb einer vorgegebenen Zeitspanne ab dem letzten Erreichen des ersten Füllstandes (L1) der Füllstand in dem Bottich (2) unter einen zweiten zuvor festgelegten Füllstand (L2) gesunken ist; wobei der zweite zuvor festgelegte Füllstand (L2) niedriger ist als der erste zuvor festgelegte Füllstand (L1); wobei während mindestens eines Teils der Zeitspanne die Trommel (3) innerhalb des Bottichs (2), in der sich die Textilien befinden, gedreht wird, um die Absorption der Waschflüssigkeit durch die Textilien selbst zu verbessern.

8. Textilwaschmaschine, die Folgendes umfasst:

- einen Waschbottich (2);
- einen Waschflüssigkeit-Füllstandssensor (4) in dem Bottich (2), wobei der Füllstandssensor (4) einen ersten Betriebszustand identifiziert, in dem der gemessene Füllstand höher ist als ein erster zuvor festgelegter Füllstand (L1), und einen zweiten Betriebszustand identifiziert, in dem der gemessene Füllstand niedriger ist als ein zweiter zuvor festgelegter Füllstand (L2);
- ein Mittel (6) zum Einleiten der Waschflüssigkeit in den Bottich (2), das funktional dem Füllstandssensor (4) zugeordnet ist, und das, wenn der erste und der zweite Betriebszustand eintritt, das Einleiten der Waschflüssigkeit in den Bottich (2) stoppt bzw. aktiviert;

wobei die Maschine **dadurch gekennzeichnet ist, dass** sie des Weiteren Folgendes umfasst:

- ein Mittel (7) zum Bestimmen eines ersten Parameters, welcher der Menge an Waschflüssigkeit zugeordnet ist, die in den Bottich (2) eingeleitet wird, um die Absorption der Flüssigkeit durch die Textilien während eines Schrittes des Einfüllens der Waschflüssigkeit zu kompensieren;
- ein Mittel (8) zum Vergleichen des ersten Parameters mit vorgegebenen Intervallen des ersten Parameters, wobei jedes der Intervalle einem entsprechenden Satz von Parametern zugeordnet ist, die mit der Menge an Wasser verbunden sind, das in dem Spülschritt zu verwenden ist;
- ein Mittel zum Ausführen eines Spülschrittes unter Verwendung des Satzes von Parametern, die dem Intervall entsprechen, das durch den Schritt des Vergleichs des ersten Parameters mit entsprechenden vorgegebenen Intervallen dieses ersten Parameters identifiziert wurde.

9. Maschine nach Anspruch 8, **dadurch gekennzeichnet, dass** das Mittel (7) zum Bestimmen eines ersten Parameters, welcher der Menge an Waschflüssigkeit zugeordnet ist, die in den Bottich (2) eingeleitet wird, um die Absorption der Flüssigkeit durch die Textilien während einen Schritt des Einfüllens der Waschflüssigkeit zu kompensieren, ein Mittel (7) zum Bestimmen eines ersten Parameters ist, welcher der Menge Waschflüssigkeit zugeordnet, die in den Bottich (2) eingeleitet wurde, um den ersten zuvor festgelegten Füllstand (L1) aufzufüllen.

10. Maschine nach Anspruch 8 oder 9, **dadurch gekennzeichnet, dass** sie einen Wählschalter (9) für die Art der zu waschenden Textilien umfasst, wobei der Wählschalter (9) manuell durch einen Nutzer ak-

tiviert wird; wobei der Satz von Parametern variiert, wenn die Einstellung des Wählschalters (9) variiert wird.

Revendications

1. Procédé de fonctionnement d'une machine à laver le linge (1) comprenant l'étape consistant à :

i) charger un liquide de lavage dans un compartiment de lavage (2), ledit compartiment de lavage (2) contenant un tambour (3) qui peut tourner et qui reçoit le linge à laver, ladite étape de chargement du liquide de lavage comprenant :

- une étape d'introduction du liquide de lavage jusqu'à ce qu'un premier niveau prédéfini (L1) soit atteint, ledit premier niveau (L1) dépassant une partie inférieure (30) du tambour (3) ;
- l'introduction dans le compartiment (2) d'un liquide d'appoint après une absorption prédéterminée par le linge du liquide de lavage déjà contenu dans le compartiment (2) ; le liquide d'appoint une fois introduit dans le compartiment (2) étant également considéré comme liquide de lavage ;

le procédé étant **caractérisé en ce qu'il** comprend en outre les étapes consistant à :

- i) déterminer un premier paramètre associé de manière univoque à la quantité de liquide d'appoint introduite dans le compartiment (2) ;
- ii) déterminer un ensemble de paramètres associé à une quantité d'eau à utiliser dans une étape de rinçage du linge, dans lequel l'étape de détermination dudit ensemble de paramètres envisage une comparaison dudit premier paramètre à intervalles prédéterminés correspondants d'un tel premier paramètre, dans lequel chacun desdits intervalles est associé à un ensemble correspondant de paramètres associés à la quantité d'eau à utiliser dans une étape de rinçage ;
- v) effectuer une étape de rinçage en adoptant l'ensemble de paramètres correspondant à l'intervalle identifié par ladite étape de comparaison dudit premier paramètre à intervalles prédéterminés correspondants d'un tel premier paramètre.

2. Procédé selon la revendication 1, **caractérisé en ce que** l'étape de détermination de l'ensemble de paramètres associé à la quantité d'eau à utiliser dans une étape de rinçage du linge envisage la détermination d'au moins le nombre de cycles de rinçage à

effectuer dans l'étape de rinçage et/ou de la quantité d'eau à introduire dans chaque cycle de rinçage et/ou de la durée de chaque cycle de rinçage.

3. Procédé selon la revendication 2, **caractérisé en ce que** l'étape de détermination de la quantité d'eau à introduire dans chaque cycle de rinçage envisage la détermination, pour chaque cycle de rinçage, du temps d'ouverture de l'électrovanne (5) ou du niveau qui détermine l'arrêt de l'introduction d'eau dans le compartiment (2).

4. Procédé selon l'une quelconque des revendications précédentes, **caractérisé en ce que** l'étape de détermination d'un premier paramètre associé de manière univoque à la quantité de liquide d'appoint envisage :

- la détermination du débit du liquide de lavage introduit dans le compartiment (2) via l'électrovanne (5) ;
- le comptage du temps pendant lequel l'électrovanne (5) est ouverte au cours de ladite étape d'introduction du liquide d'appoint ;

ledit premier paramètre étant proportionnel au produit du débit et du temps pendant lequel l'électrovanne (5) reste ouverte au cours de ladite étape d'introduction du liquide d'appoint.

5. Procédé selon la revendication 4, **caractérisé en ce que** l'étape de détermination du débit d'eau envisage la mesure du temps que, avec l'électrovanne (5) ouverte, le niveau du liquide de lavage dans le compartiment (2) prend pour augmenter d'un niveau de référence préétabli (L3) audit premier niveau prédéfini (L1), ledit débit étant fonction du rapport entre un premier volume et un premier intervalle de temps ; ledit premier volume étant égal au volume du liquide intercalé entre le niveau de référence préétabli (L3) et le premier niveau prédéfini (L1) ; ledit premier intervalle de temps étant égal au temps que, avec l'électrovanne (5) ouverte, le niveau de liquide de lavage dans le compartiment (2) prend pour augmenter du niveau de référence préétabli (L3) audit premier niveau prédéfini (L1).

6. Procédé selon l'une quelconque des revendications précédentes, **caractérisé en ce que** l'étape d'introduction du liquide d'appoint envisage de manière répétée le remplissage d'appoint du premier niveau prédéfini (L1) en ajoutant du liquide d'appoint pour compenser le liquide de lavage déjà contenu dans le compartiment (2) et absorbé par le linge.

7. Procédé selon la revendication 6, **caractérisé en ce que** l'étape de remplissage d'appoint répété du premier niveau prédéfini (L1) envisage que chaque ré-

pétition n'ait lieu que si, dans un intervalle de temps prédéterminé depuis que l'on a atteint en dernier lieu le premier niveau (L1), le niveau dans le compartiment (2) a chuté en dessous d'un second niveau prédéfini (L2) ; le second niveau prédéfini (L2) étant inférieur au premier niveau prédéfini (L1) ; au cours d'au moins une partie dudit intervalle de temps, le tambour (3) à l'intérieur du compartiment (2) contenant le linge étant entraîné en rotation de manière à favoriser l'absorption du liquide de lavage par le linge lui-même.

8. Machine de lavage de linge comprenant :

- un compartiment de lavage (2) ;
- un capteur de niveau de liquide de lavage (4) dans ledit compartiment (2), ledit capteur de niveau (4) identifiant un premier état de fonctionnement dans lequel le niveau mesuré est supérieur à un premier niveau prédéfini (L1) et un second état de fonctionnement dans lequel le niveau mesuré est inférieur à un second niveau prédéfini (L2) ;
- des moyens (6) pour introduire le liquide de lavage dans le compartiment (2) associés en service au capteur de niveau (4) et qui, lorsque le premier et le second état de fonctionnement se produisent, arrêtent et activent respectivement l'introduction du liquide de lavage dans le compartiment (2) ;

la machine étant **caractérisée en ce qu'elle** comprend en outre :

- des moyens (7) pour déterminer un premier paramètre associé à la quantité de liquide de lavage introduite dans le compartiment (2) pour compenser l'absorption du liquide par le linge au cours d'une étape de chargement du liquide de lavage ;
- des moyens (8) pour comparer ledit premier paramètre à intervalles prédéterminés dudit premier paramètre, dans lequel chacun desdits intervalles est associé à un ensemble correspondant de paramètres raccordés à la quantité d'eau à utiliser dans l'étape de rinçage ;
- des moyens pour effectuer une étape de rinçage en adoptant l'ensemble de paramètres correspondant à l'intervalle identifié par ladite étape de comparaison dudit premier paramètre à intervalles prédéterminés correspondants d'un tel premier paramètre.

9. Machine selon la revendication 8, caractérisée en que les moyens (7) pour déterminer un premier paramètre associé à la quantité de liquide de lavage introduite dans le compartiment (2) pour compenser l'absorption du liquide par le linge au cours d'une

étape de chargement du liquide de lavage sont des moyens de détermination (7) d'un premier paramètre associé à la quantité de liquide de lavage introduite dans le compartiment (2) pour effectuer un remplissage d'appoint audit premier niveau prédéfini (L1).

10. Machine selon la revendication 8 ou 9, **caractérisée en ce qu'elle** comprend un sélecteur (9) du type de linge à laver, ledit sélecteur (9) étant activé manuellement par un utilisateur ; ledit ensemble de paramètres variant lorsque le réglage dudit sélecteur (9) varie.

FIG 1

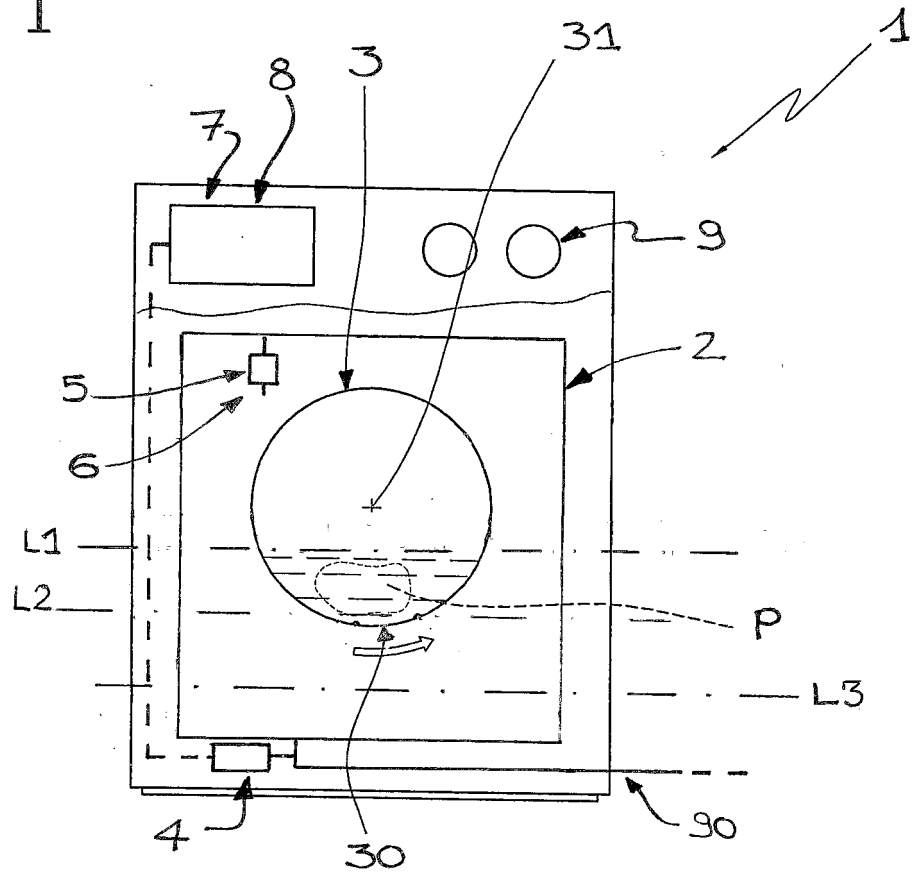

REFERENCES CITED IN THE DESCRIPTION

This list of references cited by the applicant is for the reader's convenience only. It does not form part of the European patent document. Even though great care has been taken in compiling the references, errors or omissions cannot be excluded and the EPO disclaims all liability in this regard.

Patent documents cited in the description

- US 2008189875 A1 [0006]
- EP 1281803 A1 [0006]