



INTERNATIONAL APPLICATION PUBLISHED UNDER THE PATENT COOPERATION TREATY (PCT)

(51) International Patent Classification ⁷ : G01N 27/327, C12Q 1/00, A61M 5/142	A1	(11) International Publication Number: WO 00/33065 (43) International Publication Date: 8 June 2000 (08.06.00)
<p>(21) International Application Number: PCT/US99/28733</p> <p>(22) International Filing Date: 2 December 1999 (02.12.99)</p> <p>(30) Priority Data: 60/110,684 2 December 1998 (02.12.98) US</p> <p>(71) Applicants (for all designated States except US): LOCKHEED MARTIN ENERGY RESEARCH CORPORATION [US/US]; 701 Scarboro Road, P.O. Box 2009, Oak Ridge, TN 37831-8243 (US). THE UNIVERSITY OF TENNESSEE RESEARCH CORPORATION [US/US]; Suite 403, 1534 White Avenue, Knoxville, TN 37996-1527 (US).</p> <p>(72) Inventors; and (75) Inventors/Applicants (for US only): SAYLER, Gary, S. [US/US]; Route 2, Box 60, McKinney Road, Blain, TN 37709 (US). SIMPSON, Michael, L. [US/US]; 7745 Nubbin Ridge Road, Knoxville, TN 37919 (US). APPLGATE, Bruce, M. [US/US]; 3700 Sutherland Avenue, Knoxville, TN 37919 (US). RIPP, Steven, A. [US/US]; 6020 Sunbeam Lane, #137, Knoxville, TN 37906 (US).</p> <p>(74) Agent: MOORE, Mark, D.; Williams, Morgan & Amerson, P.C., 7676 Hillmont, Suite 250, Houston, TX 77040 (US).</p>	<p>(81) Designated States: AE, AL, AM, AT, AU, AZ, BA, BB, BG, BR, BY, CA, CH, CN, CR, CU, CZ, DE, DK, DM, EE, ES, FI, GB, GD, GE, GH, GM, HR, HU, ID, IL, IN, IS, JP, KE, KG, KP, KR, KZ, LC, LK, LR, LS, LT, LU, LV, MA, MD, MG, MK, MN, MW, MX, NO, NZ, PL, PT, RO, RU, SD, SE, SG, SI, SK, SL, TJ, TM, TR, TT, TZ, UA, UG, US, UZ, VN, YU, ZA, ZW, ARIPO patent (GH, GM, KE, LS, MW, SD, SL, SZ, TZ, UG, ZW), Eurasian patent (AM, AZ, BY, KG, KZ, MD, RU, TJ, TM), European patent (AT, BE, CH, CY, DE, DK, ES, FI, FR, GB, GR, IE, IT, LU, MC, NL, PT, SE), OAPI patent (BF, BJ, CF, CG, CI, CM, GA, GN, GW, ML, MR, NE, SN, TD, TG).</p> <p>Published <i>With international search report. Before the expiration of the time limit for amending the claims and to be republished in the event of the receipt of amendments.</i></p>	
(54) Title: <i>IN VIVO</i> BIOSENSOR APPARATUS AND METHOD OF USE		
<p>(57) Abstract</p> <p>Disclosed are bioluminescent bioreporter integrated circuit devices that detect select analytes in fluids when implanted in the body of an animal. The device comprises a bioreporter that has been genetically engineered to contain a nucleic acid segment that comprises a <i>cis</i>-activating response element that is responsive to the selected substance operably linked to a gene encoding a bioluminescent reporter polypeptide. In preferred embodiments, the target analyte is glucose, glucagons, or insulin. Exposure of the bioreporter to the target substance causes the response element to up-regulate the nucleic acid sequence encoding the reporter polypeptide to produce a luminescent response that is detected and quantitated. In illustrative embodiments, the bioreporter device is encapsulated on an integrated circuit that is capable of detecting the emitted light, processing the resultant signal, and then remotely reporting the results. Also disclosed are controlled drug delivery systems capable of being directly or indirectly controlled by the detection device that provide drugs such as insulin to the animal in response to the amount of target analyte present in the body fluids.</p>		

FOR THE PURPOSES OF INFORMATION ONLY

Codes used to identify States party to the PCT on the front pages of pamphlets publishing international applications under the PCT.

AL	Albania	ES	Spain	LS	Lesotho	SI	Slovenia
AM	Armenia	FI	Finland	LT	Lithuania	SK	Slovakia
AT	Austria	FR	France	LU	Luxembourg	SN	Senegal
AU	Australia	GA	Gabon	LV	Latvia	SZ	Swaziland
AZ	Azerbaijan	GB	United Kingdom	MC	Monaco	TD	Chad
BA	Bosnia and Herzegovina	GE	Georgia	MD	Republic of Moldova	TG	Togo
BB	Barbados	GH	Ghana	MG	Madagascar	TJ	Tajikistan
BE	Belgium	GN	Guinea	MK	The former Yugoslav Republic of Macedonia	TM	Turkmenistan
BF	Burkina Faso	GR	Greece	ML	Mali	TR	Turkey
BG	Bulgaria	HU	Hungary	MN	Mongolia	TT	Trinidad and Tobago
BJ	Benin	IE	Ireland	MR	Mauritania	UA	Ukraine
BR	Brazil	IL	Israel	MW	Malawi	UG	Uganda
BY	Belarus	IS	Iceland	MX	Mexico	US	United States of America
CA	Canada	IT	Italy	NE	Niger	UZ	Uzbekistan
CF	Central African Republic	JP	Japan	NL	Netherlands	VN	Viet Nam
CG	Congo	KE	Kenya	NO	Norway	YU	Yugoslavia
CH	Switzerland	KG	Kyrgyzstan	NZ	New Zealand	ZW	Zimbabwe
CI	Côte d'Ivoire	KP	Democratic People's Republic of Korea	PL	Poland		
CM	Cameroon	KR	Republic of Korea	PT	Portugal		
CN	China	KZ	Kazakstan	RO	Romania		
CU	Cuba	LC	Saint Lucia	RU	Russian Federation		
CZ	Czech Republic	LI	Liechtenstein	SD	Sudan		
DE	Germany	LK	Sri Lanka	SE	Sweden		
DK	Denmark	LR	Liberia	SG	Singapore		
EE	Estonia						

DESCRIPTION

IN VIVO BIOSENSOR APPARATUS AND METHOD OF USE

5 1.0 BACKGROUND OF THE INVENTION

The present application is a continuing application that claims priority to United States Provisional Application Serial Number 60/110,684, filed December 2, 1998, the entire contents of which is specifically incorporated herein by reference in its entirety.

10 The United States government has certain rights in the present invention pursuant to grant number R21RR14169-01 from the National Institutes of Health.

1.1 FIELD OF THE INVENTION

The invention generally relates to the field of implantable diagnostic devices (*i.e.* devices deployed within the body of an animal) for monitoring one or more target substances, analytes, or metabolites in the animal. More particularly, the invention provides implantable biosensor devices for monitoring and regulating the level of analytes in the tissues and circulatory system of a human. In illustrative embodiments, the apparatus comprises a biosensor that is utilized to monitor the level of blood glucose in a diabetic or hypoglycemic patient. The disclosed sensors may also be used to control or regulate the delivery of a drug or other pharmaceutical agent from an external or an implantable drug delivery system. For example, the device may form part of an artificial pancreas to regulate insulin dosage in response to the level of glucose detected *in situ*.

1.2 DESCRIPTION OF RELATED ART

25 1.2.1 BIOSENSORS

Biosensors are hybrid devices combining a biological component with an analytical measuring element. The biological component reacts and/or interacts with the analyte(s) of interest to produce a response measurable by an electronic, optical, or mechanical transducer. The most common configurations presently available utilize immobilized macromolecules such as enzymes or antibodies to form the biological component. Examples of analytes and immobilized macromolecules include: glucose and

immobilized glucose oxidase (*e.g.*, Wilkins *et al.*, 1995); nitrate and immobilized nitrate reductase (Wu *et al.*, 1997); hydrogen peroxide and 2,3-dichlorophenoxyacetic acid and immobilized horseradish peroxidase (Rubtsova *et al.*, 1998); and aspartate and immobilized L-aspartase (Campanella *et al.*, 1995).

5

1.2.2 WHOLE-CELL BIOSENSORS

A further refinement for biosensors has been developed in recent years that utilizes intact living cells, such as a microorganism, or an eukaryotic cell or cell culture as an alternative to immobilized enzymes. Microbial cells are especially well suited for biosensor technologies; they are physically robust, capable of existing under extremely harsh and widely fluctuating environmental conditions, they possess an extensive repertoire of responses to their environment, and they can be genetically engineered to generate reporter systems that are highly sensitive to these environmental responses. Polynucleotide sequences that comprise specific promoter sequences are operably linked to a gene or a plurality of genes that encode the desired reporter enzyme(s) and then introduced into and maintained within the living cell. When the target analyte is present, the reporter genes are expressed, generating the enzyme(s) responsible for the production of the measured signal. Commonly used reporter systems have utilized either the β -galactosidase (*lacZ*) or catechol-2,3-dioxygenase (*xylE*) enzymes (Kricka, 1993).

10

15

20

Unfortunately, a limitation of these systems has been that following exposure to the target substance(s), the cells must be destructively lysed and the enzyme(s) isolated. This lysis is then followed by the addition of one or more secondary metabolites to yield a colorimetric signal that is proportional to the concentration of enzyme(s) in solution, providing a means to quantify the concentration of the original target substance.

25

A more recent improvement in such sensors utilizes green fluorescent protein as a reporter system, with the significant advantage that cells do not require destructive assay techniques to produce colorimetric signals. Because a substrate must be added to the green fluorescent protein constructs to first initiate the light response, however, these systems are quite complicated and offer little advantage for detection of analytes *in situ* (Prasher, 1995).

30

1.2.3 *IN VIVO* SENSORS

The development of an integrated *in vivo* implantable glucose monitor was first reported by Wilkins and Atanasov (1995). This system utilizes glucose oxidase immobilized within a micro-bioreactor. This enzyme catalyzes the oxidation of β -D-glucose by molecular oxygen to yield gluconolactone and hydrogen peroxide, with the concentration of glucose being proportional to the consumption of O_2 or the production of H_2O_2 . Unfortunately, the presence of a glucose oxidase inhibitor molecule in the human bloodstream tended to offset proportionality constants, and made the device unsatisfactorily inaccurate for precise glucose monitoring and control (Gough *et al.*, 1997). Also limiting was the device's relatively large size ($\approx 5 \times 7$ cm), which negated its usefulness as an implantable device.

Although several smaller needle-type and microdialysis glucose sensors have since been developed to circumvent size limitations (Gough *et al.*, 1997, Selam, 1997), their reliance on a glucose oxidase enzyme-based system limits their overall effectiveness and reliability.

Several nonspecific electrochemical sensors have also been investigated as potential *in vivo* glucose sensors (*e.g.*, Yao *et al.*, 1994; Larger *et al.*, 1994), but problems including limited sensitivity, instability, and limited long-term reliability have prevented their wide-spread utilization (Patzner *et al.*, 1995). According to Atanasov *et al.* (1997), continuously functioning implantable glucose biosensors with long-term stability have yet to be achieved.

1.3 DEFICIENCIES IN THE PRIOR ART

Despite a significant miniaturization of biosensors during the past decade, they are still relatively large and obtrusive to serve as ideal implantable devices. Current methodologies using mammalian bioluminescent reporter cells require cell lysis and addition of an exogenous substrate to generate a measurable response. Consequently, these cells cannot serve as continuous on-line monitoring devices.

Therefore, there remains a need for the development of a small implantable monolithic (*i.e.* containing both biological and electrical components constructed on a single substrate layer) bioelectronic monitor that is durable, inexpensive, wireless, and

that can communicate remotely to a drug delivery system to provide the controlled delivery of a therapeutic agent such as insulin.

2.0 SUMMARY OF THE INVENTION

5 The present invention overcomes these and other inherent limitations in the prior art by providing implantable apparatus and methods for detecting and quantitating particular analytes in the body of an animal. In particular, the invention provides devices for the *in vivo* detection and quantitation of metabolites, drugs, hormones, toxins, or microorganisms such as viruses in a human or animal. In illustrative embodiments, the invention provides a BBIC device useful for the detection of glucose in a human. Such devices provide for the first time an accurate on-line detector for glucose monitoring, and offer the ability to control the administration of pharmaceutical agents *via* an external or implantable drug delivery system. Also disclosed are BBIC devices for detecting the concentration of signature molecules (*i.e.* proteins released from cancer cells, *etc.*),
10 clotting factors, enzymes and the like, and other analytes present in the bloodstream or interstitial fluid. In the area of oncology, the biosensor devices find utility in both initial and remission monitoring, on-line measurement of the effectiveness of chemotherapy, and stimulation/activity of the immune system. Likewise, the biosensor devices are useful in other areas of medicine, including on-line monitoring for enzymes associated with the occurrence of blood clots (strokes, heart attacks, *etc.*), detection and quantitation of clotting factors (maintain level), hormone replacement, continuous drug monitoring (testing for controlled substances in prisoners, military personnel, *etc.*), monitoring of soldiers exposure to sub-lethal exposure to nerve agents and other debilitating agents, monitor levels of compounds affecting mental illness, and the like.

25 In one embodiment there is provided an implantable monolithic bioelectronic device for detecting an analyte within the body of an animal. In a general sense this device comprises a bioreporter that is operably positioned above a substrate that is on an integrated circuit. The bioreporter is capable of metabolizing the target analyte and emits light consequent to this metabolism when in contact with the analyte. The device further comprises a sensor closely positioned to the integrated circuit that detects the emitted light
30 and generates an electrical signal in proportion to the amount of light generated by the bioreporter. Preferably the entire implantable device is contained within a biocompatible

container that is implanted within the body of the animal in which the analyte detection is desired.

The biocompatible container may be comprised of silicon nitride, silicon oxide, or a suitable polymeric matrix, with exemplary matrices such as polyvinyl alcohol, poly-L-lysine, and alginate being particularly preferred. The polymeric matrix may also further
5 comprise a microporous, mesh-reinforced or a filter-supported hydrogel.

In certain embodiments, it may also be desirable to provide a transparent, biocompatible, bioresistant separator that is operably positioned between the phototransducer and the bioreporter.

The bioreporter preferably comprises a plurality of eukaryotic or prokaryotic cells
10 that produce a bioluminescent reporter polypeptide in response to the presence of the target analyte. Prokaryotic cells such as one or more strains of bacteria, and eukaryotic cells such as mammalian cells are particularly preferred. Exemplary mammalian cells are human cells such as islet β -cells, immortal stem cells, or hepatic cells, with immortal stem
15 cells being particularly preferred.

These cells preferably comprise one or more nucleic acid segments that encode a luciferase polypeptide or a green fluorescent protein that is produced by the cells in response to the presence of the analyte. Preferably the nucleic acid segment encodes an *Aqueorea Victoria*, *Renilla reniformis*, or a humanized green fluorescent protein, or more
20 preferably, a bacterial Lux polypeptide, such as the LuxA, LuxB, LuxC, LuxD, or LuxE polypeptide, or the LuxAB or LuxCDE fused polypeptides described herein.

Exemplary bacterial *lux* gene sequences that may be employed to prepare the genetic constructs include the *Vibrio fischerii* or more preferably, the *Xenorhabdus luminescens luxA*, *luxB*, *luxC*, *luxD*, *luxE*, *luxAB*, or *luxCDE* genes.

Exemplary *lux* gene sequences that may be employed for preparation of the genetic constructs as described herein include the gene sequences disclosed in SEQ ID NO:1. Exemplary Lux polypeptide sequences are disclosed in SEQ ID NO:2, SEQ ID NO:3, SEQ ID NO:4, SEQ ID NO:5 and SEQ ID NO:6.
25

The Lux polypeptides preferably comprise at least a 10 contiguous amino acid
30 sequence from one or more of the polypeptide sequences disclosed in SEQ ID NO:2 through SEQ ID NO:6. More preferably the Lux polypeptides comprise at least a 15 contiguous amino acid sequence from one or more of the polypeptide sequences disclosed

in SEQ ID NO:2 through SEQ ID NO:6, and more preferably still, comprise at least a 20 contiguous amino acid sequence from one or more of the polypeptide sequences disclosed in SEQ ID NO:2 through SEQ ID NO:6.

Such polypeptides are preferably encoded by a nucleic acid sequence that
5 comprises at least 20, at least 25, at least 30, at least 35, at least 40, or at least 45 or more contiguous nucleotides from SEQ ID NO:1.

The expression of the Lux-encoding nucleic acid segments is preferably regulated by a nucleic acid regulatory sequence operably linked to the Lux-encoding segment. Preferably this regulatory sequence comprises a *cis*-acting element that is responsive to
10 the presence of the target analyte. Exemplary *cis*-acting response elements are selected from the group consisting of an S14 gene sequence, a hepatic L-pyruvate kinase gene sequence, a hepatic 6-phosphofructo-2-kinase gene sequence, a β -islets insulin gene sequence, a mesangial transforming growth factor- β gene sequence, and an acetyl-coenzyme-A carboxylase gene sequence.

In an illustrative embodiment, the *cis*-acting response element comprises a
15 contiguous nucleotide sequence from a β -islets insulin gene sequence or a hepatic L-pyruvate kinase gene sequence. Expression of the nucleic acid sequence is preferably regulated by a promoter sequence such as the one derived from an L-pyruvate kinase-encoding gene described herein.

The device may further comprise a wireless transmitter, an antenna, and a source
20 of nutrients capable of sustaining the bioreporter cells. Likewise the biocompatible container enclosing the bioreporter may further comprise a membrane that is permeable to the analyte but not to the bioreporter cells themselves. Such a semi-permeable membrane permits analytes to flow freely from the bodily fluid into the detector device, but restricts
25 the migration of bioreporter cells from the device into the surrounding tissues or circulatory system of the body in which the device is implanted.

In one embodiment, the integrated circuit is a complementary metal oxide semiconductor (CMOS) integrated circuit. The integrated circuit may comprise one or more phototransducer, that themselves may be comprised of one or more photodiodes.
30 Likewise, the integrated circuit may also further comprise a photodiode, a current-to-frequency converter, a digital counter, and/or a transmitter that is capable of transmitting either digital or analog data.

The invention also provides an implantable controlled drug delivery system that comprises both the BBIC device and an implantable drug delivery pump that is capable of being operably controlled by the BBIC and that is capable of delivering the drug to the body of the animal in response to controls by the device. The invention also concerns a method of providing a controlled supply of a drug to a patient in need thereof. The method generally involves implanting within the body of the patient the controlled drug delivery system

The invention also provides a method of determining the amount of a drug required by a patient in need thereof, such as in the case of giving a diabetic patient an appropriate amount of insulin. The method generally involves implanting within the body of the diabetic patient one or more BBIC devices that are responsive to either glucose, glucagons, insulin, or another glucose metabolite, and determining the amount of insulin required by the patient based upon the levels of the analyte detected in the body fluids by the device. When the device indicates that higher levels of insulin are required, the appropriate control signal can be sent to the drug delivery system and more insulin is injected into the body. When the device indicates that lower levels of insulin are required, then the appropriate control signal can be sent to the drug delivery system and less insulin can be administered. Such "real-time" monitoring of glucose in the body of the animal permits for controlled release of insulin throughout the day, and obviates the need for daily or more frequent injections of insulin that may either be too much or too little for the particular time of administration. This affords a more cost-effective administration of the drug, and also provides a more stable dosing of the insulin to the patient on an "as needed" basis.

The invention also provides a kit for the detection of an analyte, and such kits generally will include one or more of the disclosed BBIC devices in combination with appropriate instructions for using the detection device. Such kits may also routinely contain one or more standardized reference solutions for calibrating the device, and may also include suitable storage or nutrient medium for sustaining the bioreporter cells either during storage or during use once implanted within the body of the animal. In the case of therapeutic kits, such kits will also generally include one or more controlled delivery systems for administration of the drug to the body of the animal.

The invention also provides a method of regulating the blood glucose level of an animal in need thereof. This method generally comprises monitoring the level of glucose in the bloodstream or interstitial fluid of the patient using the BBIC device, and administering to the patient an effective amount of an insulin composition sufficient to regulate the blood glucose level.

This new type of bioluminescence-based bioreporter is capable of monitoring target substances without the disadvantageous requirement that cells be destroyed to produce the measurable signal. This allows for monitoring to occur continuously, on-line and in real-time (Simpson *et al.*, 1998a, 1998b). These cells rely on luciferase genes (designated *lux* in prokaryotes and *luc* in eukaryotes) for the reporter enzyme system. U. S. Patent Appl. Ser. No. 08/978,439 and Intl. Pat. Appl. Ser. No. PCT/US98/25295 (each of which is specifically incorporated herein by reference in its entirety) disclose a self-contained miniature bioluminescence bioreporter integrated circuit ("BBIC") that was designed to detect specific molecular targets *ex situ* or *ex vivo*.

The present invention concerns an implantable, or an *in situ* or an *in vivo* BBIC device that is capable of being implanted within the body of an animal, and that is capable of detecting the concentration of one or more analytes present within the animal. The implantable monolithic bioelectronic device of the present invention generally comprises a substrate, a bioreporter capable of responding to a particular substance by the emission of light, a container affixed to the substrate capable of holding the bioreporter, an integrated circuit on the substrate including a phototransducer operative to generate an electrical signal in response to the light wherein the signal indicates the concentration of the substance; and a biocompatible housing that is capable of being implanted within the body of an animal, with that portion of the housing covering the bioreporter container comprising a semi-permeable membrane that permits passage of the analyte from the body of the animal to contact the biosensor, but restricts the bioreporter molecules from diffusing into the body of the animal that contains the implanted device. The bioreporter may be in solution, that is a cell suspension, and entrapped in the container by the semi-permeable membrane, or alternatively the bioreporter may be encapsulated in a selectively permeable polymer matrix that is capable of allowing the selected substance in solution reach the bioreporter. Preferably, the matrix is optically clear.

The apparatus may further comprise a layer of bioresistant/biocompatible material between the substrate and the container, such a layer of silicon nitride. The integrated circuit is preferably a CMOS integrated circuit, and the phototransducer is preferably a photodiode.

5 The integrated circuit may also include a current to frequency converter and/or a digital counter. Additionally, the integrated circuit may also include one or more transmitters. Such transmitters may be wireless, or conventionally wired. In preferred embodiment, the apparatus also includes a drug delivery device capable of receiving transmissions from the transmitter.

10 A further embodiment of the invention is an implantable apparatus for detecting a selected substance in solution, which comprises an integrated circuit including a phototransducer adapted to input an electrical signal into the circuit in response to light, a bioreporter capable of responding to selected substance in solution by emitting light, the reporter adapted to contact the substance; and a transparent, biocompatible, and
15 bioresistant separator positioned between the phototransducer and the bioreporter to enable light emitted from the bioreporter to strike the phototransducer. In a preferred embodiment of the present invention, the selected substance is glucose. The bioreporter may be a mammalian cell that contains a nucleotide sequence that encodes one or more luminescent reporter molecules. Such a nucleotide sequence may comprise one or more
20 *lux* genes. In a preferred embodiment the *lux* genes comprise both *luxCDE* genes and fused *luxAB* genes. In one embodiment, these *lux* genes are derived from *Xenorhabdus luminescens*. The *lux* genes may be regulated by a nucleic acid sequence comprising one or more *cis*-acting glucose response elements. In an illustrative embodiment, the glucose response element may be derived from the β -islets or hepatic L-pyruvate kinase gene. In
25 a highly preferred embodiment the p.LPK.Luc_{FF} plasmid is used to provide one or more glucose response elements and the L-pyruvate kinase promoter to drive the expression of one or more *lux* genes. The cells constituting the bioreporter may be in suspension, entrapped in place on the IC by a semi-permeable membrane. Alternatively the cells constituting the bioreporter may be encapsulated in a polymer matrix affixed to IC. Such
30 a matrix may be permeable to the selected substance in solution.

A further embodiment of the invention concerns an implantable monolithic bioelectronic device for detecting a selected substance in body fluid. This device

generally comprises a biocompatible housing; a bioreporter capable of responding to a selected substance by emitting; and, a sensor capable of generating an electrical signal in response to the reception of the emitted light. Such a device may also include a transparent, bioresistant and biocompatible separator positioned between the bioreporter and the sensor and a semi-permeable membrane positioned in the biocompatible housing so that the selected substance can access the bioreporter.

A standard integrated circuit (IC) is coated with a layer of insulating material such as silicon dioxide or silicon nitride. This process is called passivation and serves to protect the surface of the chip from moisture, contamination, and mechanical damage. BBICs require a second coating that must be biocompatible and bioresistant, must protect the OASIC from chemical stresses, must be optically tuned to efficiently transmit the light from the material under test, must adhere to an oxide coating, must be pin-hole free, and must be able to be patterned in order to form openings over the bonding pads and whatever structures that might be needed to maintain the bioreporter or collect a sample.

The present invention contemplates that the components of the biosensor may be packaged in kit form. Kits may comprise, in suitable container means, one or more bioreporters and an integrated circuit including a phototransducer. Kits may further comprise a drug delivery device.

3.0 BRIEF DESCRIPTION OF THE DRAWINGS

The following drawings form part of the present specification and are included to further demonstrate certain aspects of the present invention. The invention may be better understood by reference to one or more of these drawings in combination with the detailed description of specific embodiments presented herein. Illustrative embodiments of the present invention are depicted in the drawings, with like numerals being used to refer to like and corresponding parts of the various drawings.

FIG. 1 shows a perspective view of one illustrative embodiment of the invention.

FIG. 2 shows a side view of an illustrative embodiment of the present invention.

FIG. 3 shows a block diagram of an illustrative embodiment of the integrated circuit.

FIG. 4A shows a high-quality photodetector that can be made using a standard N-well CMOS process.

FIG. 4B shows two photodetector structures fabricated in a silicon-on-insulator CMOS process: on the left, a lateral PIN detector; on the right, a device similar to left except that the junction is formed with a Schottky junction.

FIG. 5A shows a simple photodiode consisting of a P-diffusion layer, an N-well, and a P-substrate.

FIG. 5B shows a circuit using a large area photodiode for efficient light collection, and a small-area diode in a feedback loop to supply the forward bias current that cancels out the photocurrent.

FIG. 5C shows a circuit using correlated double sampling (CDS) to minimize the effects of low frequency (flicker) amplifier noise as well as time or temperature dependent variations in the amplifier offset voltage.

FIG. 6 shows the current-to-frequency converter architecture of the apparatus.

FIG. 7 shows a prototype BBIC biosensor.

FIG. 8 shows a minimum detectable concentration of toluene as a function of integration time for the prototype BBIC employing the bioreporter *Pseudomonas putida* TVA8.

FIG. 9 shows the schematic representation of a peritoneal glucose biosensor and insulin pump.

FIG. 10A shows a schematic representation of an implantable biosensor containing two separate photodetectors with the bioreporters responding to either an increase or decrease in glucose concentrations.

FIG. 10B shows a side view of biosensor showing silastic covering.

FIG. 10C shows a schematic representaion of the utilization of a selectably permeable membrane to protect bioreporters from the immune response.

4.0 DESCRIPTION OF ILLUSTRATIVE EMBODIMENTS

The luciferase system has been adapted for use in biosensors *in vivo*. In prokaryotes, the *lux* system consists of a luciferase composed of two subunits coded for by the genes *luxA* and *luxB* that oxidize a long chain fatty aldehyde to the corresponding fatty acid resulting in a blue-green light emission at an approximate wavelength of 490 nm (Tu and Mager, 1995). The system also contains a multienzyme fatty acid reductase consisting of three proteins, a reductase encoded by *luxC*, a transferase encoded by *luxD*,

and a synthetase encoded by *luxE* that convert and recycle the fatty acid to the aldehyde substrate. The genes are contained on a single operon, allowing for the cloning of the complete *lux* gene cassette downstream from user-specific promoters for the utilization of bioluminescence to monitor gene expression. The majority of bioluminescent bioreporters consist of Gram-negative organisms engineered to detect and monitor critically important chemical and environmental stressors (Ramanathan *et al.*, 1997, Steinberg *et al.*, 1995). Luciferase fusions in Gram-positive bacteria, as well as in yeast cell lines, are also being successfully performed (Andrew and Roberts, 1993, Srikantha *et al.*, 1996).

Eukaryotic luciferase genes cloned into bacterial reporters include the firefly luciferase (*luc*) producing light near 560 nm and the click beetle luciferase (*lucOR*) emitting light near 595 nm (Cebolla *et al.*, 1995, Hastings, 1996). Eukaryotic bioreporters have been designed to monitor glucose concentrations in rat islet β -cells (Kennedy *et al.*, 1997), steroid activity in HeLa cells (Gagne *et al.*, 1994), ultraviolet light effects in mouse fibroblast cells (Filatov *et al.*, 1996), toxicity effects in human liver cancer cells (Anderson *et al.*, 1995), estrogenic and antiestrogenic compounds in breast cancer cell lines (Demirpence *et al.*, 1995), and erythropoietin gene induction in human hepatoma cell lines (Gupta and Goldwasser, 1996). To date, most eukaryotic bioluminescent reporters require cell destruction and the addition of an exogenous substrate, usually luciferin, to generate a measurable luminescent response.

Green fluorescent protein ("GFP") is also routinely used as a reporter system, with the significant advantage that cells do not require destructive assay techniques to produce colorimetric signals (Hanakam *et al.*, 1996; Grygorczyk *et al.*, 1996; Siegel and Isacoff, 1997; Biondi *et al.*, 1998). However, a substrate must be added to the GFP constructs to first initiate the light response (Prasher, 1995). Humanized GFP cDNA has been developed which is specifically adapted for high-level expression in mammalian cells, especially those of human origin (Zolotukhin 1996). Humanized GFP can be efficiently inserted into mammalian cells using viral vectors (Levy *et al.*, 1996; Gram *et al.*, 1998).

Detection of the bioluminescent signal from the reporter organisms is achieved through the use of optical transducers, including photomultiplier tubes, photodiodes, microchannel plates, photographic films, and charge-coupled devices. Light is collected and transferred to the transducer through lenses, fiber optic cables, or liquid light guides.

However, applications requiring small volumes, remote detection, or multiple parallel sensing necessitate a new type of instrumentation that is small and portable, yet maintains a high degree of sensitivity.

5 4.1 OVERVIEW OF THE SYSTEM

The present invention describes an implantable BBIC that detects selected substances. The bioreporter is a genetically engineered cell line in which the nucleic acid sequence contains a *cis*-activating response element that is responsive to the selected substance. In preferred embodiments, the selected substance is glucose. Exposure of the
10 bioreporter to the selected substances causes the response element to up-regulate a nucleic acid sequence that encodes one or more polypeptides that generate a luminescent response. In a preferred embodiment, the luminescent response is generated by a prokaryotic *lux* system.

The function of the IC portion of the BBIC is to detect, filter, amplify, digitize,
15 and report the bioluminescent signal. In effect, the IC serves as a complete laboratory instrument-on-a-chip: a microluminometer.

Silicon-based ICs can detect optical signals in the near ultraviolet, visible, and near infrared regions using the PN junctions normally used to form transistors (Simpson *et al.*, 1999a). Using an n-well/p-substrate photodiode in a 0.5- μ m bulk CMOS IC process, an
20 ~66% quantum efficiency has been measured at the 490-nm bioluminescent wavelength (Simpson *et al.*, 1999b). A variety of signal-processing schemes can be employed. However, counting the pulses from a current-to-frequency converter circuit forms a long time-constant integrator and is the causal portion of the matched filter for a low-level bioluminescent signal in white noise. Using the photodiode mentioned above with this
25 signal-processing scheme, an rms noise level of 175 electrons/second was measured for a 13-minute integration time, corresponding to a detection limit of ~500 photons/second (Simpson *et al.*, 1999b).

A prototype BBIC was constructed by placing the toluene sensitive bioreporter, *P. putida* TVA8, above a custom integrated microluminometer. FIG. 6 shows the prototype
30 BBIC (including the bioreporter enclosure) as used in the characterization studies (Simpson *et al.*, 1998b; Simpson *et al.*, 1998c; Simpson *et al.*, 1998d).

With no luminescent signal coming from the cells, multiple measurements were taken with the integration time set to 1-minute. Leakage currents produced a signal of ~6 counts/minute with a standard deviation (σ) of 0.22 counts/minute. As expected, the σ decreased with the square root of the integration time. Longer integration times were produced off-line by summing 1-minute measurements.

Bioluminescence was induced in the BBIC cells and a control sample of cells by exposure to toluene vapor. From the control sample measurements, we estimate that the toluene concentration was no more than 1 ppm. A signal of 12 counts/minute (6 counts/minute above background) was measured. From previous measurements, *P. putida* TVA8 is known to have a linear response to toluene concentration until saturating when the concentration reaches a level of approximately 10 ppm. The minimum detectable toluene concentration for this BBIC as a function of integration time is shown in FIG. 8. In general, the minimum detectable concentration is also a function of the number of bioreporter cells and the area of the photodiode.

A naphthalene-sensitive BBIC was produced using the microluminometer described above and the bioreporter *P. fluorescens* 5RL. Using the same experimental procedure described above, this BBIC was exposed to naphthalene vapor with a concentration of approximately 10 ppm. A signal of 240 counts/minute was recorded.

To eliminate the need for the addition of exogenous substrate, cells must themselves supply the appropriate substrate for the luciferase. In the bacterial system the substrate is generated by a fatty acid reductase complex coded for by the *luxCDE* genes. This enzyme complex reduces short chain fatty acids to the corresponding aldehyde. The luciferase then oxidizes the aldehyde to the corresponding fatty acid. The preferred fatty acid for this reaction is myristic acid, which is present in eukaryotic organisms (Rudnick *et al.*, 1993). Myristic acid is usually involved in the myristoylation of the amino terminus that is associated with membrane attachment (Borgese *et al.*, 1996, Brand *et al.*, 1996).

In a preferred embodiment, the bioreporter for glucose monitoring will be a mammalian bioluminescent reporter cell line that has been genetically engineered to express luminescence in response to glucose concentrations on a continuous basis, without the need for cell destruction and exogenous substrate addition. Current methodologies using mammalian bioluminescent reporter cells require cell lysis and addition of an

exogenous substrate to generate a measurable response. Consequently, these cells cannot serve as continuous on-line monitoring devices. In a preferred embodiment, this new cell line is constructed with a bioluminescent reporter utilizing the *luxAB* and *luxCDE* genes from *X. luminescens* incorporated into a plasmid-based system designated p.LPK.Luc_{FF} which contains a eukaryotic *luc* gene able to respond to glucose concentrations. Replacement of the *luc* gene with the *luxAB* gene will allow for bioluminescence measurements to occur in real-time with glucose concentrations, negating the requirement for cell destruction and substrate addition.

To form an implantable, glucose-monitoring BBIC, the bioreporters may be entrapped in a container behind a semi-permeable membrane that keeps them in place over the IC photodetector. Alternatively the bioreporter may be encased in a polymer matrix. The BBIC is enclosed in a biocompatible housing with a semi-permeable membrane covering the bioreporter region. This membrane allows glucose to pass to the bioreporters, yet stops the passage of larger molecules that could interfere with the glucose measurement. When the glucose reaches the bioreporter, it is metabolized and the cells emit visible light. The IC detects this light, amplifies and filters this signal, and then reports this measurement. This measurement could be reported to the patient (e.g., to a wristwatch receiver) or could be reported to an insulin pump in a closed-loop system that functions much like the pancreas.

FIG. 1 shows a perspective view of the present invention. Glucose **10** that is being detected enters the BBIC **11** through the semi-permeable membrane **12** that covers the bioreporter.

FIG 2 shows a side view of the present invention. The BBIC is enclosed in a biocompatible housing **20** with a semi-permeable membrane **21** covering the bioreporter held in a container **22**. The cells constituting the bioreporter may be in suspension or encapsulated in a polymer matrix. The bioreporter is separated from a photodetector **23** by a protective coating **24**. A single substance **25** contains the photodetector as well as additional circuits **26** that process and transmits the signal.

FIG. 3 shows a block diagram of one embodiment of the integrated circuit ("IC"). The photodetector is a photodiode **33** connected to a current to frequency converter **30**. The photodiode responds to light by sinking a current. The current is converted to a series of pulses that are accumulated in a digital counter **31**. The number of counts in the

counter in a fixed amount of time is directly proportional to the amount of light collected by the photodiode, which is directly proportional to the concentration of glucose. Digital processing circuitry in the digital counter would determine the appropriate next step for an insulin pump based on the measured glucose levels. The measured concentration or next instruction for the insulin pump could be reported *via* the wireless transmitter 32. All these circuits (photodiode, signal processing, and wireless transmission) can be fabricated on one IC.

FIG. 4 shows the bioreporter being supplied with water and nutrients. A fluid and nutrient reservoir 141 is connected to a microfluidic pump 142 so that nutrient and fluid 144 may flow through the polymer matrix 143 enclosing the bioreporter. Each of these components can be constructed on a single substrate 140.

FIG. 5A shows a high-quality photodetector made using a standard N-well CMOS process. The photodetector consists of two reverse biased diodes in parallel. The top diode is formed between the P+ active layer 45 and the N-well 46, and the bottom diode is formed between the N-well 46 and the P-substrate 47. The top diode has good short wavelength light sensitivity (400 – 550 nm), while the bottom diode provides good long wavelength sensitivity (500 – 1100 nm). Thus, the complete diode is sensitive over the range from 400 to 1100 nm. The luminescent compound under test 41 is separated from the photodetector by a layer 40 of Si₃N₄ and a layer 42 of SiO₂.

FIG. 10A, **FIG. 10B**, and **FIG. 10C** show schematic representations of an implantable biosensor containing two separate photodetectors with the bioreporters responding to either an increase or decrease in glucose concentrations.

FIG. 10B shows a side view of biosensor showing silastic covering.

FIG. 10C shows a schematic representaion of the utilization of a selectably permeable membrane to protect bioreporters from the immune response.

4.2 PHOTODETECTOR

The first element in the micro-luminometer signal processing chain is the photodetector. The key requirements of the photodetector are:

- Sensitivity to wavelength of light emitted by the bioluminescent or chemiluminescent compound under test;

- Low background signal (*i.e.* leakage current) due to parasitic reverse biased diodes;
- Appropriate coating to prevent the materials in the semiconductor devices from interfering with the bioluminescent or chemiluminescent process under study and to prevent the process under study from degrading the performance of the micro-luminometer; and,
- Compatibility with the fabrication process used to create the micro-luminometer circuitry.

5

10

Two photodetector configurations that satisfy these requirements are described below. It should be understood, however, that alternative methods of constructing such a photodetector can be used by one skilled in the art without departing from the spirit and scope of the invention as defined in the claims.

15

20

In the first embodiment, the photodetector is fabricated in a standard N-well CMOS process. Shown in **FIG. 5A**, this detector is formed by connecting the PN junction between the PMOS active region and the N-well in parallel with the PN junction between the N-well and the P-type substrate. The resulting detector is sensitive to light between approximately 400 nm and approximately 1100 nm, a range that encompasses the 450 to 600 nm emission range of most commonly used bioluminescent and chemiluminescent compounds or organisms. In order to meet the requirement that the device have a low background signal, the device is operated with a zero bias, setting the operating voltage of the diode equal to the substrate voltage. The photodiode coating may be formed with a deposited silicon nitride layer or other material compatible with semiconductor processing techniques.

25

30

In the second photodetector embodiment, the detector is fabricated in a silicon-on-insulator (SOI) CMOS process. The internal leakage current in an SOI process is two to three orders of magnitude lower than in standard CMOS due to the presence of a buried oxide insulating layer between the active layer and the substrate. Two photodetector structures are envisioned in the SOI process. The first structure, shown on the left of **FIG. 5B**, consists of a lateral PIN detector where the P-layer is formed by the P+ contact layer, the I (intrinsic) region is formed by the lightly doped active layer, and the N region is formed by the N+ contact layer of the SOI CMOS process. The spectral sensitivity of this

lateral detector is set by the thickness of the active layer, which may be tuned for specific bioluminescent and chemiluminescent compounds.

The second structure, shown on the right side of **FIG. 3B**, is similar to the first except that the junction is formed with a Schottky junction between a deposited cobalt silicide (CoSi_2) or other appropriate material layer and the lightly doped active layer.

The inventors contemplate that other photodetector configurations may be envisioned in silicon or other semiconductor processes meeting the criteria set forth above.

4.3 LOW NOISE ELECTRONICS

The low noise electronics are the second element in the micro-luminometer signal processing chain. The requirements for the low noise electronics are:

- Sensitivity to very low signal levels provided by the photodetector;
- Immunity to or compensation for electronic noise in the signal processing chain;
- Minimum sensitivity to variations in temperature;
- Minimum sensitivity to changes in power supply voltages (for battery powered applications);
- For some applications the electronics must have sufficient linearity and dynamic range to accurately record the detected signal level; and,
- In other applications the electronics must simply detect the presence of a signal even in the presence of electronic and environmental noise.

Three embodiments that satisfy these requirements are described below. It should be understood, however, that alternative methods of detecting small signals while satisfying these requirements may be used without departing from the spirit and scope of the invention as defined in the claims.

FIG. 6A schematically shows the first approach to the detection of very small signals. This device uses a P-diffusion/N-well photodiode, a structure compatible with standard CMOS IC processes, in the open circuit mode with a read-out amplifier (fabricated on the same IC with the photodiode). The luminescent signal generates electron-hole pairs in the P-diffusion and the N-well. The photo-generated electrons in the P-diffusion are injected into the N-well, while the photo-generated holes in the N-well

are injected into the P-diffusion. The N-well is tied to ground potential so that no charge builds up in this region. However, since the P-diffusion is only attached to the input impedance of a CMOS amplifier (which approaches infinity at low frequencies), a positive charge collects in this region. Thus, the voltage on the P-diffusion node begins to rise.

As the P-diffusion voltage begins to rise, the P-diffusion/N-well photodiode becomes forward biased, thereby producing a current in a direction opposite to the photo-generated current. The system reaches steady state when the voltage on the P-diffusion node creates a forward bias current exactly equal in magnitude (but opposite in polarity) to the photocurrent. If this PN junction has no deviations from the ideal diode equation, then the output voltage is given by the following equation:

$$V_{out} = V_t \ln(I_p / (A I_s) + 1), \quad (\text{Eq. 1})$$

where V_t is the thermal voltage (approximately 26 mV at room temperature), I_p is the photo-current, A is the cross-sectional area of this PN junction, and I_s is the reverse saturation current for a PN junction with unit cross-sectional area. The value of I_s depends greatly on the IC process and material parameters.

Two major error currents are present in PN junctions operating at low current density: recombination current and generation current. Except at very low temperatures, free carriers are randomly created in the PN junction space charge region. Since this region has a high field, these thermally excited carriers are immediately swept across the junction and form a current component (generation current) in the same direction as the photocurrent. Carriers crossing the space-charge region also have a finite chance of recombining. This creates another current component (recombination current) in the opposite direction of the photocurrent. Therefore, taking into account these error currents, Eq. 1 becomes:

$$V_{out} = V_t \ln((I_p + I_g - I_r) / (A I_s) + 1). \quad (\text{Eq. 2})$$

This output voltage is a function of parameters that are generally beyond the inventors' control. However, the inventors do have control over the junction area, A . Unfortunately, to make the inventors' output signal larger, the inventors want a small A , while the inventors want a large A for a high quantum efficiency (QE).

FIG. 6B shows a second microluminometer embodiment that satisfies both of these needs. This circuit uses a large area photodiode for efficient light collection, but uses a small-area diode in a feedback loop to supply the forward bias current that cancels out the photocurrent. Once again, the amplifier and feedback diodes are fabricated on the same IC as the photodiode. For this circuit:

$$V_{out} = 3 V_t \ln((I_p + I_g - I_r) / (A_{fb} I_s) + 1), \quad (\text{Eq. 3})$$

where A_{fb} is the small cross-sectional area of the feedback diode. More than one diode is used in the feedback path to make the output signal large compared to the DC offset of any subsequent amplifier stages. This technique allows efficient collection of the light with a large-area photodiode, yet produces a large output voltage because of the small-area diodes in the feedback path.

The feedback circuit of **FIG. 6B** maintains the photodiode at zero bias. With no applied potential, the recombination and generation currents should cancel. Eq. 3 becomes:

$$V_{out} = 3 V_t \ln((I_p / (A_{fb} I_s)) + 1) \quad (\text{Eq. 4})$$

if the smaller recombination and generation currents in the smaller feedback diodes are neglected.

The principal advantages of the second micro-luminometer embodiment shown in **FIG. 6B** include:

- The SNR is totally determined by the photodiode; noise from the small diode and amplifier are negligible;
- Diodes can be added in the feedback path until the signal level at the output of the amplifier is significant compared to offset voltages (and offset voltage drift) of subsequent stages;
- This method is completely compatible with standard CMOS processes with no additional masks, materials, or fabrication steps;
- This detection scheme can be fabricated on the same IC with analog and digital signal processing circuits and RF communication circuits; and,
- Measurement can be made without power applied to the circuit. Power must be applied before the measurement can be read, but the measurement can be obtained with no power.

A third microluminometer implementation shown in FIG. 6C uses correlated double sampling (CDS) to minimize the effects of low frequency (flicker) amplifier noise as well as time or temperature dependent variations in the amplifier offset voltage. As shown in FIG. 6C, a photodiode with capacitance C_d and noise power spectral density S_i is connected to an integrating preamplifier with feedback capacitance C_f and input noise power spectral density S_v through a set of switches that are controlled by the logical level of a flip-flop output. When the flip-flop output is low, the switches are positioned so that the photocurrent flows out of the preamplifier, causing the output voltage of the integrator to increase. When the low-pass filtered integrator output voltage exceeds a threshold, V_{HI} , the upper comparator "fires" setting the flip-flop and causing its output to go high. The detector switches change positions, causing current to flow into the integrating amplifier, which in turn causes the amplifier output voltage to decrease. When the integrator output goes below a second threshold, V_{LO} , the lower comparator "fires" resetting the flip-flop and causing the output to go low again. The process repeats itself as long as a photocurrent is present.

The average period of the output pulse, Δt , is given by the following equation:

$$\Delta t = \frac{2C_f(V_{HI} - V_{LO})}{I_p}, \quad (\text{Eq. 5})$$

where V_{HI} and V_{LO} are the threshold voltages of the comparators and I_p is the diode photocurrent. Two noise sources contribute to error in the measured value of Δt . S_i is the input noise current power spectral density associated primarily with the photodiode, and S_v is the input noise voltage power spectral density associated primarily with the preamplifier. The diode noise is given by the equation:

$$S_i = 2q(2I_s + I_p) \left(\frac{A^2}{\text{Hz}} \right), \quad (\text{Eq. 6})$$

where I_s is the photodiode reverse saturation current and I_p is the photocurrent. As the photocurrent approaches zero, the noise power spectral density approaches a finite value of $4qI_s$, A^2/Hz . The noise voltage S_v of the preamplifier is determined by its design and has units of V^2/Hz .

The transfer function from the point where the diode noise is introduced to the output of the integrator is given approximately by the equation:

$$H_i(\omega) \approx \left(\frac{1}{sC_f} \right) \left(\frac{\omega_1}{s + \omega_1} \right), \quad (\text{Eq. 7})$$

where ω_1 is the corner frequency of the integrating amplifier and $s = j\omega$. Ignoring for the moment the effect of the switches, the transfer function from the point where the amplifier noise is introduced to the output of the integrator is given approximately by the equation:

$$5 \quad H_v(\omega) \approx \left(\frac{C_f + C_d}{C_f} \right) \left(\frac{\omega_1}{s + \omega_1} \right). \quad (\text{Eq. 8})$$

The switches perform a correlated double sampling function that attenuates the noise that appears below the switching frequency of the output pulse string. The transfer function of a correlated double sampling circuit is approximated to first order by the equation:

$$10 \quad H(\omega) \approx \left(\frac{s}{s + 2/\Delta t} \right), \quad (\text{Eq. 9})$$

where Δt is the average period of the output pulse string. Thus, taking into account the switches, the transfer function from the point where the amplifier noise is introduced to the output of the integrator is approximately given by the equation:

$$H_v(\omega) \approx \left(\frac{C_f + C_d}{C_f} \right) \left(\frac{\omega_1}{s + \omega_1} \right) \left(\frac{s}{s + 2/\Delta t} \right). \quad (\text{Eq. 10})$$

15 This is an important result because the effective zero introduced in the noise voltage transfer function reduces the effect of the flicker noise of the amplifier. This is particularly useful in CMOS implementations of the micro-luminometer where flicker noise can have a dominant effect.

The mean squared output noise at the output of the integrator is given by the
20 equation:

$$v_n^2 = \int_{-\infty}^{\infty} S_v(H_v * H_v) + S_i(H_i * H_i) d\omega, \quad (\text{Eq. 11})$$

and the RMS noise voltage is then given by the equation:

$$\sigma_v = \sqrt{v_n^2}. \quad (\text{Eq. 12})$$

The RMS error in the measured period is determined by the slope of the integrated signal and the noise at the output of the integrator following the relationship:

$$\sigma_t = \frac{\sigma_v}{dv/dt} \quad (\text{Eq. 13})$$

or, approximately, by the equation:

$$5 \quad \sigma_t \approx \frac{\sigma_v}{(V_{HI} - V_{LO}) \Delta t} \quad (\text{Eq. 14})$$

The error in measuring Δt may be reduced by collecting many output pulses and obtaining an average period. The error in the measured average pulse period improves proportionately to the square root of the number of pulses collected, such that

$$\bar{\sigma}_t \approx \frac{\sigma_v}{(V_{HI} - V_{LO}) \Delta t} \frac{1}{\sqrt{N}} \quad (\text{Eq. 15})$$

10 or

$$\bar{\sigma}_t \approx \frac{\sigma_v}{(V_{HI} - V_{LO}) \Delta t} \sqrt{\frac{t_{meas}}{\Delta t}} \quad (\text{Eq. 16})$$

where t_{meas} is the total measurement time.

Thus, implementation of the micro-luminometer has the following advantages:

- The low frequency "flicker" noise of the amplifier is reduced by a correlated double sampling process; and,
- Ideally, the accuracy of the measured photocurrent may be improved without limit by acquiring data for increasing periods of time.

Of course, practical limitations imposed by the lifetime and stability of the signals produced by the luminescent compound under test will ultimately determine the resolution of this implementation.

4.4 READ-OUT ELECTRONICS

Several methods of communicating data from the BBIC to external receivers or *in vivo* drug delivery systems are envisaged. In a preferred embodiment the communication

method is an on-chip wireless communication system that reports the level of the photocurrent to computing circuitry contained within *in vivo* drug delivery system or an external receiver. In a closed-loop system, this computing circuitry would determine the amount of drug to be delivered by the *in vivo* drug delivery system. If an external receiver were used, the data from the BBIC along with the user inputs would be used to determine the amount of drug to be administered. The external receiver may include wireless transmission circuitry for communication with the *in vivo* drug delivery system or the drugs may be administered manually. Other methods of communicating BBIC data include;

- 10 • Generation of a DC voltage level proportional to the photocurrent with a hardwire connection to an *in vivo* drug delivery system;
- Generation of a DC current level proportional to the photocurrent with a hardwire connection to an *in vivo* drug delivery system;
- Generation of a logical pulse string whose rate is proportional to the photocurrent with a hardwire connection to an *in vivo* drug delivery system;
- 15 • On-chip implementation of an analog to digital converter that reports a numerical value proportional to the photocurrent with a hardwire connection to an *in vivo* drug delivery system;
- On-chip implementation of a serial or parallel communications port that reports a number proportional to the photocurrent with a hardwire connection to an *in vivo* drug delivery system;
- 20 • Generation of a logical flag when the photocurrent exceeds a predefined level with a hardwire connection to an *in vivo* drug delivery system; and,
- Generation of a radio-frequency signal or beacon when the photocurrent exceeds a predefined level.
- 25

Wireless communication *in vivo* may be limited by signal attenuation by body fluids, tissues, and health-related limits on RF signal levels. This may require the BBIC and *in vivo* drug delivery system to be closely spaced, which may not be the optimum configuration for all cases. In such cases, the BBIC could communicate to an external receiver located *ex vivo* but closer to the BBIC. This receiver could be connected

30

(hardwired or wirelessly) to a transmitter located *ex vivo* but closer to the *in vivo* drug delivery system.

Numerous algorithms are envisioned for controlling an *in vivo* drug delivery system with a BBIC. These include, but are not limited to

- 5 • a simple look-up table that administers a prescribed drug level that is determined only by a single BBIC data point;
- a simple look-up table that administers a prescribed drug level when a predetermined number of data points exceed a preset threshold;
- an algorithm that determines drug dosage by rate of increase or decrease of
10 BBIC signal
- an algorithm that determines drug dosage by matching BBIC data points to data point patterns stored in memory
- learning algorithms that use BBIC data point history and user inputs to predict
15 correct drug dosage to achieve desired results

15 Some of these algorithms may require two-way communication between the BBIC and *in vivo* drug delivery system. In this case, a receiver would be included on the BBIC.

4.5 BIOCOMPATIBLE HOUSING AND SEMI-PERMEABLE MEMBRANE

20 The BBIC is enclosed in a biocompatible housing with a semi-permeable membrane covering the bioreporter region. The preparation of biocompatible coverings for implants and prosthetic devices so as to minimize capsule formation and physiological rejection has been an area of extensive investigation. For example, U. S. Patent 5,370,684 and U. S. Patent 5,387,247 (each specifically incorporated herein by reference in its entirety), describe the application of a thin biocompatible carbon film to prosthetic
25 devices. A biocompatible implant material comprising a three-dimensionally woven or knitted fabric of organic fibers is disclosed in U. S. Patent 5,711,960, specifically included herein in its entirety. Other coverings for implants constructed to present a biocompatible surface to the body are described in U. S. Patent 5,653,755, U. S. Patent 5,779,734, and U. S. Patent 5,814,091 (each specifically incorporated herein by reference in its entirety). In
30 addition, collagen coating and albumin coating have been shown to improve the biocompatibility of implants and prosthetic devices (Marios *et al.*, 1996; Ksander, 1988).

The present invention contemplates the use of any suitable biocompatible material to either coat or form the housing.

A semi-permeable membrane comprises that part of the BBIC housing that covers the bioreporter and entraps them on the integrated circuit. This membrane allows the selected substance, such as glucose, to pass to the bioreporter, yet prevents the passage of larger molecules. Membranes designed for use with glucose-oxidase based biosensors may also be used in the preferred embodiments of the present invention. Membranes investigated and designed for use with glucose-oxidase based biosensors include, but are not limited to: polytetrafluoroethylene membranes (Vaidya and Wilkins, 1993); perfluorinated ionomer membranes (Moussy *et al.*, 1994); charged and uncharged polycarbonate membranes (Vadiya and Wilkins 1994); and cellulose acetate membranes (Wang and Yuan, 1995; Sternberg *et al.*, 1988). In addition, other membranes have been developed for the use transplantation of islets or other cells bioengineered to produce insulin. The membranes must be permeable to glucose and other metabolites while exclude elements of the host immune system. Such membranes may be adapted for use with the present invention and include, but are not limited to: asymmetric poly(vinyl alcohol) membranes (Young *et al.*, 1996); poly(L-lysine) membranes (Tziampazis and Sambanis, 1995); polyurethane (Zondervan *et al.*, 1992); nucleopore membranes (Ohgawara *et al.*, 1998) ; and agarose gel (Taniguchi *et al.*, 1997). Biocompatible semi-permeable membranes for encapsulation of cells to form an artificial organ are described in U. S. Patent 5,795,790 and U. S. Patent 5,620,883 (each specifically incorporated herein by reference in its entirety). A biocompatible semi-permeable segmented block polyurethane copolymer membrane and its use for permeating molecules of predetermined molecular weight range are disclosed in U.S. Patent No. 5,428,123, (specifically incorporated herein by reference in its entirety). The present invention contemplates the use of any suitable semi-permeable membrane that allows the selected substance access to the bioreporter yet prevents the passage of larger molecules.

4.6 DRUG DELIVERY DEVICES

Numerous drug delivery devices, implantable and external, have been previously described which can be controlled by radio telemetry. For example, U. S. Patent 4,944,659 (specifically incorporated herein by reference in its entirety), describes an

implantable piezoelectric pump for drug delivery in ambulatory patients. U. S. Patent 5,474,552, specifically included herein in its entirety, describes an implantable pump for use in conjunction with a glucose sensor that can deliver multiple active agents, such as glucose, glucagon, or insulin as required. Separate pumps may be used for delivering each of the agents or a single pump that is switchable between them may be used. U. S. Patent 5,569,186, specifically included herein in its entirety, describes a closed loop infusion pump system controlled by a glucose sensor. U. S. Patent 4,637,391, specifically included herein in its entirety, describes a remote controlled implantable micropump for delivery of pharmaceutical agents. The use of external drug delivery systems is contemplated in other embodiments of the present invention. For example, U. S. Patent 5,800,420, specifically included herein in its entirety, discloses a pump positioned topically against the skin surface that delivers a liquid drug, such as insulin, *via* a hollow delivery needle extending into the dermis. In other embodiments of the present invention, the drug delivery system may be interfaced with the biosensor device and controlled directly, as opposed to remote telemetry control, from the BBIC.

The pump delivery systems described above are examples to facilitate the use of the present invention. Drug delivery devices other than pump systems are also contemplated by the present invention. For example, U. S. Patent 5,421,816, specifically included herein in its entirety, describes an ultrasonic transdermal drug delivery system. Ultrasonic energy is used to release a stored drug and forcibly move the drug through the skin of an organism into the blood stream. Thus the invention contemplates the use of any suitable drug delivery system that can be controlled by the BBIC glucose monitor. The factors dictating the choice of such a drug delivery system and its use with the BBIC glucose monitor use will be known to those of skill in the art in light of the present disclosure.

4.7 BIOLUMINESCENT BIOREPORTERS

In a preferred embodiment of the invention, the bioreporter for glucose monitoring will be a mammalian bioluminescent reporter cell line that has been genetically engineered to express luminescence in response to glucose concentrations on a continuous basis. An implantable bioluminescent sensor requires a bioluminescent reporter that can function without the exogenous addition of substrate for the luciferase reaction. Current

eukaryotic luciferase systems used in molecular biology require the addition of exogenous substrate because of the complex nature for the production of eukaryotic luciferins. Cells must be either permeabilized or lysed and then treated with an assay solution containing luciferin. Thus current eukaryotic luciferases systems are not preferred candidates for on-

5 line monitoring.

The requirement for the addition of exogenous substrate can be obviated by the use of bacterial *lux* genes. In a preferred embodiment of the present invention the *lux* genes of *X. luminescens*, *luxAB* and *luxCDE*, are used as the bioluminescent reporter system. The *X. luminescens luxAB* gene encodes the α - and β -subunits of a luciferase

10 enzyme that exhibits greatest thermostability at 37°C, while other bacterial luciferases lose significant activity above 30°C. The *luxCDE* genes are required to eliminate the need for the addition of exogenous substrate. The aldehyde substrate of the luciferase encoded by the *luxAB* genes is generated by a fatty acid reductase complex coded for by the *luxCDE* genes. The preferred fatty acid for this reaction is myristic acid, which is present

15 in eukaryotic organisms (Rudnick *et al.*, 1993), and thus eukaryotic cells are suitable host cells for this reporter. The enzyme complex reduces the fatty acid to the corresponding aldehyde. The luciferase then oxidizes the aldehyde to back to the fatty acid.

Other bioluminescence nucleic-acid segments may include the *lux* genes of *Vibrio fischerii*, *luxCDABE*, or luciferases from other organisms capable of bioluminescence that can be adapted so not as to require the addition of exogenous substrate. In other

20 embodiments of the invention, nucleic acid segment encodes green fluorescent protein of *Aequorea victoria* or *Renilla reniformis*.

4.8 RECOMBINANT VECTORS EXPRESSING BIOLUMINESCENCE GENES

One important embodiment of the invention is a recombinant vector that

25 comprises one or more nucleic-acid segments encoding one or more bioluminescence polypeptides. Such a vector may be transferred to and replicated in a eukaryotic or prokaryotic host.

It is contemplated that the coding DNA segment will be under the control of a

30 recombinant, or heterologous promoter. As used herein, a recombinant or heterologous promoter is intended to refer to a promoter that is not normally associated with a DNA segment encoding a crystal protein or peptide in its natural environment. Naturally, it will

be important to employ a promoter that effectively directs the expression of the DNA segment in the cell type, organism, or even animal, chosen for expression. The use of promoter and cell type combinations for protein expression is generally known to those of skill in the art of molecular biology (*see e.g.*, Sambrook *et al.*, 1989). In a preferred embodiment of this, such promoters are directed by *cis*-acting glucose response elements. In one preferred embodiment, the glucose response element is the L4 box which directs the L-pyruvate kinase ("L-PK") promoter in liver and islet β -cells. The L4 box consists of a tandem repeat of non-canonical E-boxes (Kennedy *et al.*, 1997). Glucose enhances the hepatic and pancreatic β -cell by modifying the transactivating capacity of upstream stimulatory factors ("USF") bound to the L4 box (Kennedy *et al.*, 1997; Doiron *et al.*, 1996).

The exact mechanism by which glucose controls the transactivational capacity of USF proteins is unclear. One possibility is the reversible phosphorylation of USF proteins. Glucose may alter the phosphorylation status through the pentose phosphate shunt *via* xylose 5-phosphate (Dorion *et al.*, 1996). An alternative mechanism is *via* the intracellular concentration of glucose 6-phosphate (Foufelle *et al.*, 1992). Other glucose metabolites may also be implicated. Phosphorylated glucose metabolites include, but are not limited to, fructose 6-phosphate, 6-phosphogluconic acid, 6-phosphoglucono- δ -lactone, ribulose 5-phosphate, ribose 5-phosphate, erythrose 4-phosphate, sedoheptulose 7-phosphate, glyceraldehyde 3-phosphate and dihydroxyacetone phosphate. Non-phosphorylated glucose metabolites include, but are not limited to, citric acid, *cis*-aconitic acid, *threo*-isocitric acid, succinic acid, fumaric acid, malic acid, oxaloacetic acid, pyruvic acid and lactic acid.

Another glucose response element, similar in arrangement to the L-PK gene L4 box, is the regulatory sequence involved in the transcriptional induction of the rat S14 gene (Shih *et al.*, 1995). Other glucose response elements that have been described include, but are not limited to, the hepatic 6-phosphofructo-2-kinase gene (Dupriez and Rousseau, 1997), the β -islets insulin gene (German and Wang, 1994), the mesangial transforming growth factor-beta gene (Hoffman *et al.*, 1998), and the gene for acetyl-coenzyme-A carboxylase (Girard *et al.*, 1997). The present invention contemplates the use any glucose response element that can effectively direct a promoter or otherwise control the expression of the reporter protein in response to glucose.

In a preferred embodiment, the recombinant vector comprises a nucleic-acid segment encoding one or more bioluminescence polypeptides. Highly preferred nucleic-acid segments are the *lux* genes of *X. luminescens luxAB* and *luxCDE*. Bacterial luciferases may have to be modified to optimize expression in eukaryotic cells. Almashanu *et al.* (1990) fused the *luxAB* genes from *V. harveyi* by removal of the TAA stop codon from *luxA*, the intervening region between the two genes, and the initial methionine from *luxB* without disrupting the reading frame. The fusion was successfully expressed in *Saccharomyces cerevisiae* and *Drosophila melanogaster*. The same strategy was used with *luxAB* from *X. luminescens*. The resultant construct has been sequenced to verify the genetic changes to generate the fusion and they were confirmed. The sequence of the fusion region is as follows:

5'-tacctagggagaaagagaatg-3' (SEQ ID NO:7)

(end of *luxA* underlined)

(start of *luxB* underlined)

The fusion successfully expresses fused protein in *E.coli* and has been successfully cloned into the mammalian vector as described in Section 5.1.2.

In a further embodiment, the inventors contemplate a recombinant vector comprising a nucleic-acid segment encoding one or more enzymes that are capable of producing a reaction that yields a luminescent product or a product that can be directly converted to a luminescent signal. For example, substrates of the commonly used β -galactosidase and alkaline phosphates enzymes are commercially available that are luminescent (chemiluminescence) when converted by the respective enzyme.

In another important embodiment, the biosensor comprises at least a first transformed host cell that expresses one or more of recombinant expression vectors. The host cell may be either prokaryotic or eukaryotic. In a preferred embodiment, the host cell is a mammalian cell. Host cells may include stem cells, β -islets cells or hepatocyte cells. In a preferred embodiment the host cells are homologous cells, *i.e.* cells taken from the patient that are cultured, genetically engineered and then incorporated in the BBIC. Particularly preferred host cells are those which express the nucleic-acid segment or segments comprising the recombinant vector which encode the *lux* genes of *X. luminescens*, *luxAB* and *luxCDE*. These sequences are particularly preferred because the transcribed proteins of the *X. luminescens lux* system have the ability to function at 37°C (ambient human body temperature).

A wide variety of ways are available for introducing a nucleic-acid segment expressing a polypeptide able to provide bioluminescence or chemiluminescence into the microorganism host under conditions that allow for stable maintenance and expression of the gene. One can provide for DNA constructs which include the transcriptional and translational regulatory signals for expression of the nucleic-acid segment, the nucleic-acid segment under their regulatory control and a DNA sequence homologous with a sequence in the host organism, whereby integration will occur or a replication system which is functional in the host, whereby integration or stable maintenance will occur or both.

The transcriptional initiation signals will include a promoter and a transcriptional initiation start site. In preferred instances, it may be desirable to provide for regulative expression of the nucleic-acid segment able to provide bioluminescence or chemiluminescence, where expression of the nucleic-acid segment will only occur after release into the proper environment. This can be achieved with operators or a region binding to an activator or enhancers, which are capable of induction upon a change in the physical or chemical environment of the microorganisms. For translational initiation, a ribosomal binding site and an initiation codon will be present.

Various manipulations may be employed for enhancing the expression of the messenger RNA, particularly by using an active promoter, as well as by employing sequences, which enhance the stability of the messenger RNA. The transcriptional and translational termination region will involve stop codon or codons, a terminator region, and optionally, a polyadenylation signal (when used in an Eukaryotic system).

In the direction of transcription, namely in the 5' to 3' direction of the coding or sense sequence, the construct will involve the transcriptional regulatory region, if any, and the promoter, where the regulatory region may be either 5' or 3' of the promoter, the ribosomal binding site, the initiation codon, the structural gene having an open reading frame in phase with the initiation codon, the stop codon or codons, the polyadenylation signal sequence, if any, and the terminator region. This sequence as a double strand may be used by itself for transformation of a microorganism host, but will usually be included with a DNA sequence involving a marker, where the second DNA sequence may be joined to the expression construct during introduction of the DNA into the host.

By "marker" the inventors refer to a structural gene that provides for selection of those hosts that have been modified or transformed. The marker will normally provide for selective advantage, for example, providing for biocide resistance (*e.g.*, resistance to antibiotics or heavy metals); complementation, so as to provide prototrophy to an auxotrophic host and the like. One or more markers may be employed in the development of the constructs, as well as for modifying the host.

Where no functional replication system is present, the construct will also include a sequence of at least 50 basepairs (bp), preferably at least about 100 bp, more preferably at least about 1000 bp, and usually not more than about 2000 bp of a sequence homologous with a sequence in the host. In this way, the probability of legitimate recombination is enhanced, so that the gene will be integrated into the host and stably maintained by the host. Desirably, the nucleic-acid segment able to provide bioluminescence or chemiluminescence will be in close proximity to the gene providing for complementation as well as the gene providing for the competitive advantage. Therefore, in the event that the nucleic-acid segment able to provide bioluminescence or chemiluminescence is lost, the resulting organism will be likely to also have lost the complementing gene, and the gene providing for the competitive advantage, or both.

A large number of transcriptional regulatory regions are available from a wide variety of microorganism hosts, such as bacteria, bacteriophage, cyanobacteria, algae, fungi, and the like. Various transcriptional regulatory regions include the regions associated with the *trp* gene, *lac* gene, *gal* gene, the λ_L and λ_R promoters, the *tac* promoter. See for example, U. S. Patent 4,332,898; U. S. Patent 4,342,832; and U. S. Patent 4,356,270 (each specifically incorporated herein by reference in its entirety). The termination region may be the termination region normally associated with the transcriptional initiation region or a different transcriptional initiation region, so long as the two regions are compatible and functional in the host. In a preferred embodiment of the present invention, a fragment of the L-pyruvate kinase gene is used that contains the L-PK promoter and the L4 box glucose responsive elements as described by Kennedy *et al.* (1997). In a highly preferred embodiment, the p.LPK.Luc_{FF} plasmid is used (Kennedy *et al.*, 1997), with the exception that the *luc* gene coding for the firefly luciferase is removed and replaced with the fused *X. luminescens luxAB* genes.

Where stable episomal maintenance or integration is desired, a plasmid will be employed which has a replication system that is functional in the host. The replication system may be derived from the chromosome, an episomal element normally present in the host or a different host, or a replication system from a virus that is stable in the host.

5 A large number of plasmids are available, such as pBR322, pACYC184, RSF1010, pR01614, and the like. See for example, Olsen *et al.*, 1982; Bagdasarian *et al.*, 1981, and U. S. Patent 4,356,270, U. S. Patent 4,362,817, U. S. Patent 4,371,625, and U. S. Patent 5,441,884, each of which is incorporated specifically herein by reference.

10 The desired gene can be introduced between the transcriptional and translational initiation region and the transcriptional and translational termination region, so as to be under the regulatory control of the initiation region. This construct will be included in a plasmid, which will include at least one replication system, but may include more than one, where one replication system is employed for cloning during the development of the plasmid and the second replication system is necessary for functioning in the ultimate
15 host. In addition, one or more markers may be present, which have been described previously. Where integration is desired, the plasmid will desirably include a sequence homologous with the host genome.

The transformants can be isolated in accordance with conventional ways, usually employing a selection technique, which allows for selection of the desired organism as
20 against unmodified organisms or transferring organisms, when present. The transformants then can be tested for bioluminescence or chemiluminescence activity. If desired, unwanted or ancillary DNA sequences may be selectively removed from the recombinant bacterium by employing site-specific recombination systems, such as those described in U. S. Patent 5,441,884, specifically incorporated herein by reference in its entirety.

25

4.9 ASSEMBLY AND STORAGE OF THE *IN VIVO* BIOSENSOR

When the biosensor consists of bioengineered cells entrapped in suspension behind a semi-permeable membrane, as opposed to encapsulated in a matrix, the cells may be added to the BBIC any time from immediately to several h before implantation of the
30 biosensor. The biosensor may alternatively consist of cells encapsulated in a polymeric matrix. Matrices will include materials previously shown to be successful in the encapsulation of living cells, including polyvinyl alcohol, sol-gel, and alginate (Cassidy *et*

al., 1996). Prior to encapsulation, prokaryotic cell lines may be lyophilized in a freeze dry system (*e.g.*, Savant) following the manufacturer's protocol. Lyophilization allows cells to undergo periods of long-term storage (several years) with a simple rehydration protocol being required for cell resuscitation prior to BBIC use (Malik *et al.*, 1993). *S. cerevisiae* eukaryotic cells may be similarly lyophilized. Eukaryotic cell lines, preferably consisting of islet β -cells, stem cells, or hepatic cells, may be encapsulated on the IC within polyvinyl alcohol mesh-reinforced or microporous filter supported hydrogels, which have previously been successfully implemented in these types of cell encapsulations (Baker *et al.*, 1997; Burczak *et al.*, 1996; Gu *et al.*, 1994; Inoue *et al.*, 1991).

In the case of the mammalian cell lines, lyophilization, however, is not an alternative. In such cases, mammalian cells may be encapsulated in a sol gel or another immobilization matrix as previously described and attached to the BBIC. The completed BBIC in its enclosure would then be stored in serum or another appropriate maintenance medium and maintained until use. The advantage of using an immortal stem cell line is apparent for both long-term use and storage. Implantation may be performed according to the specific application. In the case of glucose detection, an area where interstitial fluid is accessible would be most appropriate. However an implantable device with the specific application of detecting hormones or other blood borne molecules would have to be accessible to the bloodstream. A synthetic vein or catheter system may need to be employed to allow continuous monitoring of the blood levels of the target molecule. A specific example other than glucose would be the use of the *in vivo* biosensor device to detect molecules associated with colon cancer. In this case the biosensor would be implanted in the colon.

Integrated circuits may be individually packaged in sterile, static-proof bags. Prokaryotic-based and yeast eukaryotic biosensors consisting of lyophilized cells may be individually stored in sterile, static-proof, vacuum sealed bags for time periods approaching several years. Cells typically undergo rehydration in a minimal nutrient medium prior to use. Mammalian cell systems will remain frozen for long-term storage (up to 7 years at -150°C) or refrigerated for short-term storage (several days), either separately or, if entrapped, frozen or refrigerated *in situ* on the BBIC. In all cases, cell viability may be checked by exposing the BBIC to a known concentration of the analyte of interest, thus producing a quantitative bioluminescent signal of known magnitude. One

or more control vials of analyte(s) or reference "standards" may be included as part of a diagnostic kit, or may be supplied for proper calibration of the implantable device.

4.10 IMPLANTATION AND USE OF THE BIOSENSOR DEVICES

5 In a preferred embodiment of the present invention, the BBIC analyte biosensor is implanted such that it is contact with the interstitial fluid of the animal. For example, in the case of glucose biosensors, it has been shown that glucose kinetics in interstitial fluid can be predicted by compartmental modeling (Gastaldelli *et al.*, 1997). In particular the subcutaneous placement of glucose sensors has been demonstrated (Schmidt *et al.*, 1993; 10 Poitout *et al.*, 1993; Ward *et al.*, 1994; Stenberg *et al.*, 1995; Bantle and Thomas, 1997). Other potential analyte biosensor tissue implant sites include the peritoneum, pleura and pericardium (Wolfson *et al.*, 1982). In fact, the inventors contemplate that depending upon the particular analyte or metabolite that is being detected, the implantable biosensor may be placed in any convenient location throughout the body using conventional surgical and implant methodologies. For example, the device may be implanted in such as way as 15 to be in contact with interstitial fluid, lymph fluid, blood, serum, synovial or cerebrospinal fluid depending upon the particular analyte to be detected.

In certain embodiments the implantable device may be placed in contact with particular tissues, organs, or particular organ systems. Likewise, it may be desirable to 20 implant the biosensor such that it contacts particular intracellular fluids, intercellular fluids, or any other body fluid in which the target substance can be monitored.

The present invention also contemplates the use of multiple biosensors for the detection of a plurality of different analytes. For example, in the case of glucose monitoring, one or more devices may be used to monitor various glucose or glucose 25 metabolites, glucagons, insulin, and the like. Likewise, one or more biosensor devices may be employed in controlled drug delivery systems. As such, the device may be operably connected to a drug delivery pump or device that is capable of being controlled by the biosensor and that is able to introduce into the body of the animal an amount of a particular drug, hormone, protein, peptide, or other pharmaceutical composition 30 determined by the concentration of one or more analytes detected by the BBIC device. Thus, controlled drug delivery systems are contemplated by the inventors to be particularly desirable in providing long-term administration of drugs to an animal such as

in the case of chronic or life-long medical conditions or where symptoms persist for a long period of time. The long term controlled delivery of drugs such as pain medications, heart or other cardiac regulators, diuretics, or hormones or peptides such as insulin, or metabolites such as glucagon or glucose can be facilitated by such biosensor/pump systems. In cases where it is necessary to deliver more than one drug or metabolite to the animal, multiple drug delivery systems or a single switchable drug delivery system is contemplated to be particularly useful.

Host-rejection effects can be minimized through immunoisolation techniques. Previous studies have shown that living non-host cells enclosed in hydrogel membranes are protected from immune rejection after transplantation (Baker *et al.*, 1997; Burczak *et al.*, 1996; Inoue *et al.*, 1991). The hydrogels block access by the humoral and cellular components of the host's immune system but will remain permeable to the target substance glucose. A mesh-reinforced polyvinyl alcohol hydrogel bag developed by Gu *et al.* (1994) may be used to fully encapsulate the BBIC, allowing for transplantation void of immunosuppressive responses.

Host rejection of the implanted biosensor is not an issue if cells from the host are used for the biosensor construction. However if other cell lines are used it may be necessary to provide a barrier between the cells and the appropriate body fluid that permits passage of the signature molecules or analytes but not bioreporter cells or body cells (white blood cells, *etc.*). Immunosuppressed patients are not affected, as the implant does not contain any kind of pathogenic agent that would affect the patient. In all cases, the surgical methods involved in implantation of the disclosed BBIC devices are well known to one of skill in the surgical arts.

In an illustrative embodiment, the BBIC glucose sensor may be used for monitoring glucose in diabetic patients. However, such a sensor can also be used in other conditions where glucose concentrations are of concern, such as in endurance athletes or other condition involving either hypo- or hyperglycemia. Such measurements may be the end point for investigative or diagnostic purposes or the sensors may be linked *via* telemetry or directly to a drug delivery system.

The use of implantable BBICs for substances other than glucose can be used in a range of therapeutic situations. With the incorporation of an appropriate *cis*-activating response element, BBICs could monitor a number of substances and could find use in

chronic pain treatment, cancer therapy, chronic immunosuppression, hormonal therapy, cholesterol management, and lactate thresholds in heart attack patients. For example, Section 5.7 describes the use of the BBICs in the detection and diagnosis of cancer.

Individual biosensors can be calibrated to check for viability of the cells as well as performance. The calibration is performed by exposing the sensor to solutions containing varying concentrations of the analyte(s) of interest. The bioreporter may be calibrated by a series of standard analyte concentrations for the specific application after its initial construction. The overall on-line performance can be monitored using microfluidics with a reservoir of the analyte, which would systematically provide a known concentration to the cells this would allow both calibration and test for viability.

The luminescence response is then correlated to concentration and the parameters set. Viability can also be continuously monitored by bioengineered cells in which the reporter exhibits continuous luminescence. Loss of viability results in decreased luminescence. This technique has been used to detect the viability of prokaryotic cells. Thus the BBIC would contain two bioreporters, the bioreporter detecting the selected substance and the second bioreporter exhibiting a luminescence proportional to cell viability. Measurement of the ratio of the signals from the two bioreporters would give a detection method that would automatically correct for any loss in viability.

Once prepared the bioreporters can be stored in the appropriate maintenance medium (*e.g.*, standard tissue culture media, sera, or other suitable growth or nutrient formulations), and then calibrated prior to implantation. The viability of the devices may be checked by bioluminescence using microfluidics, or by the quantiation of known standards or other reference solutions to ensure viability and integrity of the system prior to, or after implantation..

In certain embodiments of the invention, the monolithic biosensor devices may be used external to the body of the monitored individual. In some clinical settings the monitor may be used to monitor glucose in body fluids in an extracorporeal fashion. The device may even be used in the pathological or forensic arts to detect the quantity of particular analytes in body tissues or fluids and the like. Likewise, the present invention also contemplates use of the biosensor devices in the veterinary arts. Implantation of such devices in animals for the monitoring of hormone levels in the blood (*i.e.* for optimizing milk production), monitoring the onset of estrous (heat) in numerous animals to maximize

artificial insemination efficiency, and monitoring hormone levels in the milk produced on-line (in the udder) *etc.* is contemplated to provide particular benefits to commercial farming operations, livestock industries and for use by artisans skilled in veterinary medicine.

5

4.11 DIAGNOSTICS KITS COMPRISING *IN VIVO* BIOSENSORS

While the individual components of the invention described herein may be obtained and assembled individually, the inventors contemplate that, for convenience, the components of the biosensor may be packaged in kit form. Kits may comprise, in suitable container means, one or more bioreporters and an integrated circuit including a phototransducer. The kit will also preferably contain instructions for the use of the biosensor apparatus, and may further, optionally comprise a drug delivery device or a second biosensor apparatus. The kit may comprise a single container means that contains one or more bioreporters and the integrated circuit including a phototransducer and drug delivery device. Alternatively, the kits of the invention may comprise distinct container means for each component. In such cases, one container would contain one or more bioreporters, either in an appropriate medium or pre-encapsulated in a polymer matrix, another container would include the integrated circuit, and another container would include the drug delivery device. When the bioreporter is pre-encapsulated, the kit may contain one or more encapsulation media. The use of distinct container means for each component would allow for the modulation of various components of the kits. For example, several bioreporters may be available to choose from, depending on the substance one wishes to detect. By replacing the bioreporter, one may be able to utilize the remaining components of the kit for an entirely different purpose, thus allowing reuse of components.

The container means may be a container such as a vial, test tube, packet, sleeve, shrink-wrap, or other container means, into which the components of the kit may be placed. The bioreporter or any reagents may also be partitioned into smaller containers or delivery vehicles, should this be desired.

The kits of the present invention also may include a means for containing the individual containers in close confinement for commercial sale, such as, *e.g.*, injection or blow-molded plastic containers into which the desired components of the kit are retained.

Irrespective of the number of containers, the kits of the invention also may comprise, or be packaged with, an instrument for assisting with the placement of the bioreporter upon the integrated circuit. Such an instrument may be a syringe, pipette, forceps, or any other similar surgical or implantation device. The kit may also comprise
5 one or more stents, catheters, or other surgical instrument to facilitate implantation within the body of the target animal. Such kits may also comprise devices for remote telemetry or devices for data storage or long term recordation of the data obtained from the monitoring device. Likewise, in the case of controlled drug delivery systems, the kits may comprise one or more drug delivery pumps as described above, and may also comprise
10 one or more pharmaceutical agents themselves for administration. As an example, in the case of a glucose monitoring system, the system would typically comprise a glucose-sensitive BBIC device, a drug delivery pump, instructions for the implantation and/or use of the system, and optionally, reference standards or pharmaceutical formulations of insulin, glucagon or other pharmaceutical composition. The system may also optionally
15 comprise growth and/or storage medium to support the nutritive needs of the bioreporter cells comprised within the BBIC device.

5.0 EXAMPLES

The following examples are included to demonstrate preferred embodiments of the
20 invention. It should be appreciated by those of skill in the art that the techniques disclosed in the examples which follow represent techniques discovered by the inventor to function well in the practice of the invention, and thus can be considered to constitute preferred modes for its practice. However, those of skill in the art should, in light of the present disclosure, appreciate that many changes can be made in the specific embodiments
25 which are disclosed and still obtain a like or similar result without departing from the spirit and scope of the invention.

5.1 EXAMPLE 1 -- CONSTRUCTION OF A BIOLUMINESCENCE REPORTER FOR MAMMALIAN CELL LINES

30 To facilitate the construction of an implantable bioluminescent glucose sensor it will be necessary to create a bioluminescent reporter system that can function without the exogenous addition of substrate for the luciferase reaction. This exogenous addition is

due to the complex nature of the production of luciferins for the various eukaryotic luciferases. Cells must be either permeabilized or lysed and then treated with an assay solution containing luciferin. Therefore, the present state of bioluminescence reporters used in eukaryotic molecular biology makes them unsuitable for "on-line" monitoring.

5 The firefly luciferase has been used in examining the regulation of L-pyruvate kinase promoter activity in single living rat islet β -cells (Kennedy *et al.*, 1997). However, these cells had to be perfused with Beetle luciferin in order to generate a luminescence response.

To alleviate this limitation, a preferred bioluminescent reporter system for the present invention is one that does not require the addition of exogenous substrate. In the case of bacterial luciferase-based detection systems, this may be accomplished using the bioluminescent genes from *X. luminescens*. In this organism, *luxA* and *luxB* genes (or a single fused *luxAluxB* gene encode the α - and β -subunits, respectively, of the luciferase enzyme (Meighen *et al.*, 1991). This luciferase exhibits greatest thermostability at 37°C

10 while other bacterial luciferases lose significant activity above 30°C. Therefore, these bacterial luciferases can be expressed in eukaryotic cells with slight modification. Almashanu *et al.* (1990) fused the *luxAB* genes from *V. harveyi* by removal of the TAA stop codon from *luxA*, the intervening region between the two genes, and the initial methionine from *luxB* without disrupting the reading frame. The fusion was successfully

15 expressed in *S. cerevisiae* and *D. melanogaster*. Using the same strategy a fused *luxAB* gene sequence was developed using the genes from *X. luminescens*.

To eliminate the need for the addition of exogenous substrate, cells must themselves supply the appropriate substrate for the luciferase. In the bacterial system the substrate is generated by a fatty acid reductase complex encoded by the *luxCDE* genes.

20 This enzyme complex reduces short chain fatty acids to the corresponding aldehyde. The luciferase then oxidizes the aldehyde to the corresponding fatty acid. The preferred fatty acid for this reaction is myristic acid, which is present in eukaryotic organisms (Rudnick *et al.*, 1993). Myristic acid is usually involved in the myristoylation of the amino terminus that is associated with membrane attachment (Borgese *et al.*, 1996, Brand *et al.*,

25 1996). Thus, to obviate the need for an exogenous supply of the luciferase substrate, the biosensor also preferably comprises a nucleic acid sequence that encodes the three *luxC*, *luxD*, and *luxE*-encoded subunits. As in the case of the *luxAluxB* gene fusion, the *luxC*,

30

luxD, and *luxE* genes have been fused to produce a single *luxCDE* gene fusion that encodes the three subunits of the enzyme complex. The methods of preparing such gene fusions are described below:

5 5.1.1 FUSION OF THE *LUXAB* AND *LUXCDE* GENES

The *luxAB* genes may be fused using conventional molecular biology techniques. For example, the polymerase chain reaction may be routinely employed for this purpose. By synthesizing a 5'-primer whose sequence begins with ATG for the start codon for the *luxA* gene juxtaposed by a 3'-primer ending with the codon immediately preceding the
10 ATT stop codon. These primers may then be used in amplification reactions and the product gel purified. The *luxB* gene may also be amplified as above using primers that eliminate the ATG initial methionine codon but preserve the reading frame. The PCR™ reactions employ a thermostable polymerase such as the Pfu™ polymerase of Stratagene (La Jolla, CA), which does not have terminal deoxytransferase activity and therefore
15 generates a blunt end. The resultant PCR™ products are blunt-end ligated, and the ligation is then subjected to PCR™ using the 5'-primer from *luxA* and the 3'-primer from *luxB* using Taq polymerase to facilitate TA cloning (Invitrogen, San Diego, CA). Only ligations with the correct orientation of fragments are amplified. The *luxAB* amplicon is then gel purified and TA cloned into a suitable vector (such as the PCRII™ vector) and
20 transformed into *E. coli* using standard manufacturer's protocols.

Transformants are screened for light production by the addition of *n*-decanal which, when oxidized by the luciferase, generates bioluminescence. Only colonies emitting light are selected since they are in the proper orientation for further genetic manipulation. The *luxCDE* fusion is generated using the same strategy as above except
25 transformants are screened by minipreps followed by restriction digestion analysis to determine orientation. Plasmids are amplified in *E. coli*, recovered and purified twice on CsCl gradients.

5.1.2 EXPRESSION OF *LUXAB* AND *LUXCDE* IN HELA CELLS

30 To determine the relative activity of the fused bacterial luciferase components, cloned fragments containing *luxAB* are cloned into a suitable mammalian expression vector (such as pcDNA 3.1 and *luxCDE*-containing fragments are cloned into a suitable

mammalian expression vector (such as pcDNA/Zeo 3.1) (Invitrogen, Faraday, CA). Both vectors constitutively express inserted genes. HeLa cells are then transfected with *luxAB* or both *luxAB* and *luxCDE* and selected using appropriate antibiotics following the manufacturer's protocol (Promega, Madison, WI). Cells receiving the *luxAB* fusion are exposed to *n*-decanal and checked for bioluminescence. These cells cotransfected with *luxCDE* are then examined for bioluminescence to ascertain the relative expression of the *luxCDE* fusion. This permits the comparison of bioluminescence *via* the addition of exogenous aldehyde versus aldehyde that is produced endogenously.

An alternate strategy to enhance bioluminescent expression involves engineering a vector that would contain three copies of the eukaryotic expression machinery contained in pcDNA3.1 (Stratagene, La Jolla, CA). This allows for the expression of the individual components of *luxCDE* since it has already been shown that the fused luciferase is expressed in eukaryotic cell lines (Almashanu *et al.*, 1990).

5.2 EXAMPLE 2 -- CONSTRUCTION OF A GLUCOSE BIOLUMINESCENT BIOSENSOR

The firefly luciferase has been used in examining the regulation of L-pyruvate kinase promoter activity in single living islet β -cells (Kennedy *et al.*, 1997). A glucose response element designated the L4 box has been determined to be in the proximal promoter. A 200-bp fragment containing this region was cloned in front of the firefly luciferase (*luc*) in plasmid pGL3Basic resulting in a glucose reporter plasmid designated p.LPK.Luc_{FF}. Results resulted in the detection of single cells that were exposed to 16 mM glucose but not 3 mM glucose. However, these cells had to be perfused with Beetle luciferin making it unacceptable for an on-line biosensor. Therefore, a bioluminescent sensor for glucose was constructed by replacing the firefly luciferase in p.LPK.Luc_{FF} with the fused *luxAB* gene as described below.

5.3 EXAMPLE 3 -- BIOLUMINESCENT REPORTER CONSTRUCTION AND TRANSFECTION OF RAT ISLET β -CELLS

The bioluminescent reporter plasmid was constructed by removing the *luc* gene coding for the firefly luciferase from p.LPK.Luc_{FF} and replacing it with the fused *luxAB* gene. This was accomplished by cleaving the *luc* gene from p.LPK.Luc_{FF} and cloning in

the *luxAB* gene. The resultant plasmid was amplified in *E. coli* and the plasmid DNA extracted and double purified on CsCl gradients.

Islet cells were prepared as previously described (German *et al.*, 1990) and transfected by electroporation with the bioluminescent reporter construct and the plasmid containing the constitutively expressed *luxCDE* construct. This configuration causes the cells to maintain a pool of the aldehyde substrate that is available to the reporter genes (*luxAB*). Cells were screened for light production in a range of glucose concentrations from 3 mM to 30 mM. Transfected cells were washed, concentrated, and placed in a microwell in a light-tight cell that is then affixed to the integrated circuit. Different concentrations of glucose and assay media (Kennedy *et al.*, 1997) were added to the cells to examine sensitivity and response time of the glucose BBIC.

5.4 EXAMPLE 4 – PREPARATION OF BIOLUMINESCENT REPORTER CONSTRUCTS

The use of reporter gene technology is widespread in studying gene regulation in both eukaryotic and prokaryotic systems. Various genes are used depending on the cell lines being investigated. However with the BBIC technology the use of reporter genes that result in the emission of light is required. Therefore, reporter genes coding for bioluminescence are utilized. All previously developed reporters utilizing other reporter genes for example the gene coding for β -galactosidase (*lacZ*) may be converted to the bioluminescent version using standard molecular techniques and the reporter genes utilized in this specific application (modified *lux* system). Therefore, any currently existing reporter cell line for testing gene expression in mammalian cell lines may be adapted for use as a bioreporter when converted to the *lux* reporter. The implantable system simply contains the appropriate reporter cell line. Table 1 shows a list of examples of eukaryotic reporter cell lines that may be exploited in an implantable biosensor.

TABLE 1

Reporter Gene Fusion	Application	Reference
ADH4-LUC	Monitors expression of alcohol dehydrogenase to increasing concentrations of alcohol	Edenberg <i>et al.</i> , 1999
TH-lacZ	Shows increased gene expression in mice subjected to chronic cocaine or morphine exposure	Boundy <i>et al.</i> , 1998
Estrogen regulated-LUC	Detects estrogens and xenoestrogens by their effect on the estrogen response element	Balaguer <i>et al.</i> , 1999
IGFBP-5-LUC	Detects the presence of progesterone by the upregulation of the reporter construct	Boonyaratanakornkit <i>et al.</i> , 1999
CYP1A-lacZ	Detects compounds that cause an upregulation of cytochrome P450 (potential carcinogens)	Campbell <i>et al.</i> , 1996

5.5 EXAMPLE 5 -- CONSTRUCTION AND IMPLANTATION OF A

GLUCOSE BIOSENSOR AND INSULIN DELIVERY PUMP

5 In one embodiment, a pair of bioluminescent reporters may be utilized that are in tandem and that specifically respond to deviations in glucose concentrations. One bioreporter utilizes the *luxAB* and *luxCDE* genes from *X. luminescens* incorporated into a plasmid-based system designated p.LPK.Luc_{FF}, which contains a eukaryotic *luc* gene able to respond to glucose concentrations (increasing bioluminescence corresponds to increasing glucose concentrations). The second bioreporter utilizes a plasmid construct containing the promoter for the phosphoenolpyruvate carboxylase gene (PEPCK) that also responds to glucose concentrations, except increased bioluminescence corresponds to decreased levels of glucose. The incorporation of the *luxAB* and *luxCDE* genes into each construct allow for bioluminescence measurements to occur in real-time with deviations in glucose concentrations, negating the requirement for cell destruction and substrate addition.

15 In this embodiment, the integrated circuit comprises separate photodetector units for each bioreporter (FIG. 9A, FIG. 9B, and FIG. 9C). Bioluminescent responses from each construct can be independently monitored, allowing for the signal processing circuitry to differentiate between one bioreporter's response to increased glucose concentrations and the second bioreporter's response to decreased glucose concentrations.

The signal processing circuitry processes the signals from the photodetectors, converts it to a digital format and relays the information to the implanted insulin pump (FIG. 10). The tandem set of bioreporters allows a more accurate signal as well as redundancy in the detector. Due to the often-fatal outcome of hypoglycemia, this tandem system also allows
5 for more careful monitoring and warning of the onset of hypoglycemia.

The cells used in the tandem bioreporter system may be affixed to each of the photodetectors either directly by attachment or encapsulated in hydrogel (Prevost *et al.*, 1997). It may be necessary to isolate the bioreporters using a semi-permeable membrane to allow the transport of small molecules such as glucose and insulin across the membrane
10 and prohibit the influx of immune effector cells and antibodies (Monaco *et al.*, 1993, Suzuki *et al.*, 1998). However small molecules such as cytokines can still enter the selective membranes and interfere with the bioluminescent reporter cell lines. This approach has been used extensively by those of skill in the art.

When applicable, bioluminescent reporter cell lines may be constructed from cells
15 taken directly from the patient to receive the implant. This approach is particularly desirable in cases of long-term implants such as implantable insulin delivery. Cells may be obtained from the patient, genetically engineered for the appropriate monitoring function, grown in cell culture, evaluated and then preserved for long-term storage. The use of cell lines developed from the patient's own cells, is particularly desirable as it
20 reduces the chance of host rejection and creation of an immune response to the implanted device. Preferably, stem cells (immortal stem cells, if attainable) are used when appropriate, and may be maintained and nourished in suitable culture medium. Such pluripotent, totipotent, or otherwise immortal cell lines provide particular advantage in the creation of suitable long-term implantable devices.

Before implantation the biosensor may be calibrated injecting the chamber
25 containing the cells with various concentrations of glucose delivered from an auxiliary pump and reservoir on the insulin delivery pump (FIG. 10). This permits determination of the appropriate parameters to allow the proper dosage of insulin to be delivered. Once the parameters are set, the pump may be evaluated for insulin delivery. Systematically the
30 glucose biosensor is recalibrated in the patient utilizing the glucose standard contained in the delivery pump.

In the case of drug delivery systems, the glucose biosensor may be operably connected to the delivery pump *via* a hardwire or wireless connection. The biochip provides digital data that may be input directly to the signal processing circuitry of the pump to proportionally dispense the insulin. Alternatively, the digital data may be converted into analog data and used to control the pump. When a wireless capability is added to the bioreporter device, remote monitoring of the sensor is possible. For example, in this configuration, the patient may place a radio transmitter/receiver outside the body near the implanted device to communicate the data from the implanted device to a remote station. In some applications, the radio transmitter/receiver may be linked to a computer programmed to forward the data to a remote station over a network such as a local area network, a wide area network, or even the Internet. Such wireless applications allow remote monitoring and maintenance of the patients. There are several pumps currently on the market, which are candidates for interfacing with the biosensor. In one embodiment, the Medtronic Synchronized infusion system may be used as it has extensively used in drug delivery and utilizes a portable computer to allow programming of the pump from outside the body (www.asri.edu/neuro/brochure/pain6.htm). The pump can also be refilled through the skin *via* a self-sealing septum. The pump is one inch thick and three inches in diameter and weighs approximately six ounces. The biosensor can be integrated into the preexisting electronic circuitry to take advantage of the out-of-body programming by a portable computer. The chip can be powered utilizing the battery that powers the delivery pump.

The biosensor/insulin pump apparatus may be surgically implanted using local anesthesia in the abdominal cavity. Both the sensor and the pump may be implanted in the peritoneal space of the abdomen both for simplicity and to avoid the complications of direct catheter placement in the blood stream. Glucose concentrations are monitored and the insulin delivered peritoneally as required by the patient (FIG. 10).

5.6 EXAMPLE 6 -- BIOLUMINESCENT REPORTER CONSTRUCTION AND

TRANSFECTION OF RAT ISLET β -CELLS AND H4IIE HEPATOMA CELLS

The regulation of the PEPCK gene will be exploited in the construction of the bioluminescent reporter for detecting decreased glucose concentrations. This system is highly regulated as the phosphoenolpyruvate carboxylase is the rate-limiting enzyme in

gluconeogenesis. PEPCK gene expression is increased in the presence of glucocorticoids and cAMP and decreased in the presence of insulin (Sasaki *et al.*, 1984; Short *et al.*, 1986). In both rat liver and H4IIE hepatoma cells the insulin effect is dominant and the glucocorticoids and cAMP is additive. The promoter region of the PEPCK will be cloned
5 in front of the fused *luxAB*. The resultant construct will then produce increased bioluminescence in the presence of low glucose concentrations.

The bioluminescent reporter plasmid for detecting increased glucose concentration may be constructed by removing the *luc* gene coding for the firefly luciferase from p.LPK.Luc_{FF} and replacing it with the fused *luxAB*. This is accomplished by cleaving the
10 *luc* gene from p.LPK.Luc_{FF} and cloning in the *luxAB* gene. The bioluminescent reporter plasmid for the detection of low glucose concentrations is constructed by replacing the chloramphenicol transferase (CAT) gene in the previously constructed PEPCK promoter CAT fusion (Petersen *et al.*, 1988; Quinn *et al.*, 1988) with the *luxAB* gene. The resultant plasmid is amplified in *E. coli* and the plasmid DNA extracted and double purified on
15 CsCl gradients.

Islet and hepatoma cells may be prepared as previously described (German *et al.*, 1990; Petersen *et al.*, 1988) and co-transfected with the bioluminescent reporter construct and the plasmid containing the constitutively expressed *luxCDE* gene constructed in
20 objective one. This configuration causes the cells to maintain a pool of aldehyde substrate that will be available to the reporter genes (*luxAB*). Cells are screened for light production in a range of glucose concentrations from 3 mM to 30 mM. Transfected cells are washed, concentrated, and placed in a microwell in a light-tight chamber that is then affixed to the integrated circuit. Different concentrations of glucose and assay media (Kennedy *et al.*,
25 1997) are added to the cells to examine sensitivity and response time of the glucose BBIC. After initial characterization, the bioluminescent glucose reporters may also be tested in a flow cell. Cells are placed in an encapsulation medium on the integrated circuit and media containing different concentrations of glucose (3-to-30 mM) is then perfused across the cells to examine dynamic responses.

30 5.7 EXAMPLE 7 – BBICs IN THE DIAGNOSIS AND DETECTION OF CANCER

Colon cancer is the second leading cause of cancer death after lung cancer in the United States, and the incidence increases with age in that 97% of colon cancer occurs in

persons greater than 40 (Coppola and Karl, 1998). Although most cases of colon cancer are sporadic, in 15% of the patients there is a strong familial history of similar tumors in first-degree relative relatives (Coppola and Karl, 1998). These familial cancers such as hereditary nonpolyposis colon cancer (HNPCC) and familial adenomatous polyposis (FAP) result from autosomal dominant inheritable genetic mutations in putative tumor suppressor genes, and a spectrum of lesions occurs from hyperplasia-dysplasia-adenoma-carcinoma (Coppola and Karl, 1998). Because much of the early molecular lesions are known about inherited colonic cancer, they represent a useful model for development of a novel biosensor strategy for early clinical detection. Biosensors are hybrid devices combining a biological component with a computerized measuring transducer.

This example describes the adaptation of the implantable biosensor device to permit early detection of cancers, and to permit means for monitoring remission and recurrence of cancer. Because the miniaturized biosensors of the present invention are small enough to be implantable, and can be combined with a reporter system engineered to produce light without the need for cellular lysis or additional substrate, a powerful tool for early diagnosis of colon cancer in the form of an implantable device is now possible for the first time.

As described above for glucose and other metabolite biosensors, the inducible reporter system utilized is based on the *luxAB* and *luxCDE* genes from *X. luminescens* placed in a eukaryotic reporter cell so that expression of certain genes or their products can be detected by expression of bioluminescence by the BBICdevice. The eukaryotic reporter cell is treated with mitomycin C so it is unable to divide, but is still able to respond metabolically and produce a quantitative bioluminescent signal.

Colon cancer is the second leading cause of cancer death in the United States, with at least 50% of the population developing a colorectal tumor by the age of 70 (Kinzler and Vogelstein, 1996). Although most cases of colorectal cancer are sporadic, 15% are the result of heritable cancer syndromes, familial adenomatous polyposis (FAP) and hereditary nonpolyposis colorectal cancer (HNPCC) (Kinzler and Vogelstein, 1996). Familial adenomatous polyposis is a syndrome characterized by the development of hundreds to thousands of adenomas or polyps in the colon and rectum, only a small number of which develop into invasive cancer (Kinzler and Vogelstein, 1996). Loss of function of both alleles of the *adenomatous polyposis coli* (*APC*) tumor suppressor gene

predisposes persons to develop malignant cancer (Coppola and Marks, 1998). In addition, most sporadic colon cancers are also found to contain mutations in the *APC* gene (Kinzler and Vogelstein, 1996). In hereditary nonpolyposis colorectal cancer, there is marked microsatellite instability secondary to mutations in DNA mismatch repair genes such as *hMSH2* and *hMSH1*; single, high grade tumors develop at a young age and are usually confined to the right colon (Coppola and Karl, 1996; Smyrk, 1994). Whereas cells with mutations in *APC* are generally aneuploid from loss of whole sections of chromosomes, cells with mutations in *hMSH2* or *hMSH1* are euploid (Lengauer *et al.*, 1998).

The molecular events leading to the development of colonic neoplasia are fairly well understood (Kinzler and Vogelstein, 1996). Persons with complete loss of APC develop lesions in the colon called dysplastic aberrant crypt foci that progress to early adenomas (Kinzler and Vogelstein, 1996). Other mutations begin to accumulate, such as those in K-Ras or p53, and the tumors progress to late adenomas, carcinomas, and metastatic carcinomas (Kinzler and Vogelstein, 1996). A similar progression is seen in HNPCC as well. Because the sequence of genetic events is fairly well understood for both these types of cancer, they represent excellent models for development of sensitive and specific diagnostic tests that can be used to detect one or more altered cells *in vitro*.

The *APC* gene encodes a cytoplasmic protein that localizes to the ends of microtubules at focal adhesion complexes (Kinzler and Vogelstein, 1996). As cells migrate up through the crypts, expression of APC increases until the terminally differentiated and located colonic epithelial cells undergo apoptosis (Kinzler and Vogelstein, 1996). Cadherins are transmembrane proteins that are localized to focal adhesion plaques in most epithelial cells (Aplin *et al.*, 1998). The carboxy terminus of each cadherin interacts with cytoplasmic structural proteins known as catenins (Aplin *et al.*, 1998). There are three types of catenins: β -catenin binds to the cytoplasmic domain of cadherin; γ -catenin binds to β -catenin and the actin cytoskeleton via α -actinin; δ -catenin functions in place of β -catenin in some cell types (Aplin *et al.*, 1998). β -Catenin also is part of a signal transduction pathway involving the secreted glycoprotein Wnt and glycogen synthase kinase 3 (GSK3) (Aplin *et al.*, 1998). APC interacts with several components of the Wnt- β -catenin-GSK3 pathway, including β - and γ -catenins, GSK3, and tubulin (Aplin *et al.*, 1998). Most of the mutations in colorectal cancer are in the carboxy terminal region of APC so that it can no longer bind β -catenin (Aplin *et al.*, 1998). In

fact, β -catenin lies downstream of APC and is critical for its function as a tumor suppressor gene (Aplin *et al.*, 1998). When the Wnt pathway is inactivated, GSK3 phosphorylates the N-terminus of β -catenin, targeting it for degradation by the ubiquitin pathway (Munemitsu *et al.*, 1996). When β -catenin accumulates, it activates gene transcription via the transcription factor Lef-1/TCF (Morin *et al.*, 1997). APC works in concert with GSK3 to inhibit β -catenin-mediated transcriptional activity (Kinzler and Vogelstein, 1996).

In hereditary nonpolyposis colon cancer, microsatellite instability is the result of mutations in one or more DNA-mismatch repair genes (Jiricny 1998; Nicholaides *et al.*, 1994). At least 90% of HNPCC tumors have microsatellite instability (Karran 1996; Smyrk 1994). One potential marker for microsatellite instability in colorectal tumors is inactivation of the type II receptor for TGF- β (Markowitz *et al.*, 1995). Loss of function of β RII is associated with loss of growth regulation and tumor progression in colorectal adenomas in HNPCC (Wang *et al.*, 1995). Other signaling components of the TGF- β pathway that are involved in colorectal tumorigenesis include mutations in Smad 3 and Smad 4, both of which result in the development of colorectal adenocarcinomas in mice (Zhu *et al.*, 1998; Takaku *et al.*, 1998). Loss of function of β RII is a useful marker for early lesions in HNPCC (Markowitz *et al.*, 1995).

Because mutations in *APC* are the most common mutations in colorectal cancer, a reporter construct for T cell transcription factor (Tcf) was devised to screen multiple colon cancer cell lines for activation of transcriptional activity. Mutations in either *APC* or β -catenin result in activation of Tcf-responsive transcription through the accumulation of unphosphorylated cytoplasmic β -catenin (Morin *et al.*, 1997) and detecting activation of a reporter construct is useful as a marker for mutations in either of these genes. The vector pDISPLAY (Invitrogen) permits expression of the promoter for Tcf on the surface of the bioreporter cell; this construct consists of a tandem set of Tcf promoters: one upstream of the genes for *luxAB*, the other upstream of the *luxCDE*. In the presence of excess β -catenin the promoter constructs will stimulate activity of the reporter and bioluminescence will result.

Once the HepG2 and HeLa cells have been transfected with pcDNA3 encoding the *luxAB* genes, the cells are attached to the biosensor chip. It is necessary to insure that these cells are incapable of dividing, so after transfection and selection, the cells are irradiated with 6,000 rads γ -radiation from a ^{60}Co source (UT College of Veterinary

Medicine). In some embodiment it may be necessary to attach the cells to the biochip prior to irradiation so that efficient attachment can occur. An alternative is to treat the cells with mitomycin C to prevent further mitosis. Biochips may be coated with Matrigel, a basement membrane material that promotes attachment of epithelial cells. An alternative approach suspends the cells in Matrigel and allows it to form a gel on the surface of the biochip. The cells are then immobilized in the basement membrane material and are not subject to dislodgement by friction. Optionally, the surface of the chip may be altered by adding a net charge (*e.g.*, poly-L-lysine), coating the surface with surgical tissue glue, or by adding some other surface modification that allows the biopolymers to adhere tightly to the surface. Because mutations in *APC* are the most common mutations in colorectal cancer, a reporter construct for T cell transcription factor (Tcf) may be devised to screen multiple colon cancer cell lines for activation of transcriptional activity.

The present invention also provides a biosensor that may be used for endoscopic screening of the colonic mucosa to detect the presence of mutated cells prior to the onset of gross morphological alterations. It may be necessary to attempt detection of more than one abnormality at a time for the degree of sensitivity needed to detect small foci of malignant transformation. For example, many colonic tumors, especially those with mutations in *APC*, overexpress cyclooxygenase-2 (COX-2) and secrete large amounts of prostaglandins (Kutchera *et al.*, 1996; Sheng *et al.*, 1997; Coffey *et al.*, 1997; Kinzler and Vogelstein, 1996). Cyclooxygenase-2 is an early response gene that not constitutively expressed, but is turned on in colonic epithelial cells by growth factors and tumor promoters (Kutchera *et al.*, 1996; Sheng *et al.*, 1997; Coffey *et al.*, 1997). It may be possible to bioengineer reporter cells to bioluminesce in the presence of increased levels of prostaglandins in the intestinal lumen. Prostaglandins freely pass the cell membrane and would be able to enter the cytoplasm of the reporter cell to activate a reporter construct. Engineering a reporter cell to detect increased levels of prostaglandins through the use of the cyclooxygenase-2 promoter fused to the *luxAB* genes could also be of benefit in early detection of colon cancer. Because the levels of prostaglandins may be elevated in inflammation as well as neoplasia, this approach lacks appropriate specificity for diagnosing cancer. It would, however, be useful in determining which patients would benefit from treatment with specific cyclooxygenase inhibitors.

6.0 REFERENCES

The following references, to the extent that they provide exemplary procedural or other details supplementary to those set forth herein, are specifically incorporated herein,
5 by reference.

U. S. Patent 4,332,898, issued Jun 1, 1982.

U. S. Patent 4,342,832, issued Aug 3, 1982.

U. S. Patent 4,356,270, issued Oct 26, 1982.

10 U. S. Patent 4,362,817, issued Dec 7, 1982.

U. S. Patent 4,371,625, issued Feb 1, 1983.

U. S. Patent 5,441,884, issued Aug 15, 1995.

U. S. Patent 4,637,391, issued Jun 16, 1987.

U. S. Patent 4,944,659, issued Jul 31, 1990.

15 U. S. Patent 5,370,684, issued Dec 6, 1994.

U. S. Patent 5,387,247, issued Feb 7, 1995.

U. S. Patent 5,421,816, issued Jul 6, 1995.

U. S. Patent 5,428,123, issued Jun 27, 1995.

U. S. Patent 5,474,552, issued Dec 12, 1995.

20 U. S. Patent 5,569,186, issued Oct 29, 1996.

U. S. Patent 5,620,883, issued Apr 15, 1997.

U. S. Patent 5,653,755, issued Aug 5, 1997.

U. S. Patent 5,711,960, issued Jun 27, 1998.

U. S. Patent 5,779,734, issued Jul 14, 1998.

25 U. S. Patent 5,795,790, issued Aug 18, 1998.

U. S. Patent 5,800,420, issued Sep 1, 1998.

U. S. Patent 5,814,091, issued Sep 29, 1998.

Almashanu, Musafia, Hader. Suissa, Kuhn, "Fusion of *luxA* and *luxB* and its expression in
Escherichia coli, *Saccharomyces cerevisiae* and *Drosophila melanogaster*," *J.*
30 *Biolum. Chemilum.* 5(2):89-98, 1990.

- Anderson, Rossi, Tukey, Vu, Quattrochi, "A biomarker, P450 RGS. for assessing the induction potential of environmental samples," *Environ. Toxicol. Chem.*, 14:1159-1169, 1995.
- Andrew and Roberts, "Construction of a bioluminescent Mycobacterium and its use for assay of antimycobacterial agents," *J. Clin. Microbiol.*, 31:2251-2254, 1993.
- Aplin, Howe, Alahari and Juliano, "Signal transduction and signal modulation by cell adhesion receptors: the role of integrins, cadherins, immunoglobulin-cell adhesion molecules, and selectins," *Pharmacol. Rev.*, 50:197-263, 1998.
- Applegate, Kehrmeyer and Saylor, "A modified mini-Tn5 system for chromosomally-introduced *lux* reporters for chemical sensing," *Appl. Environ. Microbiol.*, 64:XXX-XXX, 1998.
- Atanasov, Yang, Salehi, Ghindilis, Wilkins, Schade, "Implantation of a refillable glucose monitoring-telemetry device," *Biosensors and Bioelectron.*, 12:669-80, '997.
- Bagdasarian, Lurz, Ruckert, Franklin, Bagdasarian, Frey, Timmis, "Specific-purpose plasmid cloning vectors. II. Broad host range, high copy number, RSF1010-derived vectors, and a host-vector system for gene cloning in *Pseudomonas*," *Gene*, 16(1-3):237-247, 1981.
- Baker *et al.*, "Evaluation of an immunoisolation membrane formed by incorporating a polyvinyl alcohol hydrogel within a microporous support," *Cell Transplantation*, 6(6):585-595, 1997.
- Balaguer *et al.*, "Reporter cell lines to study the estrogenic effects of xenoestrogens," *Sci. Total. Environ.*, 233(1-3):47-56, 1999.
- Bantle and Thomas, "Glucose measurement in patients with diabetes mellitus with dermal interstitial fluid," *J. Lab. Clin. Med.*, 130(4):436-441, 1997.
- Biondi, Baehler, Reymond, Veron, "Random insertion of GFP into the CAMP-dependent protein kinase regulatory subunit from *Dictyostelium discoideum*," *Nucleic Acids Res.*, 26:4946-52, 1998.
- Boonyaratanakornkit *et al.*, "Progesterone stimulation of human insulin-like growth factor-binding protein-5 gene transcription in human osteoblasts is mediated by a CACCC sequence in the proximal promoter," *J. Biol. Chem.*, 274(37):26431-8, 1999.

- Borgese, Aggujaro, Carrera, Pietrini, Bassetti, "A role for *N*-myristoylation in protein targeting: NADH-cytochrome b5 reductase requires myristic acid for association with outer mitochondrial but not ER membranes," *J. Cell Biol.*, 135:1501-1513, 1996.
- 5 Boundy *et al.*, "Regulation of tyrosine hydroxylase promoter activity by chronic morphine in TH9.0-LacZ transgenic mice," *J. Neurosci.*, 18(23):9989-95, 1998.
- Brand, Holtzman, Scher, Ausiello, Stow, "Role of myristoylation in membrane attachment and function of $G\alpha_{i-3}$ on golgi membranes," *Am. J. Physiol.*, 96:C1362-C1369, 1996.
- 10 Burczak, Gamian, Kochman, "Long-term *in vivo* performance and biocompatibility of poly(vinyl alcohol) hydrogel macrocapsules for hybrid-type artificial pancreas," *Biomaterials*, 17(24):2351-2356, 1996.
- Campanella, Aturki, Sammartino, Tomassetti, "Aspartate analysis in formulations using a new enzyme sensor," *J. Pharm. Biomed. Anal.*, 13:439-47, 1995.
- 15 Campbell *et al.*, "Regulation of the CYP1A1 promoter in transgenic mice: an exquisitely sensitive on-off system for cell specific gene regulation," *J. Cell Sci.*, 109(Pt 11):2619-25, 1996.
- Cassidy, Lee, Trevors, "Environmental applications of immobilized cells: a review," *J. Ind. Microbiol.*, 16:79-101, 1996.
- 20 Cebolla, Vazquez and Palomares, "Expression vectors for the use of eukaryotic luciferases as bacterial markers with different colors of luminescence," *Appl. Environ. Microbiol.*, 61:660-668, 1995.
- Coffey, Hawkey, Damstrup, Graves-Deal, Daniel, Dempsey, Chinery, Kirkland, DuBois, Jetton and Morrow, "Epidermal growth factor receptor activation induces nuclear targeting of cyclooxygenase-2, basolateral release of prostaglandins, and mitogenesis in polarizing colon cancer cells," *Proc. Natl. Acad. Sci. USA*, 94:657-562, 1997.
- 25 Coppola and Karl, "Pathology of early colonic neoplasia: clinical and pathologic features of precursor lesions and minimal carcinomas," *JMCC*, 4:160-166, 1998.
- 30 Demirpence, Duchesne, Badia, Gagne, Pons, "MVLN cells: a bioluminescent MCF-7-derived cell line to study the modulation of estrogenic activity," *J. Steroid Biochem. Molec. Biol.*, 46:355-364, 1995.

- Doiron, Cuif, Chen, Kahn, "Transcriptional glucose signaling through the glucose response element is mediated by the pentose phosphate pathway," *J. Biol. Chem.*, 271(10):5321-5324, 1996.
- Dupriez and Rousseau, "Glucose response elements in a gene that codes for 6-phosphofructo-2-kinase/fructose-2,6-bisphosphatase." *DNA Cell Biol.*, 16(9):1075-1085, 1997.
- Edenberg *et al.*, "Polymorphism of the human alcohol dehydrogenase 4 (ADH4) promoter affects gene expression," *Pharmacogenetics*, 9(1):25-30, 1999.
- Feng, Filvaroff and Derynck, "Transforming growth factor- (TGF-) induced down-regulation of cyclin A expression requires a functional TGF- receptor complex. Characterization of chimeric and truncated type I and type II receptors," *J. Biol. Chem.*, 270:24237-24245, 1995.
- Filatov, Bjorklund, Johansson, Thelander, "Induction of the mouse ribonucleotide reductase R1 and R2 genes in response to DNA damage to UV light," *J. Biol. Chem.*, 271:23698-23704, 1996.
- Foufelle, Gouhot, Pegorier, Perdereau, Girard, Ferre, "Glucose stimulation of lipogenic enzyme gene expression in cultured white adipose tissue. A role for glucose 6-phosphate," *J. Biol. Chem.*, 267(29):20543-20546, 1992.
- Gagne, Balaguer, Demirpence, Chabret, Trousse, Nicolas, Pons, "Stable luciferase transfected cells for studying steroid receptor biological activity," *J. Biol. Chem.*, 9:201-209, 1994.
- Gastaldelli, Schwarz, Cavegion, Traber, Traber, Rosenblatt, Toffolo, Cobelli, Wolfe, "Glucose kinetics in interstitial fluid can be predicted by compartmental modeling," *Am. J. Physiol.*, 272(3-1):E494-505, 1997.
- German and Wang, "The insulin gene contains multiple transcriptional elements that respond to glucose," *Mol. Cell. Biol.*, 14(6):4067-4075, 1994.
- German, Moss, Rutter, "Regulation of insulin gene expression by glucose and calcium in transfected primary islet cultures," *J. Biol. Chem.*, 265:22063-22066, 1990.
- Girard, Ferre, Foufelle, "Mechanisms by which carbohydrates regulate expression of genes for glycolytic and lipogenic enzymes," *Annu. Rev. Nutr.*, 17:325-352, 1997.
- Gough, Armour, Baker. "Advances and prospects in glucose assay technology," *Diabetologia*, 40:S102-S107, 1997.

- Gram, Nielson, Hansen, "Spontaneously silencing of humanized green fluorescent portien (hGFP) gene expression from a retroviral vector by DNA methylation," *J. Hematother*, 7:333-41, 1998.
- 5 Grygorczyk, Feighner, Adam, Liu, LeCouter, Dashkevicz, Hreniuk, Rydberg, Arena, "Detection of intracellular calcium elevations in *Xenopus lavis* oocytes: aequorin luminescence versus electrophysiology," *J. Neurosci. Methods*, 67:19-25, 1996.
- Gu, Inoue, Shinohara, Doi, Kogire, Aung, Sumi, Imamura, Fujisato, Maetani, "Xenotransplantation of bioartificial pancreas using a mesh-reinforced polyvinyl alcohol bag," *Cell Transplant.*, 3(1):S19-S21, 1994.
- 10 Gupta and Goldwasser, "The role of the near upstream sequence in hypoxia-induced expression of the erythropoietin gene," *Nucleic Acids Res.*, 24:4768-4774, 1996.
- Hanakam, Albrecht, Eckerskorn, Matzner, Gerisch, "Myristoylated and non-myristoylated forms of the pH sensor protein hisactophilin II: intracellular shuttling to plasma membrane and nucleus monitored in real time by a fusion with green fluorescent protein," *EMBO J.*, 15:2935-43, 1996.
- 15 Hastings, "Chemistries and colors of bioluminescent reactions: a review," *Gene*, 173:5-11, 1996.
- Hay, Applegate, Bright and Sayler, "A bioluminescent whole-cell reporter for the detection of 2,4-dichlorophenoxyacetic acid," *Appl. and Env. Microbiol.*, XX:XXX-XXX, 2000.
- 20 Hoffman, Sharma, Zhu, Ziyadeh, "Transcriptional activation of transforming growth factor-beta 1 in mesangial cell culture by high glucose concentration," *Kidney Int.*, 54(4):1107-1116, 1998.
- Ilyas, Tomlinson, Rowan. Pignatelli and Bodmer, " β -Catenin mutations in cell lines established from human colorectal cancers," *Proc. Natl. Acad. Sci. USA*, 94:10330-10334, 1997.
- 25 Inoue *et al.*, "Experimental hybrid islet transplantation: application of polyvinyl alcohol membranes for entrapment of islets," *Pancreas*, 7(5):562-568, 1992.
- Jiricny, J, "Replication errors: challenging the genome," *EMBO J.*, 17: 6427-6436, 1998.
- 30 Karran, "Microsatellite instability and DNA mismatch repair in human cancer," *Sem. Cancer Biol.*, 7:15-24, 1996.

- Kennedy, Viollet, Rafiq, Kahn, Rutter, "Upstream stimulatory factor-2 (USF2) activity is required for glucose stimulation of L-pyruvate kinase promoter activity in single living islet β -cells," *J. Biol. Chem.*, 272:20636-20640, 1997.
- King, DiGrazia, Applegate, Burlage, Sanseverino, Dunbar, Larimer and Sayler, "Rapid, sensitive bioluminescent reporter technology for naphthalene exposure and biodegradation," *Science*, 249:778-781, 1990.
- Kinzler and Vogelstein, "Lessons from hereditary colorectal cancer," *Cell*, 87:159-170, 1996.
- Kricka, "Chemiluminescence and bioluminescence," *Anal. Chem.*, 65:460R-462R, 1993.
- Ksander, "Collagen coatings reduce the incidence of capsule contracture around soft silicone rubber implants in animals," *Ann. Plast. Surg.*, 20(3):215-224, 1988.
- Kutchera, Jones, Matsunami, Groden, McIntyre, Zimmerman, White and Prescott, "Prostaglandin H synthase 2 is expressed abnormally in human colon cancer: evidence for a transcriptional effect," *Proc. Nat'l Acad. Sci. USA*, 93:4816-4820, 1996.
- Laiho, Saksela and Keski-Oja, "Transforming growth factor- induction of type-1 plasminogen activator inhibitor," *J. Biol. Chem.*, 262:17467-17474, 1987.
- Larger, Von Lucadou, Preidel, Ruprecht, Saeger, "Electrocatalytic glucose sensor," *Med. Biol. Eng. Comput.* 32:247-52, 1994.
- Layton, Muccini, Ghosh, Sayler, "Construction of a bioluminescent reporter strain to detect polychlorinated biphenyls," *App. Environ. Microbiol.*, In Press.
- Lengauer, Kinzler and Vogelstein, "Genetic instabilities in human cancers," *Nature*, 396:643-649, 1998.
- Levy, Muldoon, Zolotukin, Link, "Retroviral transfer and expression of a humanized, red-shifted green fluorescent protein gene into human tumor cells," *Nat. Biotechnol.*, 14:610-4, 1996.
- Malik, Beyersdorf-Radeck, Schmid, "Preservation of immobilized bacterial cell-matrix by drying for direct use in microbial sensors," *World J. Microbiol. Biotechnol.*, 9:243-247, 1993.
- Markowitz, Wang, Myeroff, Parsons, Sun, Lutterbaugh, Fan, Zborowska, Kinzler, Vogelstein, Brattain and Willson, "Inactivation of the type II TGF- β receptor in colon cancer cells with microsatellite instability," *Science*, 268:1336-1338, 1995.

- Marois, Chakfe, Guidoin, Duhamel, Roy, Marois, King, Douville, "An albumin-coated polyester arterial graft: *in vivo* assessment of biocompatibility and healing characteristics," *Biomaterials*, 17(1):3-14, 1996.
- Meighen, "Molecular biology of bacterial bioluminescence," *Microbiol. Rev.*, 55:123-142, 1991.
- 5 Monaco A.P. 1993. Transplantation of pancreatic islets with immunoexclusion membranes. *Transplant Proc.* 25(3) 2234-2236.
- Morin, Sparks, Korinek, Barker, Clevers, Vogelstein and Kinzler, "Activation of β -catenin-Tcf signaling in colon cancer by mutations in β -catenin or APC," *Science*, 10 275:1787-1790, 1997.
- Morin, Vogelstein and Kinzler, "Apoptosis and APC in colorectal tumorigenesis," *Proc. Natl. Acad. Sci. USA*, 93:7950-7954, 1996.
- Moussy, Jakeway, Harrison, Rajotte, "In vitro and in vivo performance and lifetime of perfluorinated ionomer-coated glucose sensors after high-temperature curing," 15 *Anal. Chem.*, 66(22):3882-3888, 1994.
- Müller, Choidas, Reichmann and Ullrich, "Phosphorylation and free pool of β -catenin are regulated by tyrosine kinases and tyrosine phosphatases during epithelial cell migration," *J. Biol. Chem.*, 274:10173-10173, 1999.
- Munemitsu, Albert, Rubenfield and Polakis, "Deletion of an amino-terminal sequence 20 stabilizes β -catenin in vivo and promotes hyperphosphorylation of the adenomatous polyposis coli tumor suppressor protein," *Mol. Cell Biol.*, 16:4088-4094, 1996.
- Neufeld and White, "Nuclear and cytoplasmic localizations of the adenomatous polyposis coli protein," *Proc. Natl. Acad. Sci. USA*, 94:3034-3039, 1997.
- Nicolaidis, Papadopoulos, Liu, Wei, Carter, Ruben, Rosen, Haseltine, Fleischmann, 25 Fraser, Adams, Venter, Dunlop, Hamilton, Peterson, de la Chapelle, Vogelstein and Kinzler, "Mutations in two PMS homologues in hereditary nonpolyposis colon cancer," *Nature*, 371:75-80, 1994.
- Ohara, Dorit, Gilbert, "One-sided polymerase chain reaction: the amplification of cDNA," *Proc. Natl. Acad. Sci. USA*, 86(15):5673-5677, 1989.
- 30 Ohgawara, Hirotani, Miyazaki, Teraoka, "Membrane immunoisolation of a diffusion chamber for bioartificial pancreas," *Artif. Organs*, 22(9):788-794, 1998.

- Olsen, DeBusscher, McCombie, "Development of broad-host-range vectors and gene banks: self-cloning of the *Pseudomonas aeruginosa* PAO chromosome," *J. Bacteriol.*, 150(1):60-69, 1982.
- 5 Patzer, Yao, Xu, Day, Wolfson, Liu, "A microchip glucose sensor," *Am. Soc. Artif. Intern. Organs.*, 41:M409-M413, 1995.
- Petersen, D.D., M.A. Magnuson, and D.K. Granner. 1988. Location and characterization of two widely separated glucocorticoid response elements in the phosphoenolpyruvate carboxykinase gene. *Mol. Cell. Biol.* 8:96-104.
- 10 Poitout, Moatti-Sirat, Reach, Zhang, Wilson, Lemonnier, Klein, "A glucose monitoring system for on line estimation in man of blood glucose concentration using a miniaturized glucose sensor implanted in the subcutaneous tissue and a wearable control unit," *Diabetologia*, 36(7):658-663, 1993.
- Prasher, "Using GFP to see the light," *Trends Genet.*, 11:320-329, 1995.
- 15 Prevost PH, S. Flori, C. Collier, E. Muscat, and E. Rolland. 1997. Application of AN69 Hydrogel to islet encapsulation. *Ann NY Acad Sci* 831:344-349.
- Quinn, P.G., T.W. Wong, M.A. Magnuson, J.B. Shabb, and D.K. Granner. 1988. Identification of basal and cyclic AMP regulatory elements in the promoter of the phosphoenolpyruvate carboxykinase gene. *Mol. Cell. Biol.* 8:3467-3475.
- 20 Ramanathan, Ensor, Daunert, "Bacterial biosensors for monitoring toxic metals," *Trends Biotech.* 15:16-22, 1997.
- Rubtsova, Kovba, Egorov. "Chemiluminescent biosensors based on porous supports with immobilized peroxidase," *Biosens. Bioelectron.*, 13:75-85, 1998.
- 25 Rudnick, Warren, McWherter, Toth, Machelski, Gordon, "Use of photoactivatable peptide substrates of *Saccharomyces cerevisiae* myristol-CoA-protein *N*-myristoyltransferase (Nmt1p) to characterize a myristol-CoA-Nmt1p-peptide ternary complex and to provide evidence for an ordered reaction mechanism," *Proc. Natl. Acad. Sci U.S.A.*, 90:1087-1091, 1993.
- Sambrook, Fritsch, Maniatis. *In: Molecular cloning: a laboratory manual*, 2d Ed. Cold Spring Harbor Laboratory Press, Plainview, NY, 1989.
- 30 Sasaki, K., T.P. Cripe, S.R. Koch, T.L. Andreone, D.D. Petersen, E.G. Beale, and D.K. Granner. 1984. Multihormonal regulation of phosphoenolpyruvate carboxykinase gene transcription. *J. Biol. Chem.* 259:15242-15251.

- Schmidt, Sluiter, Schoonen, "Glucose concentration in subcutaneous extracellular space," *Diabetes Care*, 16(5):695-700, 1993.
- Selam, "Management of diabetes with glucose sensors and implantable insulin pumps," *ASAIO J.*, 137-142, 1997.
- 5 Sheng, Shao, Kirkland, Isakson, Coffey, Morrow, Beauchamp and DuBois, "Inhibition of human colon cancer cell growth by selective inhibition of cyclooxygenase-2," *J. Clin. Invest.*, 99:2254-2259, 1999.
- Shibata, Toyama, Shioya, Ito, Hirota, Hasegawa, Matsumoto, Takano, Akiyama, Toyoshima, Kanamaru, Kanegae, Saito, Nakamura, Shiba and Noda, "Rapid colorectal adenoma formation initiated by conditional targeting of the *Apc* gene,"
- 10 *Science*, 278:120-123, 1997.
- Shih, Liu, Towle, "Two CACGTG motifs with proper spacing dictate the carbohydrate regulation of hepatic gene transcription," *J. Biol. Chem.*, 270(37):21991-21997, 1995.
- 15 Short, J.M., A. Wynshaw-Boris, H.P. Short, and R.W. Hanson. 1986. Characterization of the phosphoenolpyruvate carboxykinase (GTP) promoter-regulatory region. *J. Biol. Chem.* 261:9721-9726.
- Siegal and Isacoff, "A genetically encoded optical probe of membrane voltage," *Neuron*, 19:735-41, 1997.
- 20 Simpson, Ericson, Jellison, Dress, Sitter, Wintenberg and French, "A Photo-Spectrometer Realized in a Standard CMOS IC Process," *Rev. of Sci. Instr.*, 69(2):377-383, Feb. 1998.
- Simpson, Jellison, Ericson, Dress, Wintenberg and Bobrek, "Application Specific Spectral Response with CMOS Compatible Photodiodes," to be published *IEEE Trans. Elect. Dev.*, May 1999.
- 25 Simpson, Paulus, Jellison, Sayler, Applegate, Ripp, Nivens, "Bioluminescent bioreporter integrated circuits (BBICs): whole-cell chemical biosensors," *Technical Digest of 1998 Solid-State Sensors and Actuators Conference*, Hilton Head Island, SC, pp 354-357, 1998b.
- 30 Simpson, Sayler, Applegate, Ripp, Nivens, Paulus and Jellison, "Bioluminescent Bioreporter Integrated Circuits (BBICs) Bioluminescent Bioreporter Integrated Circuits (BBICs): Whole-Cell Environmental Monitoring Devices," to be

presented at the 29th International Conference on Environmental Systems, July 15, 1999.

Simpson, Sayler, Ripp, Nivens, Applegate, Paulus and Jellison, "Bioluminescent-Bioreporter Integrated Circuits Form Novel Whole-Cell Biosensors," (invited)
5 *Trends in Biotechnology*, 16:332-338, August 1998.

Simpson, Sayler, Ripp, Paulus and Jellison, "Bioluminescent Bioreporter Integrated Circuits (BBICs)," *Smart Structures and Materials 1998: Smart Electronics and MEMS*, Varadan, McWhorter, Singer and Vellekoop (Eds.), Proceedings of SPIE, Vol. 3328, 202-212, 1998.

10 Smyrk, "Colon cancer connections. Cancer syndrome meets molecular biology meets histopathology," *Am. J. Pathol.*, 145:1-6, 1994.

Srikantha, Klapach, Lorenz, Tsai, Laughlin, Gorman, Soll, "The sea pansy *Renilla reniformis* luciferase serves as a sensitive bioluminescent reporter for differential gene expression in *Candida albicans*," *J. Bacteriol.*, 178:121-129, 1996.

15 Steinberg, Poziomek, Engelman, Rogers, "A review of environmental applications of bioluminescence measurements," *Chemosphere*, 30:2155-2197, 1995.

Sternberg, Bindra, Wilson, Thevenot, "Covalent enzyme coupling on cellulose acetate membranes for glucose sensor development," *Anal. Chem.*, 60(24):2781-2786, 1988.

20 Sternberg, Meyerhoff, Mennel, Bischof, Pfeiffer, "Subcutaneous glucose concentration in humans. Real estimation and continuous monitoring," *Diabetes Care*, 18(9):1266-1269, 1995.

Suzuki K., S. Bonner-Weir, J. Hollister-Lock, C.K. Colten, and GS Weir, "Number and volume of islets transplanted in immunobarrier devices," *Cell Transplant.*,
25 7(1):47-52, 1998.

Takaku, Oshima, Miyoshi, Matsui, Seldin and Taketo, "Intestinal tumorigenesis in compound mutant mice of both *Dpc4 (Smad4)* and *Apc* genes," *Cell*, 92:645-656, 1998.

Taniguchi, Fukao, Nakauchi, "Constant delivery of proinsulin by encapsulation of
30 transfected cells," *J. Surg. Res.*, 70(1):41-45, 1997.

Tu and Mager, "Biochemistry of bacterial bioluminescence," *Photochem. Photobiol.*, 62:615-624, 1995.

- Tziampazis and Sambanis, "Tissue engineering of a bioartificial pancreas: modeling the cell environment and device function," *Biotechnol. Prog.*, 11(2):115-126, 1995.
- Vaidya and Wilkins, "Application of polytetrafluoroethylene (PTFE) membranes to control interference effects in a glucose biosensor," *Biomed. Instrum. Technol.*, 5 27(6):486-494, 1993.
- Vaidya and Wilkins, "Use of charged membranes to control interference by body chemicals in a glucose biosensor," *Med. Eng. Phys.*, 16(5):416-421, 1994.
- Wallace, Fleming, White and Saylor, "An *algD*-bioluminescent reporter plasmid to monitor alginate expression in biofilms," *Microb. Ecol.*, 27:224-240, 1994.
- 10 Wang, Ji, Yuan, "Study of cellulose acetate membrane-based glucose biosensors," *Chin. J. Biotechnol.*, 11(3):199-205, 1995.
- Wang, Sun, Myeroff, Wang, Gentry, Yang, Liang, Zborowska, Markowitz, Willson and Brattain, "Demonstration that mutation of the type II transforming growth factor receptor inactivates its tumor suppressor activity in replication error-positive colon carcinoma cells," *J. Biol. Chem.*, 270:22044-22049, 1995.
- 15 Ward, Wilgus, Troupe, "Rapid detection of hyperglycaemia by a subcutaneously-implanted glucose sensor in the rat," *Biosens. Bioelectron.*, 9(6):423-428, 1994.
- Wilkins, Atanasov, Muggenburg, "Integrated implantable device for long-term glucose monitoring," *Biosens. Bioelectron.*, 10:485-494, 1995.
- 20 Wolfson, Tokarsky, Yao, Krupper, "Glucose concentration at possible sensor tissue implant sites," *Diabetes Care*, 5(3):162-165, 1982.
- Wu, Storrier, Pariente, Wang, Shapleigh, Abruna, "A nitrate biosensor based on a maltose binding protein nitrite reductase fusion immobilized on an electropolymerized film of a pyrrole-derived bipyridinium," *Anal. Chem.* 69:4856-63, 1997.
- 25 Yao, Xu, Day, Patzer, "Interference of amino acids on glucose sensing," *Am. Soc. Artif. Intern. Organs J.*, 40:33-40, 1994.
- Young, Yao, Chang, Chen, "Evaluation of asymmetric poly(vinyl alcohol) membranes for use in artificial islets," *Biomaterials*, 17(22):2139-2145, 1996.
- Zhu, Richardson, Parada and Graff, "*Smad3* mutant mice develop metastatic colorectal cancer," *Cell*, 94:703-714, 1998.
- 30

Zolotukhin, Potter, Hauswirth, Guy, Muzyczka, "A 'humanized' green fluorescent protein cDNA adapted for high-level expression in mamalian cells," *J. Virol.* 70:4646-54, 1996.

5 Zondervan, Hoppen, Pennings, Fritschy, Wolters, van Schilfgaarde, "Design of a polyurethane membrane for the encapsulation of islets of Langerhans," *Biomaterials*, 13(3):136-144, 1992.

All of the compositions, methods, devices, apparatus and systems disclosed and claimed herein can be made and executed without undue experimentation in light of the present disclosure. While the methods, devices, apparatus and systems of this invention
10 have been described in terms of preferred embodiments, it will be apparent to those of skill in the art that variations may be applied to the methods, devices, apparatus and systems and in the steps or in the sequence of steps of the methods described herein without departing from the concept, spirit and scope of the invention. More specifically,
15 it will be apparent that certain agents which are both chemically and physiologically related may be substituted for the agents described herein while the same or similar results would be achieved. All such similar substitutes and modifications apparent to those skilled in the art are deemed to be within the spirit, scope and concept of the invention as defined by the appended claims. Accordingly, the exclusive rights sought to be patented
20 are as described in the claims below.

CLAIMS:

1. An implantable monolithic bioelectronic device for detecting an analyte within the
5 body of an animal, said device comprising:

(a) a bioreporter atop a substrate on an integrated circuit, said bioreporter
being capable of metabolizing said analyte and emitting light consequent to such
metabolism when in contact with said analyte; and,

10 (b) a sensor closely positioned to said integrated circuit that generates an
electrical signal in response to receiving said emitted light,

wherein said device is contained within a biocompatible container that is implanted within
15 the body of said animal.

2. The implantable monolithic bioelectronic device of claim 1, wherein said
biocompatible container comprises a polymeric matrix.

3. The implantable monolithic bioelectronic device of claim 2, wherein said
polymeric matrix comprises polyvinyl alcohol, poly-L-lysine, or alginate.

4. The implantable monolithic bioelectronic device of claim 2, wherein said
polymeric matrix further comprises a microporous, mesh-reinforced or filter-
supported hydrogel.

5. The implantable monolithic bioelectronic device of claim 1, wherein said
integrated circuit comprises a phototransducer.

- 5 6. The implantable monolithic bioelectronic device of claim 5, further comprising a transparent, biocompatible, bioresistant separator operably positioned between the phototransducer and the bioreporter.
- 10 7. The implantable monolithic bioelectronic device of claim 1, wherein said bioreporter comprises a plurality of eukaryotic or prokaryotic cells that produce a bioluminescent reporter polypeptide in response to the presence of said analyte.
- 15 8. The implantable monolithic bioelectronic device of claim 7, wherein said plurality of prokaryotic cells comprise bacteria.
- 20 9. The implantable monolithic bioelectronic device of claim 7, wherein said plurality of eukaryotic cells comprise mammalian cells.
- 25 10. The implantable monolithic bioelectronic device of claim 9, wherein said plurality of eukaryotic cells comprise islet β -cells, immortal stem cells, or hepatic cells.
- 30 11. The implantable monolithic bioelectronic device of claim 10, wherein said plurality of eukaryotic cells comprise recombinant human immortal stem cells.
12. The implantable monolithic bioelectronic device of claim 7, wherein said plurality of cells comprise a nucleic acid segment that encodes a luciferase polypeptide or a green fluorescent protein that is produced by said cells in response to the presence of said analyte.

- 5
13. The implantable monolithic bioelectronic device of claim 12, wherein said nucleic acid segment encodes an *Aqueorea victoria* or a *Renilla reniformis* green fluorescent protein.
- 10
14. The implantable monolithic bioelectronic device of claim 12, wherein said nucleic acid segment encodes a humanized green fluorescent protein.
- 15
15. The implantable monolithic bioelectronic device of claim 12, wherein said nucleic acid segment encodes a bacterial Lux polypeptide.
- 16
16. The implantable monolithic bioelectronic device of claim 15, wherein said nucleic acid segment encodes a bacterial LuxA, LuxB, LuxC, LuxD, or LuxE polypeptide, or a LuxAB, or LuxCDE fused polypeptide.
- 20
17. The implantable monolithic bioelectronic device of claim 16, wherein said nucleic acid segment encodes a *Vibrio fischerii* or a *Xenorhabdus luminescens* LuxA, LuxB, LuxC, LuxD, or LuxE polypeptide, or a LuxAB, or LuxCDE fused polypeptide.
- 25
18. The implantable monolithic bioelectronic device of claim 17, wherein said nucleic acid encodes a *Xenorhabdus luminescens* LuxA, LuxB, LuxC, LuxD, or LuxE polypeptide, or a LuxAB, or LuxCDE fused polypeptide.
- 30

19. The implantable monolithic bioelectronic device of claim 18, wherein said polypeptide is encoded by a sequence comprising at least 25 contiguous nucleotides from SEQ ID NO:1.

5

20. The implantable monolithic bioelectronic device of claim 19, wherein said polypeptide is encoded by a sequence comprising at least 30 contiguous nucleotides from SEQ ID NO:1.

10

21. The implantable monolithic bioelectronic device of claim 20, wherein said polypeptide is encoded by a sequence comprising at least 35 contiguous nucleotides from SEQ ID NO:1.

15

22. The implantable monolithic bioelectronic device of claim 16, wherein the expression of said nucleic acid segment is regulated by a nucleic acid sequence comprising a *cis*-acting element that is responsive to the presence of said analyte.

20

23. The implantable monolithic bioelectronic device of claim 22, wherein said *cis*-acting response element is a nucleotide sequence selected from the group consisting of an S14 gene sequence, a hepatic L-pyruvate kinase gene sequence, a hepatic 6-phosphofructo-2-kinase gene sequence, a β -islets insulin gene sequence, a mesangial transforming growth factor- β gene sequence, and an acetyl-coenzyme-A carboxylase gene sequence.

25

24. The implantable monolithic bioelectronic device of claim 23, wherein said *cis*-acting response element comprises a contiguous nucleotide sequence from a β -islets insulin gene sequence or a hepatic L-pyruvate kinase gene sequence.

30

25. The implantable monolithic bioelectronic device of claim 12, wherein expression of said nucleic acid sequence is regulated by a promoter sequence derived from an L-pyruvate kinase-encoding gene.

5

26. The implantable monolithic bioelectronic device of claim 1, wherein said analyte is glucose, glucagon or insulin.

10

27. The implantable monolithic bioelectronic device of claim 7, further comprising a source of nutrients capable of sustaining said cells.

15

28. The implantable monolithic bioelectronic device of claim 1, further comprising a wireless transmitter.

20

29. The implantable monolithic bioelectronic device of claim 1, further comprising an antenna.

25

30. The implantable monolithic bioelectronic device of claim 1, further comprising an implantable drug delivery pump capable of being controlled by said device, and capable of delivering said drug to the body of said animal.

30

31. The implantable monolithic bioelectronic device of claim 1, wherein said biocompatible container further comprises a membrane that is permeable to said analyte but not to said bioreporter.

32. The implantable monolithic bioelectronic device of claim 1, wherein said bioreporter expresses said light-emitting polypeptide following the metabolism of said analyte by said bioreporter.
- 5
33. The implantable monolithic bioelectronic device of claim 2, wherein said biocompatible container comprises silicon nitride or silicon oxide.
- 10
34. The implantable monolithic bioelectronic device of claim 1, wherein said integrated circuit is a complementary metal oxide semiconductor (CMOS) integrated circuit.
- 15
35. The implantable monolithic bioelectronic device of claim 5, wherein said phototransducer comprises a photodiode.
- 20
36. The implantable monolithic bioelectronic device of claim 1, wherein said integrated circuit further comprises a photodiode and a current to frequency converter.
- 25
37. The implantable monolithic bioelectronic device of claim 1, wherein said integrated circuit further comprises a current to frequency converter and a digital counter.
- 30
38. The implantable monolithic bioelectronic device of claim 1, further comprising a transmitter.

39. The implantable monolithic bioelectronic device of claim 38, wherein said transmitter is capable of transmitting digital data.
- 5 40. An implantable controlled drug delivery system, comprising the device of claim 1, and an implantable drug delivery pump capable of being operably controlled by said device.
- 10 41. A method of providing a controlled supply of a drug to a patient in need thereof, comprising implanting within the body of said patient the controlled drug delivery system of claim 40.
- 15 42. A method of determining the amount of a drug required by a patient in need thereof, comprising implanting within the body of said patient the device of claim 1, and determining the amount of drug required by said patient based upon the output from said device.
- 20 43. A kit for the detection of an analyte comprising the device of claim 1 and instructions for using said device.
- 25 44. The kit of claim 43, further comprising a standardized reference solution.
- 30 45. A method of regulating the blood glucose level of an animal in need thereof, comprising monitoring the level of glucose in the bloodstream or interstitial fluid of said patient using the device of claim 1 or the kit of claim 43, and administering

to said patient an effective amount of an insulin composition sufficient to regulate said blood glucose level.

1/8

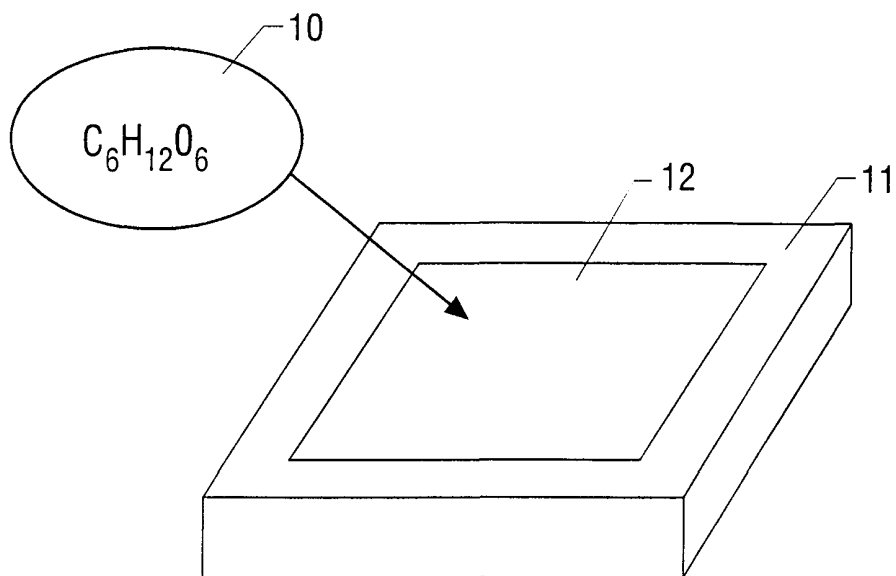

FIG. 1

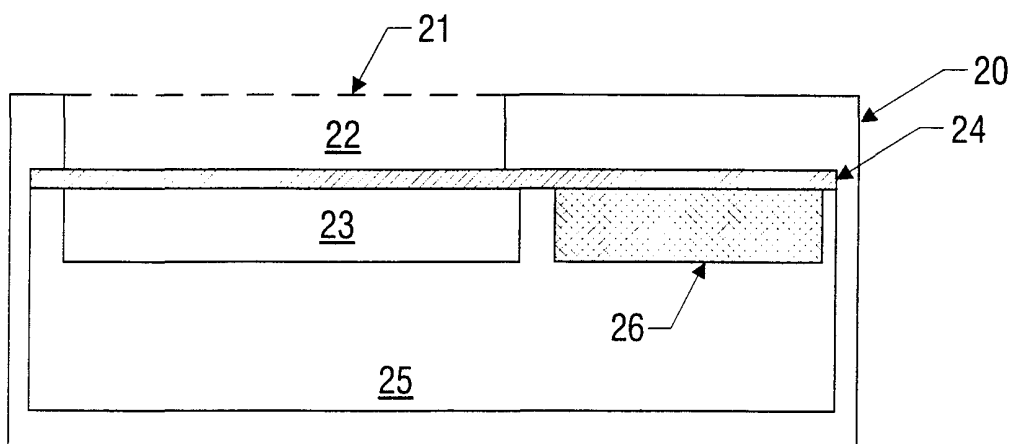

FIG. 2

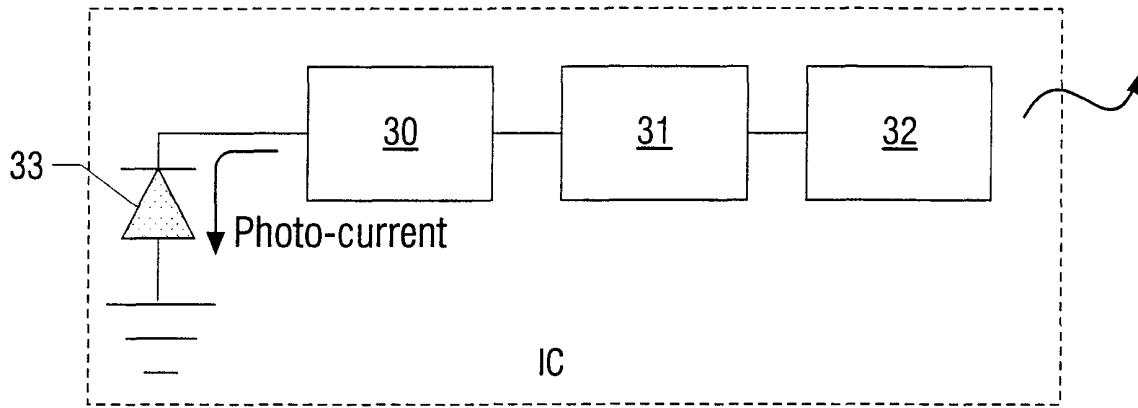

FIG. 3

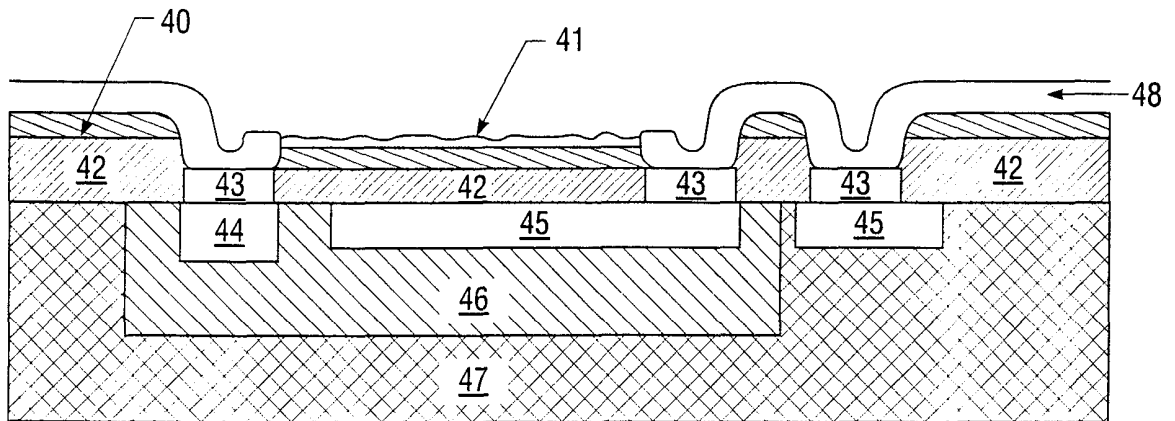

FIG. 4A

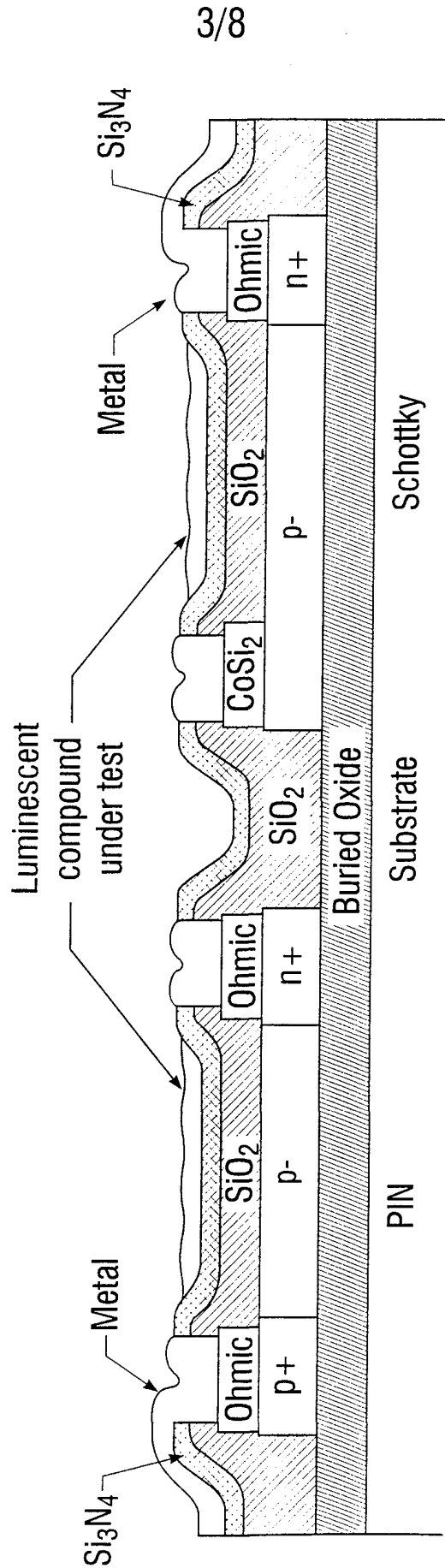

FIG. 4B

4/8

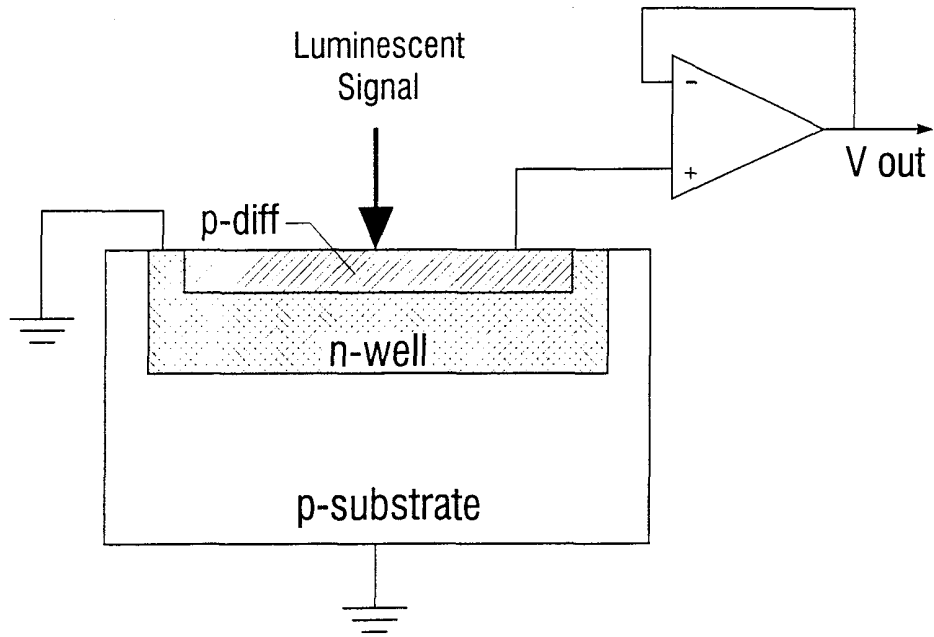

FIG. 5A

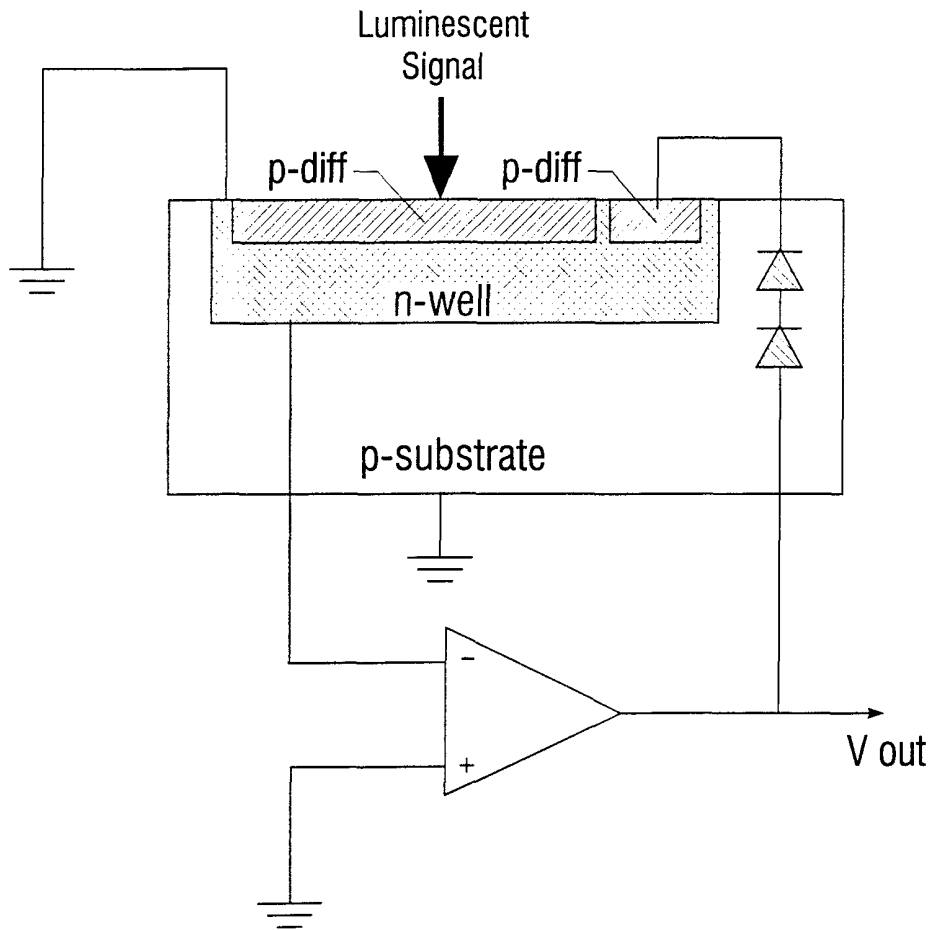

FIG. 5B

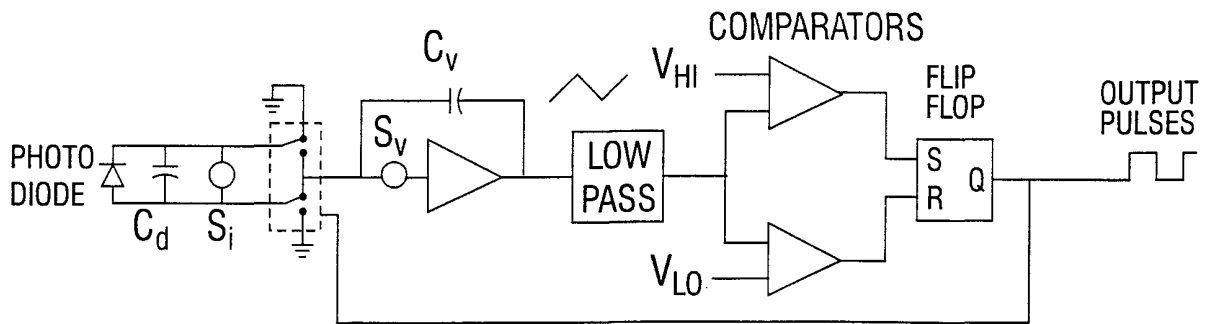

FIG. 5C

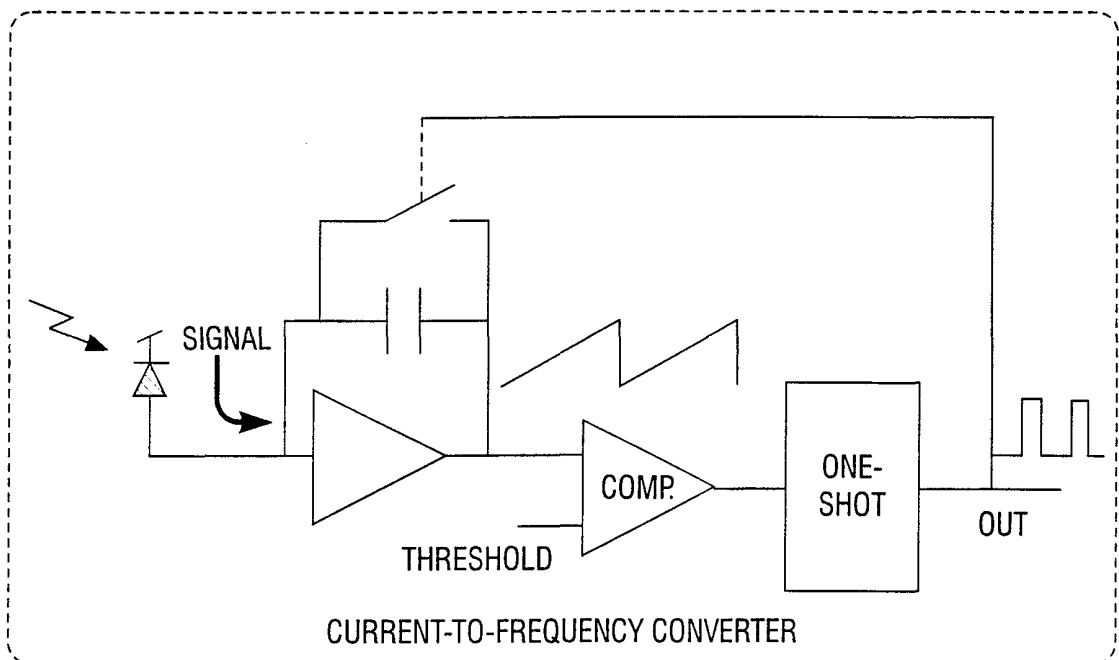
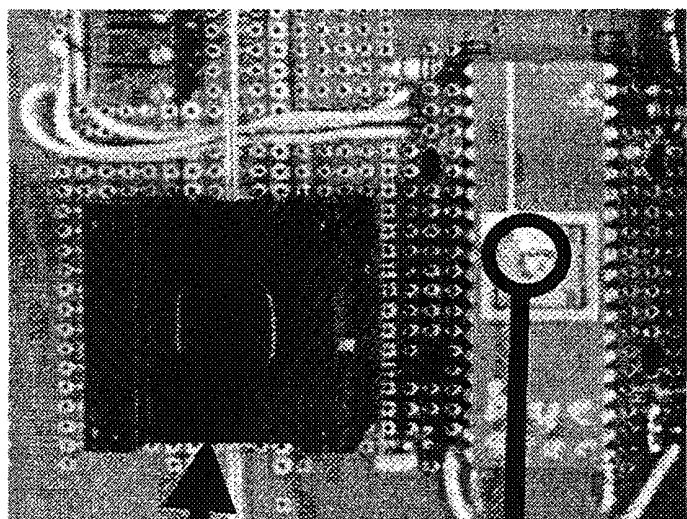

FIG. 6



BIOREPORTER
ENCLOSURE

MICROLUMINOMETER

FIG. 7

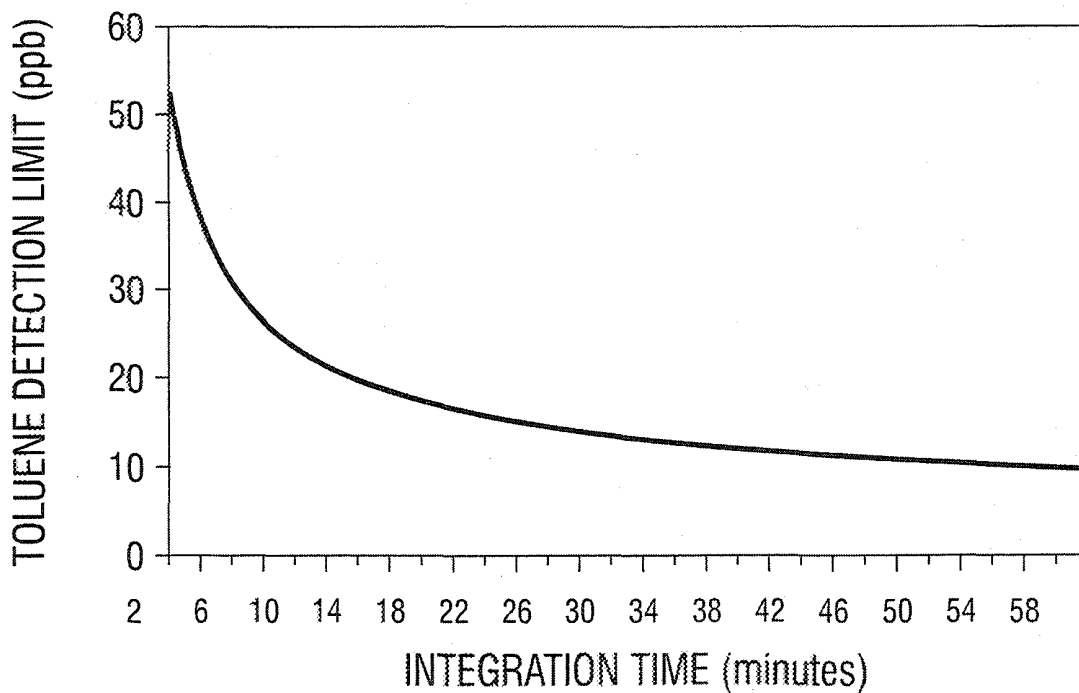

FIG. 8

7/8

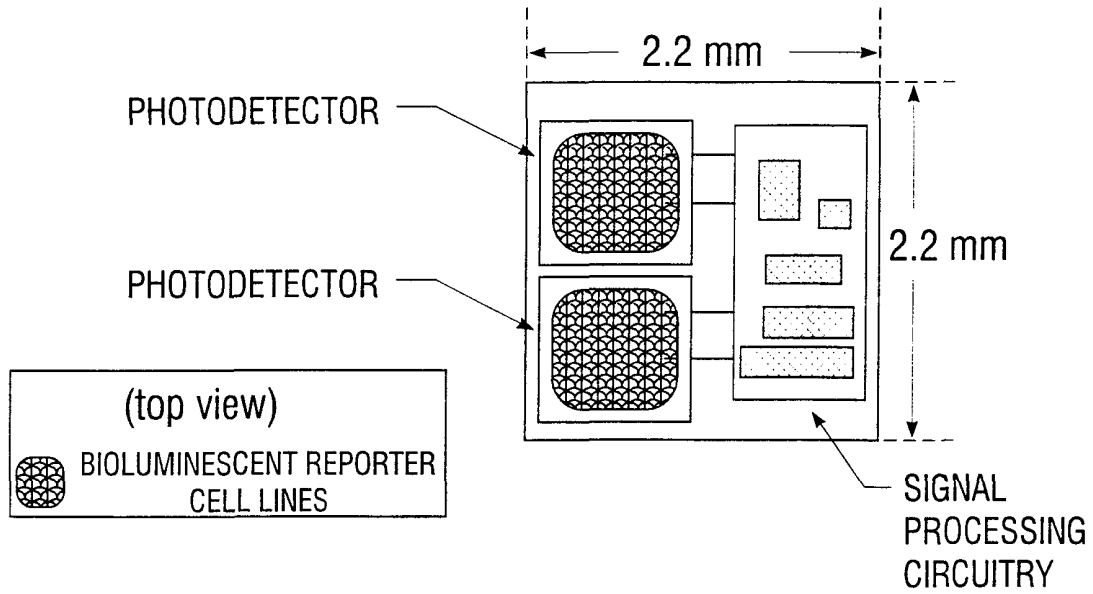

FIG. 9A

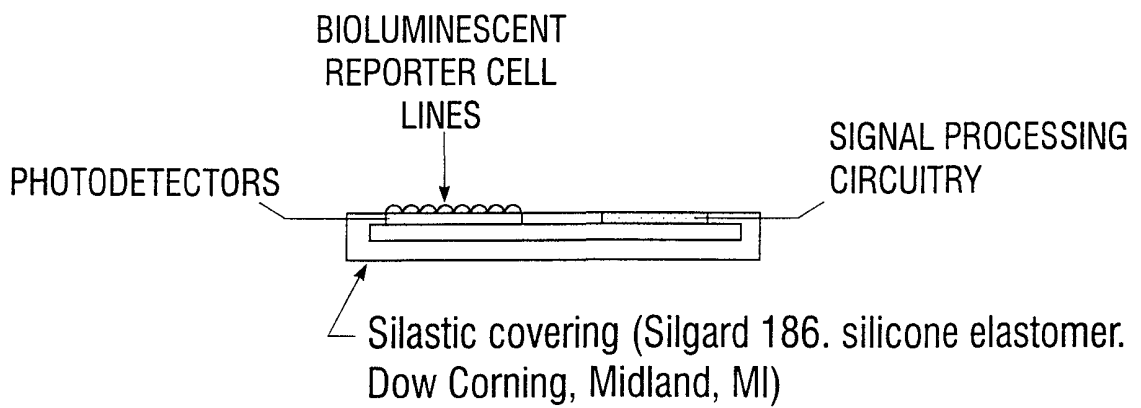

FIG. 9B

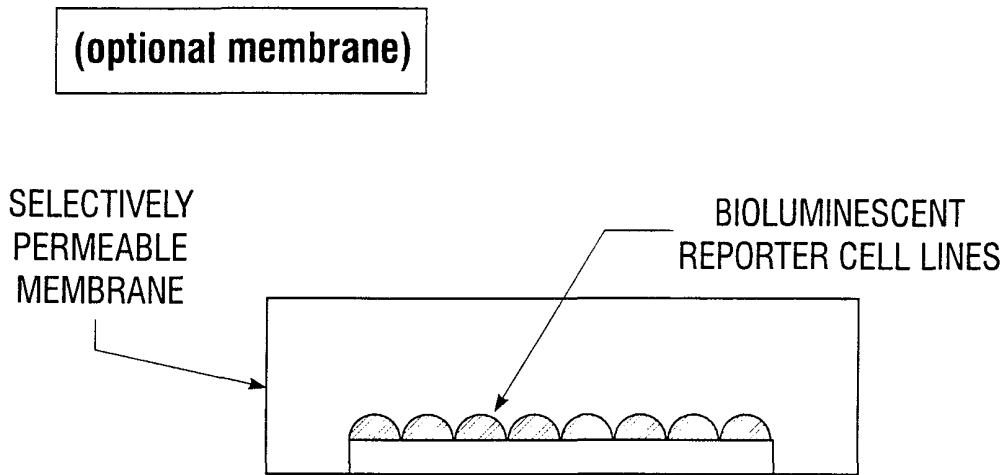

FIG. 9C

Subcutaneous Glucose Biosensor and Insulin Pump.

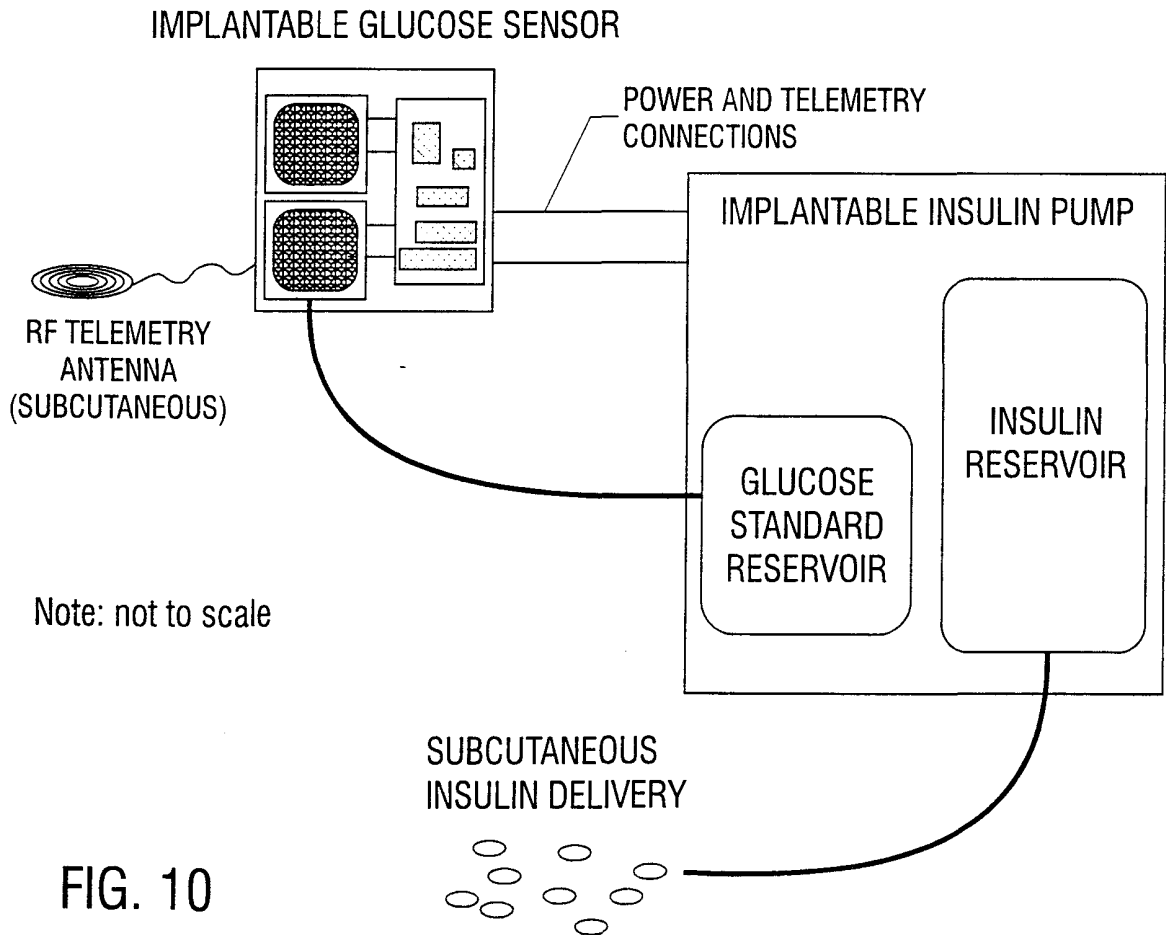

FIG. 10

SEQUENCE LISTING

<110> SAYLER, GARY S.
 SIMPSON, MICHAEL L.
 APPLGATE, BRUCE M.
 RIPP, STEVEN A.

<120> IN VIVO BIOSENSOR APPARATUS AND METHOD OF USE

<130> 4300.004300

<140> UNKNOWN

<141> 1999-12-02

<150> 60/110,684

<151> 1998-12-02

<160> 7

<170> PatentIn Ver. 2.0

<210> 1

<211> 7669

<212> DNA

<213> Xenorhabdus luminescens

<220>

<221> CDS

<222> (1215)..(2657)

<223> LUXC

<220>

<221> CDS

<222> (2671)..(3594)

<223> LUXD

<220>

<221> CDS

<222> (3776)..(4858)

<223> LUXA

<220>

<221> CDS

<222> (4873)..(5847)

<223> LUXB

<220>

<221> CDS

<222> (6160)..(7272)

<223> LUXE

<400> 1

gaattctcag actcaaatag aacaggattc taaagactta agagcagctg tagatcgtga 60

ttttagtacg atagagccaa cattgagaaa ttatggggca acggaagcac aacttgaaga 120

```

cgccagagcc aaaatacaca agcttaacca agaacagagg ttatacaaat gacagttaat 180
acagaggcac taataaacag cctaggcaag tctaccaag aaatttttga tgaagggcta 240
attccttata ggaataagcc aagtggttct cctgggggtgc ctaatatattg tattgacatg 300
gtgaaagagg ggattttttt gtogtttgaa cggaatagta aaatattaaa cgaaattact 360
ttaagattgc ttagagacga taaagctttg tttatatttc caaatgaatt gccatcaccg 420
ttgaagcatt ctatggatag gggatgggtt agagaaaatt tagtgatct gattaaatca 480
ataccaccga gacaaatfff aaaaaggcag tttggttgga aagatctata tcgttttacg 540
gatgaaatca gtatgcagat ttcttatgat ttacgtgaac aggttaatte agtgactttc 600
ttgcttacat cagacgtgag ttggtaatff aatatatata cccttcatoc ttcaagttgc 660
tgctttgttg gctgctttct ctcaccccag tcacatagtt atctatgctc ctggggattc 720
gttcacttgc cgccgcgctg caacttgaaa tctattgggt atatgctatt ggtaattatg 780
gaaaattgcc tgatttatat ataacttaac ttgtaaacca gataataatt tacatgaata 840
ttatcacgta taaaaaaatt gcgattctff taatttgaaa tagttcaatt taattgaaac 900
tttttattaa caaatcttgt tgatgtgaaa attttcgfff gctattffaa cagatattgt 960
taaacggaga aggcagcatg ttgatgattc actcagccag actgacagtt ttaagcggaa 1020
aattgcagag tatgatcgca ttctgataaa ggttacaggt cactcgcaac cagaatttca 1080
tctttgtata ttttgttttg ttatttacgt tgcagcaaga caaaaataga agaaacaaat 1140
atttatacaa cccgtttgca agagggttaa acagcaatff aagttgaaat tgccctatta 1200
aatggatggc aaat atg aac aaa aaa att tca ttc att att aac ggt cga 1250
                Met Asn Lys Lys Ile Ser Phe Ile Ile Asn Gly Arg
                1                5                10

gtt gaa ata ttt cct gaa agt gat gat tta gtg caa tcc att aat ttt 1298
Val Glu Ile Phe Pro Glu Ser Asp Asp Leu Val Gln Ser Ile Asn Phe
                15                20                25

ggg gat aat agt gtt cat ttg cca gta ttg aat gat tct caa gta aaa 1346
Gly Asp Asn Ser Val His Leu Pro Val Leu Asn Asp Ser Gln Val Lys
                30                35                40

aac att att gat tat aat gaa aat aat gaa ttg caa ttg cat aac att 1394
Asn Ile Ile Asp Tyr Asn Glu Asn Asn Glu Leu Gln Leu His Asn Ile
                45                50                55                60

atc aac ttt ctc tat acg gta ggg caa cga tgg aaa aat gaa gaa tat 1442
Ile Asn Phe Leu Tyr Thr Val Gly Gln Arg Trp Lys Asn Glu Glu Tyr
                65                70                75

tca aga cgc agg aca tat att cgt gat cta aaa aga tat atg gga tat 1490

```

Ser	Arg	Arg	Arg	Thr	Tyr	Ile	Arg	Asp	Leu	Lys	Arg	Tyr	Met	Gly	Tyr	
			80					85					90			
tca	gaa	gaa	atg	gct	aag	cta	gag	gcc	aac	tgg	ata	tct	atg	att	ttg	1538
Ser	Glu	Glu	Met	Ala	Lys	Leu	Glu	Ala	Asn	Trp	Ile	Ser	Met	Ile	Leu	
		95					100				105					
tgc	tct	aaa	ggt	ggc	ctt	tat	gat	ctt	gta	aaa	aat	gaa	ctt	ggt	tct	1586
Cys	Ser	Lys	Gly	Gly	Leu	Tyr	Asp	Leu	Val	Lys	Asn	Glu	Leu	Gly	Ser	
	110					115					120					
cgc	cat	att	atg	gat	gaa	tgg	cta	cct	cag	gat	gaa	agt	tat	att	aga	1634
Arg	His	Ile	Met	Asp	Glu	Trp	Leu	Pro	Gln	Asp	Glu	Ser	Tyr	Ile	Arg	
125					130					135					140	
gct	ttt	ccg	aaa	gga	aaa	tcc	gta	cat	ctg	ttg	acg	ggt	aat	gtg	cca	1682
Ala	Phe	Pro	Lys	Gly	Lys	Ser	Val	His	Leu	Leu	Thr	Gly	Asn	Val	Pro	
				145					150					155		
tta	tct	ggt	gtg	ctg	tct	ata	ttg	cgt	gca	att	tta	aca	aag	aat	caa	1730
Leu	Ser	Gly	Val	Leu	Ser	Ile	Leu	Arg	Ala	Ile	Leu	Thr	Lys	Asn	Gln	
			160					165					170			
tgc	att	ata	aaa	acc	tca	tca	act	gat	cct	ttt	acc	gct	aat	gca	tta	1778
Cys	Ile	Ile	Lys	Thr	Ser	Ser	Thr	Asp	Pro	Phe	Thr	Ala	Asn	Ala	Leu	
		175					180					185				
gcg	cta	agt	ttt	atc	gat	gtg	gac	cct	cat	cat	ccg	gta	acg	cgt	tct	1826
Ala	Leu	Ser	Phe	Ile	Asp	Val	Asp	Pro	His	His	Pro	Val	Thr	Arg	Ser	
	190					195					200					
ttg	tca	gtc	gta	tat	tgg	caa	cat	caa	ggc	gat	ata	tca	ctc	gca	aaa	1874
Leu	Ser	Val	Val	Tyr	Trp	Gln	His	Gln	Gly	Asp	Ile	Ser	Leu	Ala	Lys	
205					210					215					220	
gag	att	atg	caa	cat	gcg	gat	gtc	gtt	gtt	gct	tgg	gga	ggg	gaa	gat	1922
Glu	Ile	Met	Gln	His	Ala	Asp	Val	Val	Val	Ala	Trp	Gly	Gly	Glu	Asp	
				225					230					235		
gcg	att	aat	tgg	gct	gta	aag	cat	gca	cca	ccc	gat	att	gac	gtg	atg	1970
Ala	Ile	Asn	Trp	Ala	Val	Lys	His	Ala	Pro	Pro	Asp	Ile	Asp	Val	Met	
			240					245					250			
aag	ttt	ggt	cct	aaa	aag	agt	ttt	tgt	att	att	gat	aac	cct	gtt	gat	2018
Lys	Phe	Gly	Pro	Lys	Lys	Ser	Phe	Cys	Ile	Ile	Asp	Asn	Pro	Val	Asp	
		255					260					265				
tta	gta	tcc	gca	gct	aca	ggg	gcg	gct	cat	gat	gtt	tgt	ttt	tac	gat	2066
Leu	Val	Ser	Ala	Ala	Thr	Gly	Ala	Ala	His	Asp	Val	Cys	Phe	Tyr	Asp	
	270					275					280					
cag	caa	gct	tgt	ttt	tcc	acc	caa	aat	ata	tat	tac	atg	gga	agt	cat	2114
Gln	Gln	Ala	Cys	Phe	Ser	Thr	Gln	Asn	Ile	Tyr	Tyr	Met	Gly	Ser	His	
285					290					295					300	
tat	gaa	gag	ttt	aag	cta	gcg	ttg	ata	gaa	aaa	ttg	aac	tta	tat	gcg	2162
Tyr	Glu	Glu	Phe	Lys	Leu	Ala	Leu	Ile	Glu	Lys	Leu	Asn	Leu	Tyr	Ala	

	305		310		315	
cat ata tta cca aac acc aaa aaa gat ttt gat gaa aag gcg gcc tat						2210
His Ile Leu Pro Asn Thr Lys Lys Asp Phe Asp Glu Lys Ala Ala Tyr	320		325		330	
tcc tta gtt caa aaa gaa tgt tta ttt gct gga tta aaa gta gag gtt						2258
Ser Leu Val Gln Lys Glu Cys Leu Phe Ala Gly Leu Lys Val Glu Val	335		340		345	
gat gtt cat cag cgc tgg atg gtt att gag tca aat gcg ggt gta gaa						2306
Asp Val His Gln Arg Trp Met Val Ile Glu Ser Asn Ala Gly Val Glu	350		355		360	
cta aat caa cca ctt ggc aga tgt gtg tat ctt cat cac gtc gat aat						2354
Leu Asn Gln Pro Leu Gly Arg Cys Val Tyr Leu His His Val Asp Asn	365		370		375	380
att gag caa ata ttg cct tat gtg cga aaa aat aaa acg caa acc ata						2402
Ile Glu Gln Ile Leu Pro Tyr Val Arg Lys Asn Lys Thr Gln Thr Ile	385		390		395	
tct gtt ttt cct tgg gag gcc gcg ctt aag tat cga gac tta tta gca						2450
Ser Val Phe Pro Trp Glu Ala Ala Leu Lys Tyr Arg Asp Leu Leu Ala	400		405		410	
tta aaa ggt gca gaa agg att gta gaa gca gga atg aat aat ata ttt						2498
Leu Lys Gly Ala Glu Arg Ile Val Glu Ala Gly Met Asn Asn Ile Phe	415		420		425	
cgg gtt ggt ggt gct cat gat gga atg aga cct tta caa cga ttg gtg						2546
Arg Val Gly Gly Ala His Asp Gly Met Arg Pro Leu Gln Arg Leu Val	430		435		440	
aca tat att tcc cat gaa aga cca tcc cac tat act gct aaa gat gtt						2594
Thr Tyr Ile Ser His Glu Arg Pro Ser His Tyr Thr Ala Lys Asp Val	445		450		455	460
gcg gtc gaa ata gaa cag act cga ttc ctg gaa gaa gat aag ttc ctg						2642
Ala Val Glu Ile Glu Gln Thr Arg Phe Leu Glu Glu Asp Lys Phe Leu	465		470		475	
gta ttt gtc cca taa taggtaaaag aat atg gaa aat aaa tcc aga tat						2691
Val Phe Val Pro Met Glu Asn Lys Ser Arg Tyr	480				485	
aaa acc atc gac cat gtt att tgt gtt gaa gaa aat aga aaa att cat						2739
Lys Thr Ile Asp His Val Ile Cys Val Glu Glu Asn Arg Lys Ile His	490		495		500	
gtc tgg gag acg ctg cca aaa gaa aat agt cca aag aga aaa aat acc						2787
Val Trp Glu Thr Leu Pro Lys Glu Asn Ser Pro Lys Arg Lys Asn Thr	505		510		515	520
ctt att att gcg tcg ggt ttt gcc cgc agg atg gat cat ttt gcc ggt						2835
Leu Ile Ile Ala Ser Gly Phe Ala Arg Arg Met Asp His Phe Ala Gly	525		530		535	

ctg gca gag tat ttg tcg cag aat gga ttt cat gtg atc cgc tat gat	2883
Leu Ala Glu Tyr Leu Ser Gln Asn Gly Phe His Val Ile Arg Tyr Asp	
540 545 550	
tct ctt cac cac gtt gga ttg agt tca ggg aca att gat gaa ttt aca	2931
Ser Leu His His Val Gly Leu Ser Ser Gly Thr Ile Asp Glu Phe Thr	
555 560 565	
atg tcc ata gga aaa cag agt tta tta gca gtg gtt gat tgg tta aat	2979
Met Ser Ile Gly Lys Gln Ser Leu Leu Ala Val Val Asp Trp Leu Asn	
570 575 580	
aca cga aaa ata aat aac ctc ggt atg ctg gct tca agc tta tct gcg	3027
Thr Arg Lys Ile Asn Asn Leu Gly Met Leu Ala Ser Ser Leu Ser Ala	
585 590 595 600	
cgg ata gct tat gca agt cta tct gaa att aat gtc tcg ttt tta att	3075
Arg Ile Ala Tyr Ala Ser Leu Ser Glu Ile Asn Val Ser Phe Leu Ile	
605 610 615	
acc gca gtc ggt gtg gtt aac tta aga tat act ctc gaa aga gct tta	3123
Thr Ala Val Gly Val Val Asn Leu Arg Tyr Thr Leu Glu Arg Ala Leu	
620 625 630	
gga ttt gat tat ctc agc tta cct att gat gaa ttg cca gat aat tta	3171
Gly Phe Asp Tyr Leu Ser Leu Pro Ile Asp Glu Leu Pro Asp Asn Leu	
635 640 645	
gat ttt gaa ggt cat aaa ttg ggt gct gag gtt ttt gcg aga gat tgc	3219
Asp Phe Glu Gly His Lys Leu Gly Ala Glu Val Phe Ala Arg Asp Cys	
650 655 660	
ttt gat tct ggc tgg gaa gat tta act tct aca att aat agt atg atg	3267
Phe Asp Ser Gly Trp Glu Asp Leu Thr Ser Thr Ile Asn Ser Met Met	
665 670 675 680	
cat ctt gat ata ccg ttt att gct ttt act gca aat aat gac gat tgg	3315
His Leu Asp Ile Pro Phe Ile Ala Phe Thr Ala Asn Asn Asp Asp Trp	
685 690 695	
gta aag caa gat gaa gtt att aca tta cta tca agc atc cgt agt cat	3363
Val Lys Gln Asp Glu Val Ile Thr Leu Leu Ser Ser Ile Arg Ser His	
700 705 710	
caa tgt aag ata tat tct tta cta gga agc tca cat gat ttg ggt gag	3411
Gln Cys Lys Ile Tyr Ser Leu Leu Gly Ser Ser His Asp Leu Gly Glu	
715 720 725	
aac tta gtg gtc ctg cgc aat ttt tat caa tcg gtt acg aaa gcc gct	3459
Asn Leu Val Val Leu Arg Asn Phe Tyr Gln Ser Val Thr Lys Ala Ala	
730 735 740	
atc gcg atg gat aat ggt tgt ctg gat att gat gtc gat att att gag	3507
Ile Ala Met Asp Asn Gly Cys Leu Asp Ile Asp Val Asp Ile Ile Glu	
745 750 755 760	

ccg tca ttc gaa cat tta acc att gcg gca gtc aat gaa cgc cga atg 3555
 Pro Ser Phe Glu His Leu Thr Ile Ala Ala Val Asn Glu Arg Arg Met
 765 770 775

aaa att gag att gaa aat caa gtg att tcg ctg tct taa aacctataacc 3604
 Lys Ile Glu Ile Glu Asn Gln Val Ile Ser Leu Ser
 780 785

aatagatttc gagttgcagc gcggcggcaa gtgaacgcat tcccaggagc atagataact 3664
 ctgtgactgg ggtgcgtgaa agcagccaac aaagcagcaa cttgaaggat gaagggata 3724
 ttgggataga tagttaactc tatcactcaa atagaaatat aaggactctc t atg aaa 3781
 Met Lys
 790

ttt gga aac ttt ttg ctt aca tac caa ccc ccc caa ttt tct caa aca 3829
 Phe Gly Asn Phe Leu Leu Thr Tyr Gln Pro Pro Gln Phe Ser Gln Thr
 795 800 805

gag gta atg aaa cgg ttg gtt aaa tta ggt cgc atc tct gag gaa tgc 3877
 Glu Val Met Lys Arg Leu Val Lys Leu Gly Arg Ile Ser Glu Glu Cys
 810 815 820

ggt ttt gat acc gta tgg tta ctt gag cat cat ttc acg gag ttt ggt 3925
 Gly Phe Asp Thr Val Trp Leu Leu Glu His His Phe Thr Glu Phe Gly
 825 830 835

ttg ctt ggt aac cct tat gtg gct gct gct tat tta ctt ggc gca acc 3973
 Leu Leu Gly Asn Pro Tyr Val Ala Ala Ala Tyr Leu Leu Gly Ala Thr
 840 845 850 855

aag aaa ttg aat gta ggg act gcg gct att gtt ctc ccc acc gct cat 4021
 Lys Lys Leu Asn Val Gly Thr Ala Ala Ile Val Leu Pro Thr Ala His
 860 865 870

cca gtt cgc cag ctt gaa gag gtg aat ttg ttg gat caa atg tca aaa 4069
 Pro Val Arg Gln Leu Glu Glu Val Asn Leu Leu Asp Gln Met Ser Lys
 875 880 885

gga cga ttt cga ttt ggt att tgt cgg ggg ctt tac aat aaa gat ttt 4117
 Gly Arg Phe Arg Phe Gly Ile Cys Arg Gly Leu Tyr Asn Lys Asp Phe
 890 895 900

cgc gta ttt ggc aca gat atg aat aac agt cgt gcc tta atg gag tgt 4165
 Arg Val Phe Gly Thr Asp Met Asn Asn Ser Arg Ala Leu Met Glu Cys
 905 910 915

tgg tat aag ttg ata cga aat gga atg act gag gga tat atg gaa gct 4213
 Trp Tyr Lys Leu Ile Arg Asn Gly Met Thr Glu Gly Tyr Met Glu Ala
 920 925 930 935

gac aac gaa cat att aag ttc cat aag gta aaa gtg ctg ccg acg gca 4261
 Asp Asn Glu His Ile Lys Phe His Lys Val Lys Val Leu Pro Thr Ala
 940 945 950

tat agt caa ggt ggt gca cct att tat gtc gtt gct gaa tcc gct tcc 4309

Tyr Ser Gln Gly Gly Ala Pro Ile Tyr Val Val Ala Glu Ser Ala Ser	
955	960
965	
acg act gaa tgg gcc gct caa cat ggt tta ccg atg att tta agt tgg	4357
Thr Thr Glu Trp Ala Ala Gln His Gly Leu Pro Met Ile Leu Ser Trp	
970	975
980	
att ata aat act aac gaa aag aaa gca caa att gag ctt tat aac gag	4405
Ile Ile Asn Thr Asn Glu Lys Lys Ala Gln Ile Glu Leu Tyr Asn Glu	
985	990
995	
gtc gct caa gaa tat gga cac gat att cat aat atc gac cat tgc tta	4453
Val Ala Gln Glu Tyr Gly His Asp Ile His Asn Ile Asp His Cys Leu	
1000	1005
1010	1015
tca tat ata aca tcg gta gac cat gac tca atg aaa gcg aaa gaa att	4501
Ser Tyr Ile Thr Ser Val Asp His Asp Ser Met Lys Ala Lys Glu Ile	
1020	1025
1030	
tgc cgg aat ttt ctg ggg cat tgg tat gat tcc tat gtt aat gcc aca	4549
Cys Arg Asn Phe Leu Gly His Trp Tyr Asp Ser Tyr Val Asn Ala Thr	
1035	1040
1045	
acc att ttt gat gat tca gac aaa aca aag ggc tat gat ttc aat aaa	4597
Thr Ile Phe Asp Asp Ser Asp Lys Thr Lys Gly Tyr Asp Phe Asn Lys	
1050	1055
1060	
gga caa tgg cgc gac ttt gtc tta aaa gga cat aaa aat act aat cgt	4645
Gly Gln Trp Arg Asp Phe Val Leu Lys Gly His Lys Asn Thr Asn Arg	
1065	1070
1075	
cgc gtt gat tac agt tac gaa atc aat ccg gtg gga acc ccg cag gaa	4693
Arg Val Asp Tyr Ser Tyr Glu Ile Asn Pro Val Gly Thr Pro Gln Glu	
1080	1085
1090	1095
tgt att gat ata att caa aca gac att gac gcc aca gga ata tca aat	4741
Cys Ile Asp Ile Ile Gln Thr Asp Ile Asp Ala Thr Gly Ile Ser Asn	
1100	1105
1110	
att tgt tgt ggg ttt gaa gct aat gga aca gta gat gaa att atc tct	4789
Ile Cys Cys Gly Phe Glu Ala Asn Gly Thr Val Asp Glu Ile Ile Ser	
1115	1120
1125	
tcc atg aag ctc ttc cag tct gat gta atg ccg ttt ctt aaa gaa aaa	4837
Ser Met Lys Leu Phe Gln Ser Asp Val Met Pro Phe Leu Lys Glu Lys	
1130	1135
1140	
caa cgt tcg cta tta tat tag ctaaggaaaa tgaa atg aaa ttt ggc ttg	4887
Gln Arg Ser Leu Leu Tyr Met Lys Phe Gly Leu	
1145	1150
1155	
ttc ttc ctt aac ttt atc aat tca aca act att caa gag caa agt ata	4935
Phe Phe Leu Asn Phe Ile Asn Ser Thr Thr Ile Gln Glu Gln Ser Ile	
1160	1165
1170	
gct cgc atg cag gaa ata aca gaa tat gtc gac aaa ttg aat ttt gag	4983
Ala Arg Met Gln Glu Ile Thr Glu Tyr Val Asp Lys Leu Asn Phe Glu	

1175	1180	1185	
cag att ttg gtg tgt gaa aat cat ttt tca gat aat ggt gtt gtc ggc			5031
Gln Ile Leu Val Cys Glu Asn His Phe Ser Asp Asn Gly Val Val Gly			
1190	1195	1200	
gct cct ttg act gtt tct ggt ttt tta ctt ggc cta aca gaa aaa att			5079
Ala Pro Leu Thr Val Ser Gly Phe Leu Leu Gly Leu Thr Glu Lys Ile			
1205	1210	1215	
aaa att ggt tca ttg aat cat gtc att aca act cat cat cct gtc cgc			5127
Lys Ile Gly Ser Leu Asn His Val Ile Thr Thr His His Pro Val Arg			
1220	1225	1230	1235
ata gcg gaa gaa gcg tgc tta ttg gat cag tta agc gaa gga aga ttt			5175
Ile Ala Glu Glu Ala Cys Leu Leu Asp Gln Leu Ser Glu Gly Arg Phe			
1240	1245	1250	
att tta gga ttt agt gat tgc gag aga aag gat gaa atg cat ttt ttc			5223
Ile Leu Gly Phe Ser Asp Cys Glu Arg Lys Asp Glu Met His Phe Phe			
1255	1260	1265	
aat cgc cct gaa caa tac cag cag caa tta ttt gaa gaa tgc tat gac			5271
Asn Arg Pro Glu Gln Tyr Gln Gln Gln Leu Phe Glu Glu Cys Tyr Asp			
1270	1275	1280	
att att aac gat gct tta aca aca ggc tat tgt aat cca aat ggc gat			5319
Ile Ile Asn Asp Ala Leu Thr Thr Gly Tyr Cys Asn Pro Asn Gly Asp			
1285	1290	1295	
ttt tat aat ttc ccc aaa ata tcc gtg aat ccc cat gct tat acg caa			5367
Phe Tyr Asn Phe Pro Lys Ile Ser Val Asn Pro His Ala Tyr Thr Gln			
1300	1305	1310	1315
aac ggg cct cgg aaa tat gta aca gca aca agt tgt cat gtt gtt gag			5415
Asn Gly Pro Arg Lys Tyr Val Thr Ala Thr Ser Cys His Val Val Glu			
1320	1325	1330	
tgg gct gct aaa aaa ggc att cct cta atc ttt aag tgg gat gat tcc			5463
Trp Ala Ala Lys Lys Gly Ile Pro Leu Ile Phe Lys Trp Asp Asp Ser			
1335	1340	1345	
aat gaa gtt aaa cat gaa tat gcg aaa aga tat caa gcc ata gca ggt			5511
Asn Glu Val Lys His Glu Tyr Ala Lys Arg Tyr Gln Ala Ile Ala Gly			
1350	1355	1360	
gaa tat ggt gtt gac ctg gca gag ata gat cat cag tta atg ata ttg			5559
Glu Tyr Gly Val Asp Leu Ala Glu Ile Asp His Gln Leu Met Ile Leu			
1365	1370	1375	
gtt aac tat agt gaa gac agt gag aaa gct aaa gag gaa acg cgt gca			5607
Val Asn Tyr Ser Glu Asp Ser Glu Lys Ala Lys Glu Glu Thr Arg Ala			
1380	1385	1390	1395
ttt ata agt gat tat att ctt gca atg cac cct aat gaa aat ttc gaa			5655
Phe Ile Ser Asp Tyr Ile Leu Ala Met His Pro Asn Glu Asn Phe Glu			
1400	1405	1410	

aag aaa ctt gaa gaa ata atc aca gaa aac tcc gtc gga gat tat atg 5703
Lys Lys Leu Glu Glu Ile Ile Thr Glu Asn Ser Val Gly Asp Tyr Met
1415 1420 1425

gaa tgt aca act gcg gct aaa ttg gca atg gag aaa tgt ggt gca aaa 5751
Glu Cys Thr Thr Ala Ala Lys Leu Ala Met Glu Lys Cys Gly Ala Lys
1430 1435 1440

ggt ata tta ttg tcc ttt gaa tca atg agt gat ttt aca cat caa ata 5799
Gly Ile Leu Leu Ser Phe Glu Ser Met Ser Asp Phe Thr His Gln Ile
1445 1450 1455

aac gca att gat att gtc aat gat aat att aaa aag tat cac atg taa 5847
Asn Ala Ile Asp Ile Val Asn Asp Asn Ile Lys Lys Tyr His Met
1460 1465 1470 1475

tataccctat ggatttcaag gtgcatcgcg acggcaaggg agcgaatccc cgggagcata 5907

tacccaatag atttcaagtt gcagtgccgc ggcaagtga cgcaccccca ggagcataga 5967

taactatgtg actggggtaa gtgaacgcag ccaacaaagc agcagcttga aagatgaagg 6027

gtatagataa cgatgtgacc ggggtgctg aacgcagcca acaaagaggc aacttgaaag 6087

ataacgggta taaaagggta tagcagtcac tctgccatat cctttaatat tagctgccga 6147

ggtaaacag gt atg act tca tat gtt gat aaa caa gaa atc aca gca agt 6198
Met Thr Ser Tyr Val Asp Lys Gln Glu Ile Thr Ala Ser
1480 1485

tca gaa att gat gat ttg att ttt tcg agt gat cca tta gtc tgg tct 6246
Ser Glu Ile Asp Asp Leu Ile Phe Ser Ser Asp Pro Leu Val Trp Ser
1490 1495 1500

tac gac gaa cag gaa aag att aga aaa aaa ctt gtg ctt gat gcg ttt 6294
Tyr Asp Glu Gln Glu Lys Ile Arg Lys Lys Leu Val Leu Asp Ala Phe
1505 1510 1515 1520

cgt cat cac tat aaa cat tgt caa gaa tac cgt cac tac tgt cag gca 6342
Arg His His Tyr Lys His Cys Gln Glu Tyr Arg His Tyr Cys Gln Ala
1525 1530 1535

cat aaa gta gat gac aat att acg gaa att gat gat ata cct gta ttc 6390
His Lys Val Asp Asp Asn Ile Thr Glu Ile Asp Asp Ile Pro Val Phe
1540 1545 1550

cca aca tca gtg ttt aag ttt act cgc tta tta act tct aat gag aac 6438
Pro Thr Ser Val Phe Lys Phe Thr Arg Leu Leu Thr Ser Asn Glu Asn
1555 1560 1565

gaa att gaa agt tgg ttt acc agt agt ggc aca aat ggc tta aaa agt 6486
Glu Ile Glu Ser Trp Phe Thr Ser Ser Gly Thr Asn Gly Leu Lys Ser
1570 1575 1580

cag gta cca cgt gac aga cta agt att gag agg ctc tta ggc tct gta 6534
Gln Val Pro Arg Asp Arg Leu Ser Ile Glu Arg Leu Leu Gly Ser Val

1585	1590	1595	1600	
agt tat ggt atg aaa tat att ggt agt tgg ttc gat cat caa atg gaa				6582
Ser Tyr Gly Met Lys Tyr Ile Gly Ser Trp Phe Asp His Gln Met Glu				
	1605	1610	1615	
ttg gtc aac ctg gga cca gat aga ttt aat gct cat aat att tgg ttt				6630
Leu Val Asn Leu Gly Pro Asp Arg Phe Asn Ala His Asn Ile Trp Phe				
	1620	1625	1630	
aaa tat gtt atg agc ttg gta gag tta tta tat cct acg tca ttc acc				6678
Lys Tyr Val Met Ser Leu Val Glu Leu Leu Tyr Pro Thr Ser Phe Thr				
	1635	1640	1645	
gta aca gaa gaa cac ata gat ttc gtt cag aca tta aat agt ctt gag				6726
Val Thr Glu Glu His Ile Asp Phe Val Gln Thr Leu Asn Ser Leu Glu				
	1650	1655	1660	
cga ata aaa cat caa ggg aaa gat att tgt ctt att ggt tcg cca tac				6774
Arg Ile Lys His Gln Gly Lys Asp Ile Cys Leu Ile Gly Ser Pro Tyr				
	1665	1670	1675	1680
ttt att tat ttg ctc tgc cgt tat atg aaa gat aaa aat atc tca ttt				6822
Phe Ile Tyr Leu Leu Cys Arg Tyr Met Lys Asp Lys Asn Ile Ser Phe				
	1685	1690	1695	
tct gga gat aaa agt ctt tat att ata acg ggg gga ggc tgg aaa agt				6870
Ser Gly Asp Lys Ser Leu Tyr Ile Ile Thr Gly Gly Gly Trp Lys Ser				
	1700	1705	1710	
tac gaa aaa gaa tct ttg aag cgt aat gat ttc aat cat ctt tta ttc				6918
Tyr Glu Lys Glu Ser Leu Lys Arg Asn Asp Phe Asn His Leu Leu Phe				
	1715	1720	1725	
gac act ttc aac ctc agt aat att aac cag atc cgt gat ata ttt aat				6966
Asp Thr Phe Asn Leu Ser Asn Ile Asn Gln Ile Arg Asp Ile Phe Asn				
	1730	1735	1740	
caa gtt gaa ctc aac act tgt ttc ttt gag gat gaa atg caa cgt aaa				7014
Gln Val Glu Leu Asn Thr Cys Phe Phe Glu Asp Glu Met Gln Arg Lys				
	1745	1750	1755	1760
cat gtt ccg ccg tgg gta tat gcg cga gca ctt gat cct gaa aca ttg				7062
His Val Pro Pro Trp Val Tyr Ala Arg Ala Leu Asp Pro Glu Thr Leu				
	1765	1770	1775	
aaa ccg gta cct gat ggg atg cct ggt ttg atg agt tat atg gat gca				7110
Lys Pro Val Pro Asp Gly Met Pro Gly Leu Met Ser Tyr Met Asp Ala				
	1780	1785	1790	
tca tca acg agt tat ccg gca ttt att gtt acc gat gat atc gga ata				7158
Ser Ser Thr Ser Tyr Pro Ala Phe Ile Val Thr Asp Asp Ile Gly Ile				
	1795	1800	1805	
att agc aga gaa tat ggt caa tat cct ggt gta ttg gtt gaa att tta				7206
Ile Ser Arg Glu Tyr Gly Gln Tyr Pro Gly Val Leu Val Glu Ile Leu				
	1810	1815	1820	

cgt cgc gtt aat acg agg aaa caa aaa ggt tgt gct tta agc tta act 7254
 Arg Arg Val Asn Thr Arg Lys Gln Lys Gly Cys Ala Leu Ser Leu Thr
 1825 1830 1835 1840

gaa gca ttt ggt agt tga tagtttcttt ggaaagagga gcagtcaaag 7302
 Glu Ala Phe Gly Ser
 1845

gctcatttgt tcaatgcttt tgcgaaacgt tttgtcgaac tctaggcgaa ggttctcgac 7362

tttccccgca tcaggggtat atacaagtaa aaaagctcag ggggtaaacc tgagcttggg 7422

atggtgattt ttaagtatga gatacatggg cggatttaaa taacggagtc agtttggaaa 7482

tatcaacggt cttttctgct ttatcgaggc tataagtttc ttgcagtttt aaccacaacc 7542

gcgagagct gccaaagtact tgtgacagtt ttattgccat ctctggcgtg actgctgctt 7602

tacacgatac taaacggtga accgtagagg gagcaacatt caatgcccgc gctaagttca 7662

cgaattc 7669

<210> 2

<211> 480

<212> PRT

<213> Xenorhabdus luminescens

<400> 2

Met Asn Lys Lys Ile Ser Phe Ile Ile Asn Gly Arg Val Glu Ile Phe
 1 5 10 15

Pro Glu Ser Asp Asp Leu Val Gln Ser Ile Asn Phe Gly Asp Asn Ser
 20 25 30

Val His Leu Pro Val Leu Asn Asp Ser Gln Val Lys Asn Ile Ile Asp
 35 40 45

Tyr Asn Glu Asn Asn Glu Leu Gln Leu His Asn Ile Ile Asn Phe Leu
 50 55 60

Tyr Thr Val Gly Gln Arg Trp Lys Asn Glu Glu Tyr Ser Arg Arg Arg
 65 70 75 80

Thr Tyr Ile Arg Asp Leu Lys Arg Tyr Met Gly Tyr Ser Glu Glu Met
 85 90 95

Ala Lys Leu Glu Ala Asn Trp Ile Ser Met Ile Leu Cys Ser Lys Gly
 100 105 110

Gly Leu Tyr Asp Leu Val Lys Asn Glu Leu Gly Ser Arg His Ile Met
 115 120 125

Asp Glu Trp Leu Pro Gln Asp Glu Ser Tyr Ile Arg Ala Phe Pro Lys
 130 135 140

Gly Lys Ser Val His Leu Leu Thr Gly Asn Val Pro Leu Ser Gly Val
 145 150 155 160

Leu Ser Ile Leu Arg Ala Ile Leu Thr Lys Asn Gln Cys Ile Ile Lys
 165 170 175

Thr Ser Ser Thr Asp Pro Phe Thr Ala Asn Ala Leu Ala Leu Ser Phe
 180 185 190

Ile Asp Val Asp Pro His His Pro Val Thr Arg Ser Leu Ser Val Val
 195 200 205

Tyr Trp Gln His Gln Gly Asp Ile Ser Leu Ala Lys Glu Ile Met Gln
 210 215 220

His Ala Asp Val Val Val Ala Trp Gly Gly Glu Asp Ala Ile Asn Trp
 225 230 235 240

Ala Val Lys His Ala Pro Pro Asp Ile Asp Val Met Lys Phe Gly Pro
 245 250 255

Lys Lys Ser Phe Cys Ile Ile Asp Asn Pro Val Asp Leu Val Ser Ala
 260 265 270

Ala Thr Gly Ala Ala His Asp Val Cys Phe Tyr Asp Gln Gln Ala Cys
 275 280 285

Phe Ser Thr Gln Asn Ile Tyr Tyr Met Gly Ser His Tyr Glu Glu Phe
 290 295 300

Lys Leu Ala Leu Ile Glu Lys Leu Asn Leu Tyr Ala His Ile Leu Pro
 305 310 315 320

Asn Thr Lys Lys Asp Phe Asp Glu Lys Ala Ala Tyr Ser Leu Val Gln
 325 330 335

Lys Glu Cys Leu Phe Ala Gly Leu Lys Val Glu Val Asp Val His Gln
 340 345 350

Arg Trp Met Val Ile Glu Ser Asn Ala Gly Val Glu Leu Asn Gln Pro
 355 360 365

Leu Gly Arg Cys Val Tyr Leu His His Val Asp Asn Ile Glu Gln Ile
 370 375 380

Leu Pro Tyr Val Arg Lys Asn Lys Thr Gln Thr Ile Ser Val Phe Pro
 385 390 395 400

Trp Glu Ala Ala Leu Lys Tyr Arg Asp Leu Leu Ala Leu Lys Gly Ala
 405 410 415

Glu Arg Ile Val Glu Ala Gly Met Asn Asn Ile Phe Arg Val Gly Gly
 420 425 430

Ala His Asp Gly Met Arg Pro Leu Gln Arg Leu Val Thr Tyr Ile Ser
 435 440 445

His Glu Arg Pro Ser His Tyr Thr Ala Lys Asp Val Ala Val Glu Ile
 450 455 460

Glu Gln Thr Arg Phe Leu Glu Glu Asp Lys Phe Leu Val Phe Val Pro
 465 470 475 480

<210> 3
 <211> 307
 <212> PRT
 <213> Xenorhabdus luminescens

<400> 3
 Met Glu Asn Lys Ser Arg Tyr Lys Thr Ile Asp His Val Ile Cys
 1 5 10 15
 Val Glu Glu Asn Arg Lys Ile His Val Trp Glu Thr Leu Pro Lys Glu
 20 25 30
 Asn Ser Pro Lys Arg Lys Asn Thr Leu Ile Ile Ala Ser Gly Phe Ala
 35 40 45
 Arg Arg Met Asp His Phe Ala Gly Leu Ala Glu Tyr Leu Ser Gln Asn
 50 55 60
 Gly Phe His Val Ile Arg Tyr Asp Ser Leu His His Val Gly Leu Ser
 65 70 75
 Ser Gly Thr Ile Asp Glu Phe Thr Met Ser Ile Gly Lys Gln Ser Leu
 80 85 90 95
 Leu Ala Val Val Asp Trp Leu Asn Thr Arg Lys Ile Asn Asn Leu Gly
 100 105 110
 Met Leu Ala Ser Ser Leu Ser Ala Arg Ile Ala Tyr Ala Ser Leu Ser
 115 120 125
 Glu Ile Asn Val Ser Phe Leu Ile Thr Ala Val Gly Val Val Asn Leu
 130 135 140
 Arg Tyr Thr Leu Glu Arg Ala Leu Gly Phe Asp Tyr Leu Ser Leu Pro
 145 150 155
 Ile Asp Glu Leu Pro Asp Asn Leu Asp Phe Glu Gly His Lys Leu Gly
 160 165 170 175
 Ala Glu Val Phe Ala Arg Asp Cys Phe Asp Ser Gly Trp Glu Asp Leu
 180 185 190
 Thr Ser Thr Ile Asn Ser Met Met His Leu Asp Ile Pro Phe Ile Ala
 195 200 205
 Phe Thr Ala Asn Asn Asp Asp Trp Val Lys Gln Asp Glu Val Ile Thr
 210 215 220
 Leu Leu Ser Ser Ile Arg Ser His Gln Cys Lys Ile Tyr Ser Leu Leu
 225 230 235

Gly Ser Ser His Asp Leu Gly Glu Asn Leu Val Val Leu Arg Asn Phe
40 245 250 255

Tyr Gln Ser Val Thr Lys Ala Ala Ile Ala Met Asp Asn Gly Cys Leu
260 265 270

Asp Ile Asp Val Asp Ile Ile Glu Pro Ser Phe Glu His Leu Thr Ile
275 280 285

Ala Ala Val Asn Glu Arg Arg Met Lys Ile Glu Ile Glu Asn Gln Val
290 295 300

Ile Ser Leu Ser
305

<210> 4

<211> 360

<212> PRT

<213> Xenorhabdus luminescens

<400> 4

Met Lys Phe Gly Asn Phe Leu Leu Thr Tyr Gln Pro Pro Gln Phe Ser
1 5 10 15

Gln Thr Glu Val Met Lys Arg Leu Val Lys Leu Gly Arg Ile Ser Glu
20 25 30

Glu Cys Gly Phe Asp Thr Val Trp Leu Leu Glu His His Phe Thr Glu
35 40 45

Phe Gly Leu Leu Gly Asn Pro Tyr Val Ala Ala Ala Tyr Leu Leu Gly
50 55 60

Ala Thr Lys Lys Leu Asn Val Gly Thr Ala Ala Ile Val Leu Pro Thr
65 70 75 80

Ala His Pro Val Arg Gln Leu Glu Glu Val Asn Leu Leu Asp Gln Met
85 90 95

Ser Lys Gly Arg Phe Arg Phe Gly Ile Cys Arg Gly Leu Tyr Asn Lys
100 105 110

Asp Phe Arg Val Phe Gly Thr Asp Met Asn Asn Ser Arg Ala Leu Met
115 120 125

Glu Cys Trp Tyr Lys Leu Ile Arg Asn Gly Met Thr Glu Gly Tyr Met
130 135 140

Glu Ala Asp Asn Glu His Ile Lys Phe His Lys Val Lys Val Leu Pro
145 150 155 160

Thr Ala Tyr Ser Gln Gly Gly Ala Pro Ile Tyr Val Val Ala Glu Ser
165 170 175

Ala Ser Thr Thr Glu Trp Ala Ala Gln His Gly Leu Pro Met Ile Leu

	180	185	190
Ser Trp Ile Ile Asn Thr Asn Glu Lys Lys Ala Gln Ile Glu Leu Tyr	195	200	205
Asn Glu Val Ala Gln Glu Tyr Gly His Asp Ile His Asn Ile Asp His	210	215	220
Cys Leu Ser Tyr Ile Thr Ser Val Asp His Asp Ser Met Lys Ala Lys	225	230	235
Glu Ile Cys Arg Asn Phe Leu Gly His Trp Tyr Asp Ser Tyr Val Asn	245	250	255
Ala Thr Thr Ile Phe Asp Asp Ser Asp Lys Thr Lys Gly Tyr Asp Phe	260	265	270
Asn Lys Gly Gln Trp Arg Asp Phe Val Leu Lys Gly His Lys Asn Thr	275	280	285
Asn Arg Arg Val Asp Tyr Ser Tyr Glu Ile Asn Pro Val Gly Thr Pro	290	295	300
Gln Glu Cys Ile Asp Ile Ile Gln Thr Asp Ile Asp Ala Thr Gly Ile	305	310	315
Ser Asn Ile Cys Cys Gly Phe Glu Ala Asn Gly Thr Val Asp Glu Ile	325	330	335
Ile Ser Ser Met Lys Leu Phe Gln Ser Asp Val Met Pro Phe Leu Lys	340	345	350
Glu Lys Gln Arg Ser Leu Leu Tyr	355	360	

<210> 5
 <211> 324
 <212> PRT
 <213> Xenorhabdus luminescens

<400> 5
 Met Lys Phe Gly Leu Phe Phe Leu Asn Phe Ile Asn Ser Thr Thr
 1 5 10 15
 Ile Gln Glu Gln Ser Ile Ala Arg Met Gln Glu Ile Thr Glu Tyr Val
 20 25 30
 Asp Lys Leu Asn Phe Glu Gln Ile Leu Val Cys Glu Asn His Phe Ser
 35 40 45
 Asp Asn Gly Val Val Gly Ala Pro Leu Thr Val Ser Gly Phe Leu Leu
 50 55 60
 Gly Leu Thr Glu Lys Ile Lys Ile Gly Ser Leu Asn His Val Ile Thr
 65 70 75

Thr His His Pro Val Arg Ile Ala Glu Glu Ala Cys Leu Leu Asp Gln
 80 85 90 95
 Leu Ser Glu Gly Arg Phe Ile Leu Gly Phe Ser Asp Cys Glu Arg Lys
 100 105 110
 Asp Glu Met His Phe Phe Asn Arg Pro Glu Gln Tyr Gln Gln Gln Leu
 115 120 125
 Phe Glu Glu Cys Tyr Asp Ile Ile Asn Asp Ala Leu Thr Thr Gly Tyr
 130 135 140
 Cys Asn Pro Asn Gly Asp Phe Tyr Asn Phe Pro Lys Ile Ser Val Asn
 145 150 155
 Pro His Ala Tyr Thr Gln Asn Gly Pro Arg Lys Tyr Val Thr Ala Thr
 160 165 170 175
 Ser Cys His Val Val Glu Trp Ala Ala Lys Lys Gly Ile Pro Leu Ile
 180 185 190
 Phe Lys Trp Asp Asp Ser Asn Glu Val Lys His Glu Tyr Ala Lys Arg
 195 200 205
 Tyr Gln Ala Ile Ala Gly Glu Tyr Gly Val Asp Leu Ala Glu Ile Asp
 210 215 220
 His Gln Leu Met Ile Leu Val Asn Tyr Ser Glu Asp Ser Glu Lys Ala
 225 230 235
 Lys Glu Glu Thr Arg Ala Phe Ile Ser Asp Tyr Ile Leu Ala Met His
 240 245 250 255
 Pro Asn Glu Asn Phe Glu Lys Lys Leu Glu Glu Ile Ile Thr Glu Asn
 260 265 270
 Ser Val Gly Asp Tyr Met Glu Cys Thr Thr Ala Ala Lys Leu Ala Met
 275 280 285
 Glu Lys Cys Gly Ala Lys Gly Ile Leu Leu Ser Phe Glu Ser Met Ser
 290 295 300
 Asp Phe Thr His Gln Ile Asn Ala Ile Asp Ile Val Asn Asp Asn Ile
 305 310 315
 Lys Lys Tyr His Met
 320

<210> 6

<211> 370

<212> PRT

<213> Xenorhabdus luminescens

<400> 6

Met Thr Ser Tyr Val Asp Lys Gln Glu Ile Thr Ala Ser Ser Glu Ile
 1 5 10 15

Asp Asp Leu Ile Phe Ser Ser Asp Pro Leu Val Trp Ser Tyr Asp Glu
 20 25 30
 Gln Glu Lys Ile Arg Lys Lys Leu Val Leu Asp Ala Phe Arg His His
 35 40 45
 Tyr Lys His Cys Gln Glu Tyr Arg His Tyr Cys Gln Ala His Lys Val
 50 55 60
 Asp Asp Asn Ile Thr Glu Ile Asp Asp Ile Pro Val Phe Pro Thr Ser
 65 70 75 80
 Val Phe Lys Phe Thr Arg Leu Leu Thr Ser Asn Glu Asn Glu Ile Glu
 85 90 95
 Ser Trp Phe Thr Ser Ser Gly Thr Asn Gly Leu Lys Ser Gln Val Pro
 100 105 110
 Arg Asp Arg Leu Ser Ile Glu Arg Leu Leu Gly Ser Val Ser Tyr Gly
 115 120 125
 Met Lys Tyr Ile Gly Ser Trp Phe Asp His Gln Met Glu Leu Val Asn
 130 135 140
 Leu Gly Pro Asp Arg Phe Asn Ala His Asn Ile Trp Phe Lys Tyr Val
 145 150 155 160
 Met Ser Leu Val Glu Leu Leu Tyr Pro Thr Ser Phe Thr Val Thr Glu
 165 170 175
 Glu His Ile Asp Phe Val Gln Thr Leu Asn Ser Leu Glu Arg Ile Lys
 180 185 190
 His Gln Gly Lys Asp Ile Cys Leu Ile Gly Ser Pro Tyr Phe Ile Tyr
 195 200 205
 Leu Leu Cys Arg Tyr Met Lys Asp Lys Asn Ile Ser Phe Ser Gly Asp
 210 215 220
 Lys Ser Leu Tyr Ile Ile Thr Gly Gly Gly Trp Lys Ser Tyr Glu Lys
 225 230 235 240
 Glu Ser Leu Lys Arg Asn Asp Phe Asn His Leu Leu Phe Asp Thr Phe
 245 250 255
 Asn Leu Ser Asn Ile Asn Gln Ile Arg Asp Ile Phe Asn Gln Val Glu
 260 265 270
 Leu Asn Thr Cys Phe Phe Glu Asp Glu Met Gln Arg Lys His Val Pro
 275 280 285
 Pro Trp Val Tyr Ala Arg Ala Leu Asp Pro Glu Thr Leu Lys Pro Val
 290 295 300
 Pro Asp Gly Met Pro Gly Leu Met Ser Tyr Met Asp Ala Ser Ser Thr
 305 310 315 320

Ser Tyr Pro Ala Phe Ile Val Thr Asp Asp Ile Gly Ile Ile Ser Arg
325 330 335

Glu Tyr Gly Gln Tyr Pro Gly Val Leu Val Glu Ile Leu Arg Arg Val
340 345 350

Asn Thr Arg Lys Gln Lys Gly Cys Ala Leu Ser Leu Thr Glu Ala Phe
355 360 365

Gly Ser
370

<210> 7

<211> 21

<212> DNA

<213> Synthetic

<400>

tacctagggg gaaagagaat g

21

INTERNATIONAL SEARCH REPORT

national Application No PCT/US 99/28733

A. CLASSIFICATION OF SUBJECT MATTER
IPC 7 G01N27/327 C12Q1/00 A61M5/142

According to International Patent Classification (IPC) or to both national classification and IPC

B. FIELDS SEARCHED

Minimum documentation searched (classification system followed by classification symbols)
IPC 7 C12Q G01N A61M

Documentation searched other than minimum documentation to the extent that such documents are included in the fields searched

Electronic data base consulted during the international search (name of data base and, where practical, search terms used)

C. DOCUMENTS CONSIDERED TO BE RELEVANT

Category °	Citation of document, with indication, where appropriate, of the relevant passages	Relevant to claim No.
A	US 5 756 351 A (ISACOFF EHUD Y ET AL) 26 May 1998 (1998-05-26) the whole document ---	1
A	WO 98 22820 A (MINIMED INC ;LAWRENCE LIVERMORE NATIONAL LA (US)) 28 May 1998 (1998-05-28) the whole document ---	1
A	US 5 109 850 A (BLANCO ERNESTO E ET AL) 5 May 1992 (1992-05-05) abstract ---	1
A	US 5 294 541 A (KAPLAN DAVID S ET AL) 15 March 1994 (1994-03-15) abstract ---	1
	-/--	

Further documents are listed in the continuation of box C. Patent family members are listed in annex.

° Special categories of cited documents :

<p>*A* document defining the general state of the art which is not considered to be of particular relevance</p> <p>*E* earlier document but published on or after the international filing date</p> <p>*L* document which may throw doubts on priority claim(s) or which is cited to establish the publication date of another citation or other special reason (as specified)</p> <p>*O* document referring to an oral disclosure, use, exhibition or other means</p> <p>*P* document published prior to the international filing date but later than the priority date claimed</p>	<p>*T* later document published after the international filing date or priority date and not in conflict with the application but cited to understand the principle or theory underlying the invention</p> <p>*X* document of particular relevance; the claimed invention cannot be considered novel or cannot be considered to involve an inventive step when the document is taken alone</p> <p>*Y* document of particular relevance; the claimed invention cannot be considered to involve an inventive step when the document is combined with one or more other such documents, such combination being obvious to a person skilled in the art.</p> <p>*&* document member of the same patent family</p>
--	--

Date of the actual completion of the international search 7 April 2000	Date of mailing of the international search report 20/04/2000
--	---

Name and mailing address of the ISA European Patent Office, P.B. 5818 Patentlaan 2 NL - 2280 HV Rijswijk Tel. (+31-70) 340-2040, Tx. 31 651 epo nl, Fax: (+31-70) 340-3016	Authorized officer Moreno, C
--	--

INTERNATIONAL SEARCH REPORT

International Application No
PCT/US 99/28733

C.(Continuation) DOCUMENTS CONSIDERED TO BE RELEVANT		
Category °	Citation of document, with indication, where appropriate, of the relevant passages	Relevant to claim No.
A	WO 90 05910 A (I STAT CORP) 31 May 1990 (1990-05-31) examples -----	1

INTERNATIONAL SEARCH REPORT

Information on patent family members

national Application No

PCT/US 99/28733

Patent document cited in search report	Publication date	Patent family member(s)	Publication date
US 5756351 A	26-05-1998	NONE	
WO 9822820 A	28-05-1998	US 6002954 A AU 5446098 A	14-12-1999 10-06-1998
US 5109850 A	05-05-1992	NONE	
US 5294541 A	15-03-1994	NONE	
WO 9005910 A	31-05-1990	CA 2002848 A CA 2221178 A EP 0442969 A JP 4503249 T KR 175917 B SG 45431 A US 5554339 A US 5200051 A US 5837446 A US 5837454 A US 5063081 A US 5212050 A US 5466575 A	14-05-1990 14-05-1990 28-08-1991 11-06-1992 15-05-1999 16-01-1998 10-09-1996 06-04-1993 17-11-1998 17-11-1998 05-11-1991 18-05-1993 14-11-1995