

INTERNATIONAL APPLICATION PUBLISHED UNDER THE PATENT COOPERATION TREATY (PCT)

<p>(51) International Patent Classification ⁵ : G08B 5/30, G09F 9/37</p>	A1	<p>(11) International Publication Number: WO 93/18491 (43) International Publication Date: 16 September 1993 (16.09.93)</p>
<p>(21) International Application Number: PCT/IT93/00021 (22) International Filing Date: 9 March 1993 (09.03.93) (30) Priority data: TO92A000193 9 March 1992 (09.03.92) IT (71)(72) Applicants and Inventors: BUCCHINI, Luciano [IT/IT]; Via Rubino, 80, I-10137 Torino (IT). ERRIGO, Rita [IT/IT]; Corso Telesio, 11, I-10146 Torino (IT). (74) Agents: PRATO, Roberto et al.; Studio Torta Società Semplice, Via Viotti, 9, I-10121 Torino (IT). (81) Designated States: AT, AU, BB, BG, BR, CA, CH, CZ, DE, DK, ES, FI, GB, HU, JP, KP, KR, LK, LU, MG, MN, MW, NL, NO, NZ, PL, PT, RO, RU, SD, SE, SK, UA, US, European patent (AT, BE, CH, DE, DK, ES, FR, GB, GR, IE, IT, LU, MC, NL, PT, SE), OAPI patent (BF, BJ, CF, CG, CI, CM, GA, GN, ML, MR, SN, TD, TG).</p>		<p>Published <i>With international search report. Before the expiration of the time limit for amending the claims and to be republished in the event of the receipt of amendments.</i></p>

(54) Title: INDICATOR DEVICE

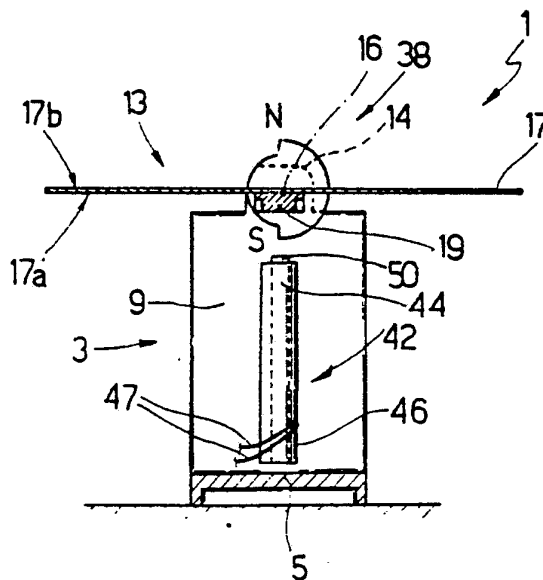

(57) Abstract

An electromagnetic indicator device comprising a U-shaped stator (3) supporting a rotor (13) in the form of a disk (17) rotating about an axis (16) between a first display position and an idle position. The rotor (13) is rotated by the attraction or repelling action of an electromagnet (42) on a cylindrical permanent magnet (38) fitted to the rotor (13) and magnetized linearly. The permanent magnet (38) presents asymmetrical reluctance (R) in relation to the magnetic axis (M), and defines spatially asymmetrical flux lines, so that the barycenter of the forces of attraction is shifted in the direction of least reluctance (R), thus generating a torque when the permanent magnet (38) is aligned with the core (44) of the electromagnet (42).

FOR THE PURPOSES OF INFORMATION ONLY

Codes used to identify States party to the PCT on the front pages of pamphlets publishing international applications under the PCT.

AT	Austria	FR	France	MR	Mauritania
AU	Australia	GA	Gabon	MW	Malawi
BB	Barbados	GB	United Kingdom	NL	Netherlands
BE	Belgium	GN	Guinea	NO	Norway
BF	Burkina Faso	GR	Greece	NZ	New Zealand
BG	Bulgaria	HU	Hungary	PL	Poland
BJ	Benin	IE	Ireland	PT	Portugal
BR	Brazil	IT	Italy	RO	Romania
CA	Canada	JP	Japan	RU	Russian Federation
CF	Central African Republic	KP	Democratic People's Republic of Korea	SD	Sudan
CG	Congo	KR	Republic of Korea	SE	Sweden
CH	Switzerland	KZ	Kazakhstan	SK	Slovak Republic
CI	Côte d'Ivoire	LJ	Liechtenstein	SN	Senegal
CM	Cameroon	LK	Sri Lanka	SU	Soviet Union
CS	Czechoslovakia	LU	Luxembourg	TD	Chad
CZ	Czech Republic	MC	Monaco	TG	Togo
DE	Germany	MG	Madagascar	UA	Ukraine
DK	Denmark	ML	Mali	US	United States of America
ES	Spain	MN	Mongolia	VN	Viet Nam
FI	Finland				

INDICATOR DEVICE

TECHNICAL FIELD

The present invention relates to an
5 electromagnetic indicator device.

BACKGROUND ART

Electromagnetic indicator devices are known
comprising a U-shaped stator supporting a disk rotor
rotated about an axis between a first display position
10 and an idle position separated angularly by 180°.

The disk is rotated by the attraction or repelling
action of an electromagnet on a cylindrical permanent
magnet fitted to the rotor and magnetized linearly. One
drawback of such devices is that, when the disk is set
15 to the display or idle position, the axis of the magnet
and the core of the electromagnet are aligned with no
torque between the two, so that the rotor reacts to any
mechanical stress on the stator by oscillating or
bouncing and so impairing the display characteristics of
20 the indicator device.

Various solutions have been proposed for
overcoming the above drawback. For example, USA Patent

4.393.362 of Staver Company Inc. (corresponding to Italian Patent 1.148.661) relates to an indicator device of the aforementioned type featuring a permanent magnet with North and South poles separated by an angle of
5 other than 180°. Stop elements are provided between the rotor and the stator so that, when the disk is set to the display or idle position, the North and South poles are not aligned with the electromagnet, and are drawn towards the electromagnet core.

10 Such devices, however, are extremely expensive, due to the complex techniques involved for producing the permanent magnet.

DISCLOSURE OF INVENTION

It is an object of the present invention to
15 provide a straightforward, low-cost device designed to overcome the above drawback typically associated with known devices.

According to the present invention, there is provided an indicator device comprising:

- 20 a stator;
- an indicator element fitted to said stator and rotating about a rotation axis;
- an electromagnet having an elongated permanent magnet core perpendicular to said axis of rotation;
- 25 a permanent magnet fitted to said indicator element and having two poles (North, South) which are attracted or repelled by said core according to the magnetization of the same;

characterized by the fact that the reluctance (R) of said permanent magnet is asymmetrical in relation to the magnetic axis (M), so as to define spatially asymmetrical flux lines in relation to said magnetic axis (M), and so that the barycenter of the forces of attraction generated between said magnet and said core is shifted towards the zone of least reluctance (R).

BRIEF DESCRIPTION OF DRAWINGS

A preferred, non-limiting embodiment of the present invention will be described by way of example with reference to the accompanying drawings, in which:

Fig.1 shows a side view of an indicator device in accordance with the teachings of the present invention;

Fig.2 shows a top plan view of the Fig.1 device;

Fig.3 shows a section of the Fig.1 device along line III-III in Fig.1;

Fig.4 shows a larger-scale view in perspective of a detail of the Fig.1 device.

BEST MODE FOR CARRYING OUT THE INVENTION

Number 1 in Figs 1 to 3 indicates an indicator device comprising a U-shaped stator 3 having a horizontal, substantially rectangular bottom wall 5 from the shorter sides of which extend upwards two flat rectangular supports 9, 10 perpendicular to wall 5.

Device 1 also comprises a rotor 13 hinged to the respective top ends 14, 15 of supports 9, 10, and rotating about an axis 16 parallel to bottom wall 5.

- 4 -

More specifically, rotor 13 comprises a flat circular disk 17 symmetrical in relation to axis 16 and integral with a diametrical T rib 19 extending along disk 17 and which terminates, beyond the edge of disk 17, in two opposite rectangular portions 21, 22 fitted on the ends with respective pins 24, 25 housed inside respective holes formed in respective ends 14, 15 of supports 9, 10.

Disk 17 presents opposite faces 17a, 17b of different colours, e.g. black and yellow.

Device 1 also presents a stop device 29 for limiting rotation of rotor 13 about axis 16 and between two predetermined angular positions.

Stop device 29 comprises a straight tab 30 located on one side of axis 16 and extending towards support 10 from a rectangular flange 31 integral with portion 22 and parallel to support 10. Tab 30 is designed to contact one of two shoulders 33, 34 formed by top end 15 on either side of axis 16. Shoulders 33, 34 are located at the same height in relation to bottom wall 5, and provide for limiting rotation of the rotor to 180° and between a first display position (Fig.2) wherein tab 30 contacts shoulder 33, and face 17b of disk 17 is outwards, and a second position (not shown) wherein tab 30 contacts shoulder 34, and disk 17, rotated 180° in relation to the display position, presents face 17a outwards.

Rotor 13 comprises a substantially cylindrical, isotropic permanent magnet 38 fitted to portion 21, coaxial with axis 16, and extruded from synthetic resin and ferromagnetic powder.

5 Stator 3 is fitted with a cylindrical electromagnet 42 adjacent to support 9 and extending from bottom wall 5 towards rotor 13. Electromagnet 42 consists of an elongated cylindrical permanent magnet core 44 wound with an insulated wire coil 46 energized
10 by d.c. voltage applied to terminals 47. Cylindrical core 44 is positioned perpendicular to axis 16 with its top end 50 facing magnet 38. When d.c. voltage is applied to terminals 47, core 44 is magnetized so as to form a North or South pole at end 50. Polarity inversion
15 of the voltage at terminals 47, by inverting the current flow direction in coil 46, provides for inverting the magnetic polarity of core 44.

With reference to Fig.s 3 and 4, permanent magnet 38 comprises two integral concentric half disks 38a, 38b
20 having different radii (r_1 , R_2) and arranged side by side along diametrical line (D) in Fig.4.

Magnet 38 is magnetized linearly, and presents diametrically opposed North and South poles along a magnetic axis (M) (shown by the arrow in Fig.4) lying on
25 diametrical line (D).

By virtue of presenting an asymmetrical structure in relation to magnetic axis (M) (and diametrical line (D)), magnet 38 generates asymmetrical flux lines (not

- 6 -

shown) in relation to magnetic axis (M), so that the magnetic reluctance (R) of magnet 38 is asymmetrical in relation to diametrical line (D) and magnetic axis (M).

As such, the barycenter of the forces of attraction generated between magnet 38 and core 44 of electromagnet 42 is shifted towards the zone of least reluctance (R), so that a magnetic torque is generated when the magnetic axis (M) of magnet 38 is aligned with core 44 of electromagnet 42 (Fig.3), i.e. when magnet 38 is set to the display or idle position. In the display or idle position, therefore, the magnetic torque so generated pushes tab 30 on to shoulder 33 or 34, thus preventing rotor 3 from oscillating, due to the "lateral recall" action produced by the magnetic torque.

Indicator device 1 is used as a basic unit on display boards (not shown) comprising a number of such devices arranged in rows and columns over a flat surface, with disk 17 facing outwards of the board, so as to form a matrix by which to display alphanumeric characters.

The indicator device according to the present invention therefore provides for overcoming the drawbacks typical of known devices.

Rotor 3 in fact is stabilized in an extremely straightforward manner, with no need for special, complex, high-cost permanent magnets.

To those skilled in the art it will be clear that changes may be made to the device as described and

illustrated herein without, however, departing from the scope of the present invention.

For example, changes may be made to the shape of permanent magnet 38, which may present, for example, a
5 cross section in the form of an irregular polygon, or edges of any shape, e.g. notched. Permanent magnet 38 may also present one or more internal cavities; may incorporate nonferrous, e.g. plastic, elements; and may present a nonisotropic internal structure with higher
10 density ferrous powder and synthetic resin portions.

Shoulders 33 and 34 may be located at different heights in relation to bottom wall 5, so as to determine and limit rotation of rotor 13 as required.

CLAIMS

1) An indicator device comprising:

a stator (3);

5 an indicator element (13) fitted to said stator (3) and rotating about a rotation axis (16);

an electromagnet (42) having an elongated permanent magnet core (44) perpendicular to said axis of rotation (16);

10 a permanent magnet (38) fitted to said indicator element (13) and having two poles (North, South) which are attracted or repelled by said core (44) according to the magnetization of the same;

characterized by the fact that the reluctance (R)
15 of said permanent magnet (38) is asymmetrical in relation to the magnetic axis (M), so as to define spatially asymmetrical flux lines in relation to said magnetic axis (M), and so that the barycenter of the forces of attraction generated between said magnet (38)
20 and said core (44) is shifted towards the zone of least reluctance (R).

2) A device as claimed in Claim 1, characterized by the fact that it comprises stop means (33, 34) on said stator (3), designed to cooperate with locating
25 means (30) on said indicator element (13); said stop means (33, 34) defining at least one limit position wherein said poles (North, South) of said permanent magnet (38) are aligned with said core (44), and said

locating means (30) are pushed on to said stop means (33, 34).

3) A device as claimed in Claim 1 or 2, characterized by the fact that the profile of said permanent magnet (38) is asymmetrical in relation to said magnetic axis (M).

4) A device as claimed in any one of the foregoing Claims, characterized by the fact that said permanent magnet (38) presents a section perpendicular to said axis of rotation (16) which is asymmetrical in relation to said magnetic axis (M).

5) A device as claimed in any one of the foregoing Claims, characterized by the fact that said permanent magnet (38) is substantially disk-shaped.

6) A device as claimed in Claim 5, characterized by the fact that said permanent magnet (38) comprises two integral concentric circular sectors (38a, 38b) having different radii (r_1 , R_2).

7) A device as claimed in Claim 5 or 6, characterized by the fact that said permanent magnet (38) comprises two half disks (38a, 38b) connected along a diametrical line (D) on which said magnetic axis (M) lies.

8) A device as claimed in any one of the foregoing Claims, characterized by the fact that said indicator element comprises a flat disk (17) having opposite faces (17a, 17b) of different colours.

9) A device as claimed in any one of the foregoing Claims, characterized by the fact that said permanent magnet (38) is made of ferromagnetic powder and synthetic resin.

5 10) A device as claimed in any one of the foregoing Claims from 2 to 9, characterized by the fact that said stop means comprise shoulders (33, 34) on said stator (3); said locating means comprising a tab (30) on said indicator element (13).

10 11) A display board, characterized by the fact that it comprises a number of indicator devices (1) as claimed in any one of the foregoing Claims from 1 to 10.

15 12) An indicator device and display board, substantially as described and illustrated herein with reference to the accompanying drawings.

1/2

FIG. 1

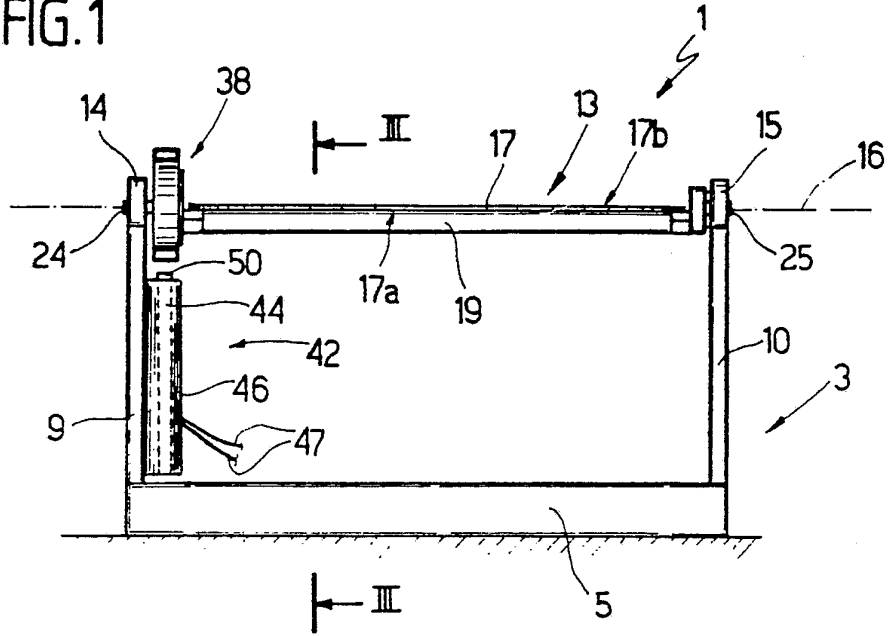
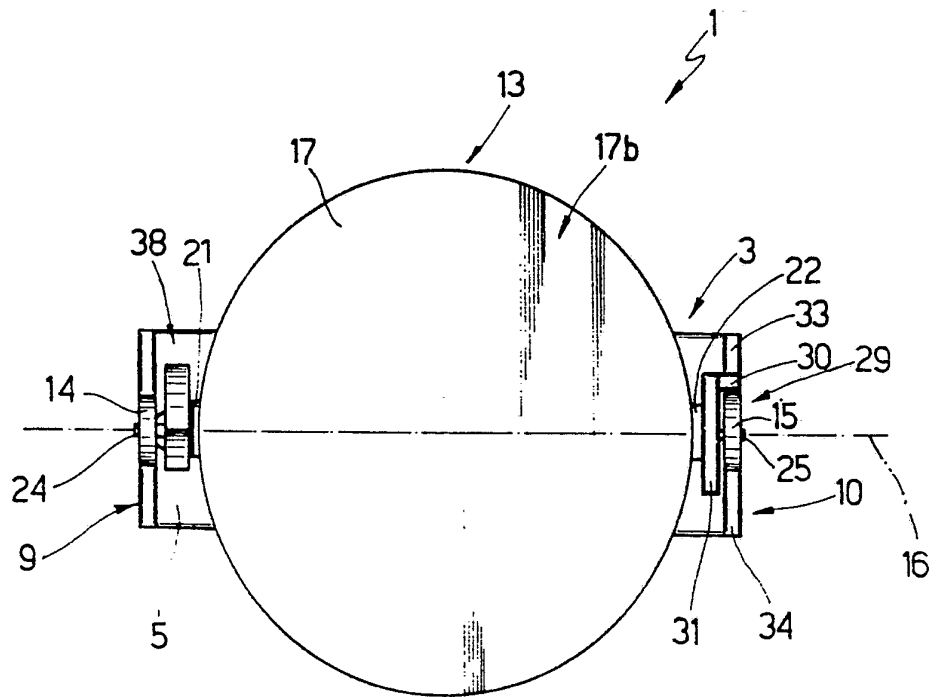

FIG. 2



2/2

FIG. 3

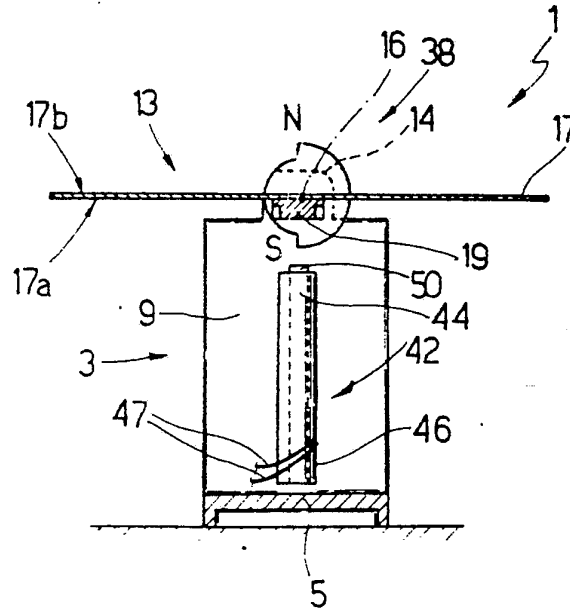
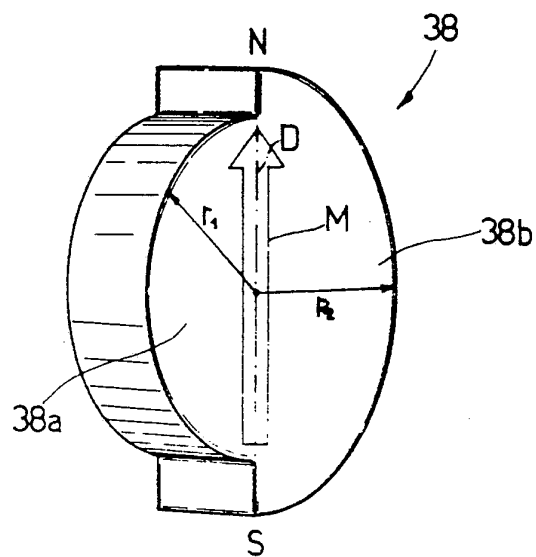

FIG. 4



INTERNATIONAL SEARCH REPORT

International Application No

PCT/IT 93/00021

I. CLASSIFICATION OF SUBJECT MATTER (if several classification symbols apply, indicate all) ⁶		
According to International Patent Classification (IPC) or to both National Classification and IPC Int.Cl. 5 G08B5/30; G09F9/37		
II. FIELDS SEARCHED		
Minimum Documentation Searched ⁷		
Classification System	Classification Symbols	
Int.Cl. 5	G08B ; G09F	
Documentation Searched other than Minimum Documentation to the Extent that such Documents are Included in the Fields Searched ⁸		
III. DOCUMENTS CONSIDERED TO BE RELEVANT⁹		
Category ^o	Citation of Document, ¹¹ with indication, where appropriate, of the relevant passages ¹²	Relevant to Claim No. ¹³
A	US,A,4 393 362 (A. SKROBISCH) 12 July 1983 cited in the application see column 1, line 18 - column 2, line 40; figure 5	1-2
A	FR,A,1 492 312 (DWTY ELECTRICS) 10 July 1967 see page 2, line 96 - page 3, line 45; figures 5-8	1
A	US,A,3 634 857 (G. PIHL) 11 January 1972 see abstract	1
<p>^o Special categories of cited documents :¹⁰</p> <p>"A" document defining the general state of the art which is not considered to be of particular relevance</p> <p>"E" earlier document but published on or after the international filing date</p> <p>"L" document which may throw doubts on priority claim(s) or which is cited to establish the publication date of another citation or other special reason (as specified)</p> <p>"O" document referring to an oral disclosure, use, exhibition or other means</p> <p>"P" document published prior to the international filing date but later than the priority date claimed</p> <p>"T" later document published after the international filing date or priority date and not in conflict with the application but cited to understand the principle or theory underlying the invention</p> <p>"X" document of particular relevance; the claimed invention cannot be considered novel or cannot be considered to involve an inventive step</p> <p>"Y" document of particular relevance; the claimed invention cannot be considered to involve an inventive step when the document is combined with one or more other such documents, such combination being obvious to a person skilled in the art.</p> <p>"&" document member of the same patent family</p>		
IV. CERTIFICATION		
Date of the Actual Completion of the International Search	Date of Mailing of this International Search Report	
05 JULY 1993	12. 07 93	
International Searching Authority	Signature of Authorized Officer	
EUROPEAN PATENT OFFICE	SGURA S.	

**ANNEX TO THE INTERNATIONAL SEARCH REPORT
ON INTERNATIONAL PATENT APPLICATION NO.**

IT 9300021
SA 72204

This annex lists the patent family members relating to the patent documents cited in the above-mentioned international search report. The members are as contained in the European Patent Office EDP file on The European Patent Office is in no way liable for these particulars which are merely given for the purpose of information.

05/07/93

Patent document cited in search report	Publication date	Patent family member(s)	Publication date
US-A-4393362	12-07-83	CA-A- 1187923	28-05-85
		DE-A, C 3229907	21-07-83
		FR-A, B 2520140	22-07-83
		GB-A, B 2113884	10-08-83
		JP-A- 58123578	22-07-83
		SE-B- 456955	14-11-88
		SE-A- 8206803	19-07-83
FR-A-1492312		None	
US-A-3634857	11-01-72	None	

EPO FORM P0479

For more details about this annex : see Official Journal of the European Patent Office, No. 12/82