

E. MASUREL.  
APPARATUS FOR DYEING.

No. 523,047.

Patented July 17, 1894.

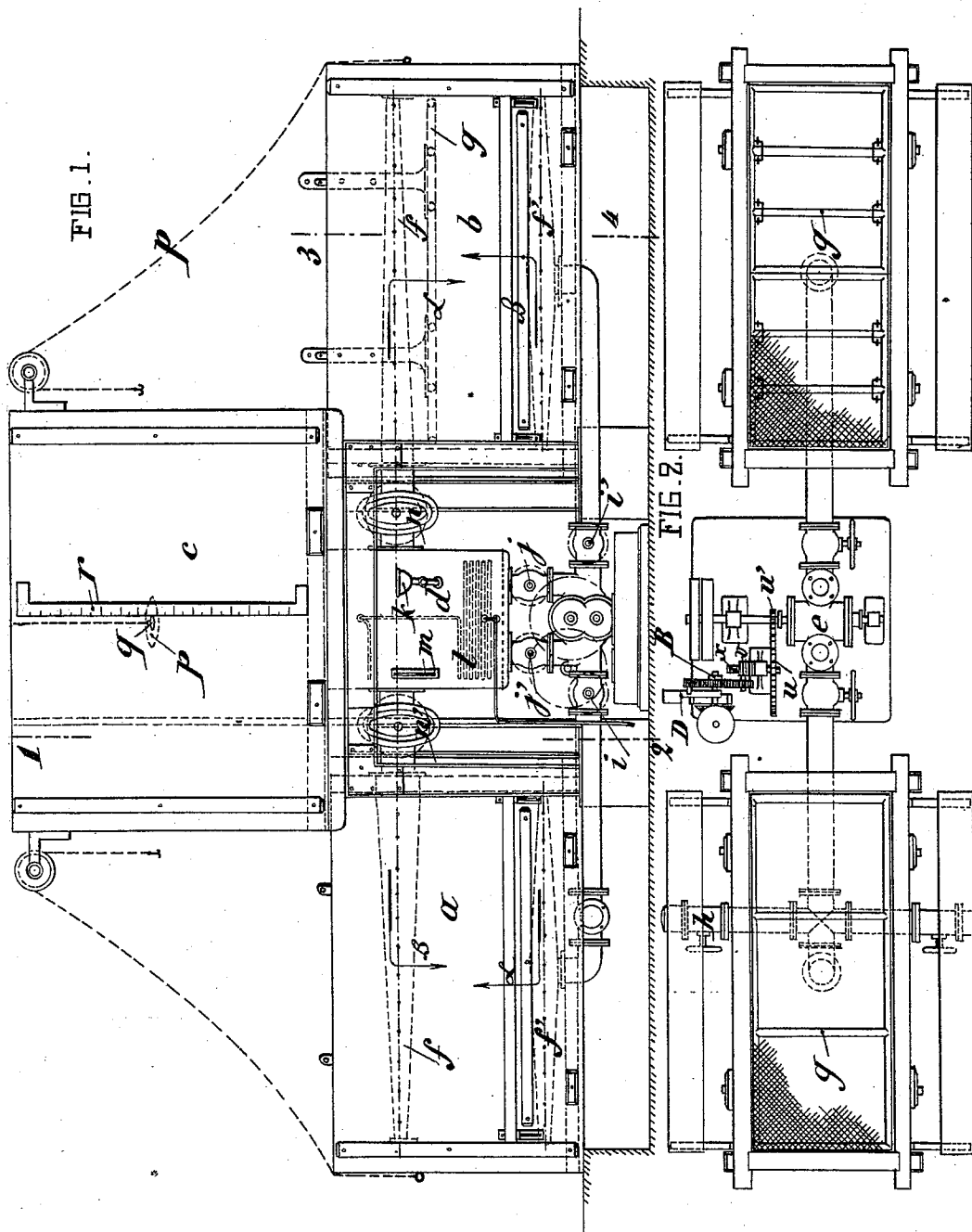

Witnesses  
L. M. Heckschlagar,  
E. S. Sherman

Inventor  
Edmond Masurel,  
By Brien & Knauth,  
his Attorneys.

(No Model.)

5 Sheets—Sheet 2.

E. MASUREL.  
APPARATUS FOR DYEING.

No. 523,047.

Patented July 17, 1894.

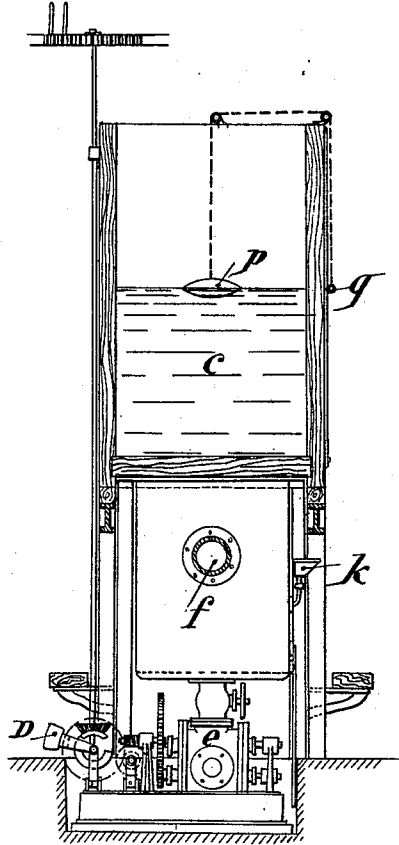
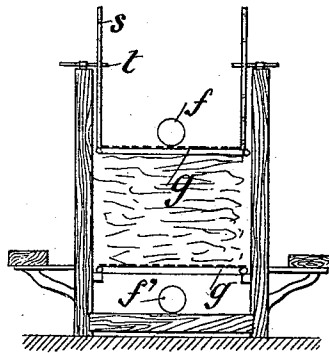

FIG. 3.



Witnesses:  
L. M. Hachschlager,  
E. L. Sherman

Inventor  
Edmond Masurel  
By Briesen Knauth  
his Attorneys.

E. MASUREL.  
APPARATUS FOR DYEING.

No. 523,047.

Patented July 17, 1894.

FIG. 4.

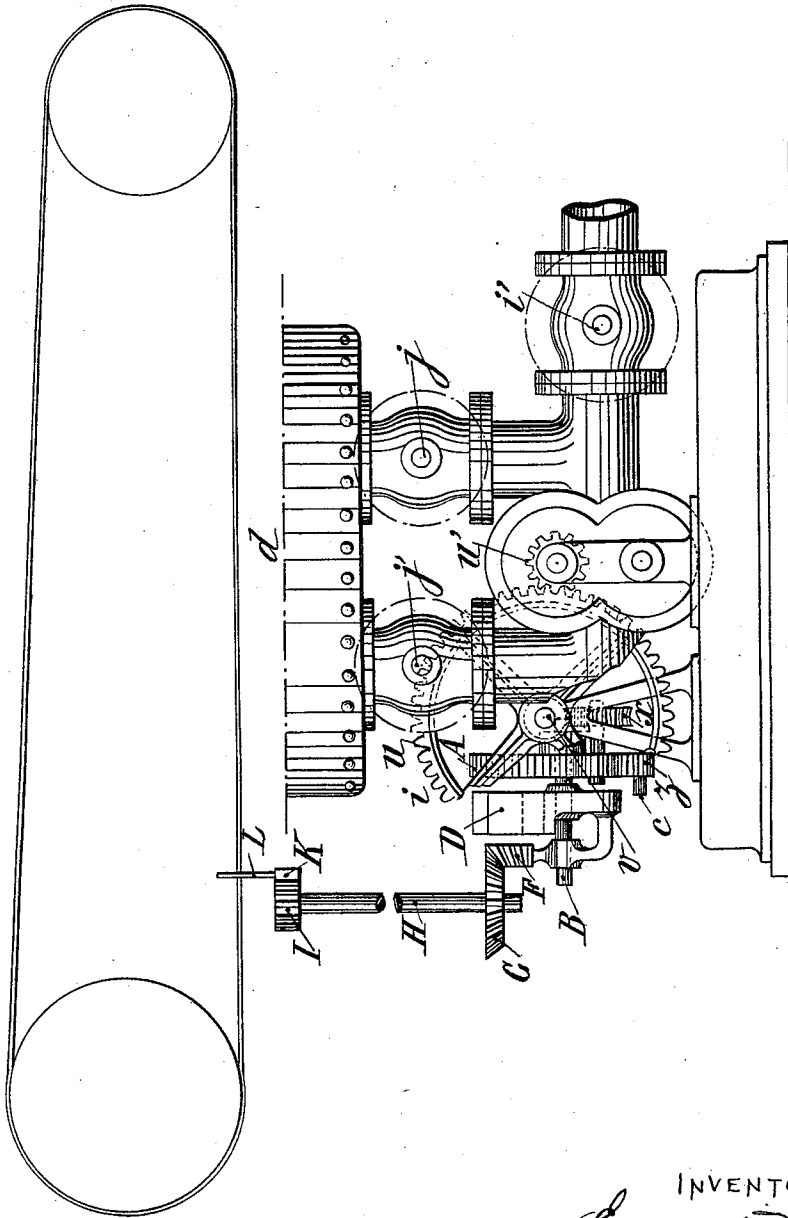

WITNESSES.

*Charles E. Smith*  
*Otto Schrenk*

INVENTOR

*Edmond Masurel,*  
BY *Briese & Knauth*

ATTORNEYS.

E. MASUREL.  
APPARATUS FOR DYEING.

No. 523,047.

Patented July 17, 1894.

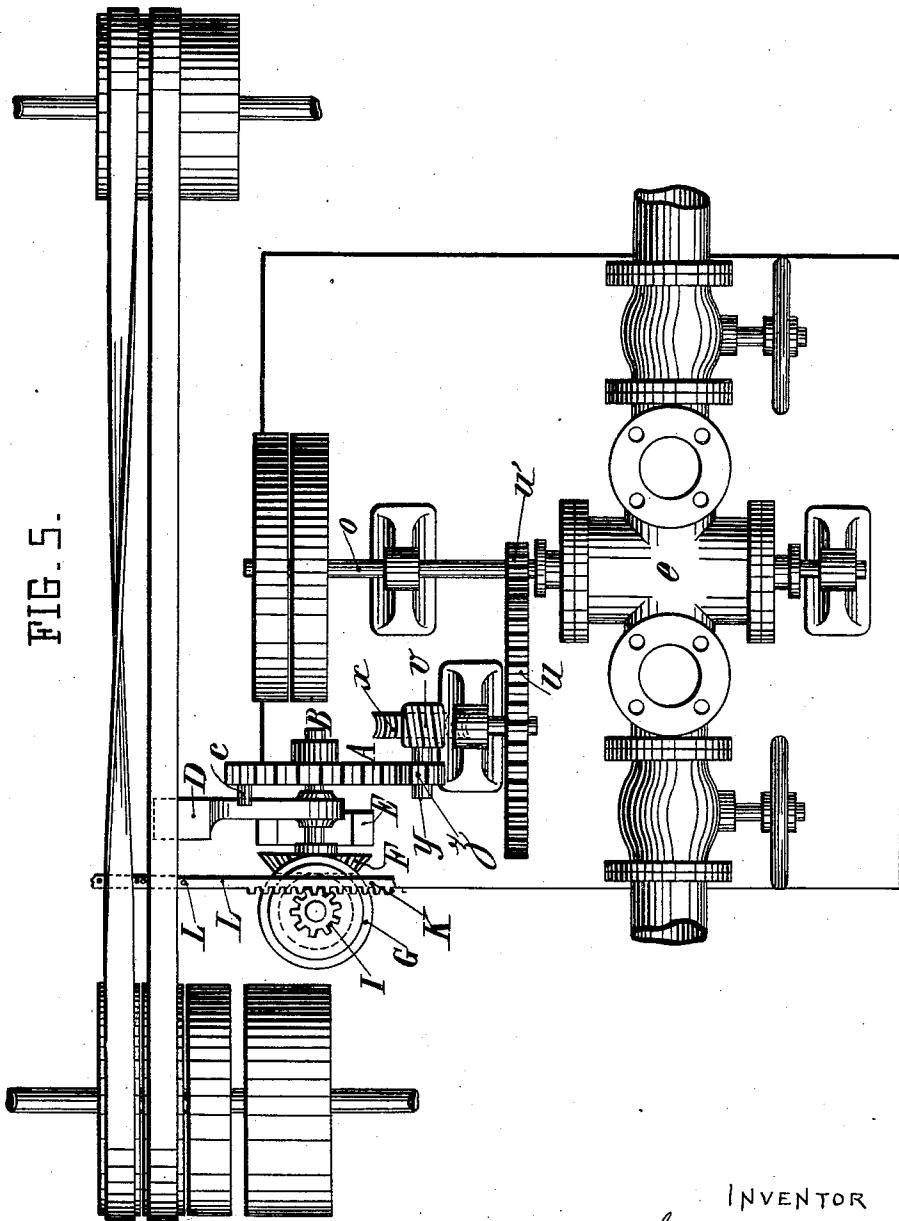

FIG. 5.

WITNESSES

*Charles E. Smith*  
*Otto Schrenk*

INVENTOR

*Edmond Masurel*

BY

*Briesen & Knauth*

ATTORNEYS.

(No Model.)

5 Sheets—Sheet 5.

E. MASUREL.  
APPARATUS FOR DYEING.

No. 523,047.

Patented July 17, 1894.

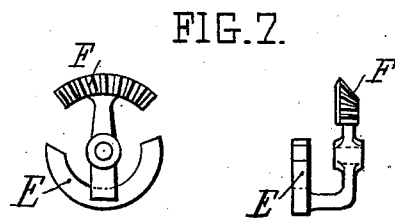
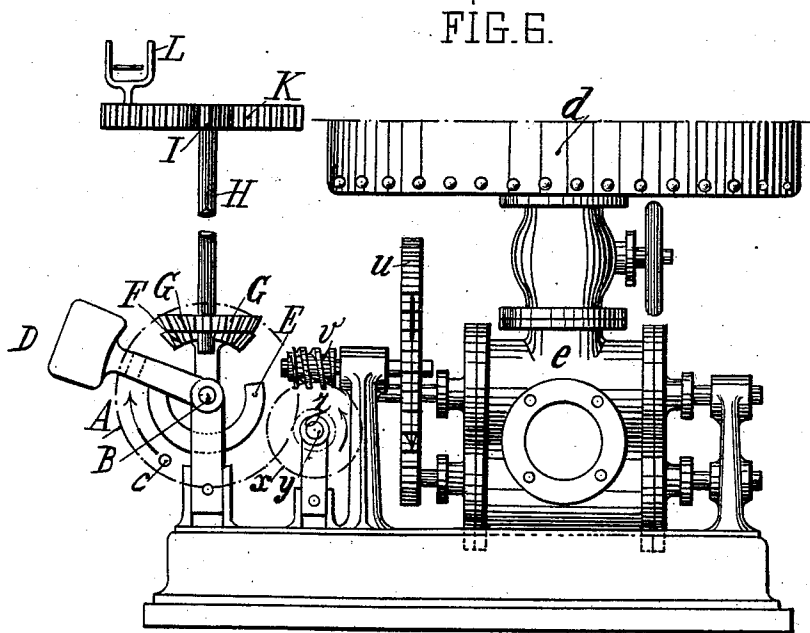

WITNESSES.

*Charles E. Smith*  
*Otto Schrenk*

INVENTOR

*Edmond Masurel,*  
BY *Briesen & Knauth.*

ATTORNEYS.

# UNITED STATES PATENT OFFICE.

EDMOND MASUREL, OF TOURCOING, FRANCE.

## APPARATUS FOR DYEING.

SPECIFICATION forming part of Letters Patent No. 523,047, dated July 17, 1894.

Application filed March 3, 1893. Serial No. 464,516. (No model.)

*To all whom it may concern:*

Be it known that I, EDMOND MASUREL, of the city of Tourcoing, (Nord,) France, have invented an Improved Apparatus for Dyeing all Kinds of Textile Materials, (any color,) of which the following is a full, clear, and exact description.

This invention relates to apparatus for dyeing all kinds of textile materials (any color, including indigo), the output being proportionate to the dimensions of the apparatus and about three times greater than that obtained by similar apparatus of the same capacity. The uniformity of result obtained is complete whatever may be the nature of the materials treated, whether consisting of combed wool, noils, waste or other textiles of any kind and whatever may be the shade to be obtained. The textile fibers are not injured as the steam used in heating is not brought in contact therewith, the ulterior treatment being consequently as easy as in the case of combed and unbleached materials.

My invention is illustrated in the accompanying drawings, forming part of this specification, Figure 1 of which represents a side view of my improved device; Fig. 2 a plan view of the same the vat *c* being shown removed; Fig. 3 cross-sections taken respectively on lines 1—2 and 3—4 of Fig. 1, of the improved dyeing apparatus. Figs. 4, 5 and 6 are side, plan and end views respectively of the pump and the automatic mechanism for reversing the same. Fig. 7 is a face and edge view of a detail of a portion of the pump reversing mechanism.

The dyeing apparatus consists of two dye vats *a*, *b*, between which is placed a wooden vat *c* having a metal vat *d* fitted in the bottom thereof and in free communication therewith. A reversible pump *e* passes the dye alternately from one vat to the other, the reversal of the action of the pump being effected by automatic tumbler mechanism hereinafter described. The dye is conveyed to and from the vats *a* and *b* through the pipes *ff'*, the upper pipes *f* being of conical, and the lower pipes *f'* of double conical form, an axial dotted line being shown passing through said pipes to clearly illustrate that they are conical in form, as shown in Fig. 1. The pipes are perforated so as to produce multiple

jets and owing to their peculiar form distribute the dye in a regular and uniform manner throughout the dye vats *a* and *b*. Above each of the lower conical pipes *f'* is a frame *g* which extends over the entire area of the vats *a* and *b* and is covered with wire gauze or trellis work upon which the material to be dyed is laid in a methodical manner in bundles or trunks, each composed of three, four, five, six, or more slivers which are laid one on the other until the two vats are filled. A second frame *g* similar to the first-mentioned is then laid upon the top of the materials to prevent them rising, the frame being held down by means of rods *s*, secured by pins *t* inserted in sockets mounted on the upper edges of the vat and passing through one of a series of holes in each rod, as shown in the cross-section on line 3—4 (Fig. 3) the vat being filled and the frame applied before the upper pipes *f* are placed in position.

The operation of the apparatus is as follows: The vats *a*, *b*, as well as the central vat *d* are first filled with water by turning on the cocks *h*, *n*, *n'*, after which the dye is introduced into the vat *d* through the funnel *k* which is provided with a stop-cock. The valve *h* is then closed and valves *i* and *j* opened whereupon the water from vat *a* is pumped into the vats *c*, *d*, and similarly for vat *b* by opening valves *i'* and *j'* after closing *i* and *j*. *p* is a float for indicating the level in vat *c* by means of a pointer *q* and scale *r*, the float being connected to the pointer by a cord or chain passing over two pulleys, as shown in Fig. 3. The textile materials to be dyed are next laid upon the grids *g* in the manner hereinbefore described and all the valves being closed the valves *n*, *n'*, are opened whereupon the dye bath is distributed upon the materials by the upper perforated conical pipes *f*. Heat is then applied by passing steam through the worm *l* in vat *d* which is provided with a thermometer *m* for indicating its temperature. The valves *i*, *i'*, are then opened at a given moment, the valves *n*, *n'*, being also open, whereupon the action of the pump *e* produces an active circulation between the vats *a*, *b*, in the direction of the arrow *L* for example, the temperature of the vat meanwhile being raised as desired, after which the action of the pump is reversed by means of

the gearing hereinafter described, so as to establish a circulation through the vats *a*, *b*, in the direction of the arrow B and afterward in the direction of arrow L<sup>x</sup> and so on until the dyeing operation is completed, which may be ascertained by again pumping the dye bath into the vats *c*, *d*, as before explained.

The reversal of the action of the pump *c* is effected by the device illustrated in Figs. 4, 5, 6 and 7. The pump is actuated from a shaft O (driven by a belt and provided with fast and loose pulleys to enable the action of the pump to be arrested when required) and upon this shaft O is keyed a pinion *v'* in gear with a wheel *u* whose shaft is provided with a worm *v* which gears with a worm wheel *x* whose shaft *y* has a pinion *z* in gear with a wheel A on a shaft B which thus receives very slow motion. Suppose the bath to be circulating in the direction of the arrow L<sup>x</sup> and the wheels to turn in the direction of the arrows. The wheel A carries a stud *c*, which at a given moment actuates a weighted tumbler arm D mounted loose on a shaft B and resting upon one end of a segmental abutment E (Fig. 7) formed in one with a bevel-toothed segment F' also loose on shaft B. The tumbler arm D has a notch R in which is fitted a removable piece against which the stud *c* abuts, so as to raise the tumbler arm until it passes beyond the vertical plane whereupon the tumbler falls over toward the right and then rests upon the other extremity of the segmental abutment E whereby the toothed segment F is caused to rotate and with it pinion G, shaft H and pinion I, so as to move rack K carrying the belt shipper forks L in such manner as to reverse the motion of the pump, the direction of rotation of the parts being then contrary to that of the arrows and the circulation through the vats being then in the direction of arrows B. The motion of wheel A being reversed, the stud *c* will throw the tumbler toward the left whereupon the direction of rotation and circulation will be again reversed and so on.

As the movement of the bar which carries the rack and belt shipping forks L must not exceed the breadth of the belt, the bar should be provided at each end with a stop by which its movement and that of the shaft H and segment F will be limited.

When the materials have been dyed they are removed from the vats either by hand or by means of a cord P passing over a pulley (see Fig. 1) and conveyed to the hydro-extractor and drying room.

The action of the apparatus is very simple and rapid and the temperature can always be readily verified by the thermometer placed on vat *d*. When a small quantity of material is to be treated, it may be placed in one only of the vats *a*, *b*, and by arranging a number of similar apparatus in series the dye bath may be collected in vat *c* and conducted to the adjoining apparatus.

The various parts of the apparatus, including the pump, may be made of enameled iron for the purpose of resisting the action of the acids and mordants contained in the dye baths.

I claim—

1. In an apparatus for dyeing all textile fabrics, the combination of two vats, conical perforated pipes for distributing the liquid over the mass to be dyed placed in the said vats, a reservoir and a heating vat in communication with said dye vats, heating said vat containing the bath and the distributor of the heat of the bath, a pump with automatic switching means connected therewith, for producing an automatic circulation in the lower part of one vat and the higher part of the other vat, substantially as described and set forth in the specification.

2. In a dyeing apparatus for textiles and the like, the combination of a series of dyeing vats, perforated conical pipes for supplying dye liquor thereto, a heating vat, a pump for causing a circulation between said dye vats and said heating vat, a tumbler operated by the pump, a segmental gear adapted to be operated by said tumbler and means substantially as described, connected with said segmental gear, for operating a belt shipper, substantially as and for the purposes specified.

The foregoing specification of my improved apparatus for dyeing all kinds of textile materials any color signed by me this 11th day of February, 1893.

EDMOND MASUREL.

Witnesses:

ROBT. M. HOOPER,  
ALBERT MOREAU.