



(19) **United States**

(12) **Patent Application Publication**

Yano et al.

(10) **Pub. No.: US 2006/0127268 A1**

(43) **Pub. Date: Jun. 15, 2006**

(54) **POWDER COMPACTING METHOD AND POWDER COMPACTING DEVICE**

Publication Classification

(76) Inventors: **Katsuhiko Yano**, Niigata-shi (JP); **Katsumi Sasagawa**, Niigata-shi (JP); **Masaki Matsui**, Niigata-shi (JP); **Masao Sasaki**, Toyosaka-shi (JP); **Heiji Yamada**, Niigata-shi (JP); **Masaru Kobayashi**, Sanjo-shi (JP); **Akihito Hanabusa**, Nagaoka-shi (JP); **Hideo Sato**, Nagaoka-shi (JP)

(51) **Int. Cl.**
B22F 3/02 (2006.01)
(52) **U.S. Cl.** 419/66

(57) **ABSTRACT**

This invention has been realized in order to obtain green compacts of a fixed height by pressure molding of material powder with a fixed gap between upper and lower punches. A powder compacting method of this invention performs a punch driving step wherein, after filling material powder in a cavity, the material powder filled in the cavity is pressure molded by using an upper punch and a lower punch, said punch driving step comprising a primary driving step of driving either one of the punches until the thickness of the cavity formed between the upper and lower punches becomes slightly greater than a target molding thickness, and a secondary driving step of measuring a gap between the upper and lower punches and driving either one of the punches while controlling it until the measured value reaches the target molding thickness.

Correspondence Address:
DARBY & DARBY P.C.
P. O. BOX 5257
NEW YORK, NY 10150-5257 (US)

(21) Appl. No.: **10/521,648**

(22) PCT Filed: **Jul. 25, 2002**

(86) PCT No.: **PCT/JP02/07537**

(30) **Foreign Application Priority Data**

Jul. 15, 2002 (JP) 2002-205621

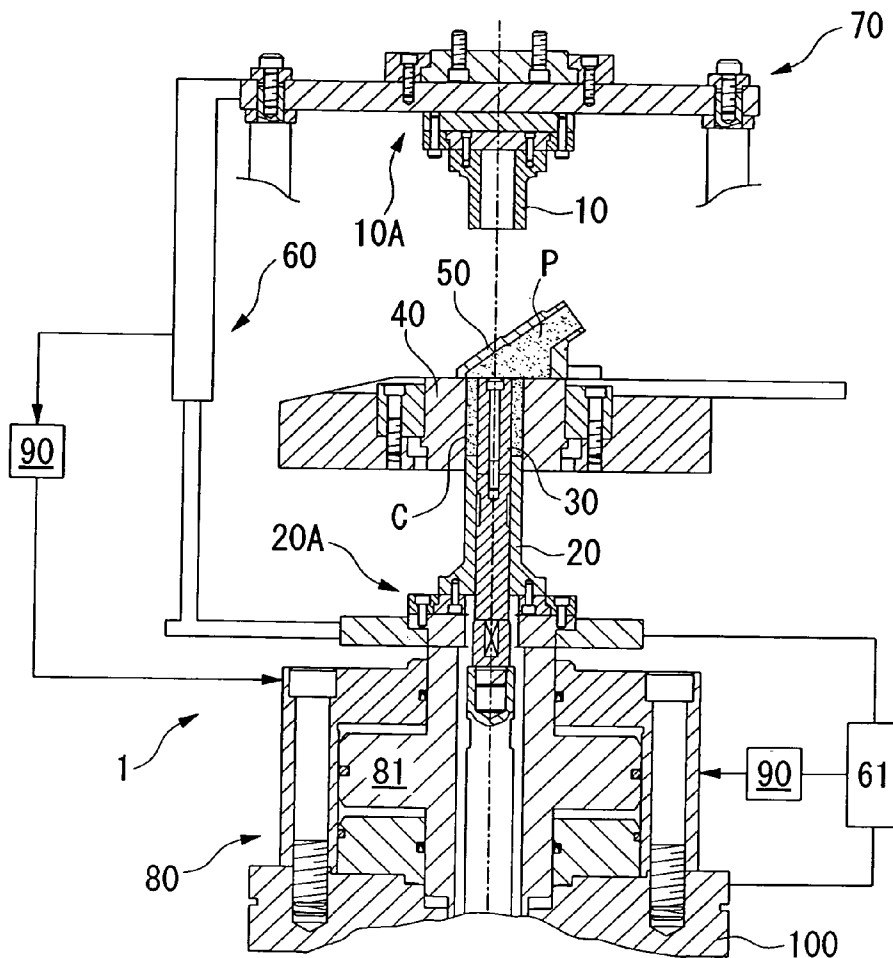

FIG. 1

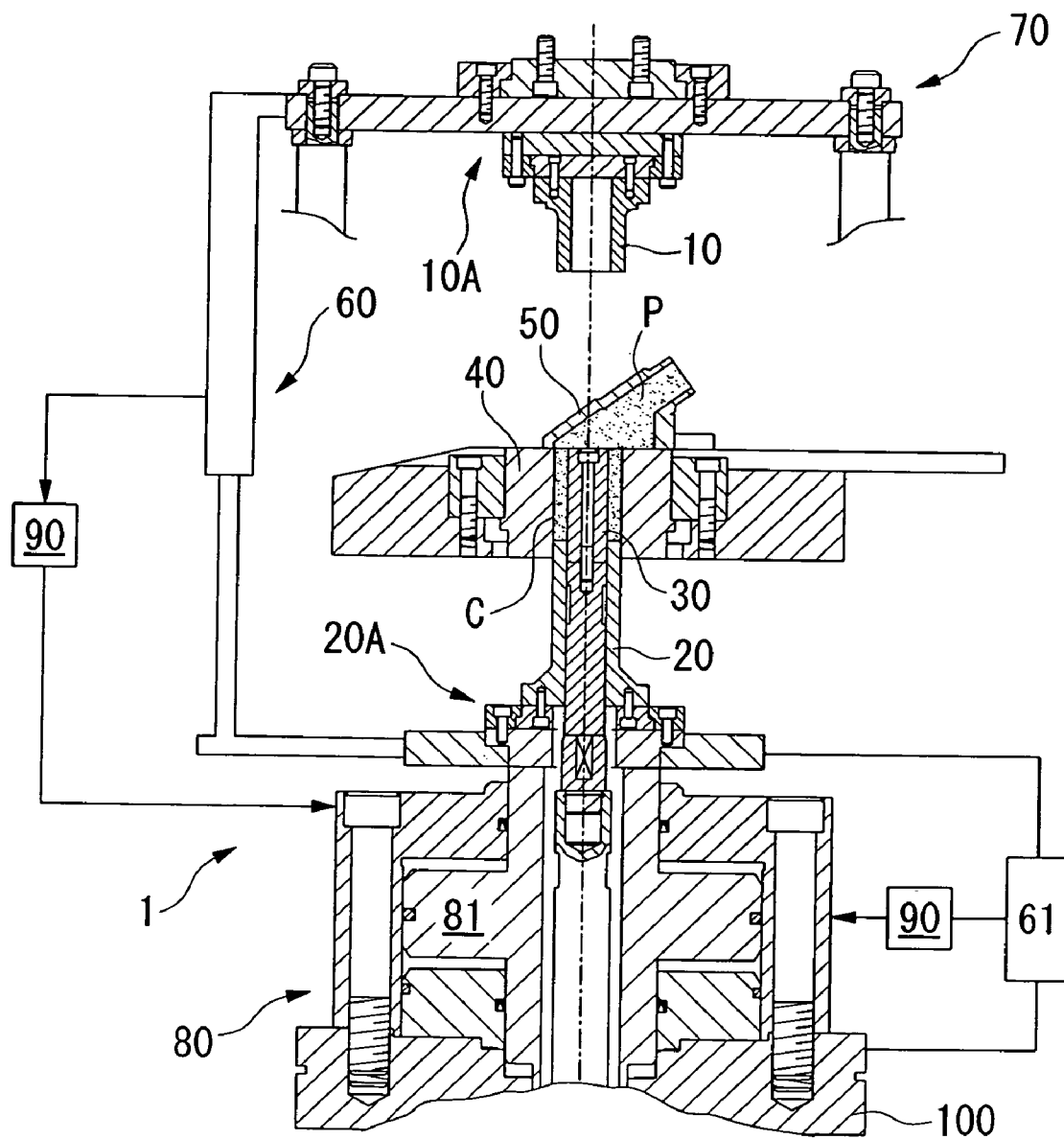

FIG. 2

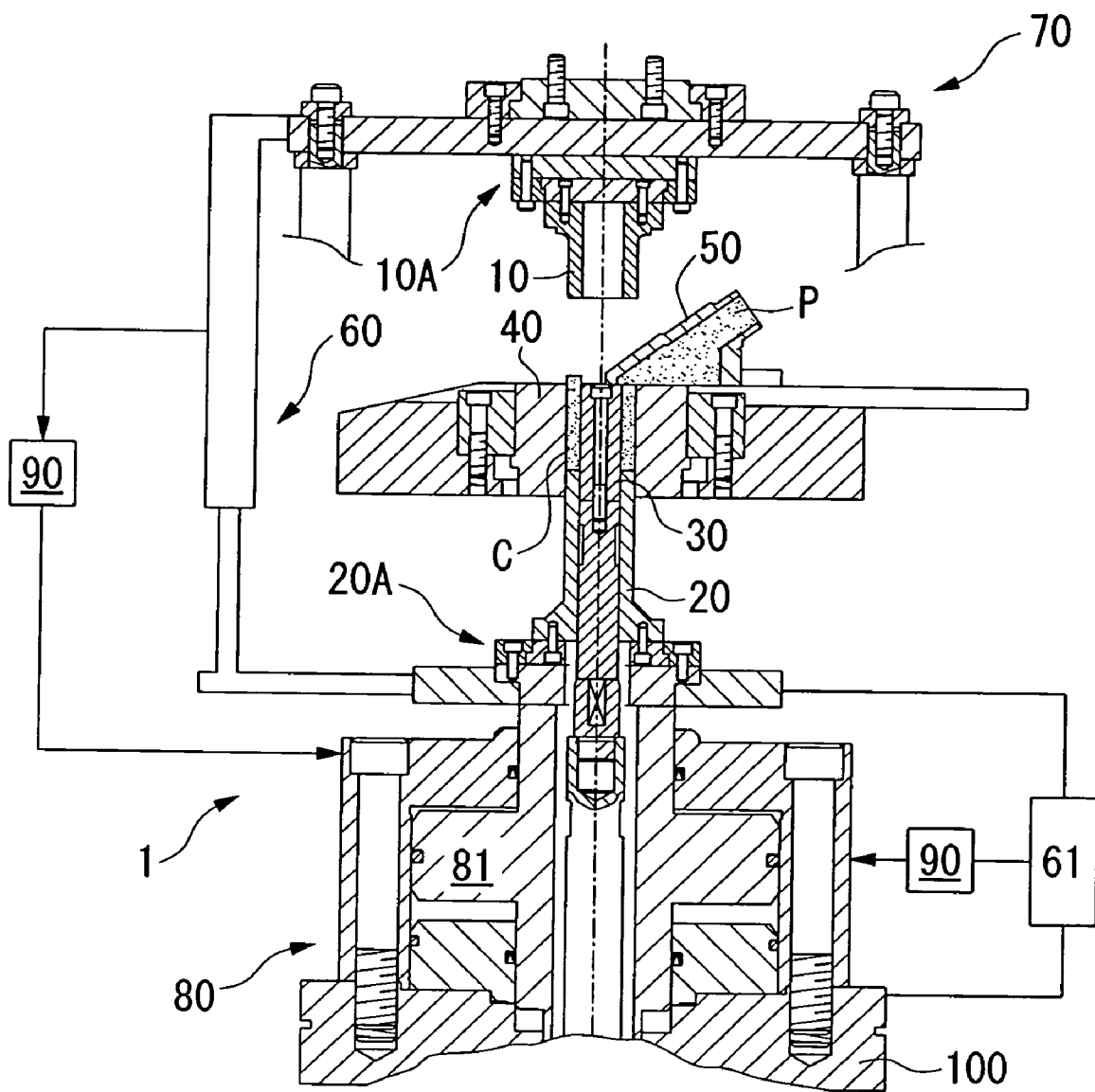

FIG. 3

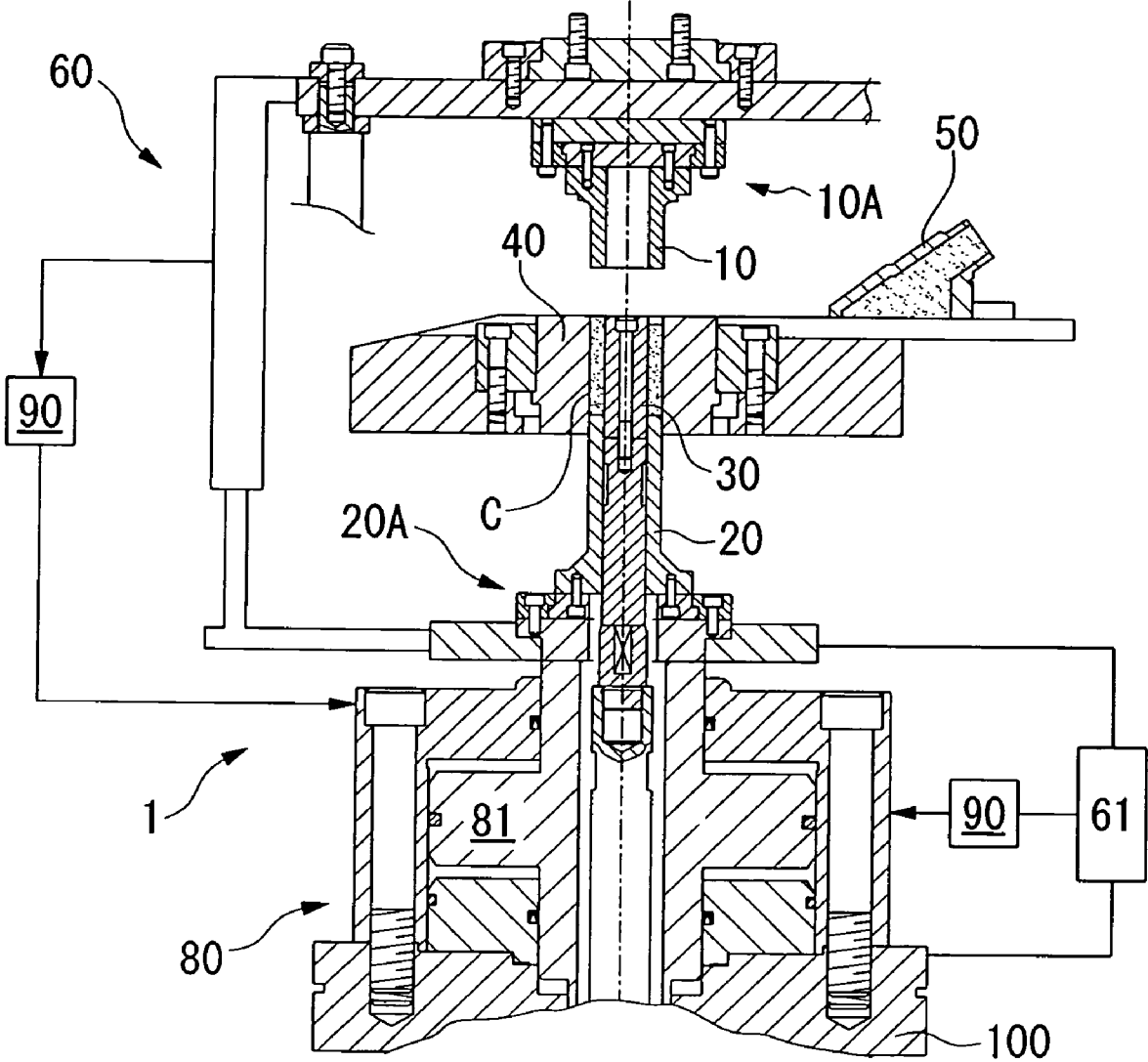

FIG. 4A

FIG. 4B

FIG. 4C

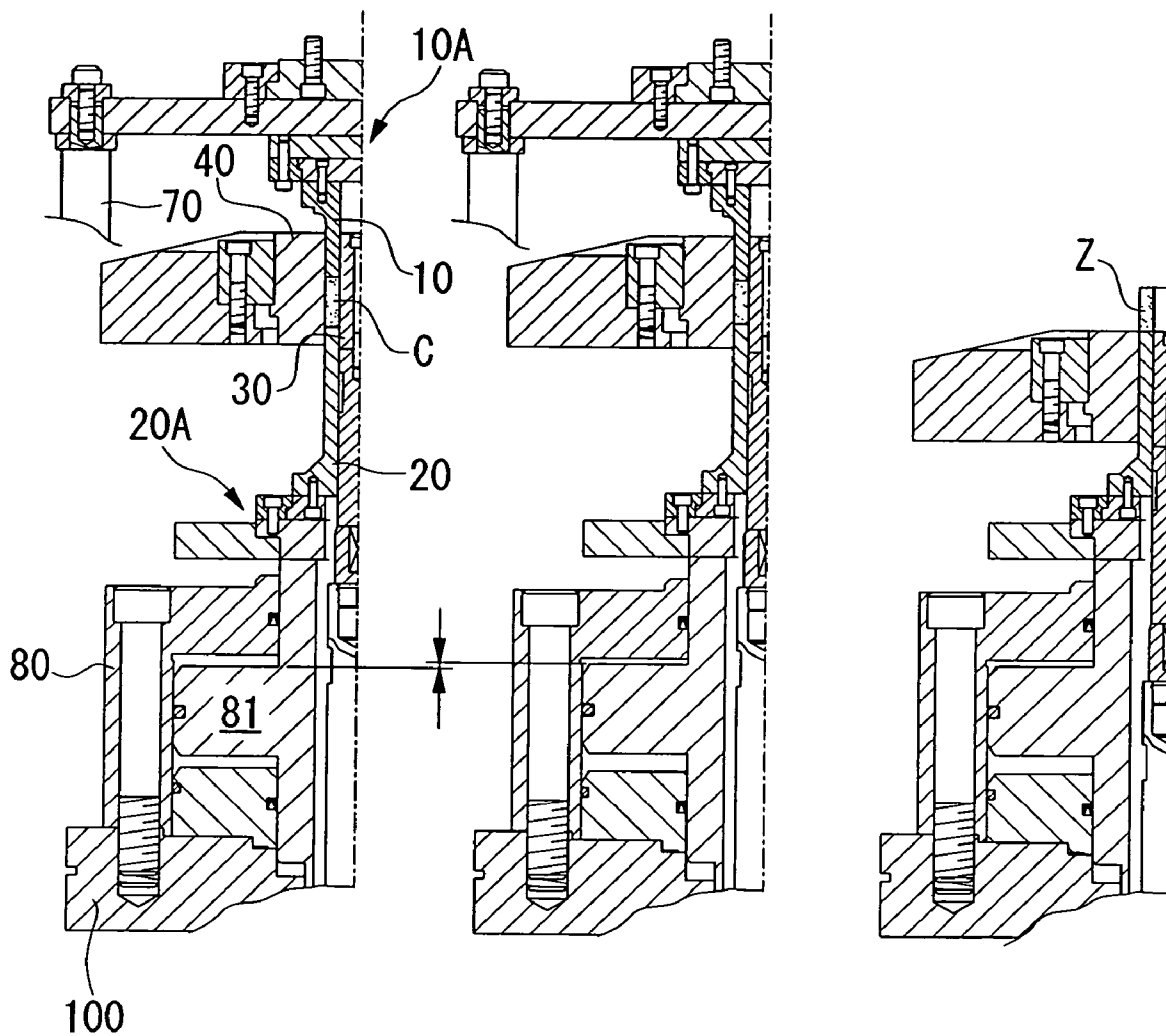

FIG. 5

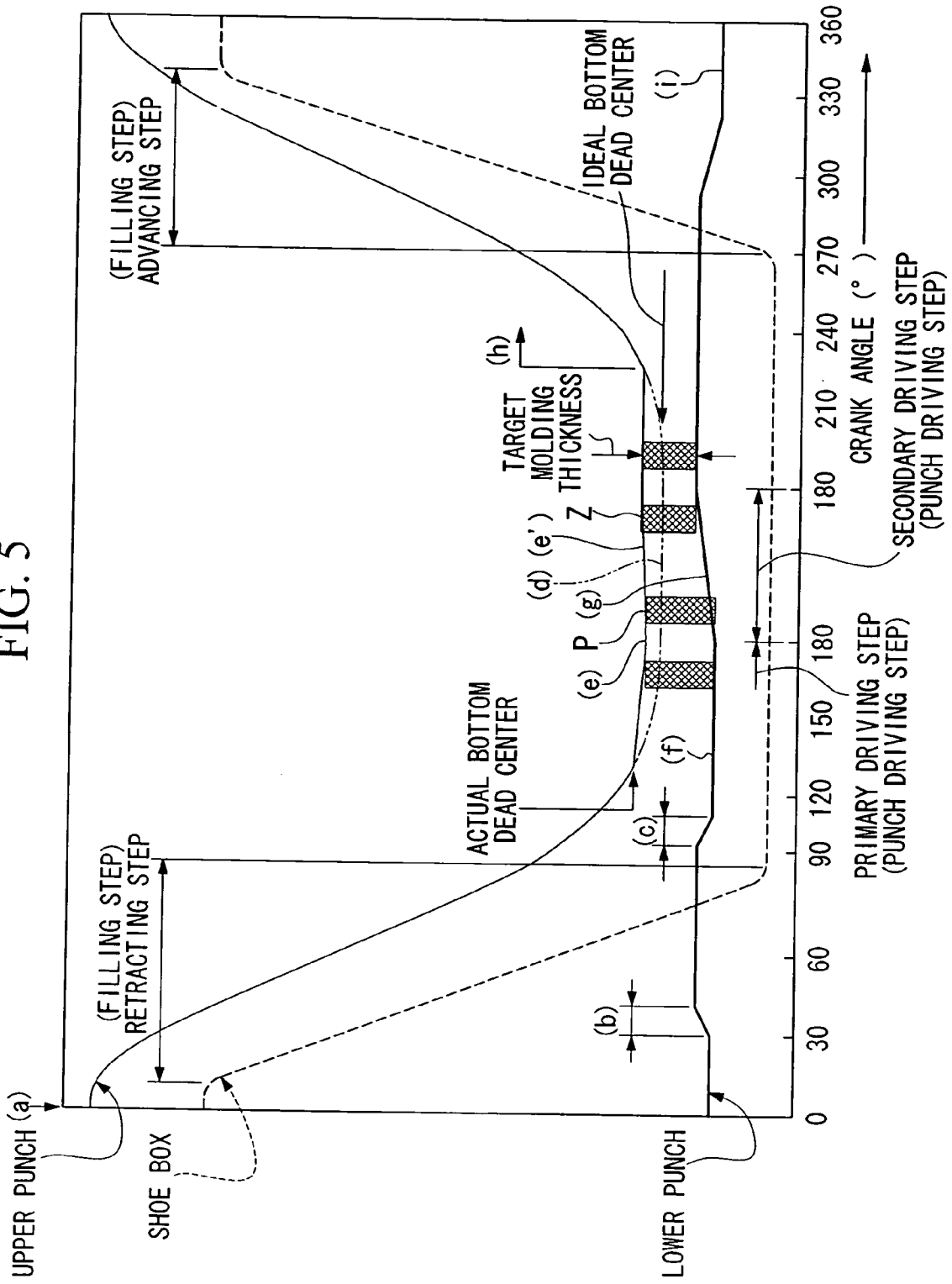

FIG. 6

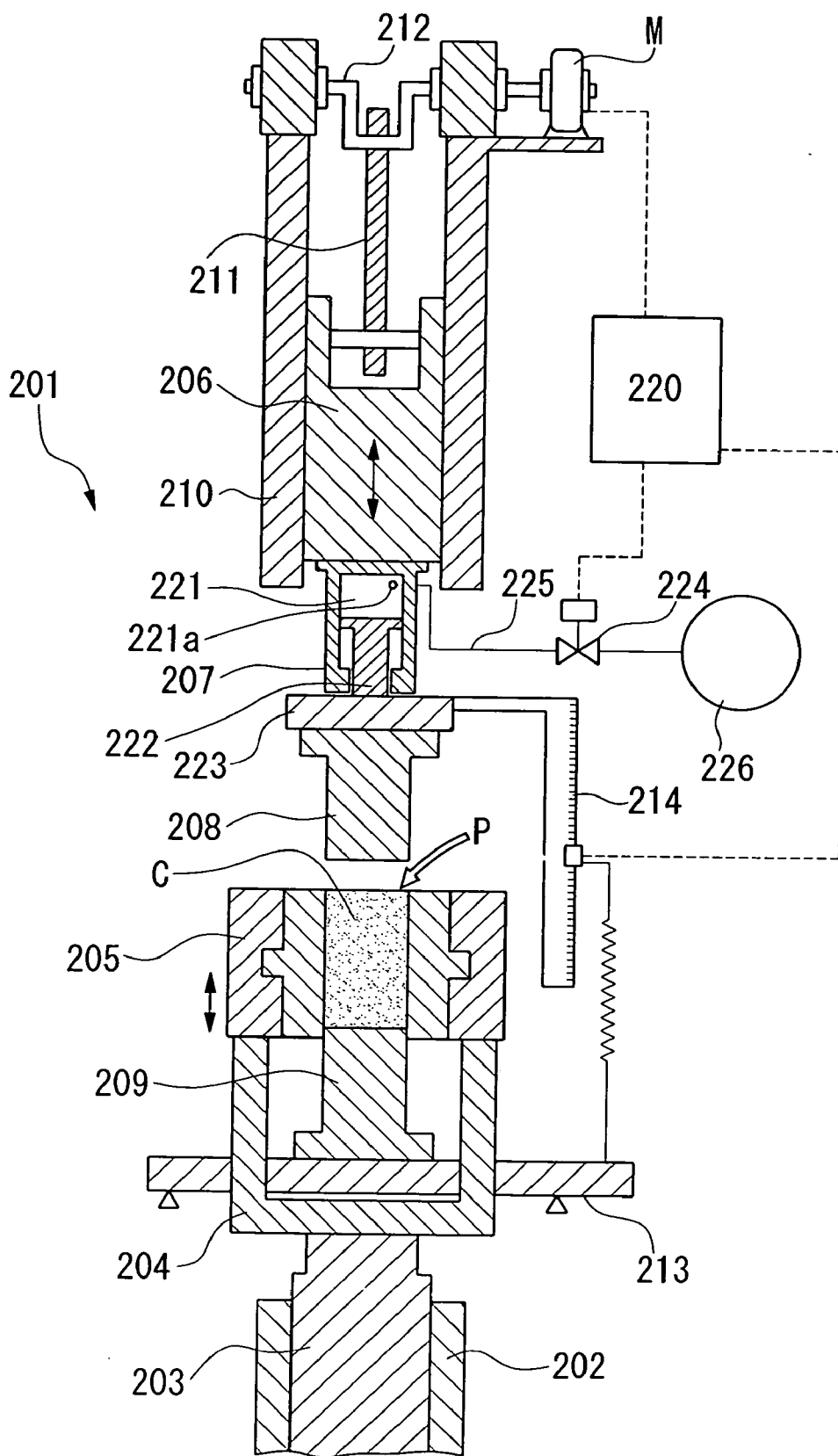

FIG. 7

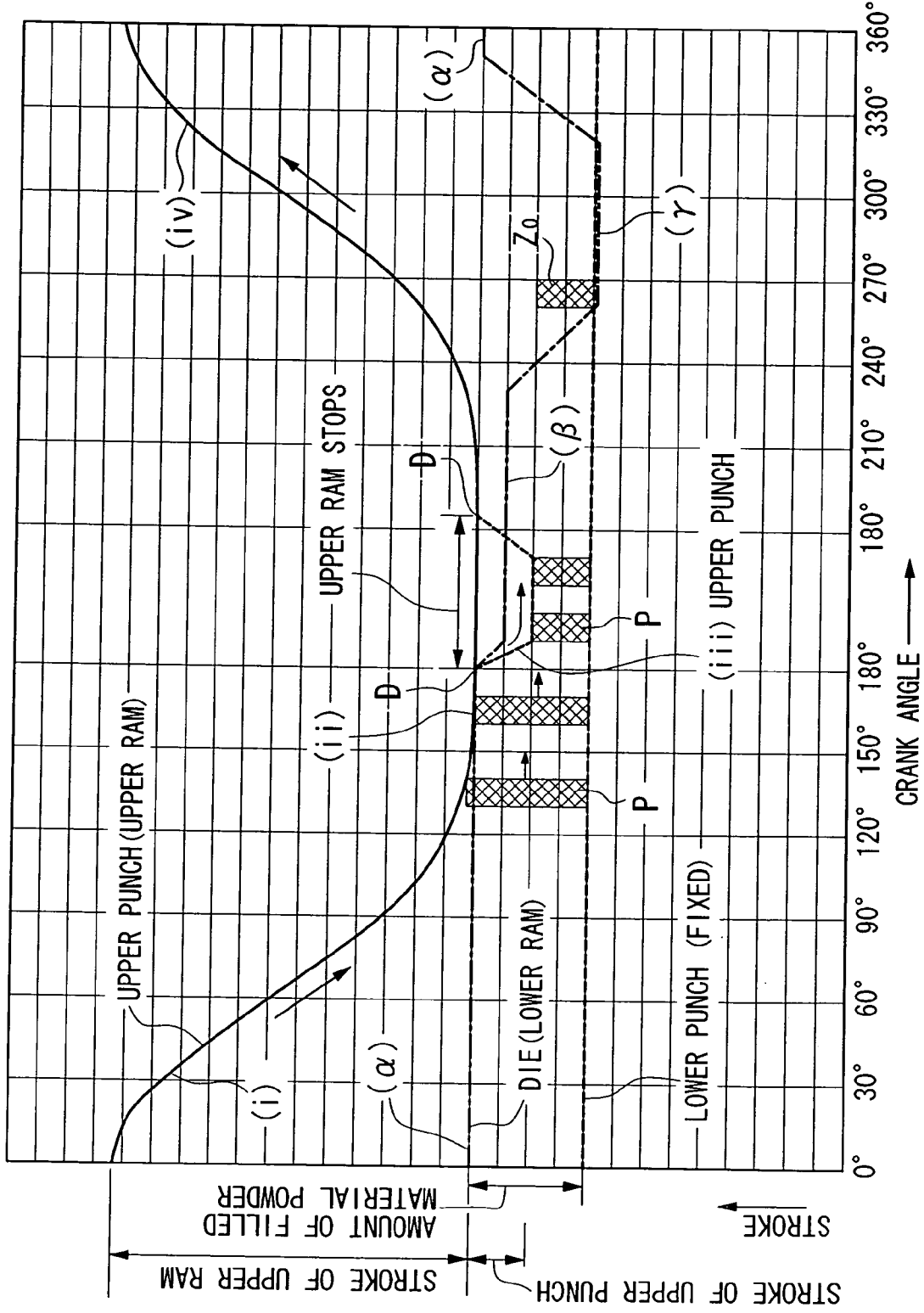

FIG. 8

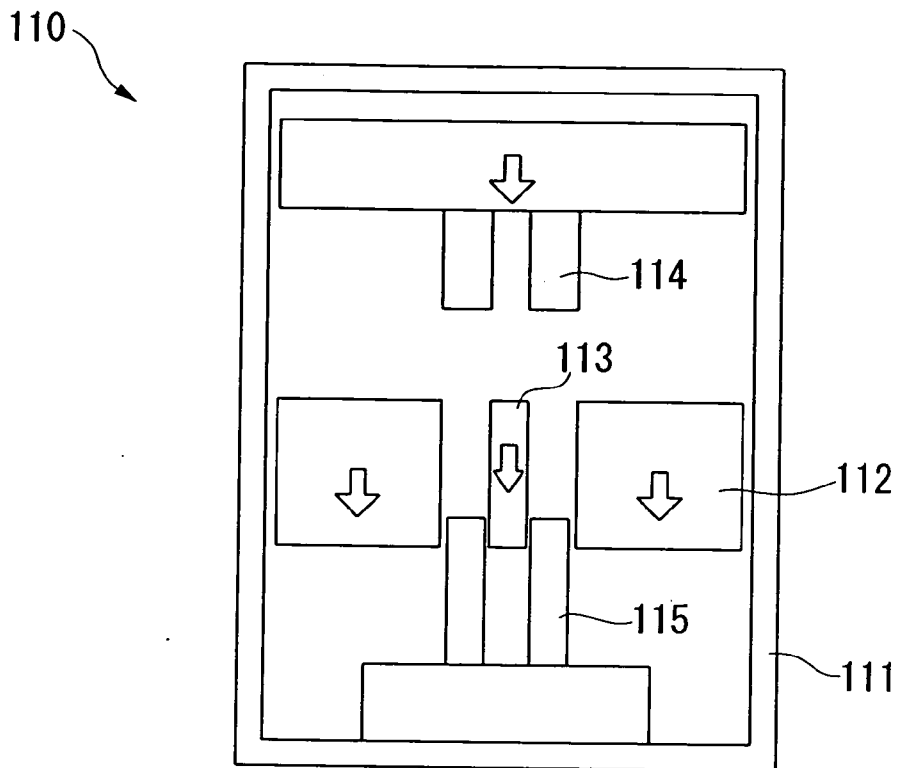
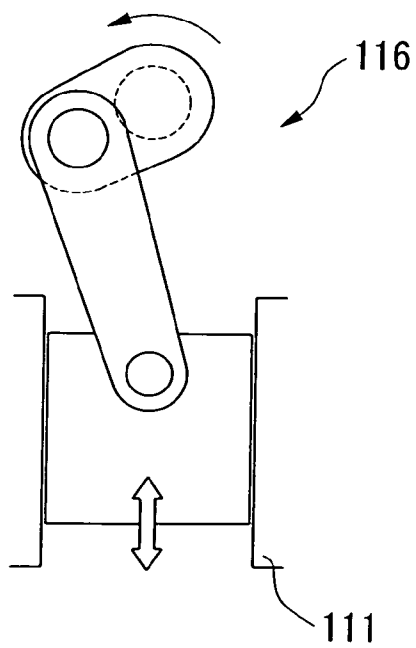

FIG. 9



POWDER COMPACTING METHOD AND POWDER COMPACTING DEVICE

BACKGROUND OF THE INVENTION

[0001] 1. Field of the Invention

[0002] This invention relates to a powder compacting method and a powder compacting device for a pressure molding of material powder.

[0003] 2. Description of Related Art

[0004] There is a conventional compacting device known as a machine press, which forms a green compact by pressure molding of material powder that has been filled in a cavity between an upper punch and a lower punch, the upper punch being driven by a crank or the like.

[0005] FIG. 8 shows an example of this type of machine press (powder compacting device) 110. The machine press 110 is a device for compacting a cylindrical green compact, and has a structure comprising a frame 111, which a cylindrical lower punch 115 for compacting the bottom end face of the green compact is fixed to, a die 112 for compacting the outer peripheral face of the green compact, a circular-headed rod-shaped core rod 113 for compacting the inner peripheral face, and a cylindrical upper punch 114 for compacting the top end face, being supported in the frame 111 so as to be able to move up and down.

[0006] FIG. 8 shows the machine press 110 using what is termed a withdrawal method, wherein, when the upper punch 114 presses the material powder by falling a predetermined distance, the die 112 and the core rod 113 begin to fall together with the upper punch 114, and, when the pressure molding of the material powder ends, the upper punch 114 rises while the die 112 and the core rod 113 fall further, extracting the green compact.

[0007] The upper punch 114 is moved up and down by a crank mechanism 116 shown in FIG. 9. In the crank mechanism 116, when the upper punch 114 has descended to its bottom dead point, the gap between the upper and lower punches 114 and 115 is set to the thickness of the green compact attempting to be obtained. That is, the machine press 110 is characterized in that a green compact of a fixed thickness can easily be obtained, since the movement of the upper punch 114 is mechanically restricted so that it descends to a predetermined position with regard to the fixed lower punch 115.

[0008] However, due to stretching and warping of the frame 111 that supports these members, and variations in the amount of material powder that is filled, there are cases where, even though the upper punch 114 has descended to its bottom dead point, the gap between the upper and lower punches does not reach the predetermined value, and as a result, the green compacts having a predetermined thickness are not obtained, and there variations in the thickness of the green compacts

[0009] This invention has been realized in consideration of the above problems, and aims to perform pressure molding with a fixed gap between the upper and lower punches, and obtain green compacts having a fixed thickness.

DISCLOSURE OF INVENTION

[0010] In order to achieve the above objects, this invention provides a powder compacting method for performing a

punch driving step wherein, after filling material powder in a cavity, the material powder filled in the cavity is pressure molded by using an upper punch and a lower punch, the punch driving step comprising a primary driving step of driving either one of the punches until the thickness of the cavity formed between the upper and lower punches becomes slightly greater than a target molding thickness of the green compact, and a secondary driving step of measuring a gap between the upper and lower punches and driving either one of the punches while controlling it until the measured value reaches the target molding thickness.

[0011] Alternatively, this invention is characterized in that the punch driving step of compacting the material powder in the cavity comprises a primary driving step of driving either one of the punches so that the upper and lower punches become closer to each other, and a secondary driving step of, when the gap between the upper and lower punches is greater than the target molding thickness due to the primary driving step, driving either one of the punches while controlling the gap between the upper and lower punches until it reaches the target molding thickness.

[0012] In this powder compacting method, in the punch driving step, either one of the upper and lower punches is driven in the primary driving step and the secondary driving step, and the other punch is fixed in the primary driving step and the secondary driving step.

[0013] According to this method, since the material powder can be pressure molded to the target molding thickness while measuring the gap between the upper and lower punches, even when the frame stretches or warps, a predetermined gap is maintained between the upper and lower punches, enabling green compacts having a fixed thickness to be obtained.

[0014] Moreover, when the gap between the upper and lower punches is set slightly larger than the target molding thickness in the primary driving step, the gap between the upper and lower punches is definitely adjusted in the secondary driving step. As a result, green compacts having the desired thickness can be reliably compacted.

[0015] Furthermore, in a case where, in the primary driving step, the gap between the upper and lower punches is set so that the cavity reaches the target molding thickness, even when the gap between the upper and lower punches does not reach the desired value in the primary driving step due to warping and the like of the device, the gap the upper and lower punches can be adjusted to be smaller in the secondary driving step. As a result, the thickness of the green compacts can be reliably kept below the predetermined value.

[0016] Moreover, it is preferable that the filling step is comprised of a forwarding step of moving forward over the cavity a shoe box, which can slide on a top face of the die and has an open bottom face, and a removal step of removing the shoe box from over the cavity; midway during the removal step, the lower punch is raised relatively with respect to the die, part of the material powder that is filled in the cavity is pushed onto the die, part of the material powder that was pushed onto the die is wiped away by the shoe box that is being removed, and, when the removal step has ended, the relative position of the lower punch with respect to the die is returned to its position prior to the removal step.

[0017] That is, since the density of the material powder filled in the cavity differs before and after the forwarding and removal of the shoe box, by driving the lower punch upwards and downwards during the filling step to change the depth of the cavity, the volume of material powder in the cavity is made different before and after the forwarding and removal of the shoe box, whereby the amount of material powder filled in the cavity can be made even. Therefore, since the filling amount of material powder in the entire cavity becomes even, by pressing with a fixed gap between the upper and lower punches, green compact having overall even density and thickness can be stably manufactured.

[0018] Furthermore, a powder compacting device of this invention for pressure molding of the material powder, filled in a cavity, between an upper punch and a lower punch, is characterized in that it comprises a primary drive device for driving one of the upper and lower punches upwards and downwards; a secondary drive device for minutely adjusting the top to bottom position of one of the upper and lower punches; a measuring unit for determining the gap between the upper and lower punches; and a control section for feeding back a measurement result of the measuring unit, and controlling the secondary drive device so that the measurement result reaches a target value.

[0019] According to this invention, the gap between the upper and lower punches is measured, and the material powder can be pressure molded until it reaches the target molding thickness; therefore, even when the frame has stretched or warped, a predetermined gap can be maintained between the upper and lower punches, enabling green compacts having a predetermined thickness to be obtained.

[0020] In the powder compacting device, one of the upper and lower punches can be driven by the primary drive device and the secondary drive device. Alternatively, one of the upper and lower punches may be driven by the primary drive device and the other is driven by the secondary drive device.

[0021] In this case, if the constitution is such that the upper punch is driven by the secondary drive device, it becomes easy to fix the lower punch while allowing the die to move upwards and downwards, making it possible to easily provide a powder compacting device which performs a withdrawal method.

[0022] Furthermore, if the constitution is such that the lower punch is driven by the secondary drive device, the step of making even the amount of powder filled in the cavity by driving the lower punch at the time of filling the cavity by using the shoe box can be carried out using the secondary drive device, enabling the device to be simplified.

BRIEF DESCRIPTION OF DRAWINGS

[0023] FIG. 1 is a cross-sectional view of primary parts of a powder compacting device according to an embodiment of this invention, and shows a filling step.

[0024] FIG. 2 is a diagram showing an upper punch raising step in a shoe box removal step in the powder compacting device shown in FIG. 1.

[0025] FIG. 3 is a diagram showing the state when the lower punch has been lowered and the material powder has been filled in the powder compacting device shown in FIG. 1.

[0026] FIG. 4A is a diagram showing a powder compacting method according to an embodiment of this invention, and shows a cross-sectional view of a machine driving step for lowering the lower punch to its bottom dead point.

[0027] FIG. 4B is a diagram showing a powder compacting method according to an embodiment of this invention, and shows a cross-sectional view of a machine driving step for lowering the lower punch to its bottom dead point.

[0028] FIG. 4C is a diagram showing a powder compacting step according to an embodiment of this invention, and shows a cross-sectional view of a step of extracting compacted green compacts from a die.

[0029] FIG. 5 is an operation line diagram showing the operations of upper and lower punches and a shoe box in steps of powder compacting.

[0030] FIG. 6 is a cross-sectional view of primary parts of a powder compacting device according to another embodiment of this invention.

[0031] FIG. 7 is a work step diagram showing a powder compacting method of this invention using the powder compacting device shown in FIG. 7.

[0032] FIG. 8 is a schematic diagram showing the schematic arrangement of a conventional powder compacting device.

[0033] FIG. 9 is a schematic diagram showing one example of an upper punch drive mechanism in a powder compacting device.

BEST MODE FOR CARRYING OUT THE INVENTION

[0034] Next, embodiments of the invention will be explained with reference to figures.

[0035] FIGS. 1 to 4 show primary parts of a powder compacting device 1 according to a first embodiment of this invention, in which reference numeral 10 represents an upper punch, reference numeral 20 represents a lower punch, reference numeral 30 represents a core rod, reference numeral 40 represents a die, reference numeral 50 represents a shoe box, reference numeral 60 represents a measuring unit (linear scale for correcting bottom dead point) for measuring the distance L between the upper and lower punches, and P represents material powder.

[0036] A hole for compacting 40a is provided in the die 40, and the core rod 30 is arranged in the center of the hole for compacting 40a. The cylindrical space formed between the hole for compacting 40a and the core rod 30 is sealed by the cylindrical lower punch 20 that fits from below and the cylindrical upper punch 10 that fits from above, thereby forming a cavity C. The material powder P is pressed inside the cavity C compacting a green compact Z in the shape of the cavity C.

[0037] The shoe box 50 that fills the material powder P into the cavity C is shaped like a box with an open bottom face, and slides back and forth (left and right as viewed in the diagrams) with its bottom face touching the top face of the die 40. The material powder P is supplied to the shoe box 50 from an unillustrated hopper, proceeding to the position

shown in **FIG. 1** and positioned above the cavity C, which it fills by dropping the material powder P held inside it into the cavity C.

[0038] The upper punch **10** is fixed via a frame **70** to an upper punch holding member **10A**, which is held so as to move upwards and downwards with respect to the base **100**, and is a cylindrical member that can move upwards and downwards in a single piece with the upper punch holding member **10A**. The upper punch holding member **10A** that the upper punch **10** is fixed to is moved upwards and downwards mechanically by a mechanism (primary drive device) such as, for instance, the crank mechanism shown in **FIG. 8**, a knuckle press, a cam mechanism, or the like. Then, by lowering the upper punch **10** to the bottom dead point, pressure can be applied to the material powder that is filled in the cavity C.

[0039] The lower punch **20** is a cylindrical member fixed to a lower punch holding member **20A**, and can be moved upwards and downwards in a single piece with the lower punch holding member **20A** by a piston **81** of a fluid pressure cylinder (secondary drive device) **80**, which is fixed to the base **100**. A linear scale for correcting filling amount **61** is attached between the lower punch **20** (the lower punch holding member **20A**) and the base **100**, and detects the position of the lower punch **20** with respect to the base **100**. A control section **90** receives a detect signal from the linear scale for correcting filling amount **61** and controls the fluid amount of the fluid pressure cylinder **80**, enabling the piston **81** i.e. the lower punch **20** to be moved to a given position.

[0040] A linear scale for correcting bottom dead point (measuring unit) **60** is attached between the upper punch holding member **10A** and the lower punch holding member **20A**, and outputs as a signal the measurement obtained by measuring the distance between the upper punch holding member **10A** and the lower punch holding member **20A**, i.e. the gap between the upper punch **10** and the lower punch **20**. The signal is input to the control section **90**, which controls the fluid amount of the fluid pressure cylinder **80** so that the measurement attains a preset target value. The target value is the value at which the thickness of the cavity C reaches the target molding thickness between the upper punch **10** and the lower punch **20**.

[0041] Furthermore, a shoe box position detecting signal showing the position of the shoe box **50** is output from an unillustrated shoe box position detecting sensor, and input to the control section **90**.

[0042] Subsequently, a powder compacting method using the powder compacting device having the constitution described above will be explained with reference to **FIG. 5**. In the operation line diagram shown in **FIG. 5**, the horizontal axis shows the angle of the crank that mechanically drives the upper punch **10**, and the vertical axis shows the positions of the upper and lower punches and the shoe box, the upper end of the vertical axis being the front side of the shoe box **50** and the upper end of the upper and lower punches.

[0043] At the time of pressure molding, the upper punch **10**, the lower punch **20**, and the die **40** are arranged at their initial positions.

Filling Step

[0044] The shoe box **50** is moved forward (advancing step) and opened over the cavity C as shown in **FIG. 1**, filling it with the material powder P. At this time, the shoe box **50** moves from the rear (right side of **FIG. 1**) to the front (left side of **FIG. 1**) to the position shown in **FIG. 1**, opening above the rear side of the cavity C at first and then opening over the front side. Therefore, the shoe box **50** is open above the rear side of the cavity C for a relatively long time and supplies the material powder P therein, and consequently, the material powder P is filled more densely at the rear side.

[0045] Subsequently, the shoe box **50** is retracted and removed from the cavity C as shown in **FIG. 2** (retracting step); at the start of this retracting step, the lower punch **20** is raised above the die **40** ((b) in **FIG. 5**), that is, the shoe box is retracted and the excess material powder P on the die **40** and the core rod **30** is wiped away by the wall section of the front side of the shoe box **50**; by raising the lower punch **20** after retracting the wall section further back than the front side of the cavity C, some of the material powder P filled in the rear side of the cavity C is pushed onto the die **40**, and, at the same time, wiped away by the shoe box **50**, whereby the front and rear sections correct the amount of the material powder P filled in the cavity C. As a result, there is a large volume of material powder P in the front side of the cavity C, and a smaller volume of material powder P in the rear side of the cavity C.

[0046] Moreover, as shown in **FIG. 3**, after the shoe box **50** has been completely removed from the top of the cavity C, the raised lower punch **20** is lowered with respect to the die **40**, and returned to its initial position ((c) in **FIG. 5**). Consequently, the material powder P in the front side of the cavity C that was pushed onto the die **40** is returned into the cavity C (into the die **40**), and the material powder P is filled into the cavity C at a high filling height at the front side and a low filling height at the rear side.

[0047] That is, since the material powder is filled into the cavity by naturally falling from the shoe box, it has relatively high density in the rear side of the cavity, where the shoe box is open for a long time. Therefore, when filled entirely at the same height, a large amount of the material powder is filled at the high-density rear side of the cavity, leading to unevenness in the density of the green compact that is obtained by performing the pressure molding of the material powder P that was filled in this manner.

[0048] In contrast, in this embodiment, the filling height of the material powder is high at the low-density front side and low at the high-density rear side, eliminating unevenness in the amount of material powder filled along the progression direction of the shoe box, and evenly filling the material powder P in the entire cavity C.

Punch Driving Step

[0049] **FIGS. 4A** to **4C** shows steps of a pressure molding performed while driving the upper and lower punches.

Primary Driving Step

[0050] Firstly, as shown in **FIG. 4A**, with the lower punch **20** in a fixed state, the upper punch **10** is lowered to its bottom dead point (mechanical movement limit position), compressing the material powder P in the cavity C. This device is designed so that the upper punch **10** will descend

to the position of the double-short-dash and one-long-dash line (ideal bottom dead point) shown at (d) in FIG. 5, but in fact the upper punch 10 can be lowered only as far as the position shown by the solid line at (e) in FIG. 5 due to warping and the like of the device.

[0051] The ideal bottom dead point (for design purposes) of the upper punch 10 is set between the upper punch 10 and the lower punch 20 which is fixed in its initial position ((f) in FIG. 5), and is such as to form a cavity C having a thickness that is approximately one mm greater than the target molding thickness of the green compact. That is, in a case where the device does not warp or stretch and the upper punch 10 falls to its ideal bottom dead point, the thickness of cavity C would still be greater than the target molding thickness, and would not compact green compacts that have smaller thicknesses than the target molding thickness.

Secondary Driving Step

[0052] Next, as shown in FIG. 4B, the crank for mechanically driving the upper punch 10 is stopped and the upper punch 10 is fixed at its bottom dead point, and the fluid pressure cylinder 80 is driven to raise the lower punch 20 from its initial position so that the thickness of the cavity C reaches the target molding thickness ((g) in FIG. 5). The lower punch 20 is moved at this time by feeding back the measurement obtained by the linear scale for correcting bottom dead point 60.

[0053] In other words, the control section 90, which received the detect signal from the linear scale for correcting filling amount 61, controls the fluid amount of the fluid pressure cylinder 80, and measures the gap between the upper and lower punches using the linear scale for correcting bottom dead point 60, and, when the value reaches the target molding thickness, the control section 90 drive-controls the fluid pressure cylinder 80 and raises the lower punch 20.

[0054] At that time, the rise of the lower punch 20 may lift the upper punch 10 slightly ((e') in FIG. 5), but since the measurement of the gap between the upper and lower punches is fed back before raising the lower punch 20, the lower punch 20 is driven and insufficient descent of the upper punch 10 is corrected until the thickness of the cavity C reaches the target molding thickness, so that the thickness of the green compacts achieves the target molding thickness.

[0055] Then, as shown in FIG. 4C, the upper punch 10 is raised ((h) in FIG. 5), the core rod 30 and the die 40 are lowered with respect to the lower punch 20, and the compacted green compact Z is extracted from the die 40. Furthermore, the lower punch 20 that was raised in the secondary driving step is returned to its initial position ((i) in FIG. 5), ready to compact the subsequent green compact.

[0056] As described above, it is possible to obtain a green compact Z that has been entirely compacted to the target molding thickness at even density.

[0057] Incidentally, the shapes, combinations, and the like, of the parts in the embodiment described above represent one example, and may be modified in various ways without deviating from the main points of this invention. In the embodiment shown in the diagrams, in the primary driving step, the upper punch 10 is driven mechanically, and in the secondary driving step, the lower punch 20 is driven by the fluid pressure cylinder 80, but the constitution may be

reversed so that, in the primary driving step, the lower punch is driven mechanically, and in the secondary driving step, the upper punch is driven by the fluid pressure cylinder 80. Furthermore, in the embodiment described above, the fluid pressure cylinder 80 is used as the secondary drive device, but various drive devices can be used, such as an electrical servo motor or the like.

[0058] Furthermore, in the embodiment described above, the thickness of the cavity C in the primary driving step is greater than the target molding thickness; however, by setting the upper and lower punch positions so that the thickness of the cavity in the primary driving step becomes the target molding thickness, the secondary driving step need only be executed when warping and the like of the device has caused the thickness of the cavity to deviate from the target molding thickness, thereby simplifying the control of the device. In this compacting method, when the thickness of the cavity is smaller than the target molding thickness in the primary driving step, the compacted green compact is smaller than the desired thickness, but this is effective in cases where, for instance, sufficient precision is achieved when the thicknesses of the green compacts are less than a fixed value.

[0059] Subsequently, a second embodiment of this invention will be explained with reference to FIGS. 6 and 7. In the CNC press device 201 shown in FIG. 6, a die 205 having a cavity C, which the material powder P is filled into, and an upper punch 208 are driven upwards and downwards, while the lower punch 209 is always fixed.

[0060] The die 205 is attached to a lower slider 203, which slides inside a downward guide 202 via a lower ram 204, and is moved upwards and downwards by a driving unit (unillustrated) such as a ball screw mechanism. Below the die 205, the lower punch 209 is fixed to a securing plate 213 and is arranged so as to fit into the cavity C from below.

[0061] Above the lower punch 209, the upper punch 208, which can enter and exit the cavity C, coaxially faces the lower punch 209. The upper punch 208 is attached to an upward guide 210, which slides within an upper slider 206, via an upper ram 207 comprising a hydraulic cylinder 201 and a hydraulic piston 222, which an upper punch plate 223 is attached to. The upper slider 206 connects via a link mechanism 211 to a crank shaft 212, which is rotated by a drive motor M (primary drive device). The drive motor M is a servo motor in which its drive and stop are controlled by a program stored in a computer (control section) 220.

[0062] The upper ram 207 has a hydraulic cylinder 221 that is fixed to the upward guide 210, and the hydraulic piston 222 that is attached to the upper punch plate 223. A hydraulic supply hole 221a is provided in the hydraulic cylinder 221, and oil pressure is supplied from a hydraulic unit 26 (secondary drive device) via a hydraulic supply pipe 25 connected here. The oil pressure is controlled by a hydraulic servo gauge 224, which is provided at the hydraulic supply pipe 25 and is driven by the computer 220.

[0063] That is, in the upper ram 207, the entirety is driven upwards and downwards by the drive motor (primary drive device) M, and in addition, the hydraulic piston 222 is driven upwards and downwards by the hydraulic unit (secondary drive device).

[0064] Moreover, the CNC press device 201 comprises a linear scale (measuring unit) 214 for measuring the gap

between the upper punch plate 223 and the securing plate 213, provided between an upper punch plate 223 where the upper punch 208 is fixed and the securing plate 213 where the lower punch 209 is fixed. The measurement of this linear scale 214 is input to the computer 220, and the computer 220, which the measurement has been input to, outputs a drive signal for the drive motor M and a drive signal for the hydraulic servo gauge 224 in accordance with the program.

[0065] A powder compacting method using the CNC press device 201 of the constitution described above will be explained with reference to FIG. 7. In the operation line diagram shown in FIG. 7, the horizontal axis shows the angle of the crank axis 212 that mechanically drives the upper punch 208, and the vertical axis shows the top and bottom directions of the upper and lower punches 208 and 209 and the die 205.

Punch Driving Step

[0066] Firstly, at the time of pressure molding, the upper punch 208, the lower punch 209, and the die 205 are arranged at their respective initial positions.

Primary Driving Step

[0067] Firstly, the lower punch 209 and the die 205 are fixed (a), and the upper ram 207 is lowered to its bottom dead point (mechanical movement limit position) D, sealing the cavity C which the material powder P is filled in (i).

Secondary Driving Step

[0068] When the crank angle reaches 180 degrees, this being the angle of the upper ram 207 at the bottom dead point D, in accordance with the program in the computer, the drive motor M that mechanically drives the upper ram 207 stops, stopping the fall of the upper punch 208 resulting from the fall of the upper ram 207 (ii). Then, when the upper ram 207 stops falling, the hydraulic servo gauge 224 is driven and oil pressure is supplied to the hydraulic cylinder 221, lowering the hydraulic piston 222, i.e. the upper punch 208, until the measurement from the linear scale 214 reaches a set value (the value at which the thickness of the cavity C reaches the target molding thickness) (iii). Moreover, simultaneous to the descent of the upper punch 208 resulting from the oil pressure, the die 205 is lowered by one-half of a descending stroke of the upper punch 208 (β), whereby the material powder P in the cavity C is pressed from above and below, receiving an even pressing force so that it is compressed at even density in the upward and downward directions.

[0069] Then, when the measurement of the linear scale 214 reaches the set value, the j220 controls the hydraulic servo gauge 224 so as to raise the j22 and the upper punch 208, restart the drive motor M, raise the upper ram 207 and the upper punch 208 (iv), and lower the die 205 (γ). Consequently, a product (green compact) Z_0 compacted to the target molding thickness is extracted from the die 205 (cavity C) and mounted on the lower punch 209.

[0070] As described above, a product Z_0 compacted to the target molding thickness can be obtained.

[0071] Incidentally, the shapes, combinations, and the like, of the parts in the embodiment described above represent one example, and may be modified in various ways without deviating from the main points of this invention. In

the embodiment shown in the diagrams, the lower punch 209 is fixed, and in the primary driving step and secondary driving step the upper punch 208 is driven, but the constitution may be reversed so that the lower punch is driven in both driving steps while the upper punch is fixed.

[0072] Furthermore, in the embodiment described above, the thickness of the cavity C in the primary driving step is greater than the target molding thickness; however, by setting the upper and lower punch positions so that the thickness of the cavity in the primary driving step becomes the target molding thickness, the secondary driving step need only be executed when warping and the like of the device has caused the thickness of the cavity to deviate from the target molding thickness, thereby simplifying the control of the device and shortening the manufacturing time. In this compacting method, when the thickness of the cavity is smaller than the target molding thickness in the primary driving step, the compacted green compact is smaller than the desired thickness, but this is effective in cases where, for instance, sufficient precision is achieved when the thicknesses of the green compacts are less than a fixed value.

[0073] As described above, according to this invention, since pressure molding is performed while measuring the gap between upper and lower punches until the material powder reaches the target molding thickness, even when variations arise in the filling amount of the material powder, or when the frame stretches or warps, green compacts of the target molding thickness can be stably manufactured.

[0074] Moreover, by filling the material powder evenly in the entire cavity, and pressing with a fixed gap between the upper and lower punches, green compacts having an overall even thickness and density can be stably manufactured.

1. A powder compacting method for performing a punch driving step comprising:

filling material powder in a cavity; and

pressure molding the material powder filled in the cavity by using an upper punch and a lower punch,

said punch driving step comprising a primary driving step of driving either one of the punches until the thickness of the cavity formed between the upper and lower punches becomes slightly greater than a target molding thickness, and a secondary driving step of measuring a gap between the upper and lower punches and driving either one of the punches while controlling it until the measured value reaches the target molding thickness.

2. A powder compacting method for performing a punch driving step comprising:

filling material powder in a cavity; and

pressure molding the material powder filled in the cavity by using an upper punch and a lower punch,

said punch driving step comprising a primary driving step of driving either one of the punches so that the upper and lower punches become closer to each other, and a secondary driving step of, when the gap between said upper and lower punches is greater than the target molding thickness due to said primary driving step, driving either one of the punches while controlling the gap between the upper and lower punches until it reaches the target molding thickness.

3. The powder compacting method according to claim 1, wherein, in said punch driving step, either one of said upper and lower punches is driven in said primary driving step and said secondary driving step, and the other punch is fixed in said primary driving step and said secondary driving step.

4. The powder compacting method according to claim 2, wherein, in said punch driving step, either one of said upper and lower punches is driven in said primary driving step and said secondary driving step, and the other punch is fixed in said primary driving step and said secondary driving step.

5. The powder compacting method according to claim 1, wherein, in said punch driving step, either one of said upper and lower punches is fixed in said primary driving step, this punch being driven in said secondary driving step, and the other punch is driven in secondary driving step, this punch being fixed in said secondary driving step.

6. The powder compacting method according to claim 2, wherein, in said punch driving step, either one of said upper and lower punches is fixed in said primary driving step, this punch being driven in said secondary driving step, and the other punch is driven in secondary driving step, this punch being fixed in said secondary driving step.

7. The powder compacting method according to claim 1, wherein said filling step is comprised of a forwarding step of moving forward over the cavity a shoe box, which can slide on a top face of said die and has an open bottom face, and a removal step of removing said shoe box from over said cavity; midway during said removal step, said lower punch is raised relatively with respect to said die, part of the material powder that is filled in said cavity is pushed onto said die, part of the material powder that was pushed onto said die is wiped away by said shoe box that is being removed, and, when said removal step has ended, the

relative position of said lower punch with respect to said die is returned to its position prior to the removal step.

8. A powder compacting device for pressure molding of material powder, filled in a cavity, between an upper punch and a lower punch, comprising:

a primary drive device for driving one of said upper and lower punches upwards and downwards;

a secondary drive device for minutely adjusting the top to bottom position of one of said upper and lower punches;

a measuring unit for determining the gap between the upper and lower punches; and

a control section for feeding back a measurement result of the measuring unit, and controlling said secondary drive device so that the measurement result reaches a target value.

9. The powder compacting device according to claim 8, wherein one of said upper and lower punches is driven by said primary drive device and said secondary drive device.

10. The powder compacting device according to claim 8, wherein one of said upper and lower punches is driven by said primary drive device and the other is driven by said secondary drive device.

11. The powder compacting device according to claim 8, wherein said upper punch is driven by said secondary drive device.

12. The powder compacting device according to claim 8, wherein said lower punch is driven by said secondary drive device.

* * * * *