

C. A. CUMMINGS.
BALANCED VALVE.
APPLICATION FILED DEC. 28, 1909.

1,000,588.

Patented Aug. 15, 1911.

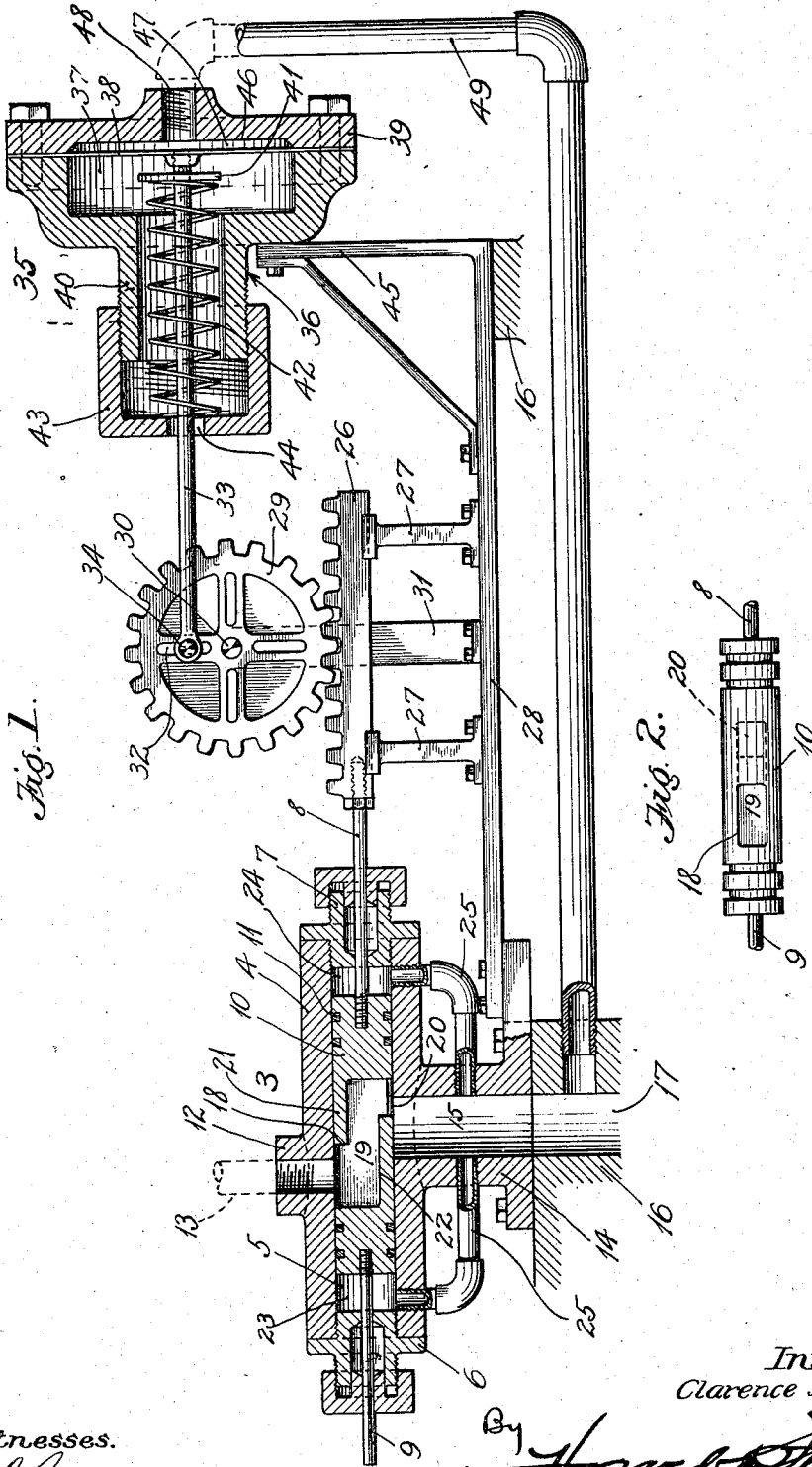

Fig. 1.

Fig. 2.

Witnesses.
F. A. Sommer
E. R. Pollard

Inventor:
Clarence A. Cummings.

By *Harold H. H. H.*
Attorneys.

UNITED STATES PATENT OFFICE.

CLARENCE A. CUMMINGS, OF FRESNO, CALIFORNIA.

BALANCED VALVE.

1,000,588.

Specification of Letters Patent. Patented Aug. 15, 1911.

Application filed December 28, 1909. Serial No. 535,243.

To all whom it may concern:

Be it known that I, CLARENCE A. CUMMINGS, a citizen of the United States, residing at Fresno, in the county of Fresno and State of California, have invented new and useful Improvements in Balanced Valves, of which the following is a specification.

This invention relates to valves and particularly to regulating valves.

The object of the invention is to produce a valve of this class which is adapted to be controlled by variations of pressure of a liquid or gas and which is constructed in such a way that, although subjected on one side to a high pressure and on the other side to a comparatively low pressure, the valve will be balanced so that the force necessary to adjust the degree of opening of the valve will be relatively small, that is, such a force as could be exerted by a gas or liquid under a low pressure.

The invention consists in the construction and combination of parts to be more fully described hereinafter and particularly set forth in the claims.

In the annexed drawing which fully illustrates my invention, Figure 1 is a longitudinal vertical section through a valve constructed according to my invention and through the pressure regulator which is used in connection therewith, certain parts being broken away and partly shown in elevation. Fig. 2 is a plan of the slide or piston which forms the valve gate, the packing rings being removed.

Referring more particularly to the drawing, 3 represents the balanced valve which is in the form of a cut off or slide valve having an elongated body 4 provided with a longitudinal bore 5, said bore being closed by removable heads 6 provided with suitable stuffing boxes 7. Through one of the stuffing boxes 7 a valve stem 8 extends, and at the opposite end a tail stem or tail rod 9 is provided which is of the same diameter as the stem 8. In the bore 5 a slide or piston 10 is mounted which is of cylindrical form fitting closely in the bore as indicated. Near its ends this piston is provided with packing rings 11 of any suitable form as shown.

On its upper side the valve body 4 is provided with an inlet hub or boss 12 at which an inlet pipe 13 indicated in dotted lines is attached, and this inlet pipe is supposed to carry a gas or liquid under a relatively high pressure. The under side of the body 4 is

formed into an outlet hub 14 having a vertical bore or discharge opening 15 and this hub 14 is mounted upon a suitable base 16 having a duct 17 communicating with the discharge or outlet 15, and also communicating with the part of the apparatus under low pressure.

On its upper side the piston or slide 10 is provided with an inlet port 18 which extends downwardly into the interior of the slide and connects with a short longitudinally extending passage 19 in the interior of the slide. One end of this passage 19 connects with the port 18 as shown, and the other end connects with an outlet port 20 formed on the under side of the gate. In this way the ports 18 and 20 are offset from each other. These ports and the passage 19 connecting them are of the same width measured transversely of the slide, as indicated in Fig. 2.

As shown in Fig. 1, the length of the port 18 is substantially equal to the width or diameter of the outlet 15, and the port 20 is of less length measured longitudinally of the valve. It will be seen that the passage 19 and the ports 18 and 20 form an offset duct passing through the piston, that is, the ports 18 and 20 are not opposite to each other. Furthermore, on account of the difference in length of the ports 18 and 20, the passage 19 presents a surface 21 on its upper side which is of less area than the surface 22 on the under side of the passage. This excess of area is very slight, however, and its purpose will appear more fully hereinafter.

It should be observed that the piston 10 is of considerably less length than the bore 5 in which it slides so that the chambers 23 and 24 are formed between the ends of the piston and the heads 6. These chambers 23 and 24 are in communication with the outlet 15 through pipe connections 25 arranged as shown.

The valve stem 8 is adjustably connected at its end with the end of a rack 26 which is mounted to slide longitudinally on suitable guide posts 27 attached to a base plate or bracket 28. This rack 26 has teeth on its upper side which mesh with a gear wheel 29 which is mounted on a horizontal pivot pin 30 secured in the upper end of a post 31, which post is also mounted on the base plate 28. The gear wheel 29 is provided with radial slots 32 in one of which a regulator

stem 33 is adjustably attached by means of a suitable pin 34. This regulator stem 33 extends into the interior of a pressure regulator 35. This pressure regulator 35 has a body 36 enlarged at its outer end to form a chamber 37, said chamber being provided with a diaphragm 38 held in position by a suitable cover 39. It is also provided with a tubular neck 40 of reduced diameter which extends toward the gear wheel, and through this neck 40 the stem 33 extends inwardly as suggested, the inner end of the stem being attached to the diaphragm 38 near its center. Near the diaphragm 38 a collar 41 is fixed on the stem 33 and a coiled spring 42 is arranged so that its inner end thrusts against this collar so as to resist the movement of the diaphragm in the direction of the gear wheel. The outer end of this spring thrusts against a cap 43 which screws on the end of the tubular neck 40 and having an enlarged opening 44 through which the stem 33 passes as shown. The regulator body 36 is suitably mounted on an upward extension or arm 45 forming part of the base plate 28. As shown, the inner face of the cover 39 is formed with a slight depression or dish 46 so that a part of the chamber 37 is cut off to form a pressure chamber 47. The cover is provided with a central opening 48 which communicates with this pressure chamber 47 and at this opening a pipe connection 49 is attached, the other end of which connects with an opening 50 which is in communication with the duct 17, that is, it is in communication with the low pressure side of the system in which the valve is employed.

The mode of operation of the valve and pressure regulator will now be described.

In this connection it should be understood that the pressure regulator is controlled automatically by the pressure existing in the low pressure system, that is, I control the degree of opening of the valve piston 10 by variations of this low pressure. It will be seen that upon a rise of pressure in the low pressure system the diaphragm 38 will be moved toward the left. This will rotate the gear wheel 29 in a left hand direction moving the rack 26 toward the right. This will move the piston 10 toward the right and advance the "cut-off" edge 51 of the piston toward the right at the outlet 15. In this way the degree of opening at this point will be reduced. This reduction of the effective port opening at the port 20 will reduce the pressure existing on the low pressure side of the valve. In this way the pressure regulator and the valve cooperate so as to maintain the pressure on the low pressure side of the system at a substantially constant point.

Attention is called to the enlarged port 18 and this feature is of great importance in securing the balanced effect in the valve 3,

for the reason that it substantially prevents any application of the high pressure gas or liquid to the upper side face of the piston 10. On account of the fact that the surface 22 is slightly in excess of the surface 21 in area, it follows that the gas or liquid in the passage 19 exerts a slight downward pressure on the piston 10. In other words, with respect to its interior, the valve is slightly unbalanced so that there is a slight excess of downwardly exerted force on its upper side. This excess of pressure or downward force is balanced however, by the pressure exerted on the low pressure side, which pressure is applied to the under side of the valve at the point where the "cut-off" edge 51 overhangs the outlet 15. In this way I produce a substantially balanced piston or gate which will require a very small force to slide it. It will be understood for these reasons that this apparatus will be very sensitive to slight changes in pressure on the low pressure side of the system.

The ends of the piston 10 are of course balanced by the equality in pressure existing in the chambers 23 and 24, and in this connection it should be noted that the areas exposed to pressure through the pipe connections 25 are equal.

Having described my invention, what I claim as new and desire to secure by Letters Patent, is:—

1. A balanced valve comprising a body, a gate sliding within said body and provided with a duct passing transversely therethrough, said duct having a passage extending longitudinally of said gate and having an enlarged opening on the side of said gate disposed toward the high pressure admission point, said gate having a single opening of reduced size with respect to said enlarged opening disposed on the side of said gate toward the low pressure side of said gate, said passage having an area on its upper side exposed to the pressure within said duct tending to press said gate toward the high pressure side of said valve, and also having an area exposed to the high pressure and tending to force said gate toward the low pressure side, said gate being arranged to cut off on the low pressure side, said areas being arranged so that the pressure on said gate from the low pressure side substantially balances the pressure on the high pressure side.

2. A balanced valve having a valve body with a high pressure connection on the upper side thereof and a low pressure connection on the under side thereof, said high pressure connection being of reduced diameter, said low pressure connection being of enlarged diameter, a gate sliding in said body having a duct passing transversely therethrough, said duct comprising a passage extending longitudinally, having a port on the upper side communicating with said

high pressure connection and having a port on the lower side communicating with said low pressure connection.

3. A balanced valve having a body with a high pressure connection of reduced dimension on the upper side thereof, a low pressure connection of enlarged dimension on the under side thereof, a gate mounted to slide in said body having a longitudinal passage presenting substantially horizontal surfaces of unequal areas, and having a port on its upper side constantly maintaining communication between said passage and said high pressure connection, said duct having a cut off port on its under side communicating with said low pressure connection.

4. A balanced valve comprising a body, a gate sliding within said body provided with a duct passing transversely there-through and having a passage extending longitudinally therein, said body having a high pressure connection on one side of said gate and having a low pressure connection on the opposite side of said gate, said passage having an area on its upper side exposed to the pressure within said duct tending to press said gate toward the high pressure side of said valve and also having an area exposed to the high pressure and tending to force said gate toward the low pressure side, said piston being arranged to cut off on the low pressure side, said areas being arranged so that the pressure on said gate from the low pressure side substantially balances said gate; said valve body having chambers in the ends thereof beyond said gate and means for maintaining equality of pressure in said chambers.

5. A balanced valve comprising a body, a gate sliding within said body provided with a duct passing transversely there-through and having a passage extending longitudinally therein, said body having a high pressure connection on one side of said gate and having a low pressure connection on the opposite side of said gate, said passage having an area on its upper side ex-

posed to the pressure within said duct tending to press said gate toward the high pressure side of said valve and also having an area exposed to the high pressure and tending to force said gate toward the low pressure side, said piston being arranged to cut off on the low pressure side, said areas being arranged so that the pressure on said gate from the low pressure side substantially balances said gate, said valve body having chambers in the end thereof beyond said gate, and means for maintaining said chambers in communication with the same source of pressure to equalize the pressure on the ends of said gate.

6. A balanced valve having a body with a high pressure connection on one side thereof and a low pressure connection on the opposite side thereof, a gate mounted to slide in said body, said gate having a passage therethrough opening communication between said high pressure connection and said low pressure connection and affording means for balancing the side pressures on said gate; and a pressure regulator connected with said low pressure connection and having means for moving said gate.

7. A balanced valve having a body with a high pressure connection on one side thereof and a low pressure connection on the other side thereof, a gate sliding in said body and having a duct opening communication between said high pressure connection and said low pressure connection affording means for balancing the side pressures on said gate, means for balancing the longitudinal pressures at the ends of said gate, and automatic means for moving said gate controlled by the pressure existing in said low pressure connection.

In witness that I claim the foregoing I have hereunto subscribed my name this 20th day of December, 1909.

CLARENCE A. CUMMINGS.

Witnesses:

F. D. AMMEN,

E. A. STRAUSE.

Copies of this patent may be obtained for five cents each, by addressing the "Commissioner of Patents, Washington, D. C."

BEST AVAILABLE COPY