

(19) World Intellectual Property Organization  
International Bureau



(43) International Publication Date  
20 October 2005 (20.10.2005)

PCT

(10) International Publication Number  
WO 2005/097004 A2

(51) International Patent Classification<sup>7</sup>: A61F 2/44,  
2/46, A61B 17/88, 17/92

(21) International Application Number:  
PCT/US2005/010255

(22) International Filing Date: 28 March 2005 (28.03.2005)

(25) Filing Language: English

(26) Publication Language: English

(30) Priority Data:  
60/556,860 26 March 2004 (26.03.2004) US

(71) Applicant (for all designated States except US): SYN-  
THES (U.S.A.) [US/US]; 1690 Russell Road, P.O. Box  
1766, Paoli, PA 19301-1222 (US).

(72) Inventors; and

(75) Inventors/Applicants (for US only): RANDALL, Bran-  
don, L. [US/US]; 1804 Skiles Blvd., West Chester, PA  
19382 (US). GOODWIN, Roger, D. [US/US]; 138 Carol  
Drive, Clarks Summit, PA 18411 (US). MESSERLI,  
Dominique [CH/US]; 200 La Vida Via, Downingtown, PA

19335 (US). MYER, Jacqueline [US/US]; 1121 Dogwood  
Ct., Pottstown, PA 19465 (US). DELURIO, Robert, J.  
[US/US]; 2458 Weir Rd., Aston, PA 19014 (US). BOYER,  
Michael, L., II [US/US]; 333 Lancaster Ave., Apt. 1000,  
Malvern, PA 19355 (US). ANGELUCCI, Christopher,  
M. [US/US]; 809 Summit Ave., Schwenkesville, PA 19473  
(US).

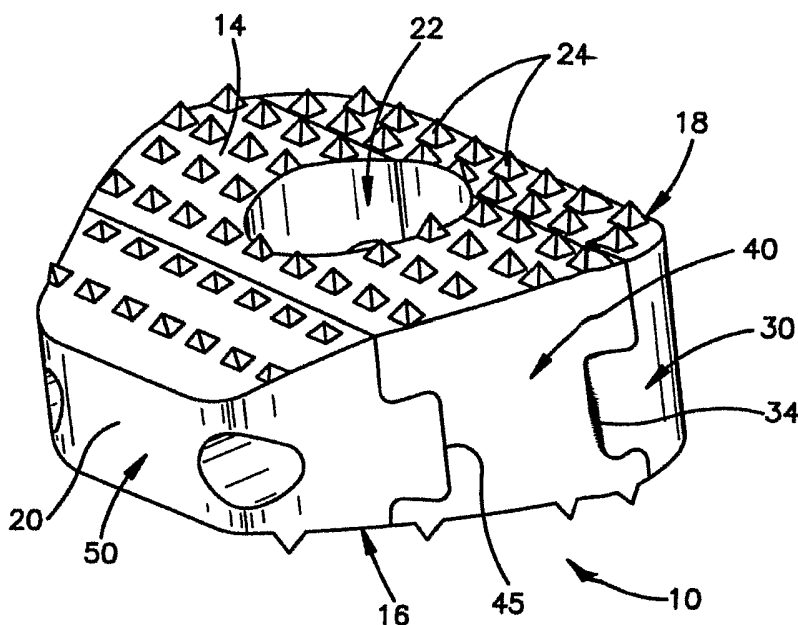
(74) Agents: POISSANT, Brian, M. et al.; Jones Day, 222 East  
41st Street, New York, NY 10017-6702 (US).

(81) Designated States (unless otherwise indicated, for every  
kind of national protection available): AE, AG, AL, AM,  
AT, AU, AZ, BA, BB, BG, BR, BW, BY, BZ, CA, CH, CN,  
CO, CR, CU, CZ, DE, DK, DM, DZ, EC, EE, EG, ES, FI,  
GB, GD, GE, GH, GM, HR, HU, ID, IL, IN, IS, JP, KE,  
KG, KP, KR, KZ, LC, LK, LR, LS, LT, LU, LV, MA, MD,  
MG, MK, MN, MW, MX, MZ, NA, NI, NO, NZ, OM, PG,  
PH, PL, PT, RO, RU, SC, SD, SE, SG, SK, SL, SM, SY, TJ,  
TM, TN, TR, TT, TZ, UA, UG, US, UZ, VC, VN, YU, ZA,  
ZM, ZW.

(84) Designated States (unless otherwise indicated, for every  
kind of regional protection available): ARIPO (BW, GH,  
GM, KE, LS, MW, MZ, NA, SD, SL, SZ, TZ, UG, ZM,  
ZW), Eurasian (AM, AZ, BY, KG, KZ, MD, RU, TJ, TM),

[Continued on next page]

(54) Title: ALLOGRAFT IMPLANT



(57) Abstract: An allogenic implant for use in intervertebral fusion is formed from one or more two pieces. The pieces are made from bone, and are joined together to form an implant having sufficient strength and stability to maintain a desired distance between first and second vertebrae in a spinal fusion procedure. The implant pieces may be formed of cortical bone and connected by dovetail joints, and at least one cortical bone pin may be provided to lock the pieces together and to add strength to the implant. Teeth are formed on the vertebra engaging surfaces of the implant prevent short-term slippage of the implant.

WO 2005/097004 A2



European (AT, BE, BG, CH, CY, CZ, DE, DK, EE, ES, FI, FR, GB, GR, HU, IE, IS, IT, LT, LU, MC, NL, PL, PT, RO, SE, SI, SK, TR), OAPI (BF, BJ, CF, CG, CI, CM, GA, GN, GQ, GW, ML, MR, NE, SN, TD, TG).

*For two-letter codes and other abbreviations, refer to the "Guidance Notes on Codes and Abbreviations" appearing at the beginning of each regular issue of the PCT Gazette.*

**Published:**

— *without international search report and to be republished upon receipt of that report*

## ALLOGRAFT IMPLANT

### FIELD OF THE INVENTION

[001] The present invention is directed to an allogenic implant and, more particularly, to an allogenic intervertebral implant for the fusion of vertebrae.

### BACKGROUND OF THE INVENTION

[002] A number of medical conditions, such as compression of spinal cord nerve roots, degenerative disc disease, and trauma can cause severe back pain. Intervertebral fusion is a surgical method of alleviating back pain. In intervertebral fusion, two adjacent vertebral bodies are fused together by removing the affected intervertebral disc and inserting an implant that would allow for bone to grow between the two vertebral bodies to bridge the gap left by the removed disc.

[003] A number of different implants and implant materials have been used for fusion with varying success. Current implants for intervertebral fusion include metallic cages, radiolucent implants and allografts. Metallic cages suffer from the disadvantage of requiring drilling and tapping of the vertebral endplates for insertion. In addition, the incidence of subsidence in long term use is not known. Due to MRI incompatibility of metallic cages, determining fusion is problematic. Radiolucent implants require the inclusion of metal or radiopaque markers to allow the surgeon to determine the adequacy of fusion, but like metallic cages radiolucent implants are not as readily integrated into the patient's bone structure as are allografts.

[004] Allografts are sections of bone usually taken from long bones, such as the radius, ulna, fibula, humerus, tibia, or femur of a donor. A portion of the bone is taken and processed using known techniques to preserve the allograft until implantation and reduce the risk of an adverse immunological response when implanted. For example, U.S. Pat. No. 4,678,470 discloses a method for processing a bone grafting material which uses glutaraldehyde tanning to produce a non-antigenic, biocompatible material. Allografts have mechanical properties which are similar to the mechanical properties of vertebrae even after processing. This prevents stress shielding that occurs with metallic implants. They also promote the formation of bone, i.e., are osteoconductive, and are also MRI compatible so that fusion of the adjacent vertebrae can be more accurately ascertained. Although the osteoconductive nature of the allograft provides a biological interlocking between the allograft and the vertebrae for long term mechanical strength, initial and short term

mechanical strength of the interface between the allograft and the vertebrae needs to be addressed to minimize the possibility of the allograft being expelled after implantation.

**[005]** Most allografts are simply sections of bone which, although cut to the approximate height of the disc being replaced, have not been sized and/or machined on the exterior surface to have a uniform shape. As a result, the fusion of the vertebral bodies does not occur in optimal anatomic position or in a consistent manner along the surface of the vertebral endplates. While a surgeon may perform some minimal intraoperative shaping and sizing to customize the allograft to the patient's spinal anatomy, significant and precise shaping and sizing of the allograft during the procedure is not possible due to the nature of the allograft. Even if extensive shaping and sizing were possible, a surgeon's ability to manually shape and size the allograft to the desired dimensions is limited.

**[006]** With respect to the overall structure of a given bone, the mechanical properties vary throughout the bone. For example, a long bone (leg bone) such as the femur has both cortical bone and cancellous bone. Cortical bone, the compact and dense bone that surrounds the marrow cavity, is generally solid and thus carries the majority of the load in long bones. Cancellous bone, the spongy inner bone, is generally porous and ductile, and when compared to cortical bone is only about one-third to one-quarter as dense, one-tenth to one-twentieth as stiff, but five times as ductile. While cancellous bone has a tensile strength of about 10-20 MPa and a density of about 0.7, cortical bone has a tensile strength of about 100-200 MPa and a density of about 2. Additionally, the strain to failure of cancellous bone is about 5-7%, while cortical bone can only withstand 1-3% strain before failure. It should also be noted that these mechanical characteristics may degrade as a result of numerous factors such as any chemical treatment applied to the bone material, and the manner of storage after harvesting but prior to implantation (*i.e.* drying of bones).

**[007]** The superior structural properties of cortical bone (as compared to cancellous bone) make it desirable for use as a spinal fusion implant. Thus, cortical bone implants may be obtained by taking a cross-section of the diaphysis of any one of the aforementioned long bones. The resulting cross-sectional implant will have a solid ring of cortical bone and a hollow center portion (the medullary canal of the long bone) that is suitable for packing with osteogenic materials, such as blood or allograft. Only a certain portion of each long bone, however, has the dimensions suitable for making cortical ring implants. The substantial remaining cortical portions of each long bone (*e.g.* the end portions such as the metaphysis) thus may remain unused for making structural cortical allograft implants.

[008] Thus, there is a need to provide an allograft implant having similar dimensional and structural properties to traditional cortical ring allografts, but which is made up of multiple pieces of cortical bone that might otherwise remain unused for such structural allograft implants.

#### **SUMMARY OF THE INVENTION**

[009] The present invention relates to an allogenic intervertebral implant for use when surgical fusion of vertebral bodies is indicated. The implant preferably comprises a wedge or plug conforming in size and shape with the end plates of adjacent vertebrae and has a plurality of teeth positioned on the top and bottom surfaces for interlocking with the adjacent vertebrae. The teeth preferably have a pyramid shape or a saw-tooth shape.

[010] The implant preferably is comprised of a monolithic portion of cortical bone. In one embodiment, however, the implant may be comprised of two or more pieces of cortical bone. The two or more sections may be attached by a dovetail joint. One or more pins may also be used to prevent the sections from sliding out of connection with each other. The pins may be made of allogenic bone.

[011] The implant preferably has teeth on the surfaces of the implant that will engage the vertebral end plates. The teeth are configured to bite into the bone of the vertebral end plates to resist expulsion of the implant subsequent to insertion.

[012] The implant may take on various profiles and exterior geometries, depending upon the area of the spine that is to be treated. The implant may further be shaped with various thicknesses, to maintain the proper distance between the vertebrae being treated.

[013] The present invention relates to an allogenic intervertebral implant for use when surgical fusion of vertebral bodies is indicated. The implant may generally comprise a wedge or plug of bone conforming in size and shape with the end plates of adjacent vertebrae and may have a plurality of teeth positioned on the top and bottom surfaces for interlocking with the adjacent vertebrae. The teeth may have a pyramidal or saw-tooth shape.

[014] The implant may be made of a monolithic portion of cortical bone. Alternatively the implant may be comprised of two or more pieces of cortical bone. The two or more pieces of bone may be attached by a dovetail or other joint. One or more fasteners or pins may be used to prevent the sections from sliding out of connection with each other. The pins may be made of allogenic cortical bone.

[015] The implant may have teeth on the surfaces of the implant that will engage the vertebral end plates. The teeth may be configured to bite into the bone of the vertebral end plates to resist expulsion of the implant subsequent to insertion.

[016] The implant may take on various profiles and exterior geometries, depending upon the area of the spine that is to be treated. The implant may further be shaped with various thicknesses, to maintain the proper distance between the vertebrae being treated.

[017] A multipiece implant may be provided having superior and inferior surfaces for engaging the end plates of adjacent vertebra of a patient's spinal column. The implant may comprise at least first and second cortical bone segments, where each segment has a locking surface configured to engage the locking surface of the other segment. Each segment further may have a pair of vertebra-engaging surfaces and at least one fastener-engaging surface. At least one fastener may be provided for engaging the bone segments. The locking surfaces of the first and second bone segments may comprise corresponding male and female surfaces, and the fastener may be configured to contact the fastener-engaging surfaces of the first and second bone segments to lock the segments together to form a multipiece implant having mechanical properties substantially similar to those of an implant formed of a single piece of cortical bone.

[018] The locking surfaces of the first and second bone segments may comprise a dovetail joint. Alternatively, the locking surfaces may comprise a tongue and groove joint. Further, the vertebra-engaging surfaces of each cortical bone segment comprise a plurality of teeth, and these teeth may be arranged in a two dimensional array, where at least some of the teeth have a pyramidal shape.

[019] The superior surface of the implant may have a substantially convex curvature, and both the superior and inferior surfaces may each comprise a plurality of teeth. The teeth may also be arranged in a two dimensional array, and the teeth may have a pyramidal shape.

[020] The superior surface and the inferior surface may have a convex curvature in the medial-lateral plane.

[021] The fastener may comprise a pin made of cortical bone, and the locking element engaging surface of each cortical bone segment may comprise at least one bore configured to receive the cortical bone pin. The implant may also have an anterior-posterior axis, and the at least one bore may be aligned substantially parallel to the axis. Alternatively, the at least one bore is aligned substantially non-parallel to the axis.

[022] The implant may have superior and inferior engaging surfaces configured to engage adjacent vertebral end plates, and the implant further have an opening in communication with the superior and inferior engaging surfaces and configured to receive osteogenic material.

[023] The implant may further comprise an anterior-posterior axis, a second cortical locking pin, and a second fastener engaging surface comprising a second bore

configured to receive the second cortical locking pin. At least one of the first and second bores may be aligned substantially non-parallel to the anterior-posterior axis. The first and second bores may be arranged so that they do not intersect the opening and the bores may also be oriented to allow at least one dimension of the opening to be maximized.

**[024]** The fastener may comprise a cortical bone pin and the fastener engaging surface of each bone segment may comprise a bore configured to receive the cortical bone pin, the fastener engaging surface of at least one bone segment further may comprise an abutting surface configured to engage an end surface of the cortical bone pin. The first and second bone segments of the implant may comprise an anterior bone segment and a center bone segment, respectively. The implant may further comprise a posterior bone segment engaged to the center bone segment via a dovetail joint, wherein the abutting surface is arranged on the posterior bone segment so that when the implant is placed between vertebral end plates of a patient, the pin is thereafter prevented from migrating in the direction the posterior direction. Alternatively, the abutting surface may be located in the anterior bone segment so that when the implant is placed between vertebral end plates of a patient, the pin is thereafter prevented from migrating in the anterior direction.

**[025]** A method of manufacturing an intervertebral implant is also provided. The implant may have superior and inferior surfaces, as well as an exterior surface. The method may comprise the steps of: forming at least first, second and third implant pieces from cortical bone; connecting the first and second pieces using a joint having a male element disposed on one of the first and second pieces and a corresponding female element disposed on the other of the first and second pieces; connecting the second and third pieces using a joint having a male element disposed on one of the second and third pieces and a corresponding female element disposed on the other of the second and third pieces; locking the first, second and third pieces together using a cortical bone pin disposed within bores formed through at least a portion of each piece to form an implant configured to be inserted between adjacent vertebra of a patient's spinal column; and forming superior and inferior vertebra engaging surfaces on the implant, wherein the engaging surfaces each comprise a plurality of teeth.

**[026]** The step of forming a first piece may further comprise forming the male portion of a first dovetail joint, the step of forming a third piece may further comprise forming the male portion of a second dovetail joint, and the step of forming a second piece may further comprise forming opposing female portions of the first and second dovetail joints. The step of forming the first piece may further comprise marking an indicia on a face of the first piece, the indicia providing a visual indicia of implant orientation.

[027] The indicia may comprise an arrow and the teeth may comprise pyramidal teeth. Furthermore, the superior vertebra engaging surface may have a convex profile. The superior and inferior vertebra engaging surfaces may also be oriented substantially non-parallel with respect to each other.

[028] Subsequent to the step of locking the first, second and third pieces together, the implant may be machine so that the implant perimeter that substantially conforms to the outer perimeter of a patient's vertebral end plate. The implant may further having a medial-lateral centerline, and the cortical bone pin may be disposed within a bore that is oriented substantially non-parallel to the medial-lateral centerline.

[029] The kit may also include an impactor for precisely positioning and impacting the implant between the vertebrae. The impactor may comprise a proximal hand gripping end and a distal implant-engaging end. The implant-engaging end may have an implant engaging face that is sized and dimensioned to engage the anterior face of the implant.

[030] An intervertebral implant kit may be provided comprising: at least one implant configured for insertion between the end plates of adjacent vertebrae in the spinal column of a patient. The implant may comprising at least first and second cortical bone segments and may also have first and second vertebra engaging surfaces and a perimeter. At least one implant insertion tool may also be provided for engaging the implant and inserting the implant between the adjacent vertebrae, the tool having at least one implant engaging end configured to grip the implant. The perimeter of the implant may have an anterior segment configured to substantially conform to the anterior shape of the adjacent vertebral end plates when the implant is installed between the adjacent vertebrae, and the implant engaging end of the tool may further be configured to engage the implant along a substantial portion of the anterior segment.

[031] The implant further may further comprise a third cortical bone segment and at least a first fastener configured to lock the first, second and third bone segments together. The fastener may comprise a cortical bone pin. Further, at least one vertebra engaging surface of the implant may have a convex shape.

[032] The implant may further comprise at least one opening in communication with at least one of the first and second vertebra engaging surfaces, and the opening may be configured to receive osteogenic, osteoinductive, or osteoconductive material. The implant may further comprising an anterior-posterior centerline, the fastener having an axis oriented at an acute angle with respect to the centerline. The intervertebral may also comprise a second fastener configured to lock the first, second and third bone segments together, the second fastener having an axis oriented at an acute angle with respect to the



anterior-posterior centerline. Alternatively, the axes of the first and second fasteners may be oriented non-parallel with respect to each other.

[033] The implant further comprising at least one through hole in communication with at least one of the first and second vertebra engaging surfaces and configured to receive bone growth enhancing materials, the implant further comprising a second fastener configured to lock the first, second and third bone segments together, wherein the first and second fasteners each have an axis, the axes oriented to maximize the size of the opening.

[034] The vertebra engaging surfaces of the implant may comprising a plurality of protrusions configured to engage the respective vertebral end plate. The protrusions may comprise pyramidal shaped teeth.

[035] The anterior segment of the implant may have first and second recesses, and the implant engaging end of the tool may have first and second protrusions for engaging the first and second recesses, wherein the recesses and protrusions are configured to allow the tool to firmly grip the implant.

[036] The tool may further have first and second arms, the arms each having a proximal gripping end and distal implant-engaging end, wherein the first protrusion is disposed on the distal end of the first arm and the second protrusion is disposed on the distal end of the second arm. The tool may further comprise a pivot mechanism connecting the first and second arms at a location between the proximal and distal ends of the arms.

[037] The first and second protrusions of the tool may engage the first and second recesses when the distal end of the tool contacts the anterior segment of the implant and the gripping ends of the first and second arms are moved toward each other.

[038] The implant and the implant-engaging end of the tool may each comprise a medial-lateral dimension, and the medial lateral dimension of the tool may be equal to or less than the medial lateral dimension of the implant.

#### **BRIEF DESCRIPTION OF THE DRAWINGS**

[039] **Fig. 1** is a perspective view of an exemplary embodiment of the implant according to the present invention;

[040] **Fig. 2** is a top view of the implant of **Fig. 1**;

[041] **Fig. 3** is a side view of the implant of **Fig. 1**;

[042] **Fig. 4** is an end view of the implant of **Fig. 1**;

[043] **Fig. 5** is a partial side view of the implant of **Fig. 1**;

- [044] **Fig. 6A and 6B** are side views of second and third exemplary embodiments of the implant according to the present invention;
- [045] **Fig. 7** is an exploded view of a fourth exemplary embodiment of the implant according to the present invention;
- [046] **Fig. 8** is a top view of the implant of **Fig. 7**;
- [047] **Fig. 9** is a side view of the implant of **Fig. 7**;
- [048] **Fig. 10** is an end view of the implant of **Fig. 7**;
- [049] **Fig. 11** is a top view of a fifth exemplary embodiment of the implant according to the present invention;
- [050] **Fig. 12** is a top view of a sixth exemplary embodiment of the implant according to the present invention;
- [051] **Fig. 13** is a top view of the implant of **Fig. 12**;
- [052] **Figs. 14A and 14B** are side and partial side views, respectively, of an implant insertion tool for use with the implant according to the present invention;
- [053] **Fig. 15** is a perspective view of a seventh exemplary embodiment of the implant and an implant insertion tool according to the present invention;
- [054] **Figs. 16A through 16E** are perspective views of several designs for mechanical fasteners for use with the implants of **Figs. 1-15**;
- [055] **Fig. 17** is a top view of an eighth exemplary embodiment of the implant of the present invention;
- [056] **Fig. 18** is a side detail view of a pyramidal tooth for use in any one of the previous embodiments.
- [057] **Fig. 19** is a perspective view of another exemplary embodiment of the implant according to the present invention.
- [058] **Fig. 20** is a top view of a further exemplary embodiment of the implant according to the present invention.
- [059] **Fig. 21** is an end view of yet another exemplary embodiment of the implant according to the present invention.
- [060] **Figs. 22a-22b** are top and side views, respectively, of an impactor for use with the implant according to the present invention.

#### DETAILED DESCRIPTION OF THE INVENTION

[061] **Figs. 1-4** show a first embodiment of an intervertebral cortical allograft implant **10** according to the present invention. Implant **10** preferably is shaped to conform in size and shape with at least a portion of the end plates of the vertebrae between which

implant **10** is to be inserted. The outer periphery of implant **10** may be sized and shaped to match the outer periphery of the end plates of the vertebrae between which the implant **10** is to be used. Alternatively the outer periphery of the implant **10** may be sized and shaped to match only a portion of the outer periphery of the end plates of the vertebrae, or it may have an outer periphery that may not match the peripheral shape of the end plates of the vertebrae at any location.

[062] Implant **10** generally comprises a superior surface **14**, an inferior surface **16**, an anterior face **18**, a posterior face **20** and an opening **22**. The implant **10** may be substantially symmetrical about a central axis "A-A" which connects and bisects the anterior and posterior faces **18**, **20**. The superior and inferior surfaces **14**, **16** further may comprise teeth **24** disposed on at least a portion of each surface. Teeth **24** may be configured to engage the associated vertebral end plates to hold the implant securely in position when it is placed therebetween. In the illustrated embodiment, teeth **24** are discrete pyramidal projections having walls that form angles of approximately 60 degrees with respect to the plane of the respective superior or inferior surface **14**, **16**. It should be noted that although pyramidal shaped teeth **24** are illustrated, any appropriate tooth configuration may be provided, including discrete conically shaped teeth, continuous saw-tooth shaped patterns, or any other appropriate surface roughening or texturing known in the art.

[063] Implant **10** may be formed by the connection of up to three discrete cortical bone segments **30**, **40** and **50**. In the illustrated embodiment, the anterior **30**, center **40**, and posterior **50** bone segments are connected via dovetail joints **34**, **45** (Fig. 3). These dovetail joints **34**, **45** are oriented substantially perpendicular to axis "A-A," in order to provide maximum resistance to a force applied along axis "A-A," tending to separate the segments. In the illustrated embodiment, female joint portion is provided on the center bone segment **40**, with male joint portions provided on the anterior and posterior bone segments **30**, **50**. This orientation may be reversed, or may be provided in any appropriate combination on any of the bone segments. Likewise, although the dovetail joints are illustrated as being oriented substantially perpendicular to axis "A-A," these joints may be oriented at other appropriate angles with respect to the central axis.

[064] The dovetail joints may also be oriented on other surfaces of the bone segments. For example, the female and male joint portions may be provided on the superior and anterior surfaces of the implant. Fig. 19 shows dovetail joints **36**, **47** on the superior surface **14** of the implant **10**. In this embodiment, the dovetail joints **36**, **47** are oriented in the same plane as opening **22**. In the illustrated embodiment, female joint

portion is provided on the center bone segment **40**, and male joint portions are provided on the anterior and posterior bone segments **30, 50**.

[065] The implant **10** may further be provided with mechanical connectors **60, 70**, which in the illustrated embodiment are cylindrical pins composed of cortical bone. These pins **60, 70** may be disposed in correspondingly-shaped bores **80, 90** formed through the cortical bone segments **30, 40** and **50**. These pins may be oriented substantially parallel to the axis "A-A," and substantially perpendicular to the dovetail joints **34, 45** to provide maximum resistance to a force applied perpendicular to axis "A-A" tending to separate the segments. Cortical pins **60, 70** may also provide the implant with increased strength in bending as compared to a multipiece implant without pins.

[066] It is noted that although the implant **10** is shown as having two pins, an implant having a single pin may alternatively be provided (see Fig. 11). Such an implant may have a simplified construction, while still providing the implant with a desired strength in bending. In a further alternative embodiment, the cortical pin or pins **60, 70** may be oriented substantially non-parallel to the implant central axis "A-A," such that the pins may be oriented at angles up to and including about 15 degrees with respect to axis "A-A" (see Figs. 7-9). In yet a further embodiment, an implant **10** may be provided with a pin or pins **60, 70** oriented substantially perpendicular to both axis "A-A" and to the superior and inferior surfaces **14, 16** of the implant **10** (see Figs. 12-13).

[067] Moreover, with any of these embodiments, the pins **60, 70** and their respective bores **80, 90** may be formed so that the pins and holes go through the entire length (or height) of the implant, or they may be formed so that the pins and holes go through only a portion thereof. In one embodiment, the bores **80, 90** may go through the entire length of the anterior and central bone segments **30, 40**, but may only go through a portion of the posterior bone segment **50** as shown in Fig. 20. Thus, the pins **60, 70** may abut an internal end surface of the posterior bone segment **50**. In this illustrated embodiment, the cortical pins **60** and **70** may be machined to be cone shaped at the ends **61, 71** of the pins **60, 70** that abut the internal end surface of the posterior bone segment **50**. Such an arrangement may have the advantage of guaranteeing that the cortical pins **60, 70** can not work themselves loose from the bone segments after insertion in the patient and move in the posterior direction toward the spinal canal. Such an internal abutting configuration could likewise be implemented for the anterior bone portion to prevent a loosened pin from moving anteriorly toward the patient's esophagus.

[068] The cortical pins **60, 70** may take on any appropriate configuration, and may be secured within the implant in a variety of ways. For example, the fasteners **60, 70** may be secured within corresponding bores **80, 90** by a press fit. Alternatively, the pin or pins

may have threads along at least a portion of their length which may mate with a correspondingly threaded bore or bores in the implant. The pin or pins may have any appropriate external geometric cross-sectional shape, such as circular (**Fig. 16A**), X-shaped, ovular, square (**Fig. 16B**), rectangular, etc., and may be accepted in bores having similar or different cross-sectional shapes. Likewise, the pins may assume a "split pin" arrangement (**Fig. 16C**), or the pin may have a series of alternating longitudinal grooves and raised radial portions (**Fig. 16D**). The pins may also have one or more circumferentially-disposed rib elements (**Fig. 16E**). Other pin designs may also be used as appropriate. The pin or pins may also be secured using an appropriate biocompatible adhesive. Any combination of such securing configurations may also be used. Such arrangements may keep the pins from separating from the implant either before, during or after implantation within a patient.

[069] As will be apparent to one of ordinary skill in the art, each pin arrangement may provide individual advantages both in terms of manufacturability and implant integrity. These advantages will be described in more detail later in relation to the description of each individual embodiment.

[070] Thus, when fully assembled, the pins **60, 70** and joints **34, 45** may provide a multipiece cortical bone implant **10** that may function substantially the same as an implant made of a single, monolithic piece of cortical bone.

[071] As shown in **Figs. 2 and 3**, the bone segments **30, 40** and **50** may be sized and dimensioned to result in an overall implant length "**L**" in the range of from about 10 millimeters (mm) to about 15 mm. In one embodiment, length "**L**" is about 12.5 mm. Likewise, the bone segments may be sized and dimensioned to result in an overall implant width "**W**" at its widest point that is within the range of from about 12 mm to about 18 mm. In one embodiment, width "**W**" may be about 15 mm. Opening **22** may have a diameter "**D**" of about 5.5 mm. An implant having such dimensions may be configured to fit within the endplates of the vertebra of the cervical spine. However, it will be understood that the implant **10** may have different dimensions than the ones described herein without departing from the spirit and scope of the invention. Furthermore, opening **22** may assume any of a variety of geometric shapes, including circular (as in **Figs. 1-3**), square, rectangular, ovular, etc., or the opening **22** may have a non-geometric shape. Alternatively, opening **22** may consist of a plurality of discrete openings. In the embodiment shown in **Fig. 17**, the opening **22** is shaped to substantially match the external shape of the implant, thus providing an implant having a relatively constant wall thickness "**t**." The wall thickness "**t**" may be chosen from a value within the range of from about 2 mm to about 5 mm; and in one embodiment the thickness "**t**" may be about 3 mm. This arrangement may provide an

implant having as large an opening as possible, to maximize the amount of osteogenic material that may be packed therein.

[072] Implant **10** may a plurality of teeth **24** formed over at least a portion of its superior and inferior surfaces **14**, **16** that may provide a mechanical interlock between implant **10** and the end plates of the vertebrae to be treated. As shown in **Figs. 1, 3** and **4** teeth **24** may be formed in rows disposed over the entire superior and inferior surfaces **14**, **16** and the teeth **24** may be pyramid shaped. As illustrated in **Fig. 18**, the pyramidal teeth may have a tooth angle " $\phi$ " formed from the tip to the base of approximately 60 degrees. The teeth may also have a tooth height "TH" chosen from a value in the range of from about 0.3 mm to about 0.7 mm. In one embodiment the tooth height "TH" is about 0.5 mm. As previously noted, however, these teeth **24** may take any appropriate configuration known in the art, both in profile and the pattern in which they are disposed over the superior and inferior implant surfaces of the implant. Because these teeth **24** are formed from cortical bone, they have sufficient strength and hardness to impale themselves into the vertebrae surfaces and provide an enhanced interlock with the adjacent vertebrae, thus preventing short-term slippage of implant **10** until implant **10** is fused with the vertebrae by the growth of new bone.

[073] In the embodiment shown in **Figs. 1** to **4**, superior surface **14** is convex and inferior surface **16** is flat. The convex superior surface **14** may have a radius of curvature in the range of from about 8 mm to about 25 mm. In one embodiment (**Fig. 3**), convex superior surface **14** may have a radius of curvature "SRC" of about 14 mm. The inferior surface **16** of this embodiment may form an angle  $\alpha$  with respect to the central axis "A-A." Angle  $\alpha$  may be within the range of from about 2 degrees to about 5 degrees. In one embodiment,  $\alpha$  is about 3.5 degrees. Thus, the implant may have a greater height "HA" adjacent the anterior face **18** compared to the height "HP" adjacent the posterior face **20**. Height "HA" may be within the range of from about 4 mm to about 11 mm, while height "HP" may be within the range of from about 2.4 mm to about 9.4 mm. Such a configuration provides a good fit with the natural contours of the normal cranial and caudal surfaces of the cervical vertebrae, while also restoring the desired natural lordosis between adjacent vertebrae.

[074] In an alternative embodiment, both the superior and inferior surfaces may have a convex curvature in order to more closely conform the implant to the anatomy of the patient's vertebral end plates. Thus, in one embodiment the curvature of the superior surface may be disposed in the anterior-posterior plane, while the curvature of the inferior surface **16** may be disposed in the medial lateral plane. It will be appreciated, however,

that other surface configurations may be provided to allow close conformity of the implant to the end plates.

[075] In an alternative embodiment shown in **Fig 6A**, both the superior and inferior surfaces **140, 160**, are flat, and each surface forms an angle  $\beta$  with respect to the central axis "A-A," thus providing an implant **100** having a wedge shape, with a height "HA" adjacent the anterior face **126** that is greater than the height "HP" adjacent the posterior face **128**. Height "HA" may be within the range of from about 4 mm to about 11 mm, while height "HP" may be within the range of from about 2.5 mm to about 9.5 mm. Angle  $\beta$  may be within the range of from about 2 degrees to about 5 degrees. In one embodiment,  $\beta$  is about 3.5 degrees. In yet another embodiment, shown in **Fig. 6B**, both the superior and inferior surfaces **240, 260** are flat, and each is substantially parallel to the central axis "A-A," thus providing a substantially flat implant **200** in which the height "HA" and "HP" adjacent the anterior and posterior faces **218, 216**, respectively. Heights "HA" and "HP" may be within the range of from about 4 mm to about 11 mm.

[076] The superior surface **14** and the inferior surface **16** may have the same or different curvatures in the same or different planes. For example, one surface may be convex and the other surface may be flat. Alternatively, in the embodiment shown in **Fig. 21**, the superior surface **14** and the inferior surface **16** have a convex curvature in the medial lateral plane as shown by lines X-X.

[077] In all of the illustrated embodiments, typified in **Figs. 2 and 3**, the implant **10** is formed so that anterior face **18** is curved, while posterior face **20** is flat. Anterior face **18** may have a radius of curvature "R" within the range of about 15 mm to about 25 mm. In one embodiment this radius is about 20 mm.

[078] As illustrated in more detail in **Fig. 5A**, the male dovetail portion "MP" may have an anterior-posterior length "dl" of about 1.2 mm, a maximum superior-inferior height "dh" of about 5 mm, and a tail angle  $\gamma$  of about 25 degrees with respect to the implant central axis. The female dovetail portion may have similar dimensions. These dimensions may be adjusted as appropriate, and the clearances between the male and female portions may be selected to provide an interference fit if desired. The described dimensions will provide an interlocking of adjacent bone segments **30, 40, 50** to withstand expected forces of the spinal column to which the implant will be subjected after implantation.

[079] An alternative embodiment of a dovetail joint for use in joining adjacent bone portions is illustrated in **Fig. 5B**, in which female portion "FP" has upper and lower engaging faces "EF" that are angled with respect to the vertical. Specifically, the engaging faces "EF" form an angle " $\tau$ ," of about 2 degrees with respect to the respective male engaging faces "MEF" shown in **Fig. 5A**. Thus, when the male and female dovetail

portions "MP," "FP" are fit together, the female portion may deflect slightly near the engaging faces "EF", thus providing a tight fit between the opposing bone portions. This feature may also provide the advantage of eliminating the gap that may form between the opposing bone pieces once the implant **10** has been freeze-dried, since the bone portions may shrink slightly during that process. The interference fit thus provided may lock the male and female portions "MP," "FP" together with sufficient force that cortical locking pins may not be needed to lock the implant together. A sufficiently tight interference fit may thus provide a simplified implant.

**[080]** As previously noted, opening **22** may be shaped and configured to be as large as possible to maximize the amount of osteogenic, osteoconductive, or osteoinductive material that may be packed therein. Such material may speed fusion of the implant **10** with the opposing vertebra. A non-limiting list of such materials includes blood, bone chips, demineralized bone matrix, calcium phosphate bone cements, or any other osteogenic, osteoconductive or osteoinductive material known in the art.

**[081]** As shown in **Fig. 4**, the anterior surface **18** of the implant **10** may have a vertical line **26** as an indicia of both the medial-lateral centerline of the implant and the anterior end of the implant. Since the implant may be rather small, such an indicia may aid the surgeon in fitting the implant to the installation tool. Alternatively, the implant **10** may be provided with a multidimensional indicia **27** which may additionally identify the superior and inferior surfaces of the implant. In the illustrated embodiment, an arrow is provided as identifying the medial-lateral centerline of the anterior face **18** of the implant **10** and which also identifies the proper superior-inferior orientation of the implant. Alternatively, other distinguishing indicia of implant orientation may be provided, such as an alphanumeric identifier or a word (e.g. "anterior"). Such markings **26, 27** may be applied using any appropriate biocompatible ink, or they may be etched into the surface of the implant.

**[082]** With the above described geometries, implant **10** may ideally be used between cervical vertebrae. However, it can be readily seen by those skilled in the art that implant **10** may take on many different geometries to optimize its use between vertebrae in different areas of the spine.

**[083]** **Figs. 7-10** illustrate an alternative embodiment of a multipiece cortical implant **300** comprising anterior, center, and posterior cortical bone segments **330, 340A, B** and **350**. As shown in **Fig. 7**, implant **300** has the same general shape as the previously described embodiments, including the rounded anterior face **318**, flat posterior face **320**, and opening **322**. Moreover, superior and inferior surfaces **314, 316** have a plurality of vertebra-engaging teeth **324** disposed thereon.



[084] The embodiment of **Figs. 7-10**, however, has cortical pins **360, 370** that are oriented at an acute angle  $\theta$  with respect to the implant central axis "A-A." Angle  $\theta$  may be within the range of from about 12 degrees to about 18 degrees, and in one embodiment,  $\theta$  is about 15 degrees. Thus, the distance between the bores **380, 390** may be greater at the anterior face **318** than at the posterior face **320**. This arrangement allows for a larger opening **322** to be provided as compared to the previous embodiments, because the bores **380, 390** and pins **360, 370** of this embodiment are located farther apart where they pass through the center bone segment **340**. Providing a larger opening **322** allows the surgeon to pack the implant with more osteoinductive or osteoconductive material than with the previous embodiments, thus increasing the likelihood that the implant will be successfully integrated into the adjacent vertebral elements. In one embodiment, opening **322** has a diameter "cd" of about 7.1 mm. It is noted that the center bone segment **340A, B** is composed of two pieces due to the size of the opening. Such a two-piece center bone segment **340A, B** does not detract from the structural integrity of the implant because each segment is captured by one cortical pin **360, 370**.

[085] The angled pins **360, 370** of this embodiment may also provide an additional locking feature not present with the parallel pins of the previous embodiments. Specifically, the angled pins may resist a force applied to the implant along axis "A-A" that would tend to separate the bone segments **330, 340, 350**. With the previous embodiments, this was a function provided by the dovetail joints between the bone segments. Since the pins perform the anterior-posterior retention function in the present embodiment, the dove-tail joints **34, 35** between bone segments may be replaced with simpler tongue and groove joints **334, 345**. Such tongue and groove joints are easier to manufacture and to fit together during implant assembly.

[086] The implant **300** of this embodiment may be provided in any of the previously described superior and inferior surface profiles, such as convex, lordotic (parallel wedge) and parallel. The convex profile is specifically designed to fit the anatomy of the end plates of the vertebra. The lordotic profile is specifically designed to maintain the anatomical alignment of the spinal column. It will be appreciated that all other geometric configurations of the previous embodiments, including applicable pin and bore configurations, may be applied to the implant **300** of the present embodiment.

[087] **Fig. 11** illustrates an alternative embodiment of the invention in which implant **400** is provided with a single cortical pin **460** oriented substantially parallel to the implant central axis "A-A." The pin of this embodiment is located on one side of the opening **422**, and, in combination with a pair of dovetail joints **434, 445** serves to lock the anterior, center, and posterior bone segments **430, 440, 450** together in a manner identical to that of

the embodiment of **Fig. 1**. The implant **400** of this embodiment provides an advantage over previous embodiments in that it is simpler to manufacture and requires fewer total pieces. Furthermore, although the absence of a second cortical pin may render this implant slightly less strong in bending as compared to the dual pin embodiments of **Figs. 1-10**, the bending strength of this implant **400** may still be sufficient to withstand the loads experienced in the spinal column in normal use. As with the embodiment of **Figs. 7-10**, implant **400** may be provided with convex, lordotic and parallel engaging surface configurations. Likewise, all other geometric configurations of the previous embodiments, including applicable pin and bore configurations and pyramidal teeth configurations, may be implemented in implant **400**.

**[088]** **Figs. 12 and 13** illustrates yet another embodiment of an implant **500** having a pair of vertically oriented pins **560, 570** for locking together adjacent bone segments **530, 540, 550**. In this embodiment, pins **560, 570** are oriented substantially perpendicular both to the implant central axis "A-A" and to the superior and inferior surfaces **514, 516**. This embodiment has the advantage that it may be easier to machine as compared to the horizontal pin embodiments because the bores may be located farther from the implant sides than in the horizontal pin embodiments, and thus the implant may be less likely to exhibit cracking when during the machining operation. This embodiment also has the advantage that the cortical pins **560, 570** may function to bear at least a portion of the vertebral end-forces applied to the implant due to their general alignment with the superior-inferior axis upon insertion. Furthermore, since the pins are vertically oriented, there is less chance that they might become loosened in the patient and migrate beyond the implant.

**[089]** **Figs. 14A and 14B** are side and partial side views, respectively, of an implant insertion tool **1000** for use with any of the previously described implants. As illustrated, the tool **1000** has a proximal hand gripping end **1100** and a distal implant-gripping end **1200**. The hand gripping end **1100** comprises a pair of lever arms **1110, 1120**, while the implant-gripping end **1200** comprises a pair of implant-gripping jaws **1210, 1220**. The arms and jaws are connected by an intermediate pivot element **1300** to provide a scissors-like actuation in which movement of the lever arms **1110, 1120** toward each other moves the gripping jaws **1210, 1220** together.

**[090]** The tool **1000** may be configured to engage an anterior portion of the implant **10** (i.e. the portion associated with anterior face **18**). Thus, implant-gripping jaws **1210, 1220** may comprise respective implant engaging surfaces **1212, 1222**. These engaging surfaces may each further comprise an implant gripping section **1214, 1224** and an implant impaction section **1216, 1226**. The implant gripping sections **1214, 1224** are configured to wrap around the anterior portion of the implant to lock the implant **10** within the jaws of the

tool **1000**. When gripping an implant **10**, the implant impaction section **1216, 1226** is located adjacent the anterior face **18** of the implant and is configured to transmit an impaction force applied via the tool directly to the anterior face **18** of the implant **10**, thus facilitating insertion of the implant between the targeted intervertebral space. As a result of this arrangement, the gripping tool conforms to the natural outer contour of the implant. Thus, the implant **10** need not incorporate additional features such as notches, grooves, or engagement holes to allow it to be gripped by the tool. Rather, a simpler overall implant design is provided, and it is also one in which the strength of the implant is not compromised by the inclusion of such notches, grooves or engagement holes.

[091] The proximal end of the tool **1000** may be an impaction surface **1130**, a portion of which is disposed at the proximal-most point of each lever arm **1110, 1120**. This impaction surface **1130** may be generally flat and suitable for being impacted using a mallet or other appropriate impacting tool to aid in the insertion of the implant **10** in the targeted intervertebral space. A biasing assembly **1400** comprising a pair of leaf springs **1410, 1420** may also be provided between the lever arms **1110, 1120** to bias the arms and jaws **1210, 1220** open to make gripping and releasing the implant **10** easier.

[092] The tool **1000** may further be provided with a grip-locking assembly **1500** comprising threaded nut **1510** and rod **1520** combination to lock the arms (and the jaws) in the gripping position. Thus, in the illustrated embodiment a first end **1522** of the rod **1520** may be pinned to an inner surface **1112** of the first lever arm **1110** and the second end **1524** may extend through a bore **1122** in the second lever arm **1120** such that at least an intermediate portion **1526** of the rod extends beyond the outer surface **1124** of the second arm **1120**. Threaded nut **1510** may be adjustably located along this intermediate portion **1526** of the rod to prevent movement of the lever arms **1110, 1120** away from each other beyond a point determined by the position of the nut **1510** on the rod **1520**. Typically, the surgeon may initially adjust the nut to lie adjacent the rod second end so that maximum separation of the lever arms **1110, 1120** and gripping jaws **1210, 1220** is permitted. Once the surgeon grips the implant **10**, the nut **1510** may then be adjusted along the rod **1520** to a position abutting the outer surface **1124** of the second lever arm **1120**, thus preventing the arms **110, 1120** and jaws **1210, 1220** from opening and thereby locking the tool **1000** and the implant **10** together. In one embodiment, the nut **1510** is a speed-nut, which may allow quick actuation and locking of the relative position of the lever arms **1110, 1120**.

[093] In an alternative embodiment, a threaded hole (not shown) may be formed in the implant through the anterior surface **18** to receive a threaded end of an implant inserter to implant the implant between the vertebrae.

[094] A further alternative embodiment of the invention is illustrated in **Fig. 15**, in which implant **600** is configured so that an installation tool **2000** may engage the implant along only the implant anterior face **618**, as opposed to the earlier embodiments in which the tool engages the implant by wrapping around a portion of the outer perimeter of the implant. The advantage to the present embodiment is that the tool presents a medial-lateral aspect no greater than the medial-lateral width of the implant at its widest portion. Thus, the size of the opening between the targeted vertebrae is minimized.

[095] Implant **600** thus has tool engaging recesses **610**, **620** formed at the outer edges of the anterior surface **618**. These recesses **610**, **620** are configured to receive correspondingly shaped tip portions **2002**, **2004** of engaging tool **2000**. Recesses **610** and **620** further define raised portions **612**, **622** which allow the tip portions **2002**, **2004** to positively axially engage the implant **600** to allow the tool **2000** to tightly engage the implant **600**. Tool arms **2110**, **2120** may each have an implant impaction surface **2216**, **2226** configured to conform to the anterior surface **618** of the implant **600**, thus allowing an impaction force applied via the tool **2000** to be evenly applied to the implant. Aside from the implant-engaging geometry, tool **2000** may be similar in all other details to tool **1000**, previously described in relation to **Figs. 14A** and **14B**.

[096] After the implant is placed between the vertebrae, an impactor may be used to precisely position and impact the implant between the vertebrae. **Figs. 22a** and **22b** show a top and side view, respectively, of an impactor **700** for use with any of the implants described herein. As illustrated, the impactor **700** may have a proximal hand gripping end **710** and a distal implant-engaging end **720**. The impactor **700** may be configured to engage an anterior portion or segment of the implant **10** (*i.e.*, the portion associated with the anterior face **18**). The implant-engaging end **720** of the impactor **700** may have an implant-engaging face **730** at the most distal end of the impactor **700**. When engaging an implant **10**, the implant-engaging face **730** may be located adjacent the anterior face **18** of the implant **10** and may be configured to transmit an impaction force applied via the impactor **700** directly to the anterior face **18** of the implant **10**, thus facilitating precise placement of the implant between the vertebrae. As a result of this arrangement, the impactor **700** may conform to the natural outer contour of the implant **10**. Preferably, the implant-engaging end **720** is sized and dimensioned to engage the anterior face **18** of the implant **10**. The implant-engaging face has a height **h** and a width **w** which may be equal to or less than the height **HA** and width **W**, respectively of the anterior surface of the implant **10**.

[097] The implant **10** need not incorporate additional features such as notches, grooves, or engagement holes to allow it to be engaged by the impactor. However, the

implant-engaging face **730** of the impacter **700** may have additional features such as notches or grooves to facilitate engagement with the implant **10** during impaction. Fig. **22a** shows grooves **740** in the implant-engaging-face **730**. The proximal end of the impacter may be an impaction surface (not shown) similar to that of the tool **1000**. In particular, the impaction surface of the impacter **700** may be generally flat and suitable for being impacted using a mallet or other appropriate impacting tool to aid in the precise positioning of the implant **10** in the intervertebral space.

**[098]** In order to restore the intervertebral space to the proper size after the affected disc has been removed, implant **10** has a height sized to match the height of the removed disc. Typically for cervical discectomies, this height is between about 5 mm to about 12 mm, but other heights may be used. Implant **10** may also be configured for corpectomies. In which case, it should be noted that implants **10** may be configured so that the height of the implant would be within the range of from about 10 to about 150 mm. Other heights may also be used. These larger sizes could be used in corpectomy, a surgical procedure in which an entire vertebral body is removed, including the disc material above and below it. Alternatively, the implant **10** may be configured for a hemi-corpectomy, which involves resecting only a portion of a vertebral body. Implants **10** would be inserted in the space created by the removed section of bone.

**[099]** While the embodiments described above comprise parts formed from three portions of cortical bone it will be appreciated that the invention may apply to one or more pieces of cortical bone formed together to create a unitary implant.

**[0100]** Further, while the invention has been described in relation to an implant formed entirely of cortical bone, it will be appreciated that any type of bone may be used, including cancellous and cortical bone, to form an implant having desired physical properties for use as a spinal fusion implant. Thus, an implant may be provided in which multiple pieces of cortical and or cancellous bone are combined in a single implant. Likewise, such an implant, or portions of such an implant, may be partially or fully demineralized, as desired to provide an implant with an increased propensity for integration with the adjacent vertebral bodies.

**[0101]** A method of manufacturing the inventive multipiece cortical bone implant is also provided. Implant **10** may be manufactured by first roughly shaping first, second and third portions **20, 30, 40** out of cortical allogenic bone. The portions may be oriented so that the Haversian canals of each bone portion are substantially aligned to be roughly perpendicular to the superior and inferior surfaces **14, 16** of the implant. Orienting the bone portions in this manner may provide an implant having maximum strength in the superior-inferior direction. It may also provide the benefit of readily allowing blood and/or

osteogenic materials to flow through the canals between the vertebral end plates, thus speeding fusion of the implant with the adjacent vertebrae.

[0102] Male and female portions of dovetail joints **34, 45** are then formed in the first, second and third portions **20, 30, 40** and respectively. The bone portions are then fit together by engaging the respective male and female parts of the respective press fit dovetail joints **34, 45**. Bores **80** and **90** for pins **60** and **70** are then formed in the first, second and third portions **30, 40** and **50**, and pins **60** and **70** are then inserted through the bores. If desired, adhesive may be used between portions **20, 30** and **40**, and/or between the portions and pins **60, 70**. In one embodiment, pins **70** and **80** are sized so that there is a slight interference between the exterior surface of the pins and their respective bores **80** and **90**. Pins **60, 70** are thus secured in bores **80, 90** by an interference fit. Alternatively, adhesive may be used to secure pin **50** into holes **28** and **38**. In a further alternative embodiment, the respective male and female parts of the respective dovetail joints may be configured to achieve an interference fit, to facilitate locking of the pieces together. This interference fit may provide sufficient locking integrity that the implant may be used without the need for cortical pins.

[0103] Opening **22** is then formed, and the outer perimeter of the implant **10** including anterior and posterior end surfaces **18, 20** is formed using the opening as the implant centroid. To further ensure that pins **60, 70** are retained within the bone portions **20, 30, 40** the ends of each pin may be peened or staked using a suitable tool, to deform/flare the end portion of each pin.

[0104] Superior and inferior surfaces **14, 16** are then shaped into the proper desired form, be it convex, lordotic or parallel. Finally, teeth **24** are formed into the superior and inferior surfaces **14, 16**. Tool-engaging surfaces such as a threaded bores or recesses are may also be formed at this point, if desired for a particular application.

[0105] In one embodiment, the shaping of the parts and sections of implant **10** is performed by computer-controlled milling. However, alternative methods of forming the various parts of implant **10** may also be used.

[0106] To facilitate osteointegration of the implant with the adjacent vertebral bodies, the implant may be partially demineralized either before or after assembly. Such demineralization may improve the osteoinductive properties of the cortical bone, thus speeding the fusion process. Since demineralized cortical bone is generally weaker than fully mineralized cortical bone, the implant may be only partially demineralized. Thus, providing a partially demineralized cortical implant may result in an implant having the desired increased osteoconductive properties without a significant decrease in implant strength. Such demineralization may be provided using any known method, including

controlled immersion in a hydrochloric acid (HCl) solution, or a loop flushing technique in which HCl solution is circulated over or through at least a portion of the implant.

**[0107]** Furthermore, while a partially demineralized implant is disclosed, it will be appreciated that any appropriate demineralization scheme may be provided to obtain a cortical implant having the desired structural and osteointegrative properties.

**[0108]** Once the implant has been fully formed, and, where appropriate, partially demineralized, the implant may be freeze dried and packaged for storage and shipping. Prior to implantation in a patient, the implant should be rehydrated by immersing the implant in a saline solution for a period of up to about 60 minutes. Rehydration may be performed using saline solution, blood, bone marrow, or any other appropriate fluid. Antibiotics or other pharmacologically active materials may also be applied to the implant at this time, and such materials may be added before, during or after the rehydration step.

**[0109]** While it is apparent that the illustrative embodiments of the invention herein disclosed fulfill the objectives stated above, it will be appreciated that numerous modifications and other embodiments may be devised by those skilled in the art. Therefore, it will be understood that the appended claims are intended to cover all such modifications and embodiments which come within the spirit and scope of the present invention.

**IN THE CLAIMS**

1. An multipiece implant having superior and inferior surfaces comprising:  
at least first and second cortical bone segments, each segment having a locking surface configured to engage the locking surface of the other segment, each segment further having a pair of vertebra-engaging surfaces and at least one fastener-engaging surface;  
at least one fastener;  
wherein the locking surfaces of the first and second bone segments comprise corresponding male and female surfaces, the fastener further configured to contact the fastener-engaging surfaces of the first and second bone segments to lock the segments together to form a multipiece implant having mechanical properties substantially similar to those of an implant formed of a single piece of cortical bone.
2. The multipiece implant of **claim 1**, wherein the locking surfaces of the first and second bone segments comprise a dovetail joint.
3. The multipiece implant of **claim 1**, wherein the vertebra-engaging surfaces of each cortical bone segment comprise a plurality of teeth.
4. The multipiece implant of **claim 2**, wherein the teeth are arranged in a two dimensional array, and at least some of the teeth have a pyramidal shape.
5. The multipiece implant of **claim 1**, wherein the multipiece implant has superior and inferior engaging surfaces configured to engage adjacent vertebral end plates and the superior surface has a substantially convex curvature.
6. The multipiece implant of **claim 5**, wherein the inferior surface has a substantially convex curvature.
7. The multipiece implant of **claim 6**, wherein the curvature of the superior surface lies in the anterior-posterior plane, and the curvature of the inferior surface lies in the medial-lateral plane.
8. The multipiece implant of **claim 5**, wherein the superior and inferior engaging surfaces each comprise a series of teeth.
9. The multipiece implant of **claim 8**, wherein the teeth are arranged in a two dimensional array, and the teeth have a pyramidal shape.



made of cortical bone.

11. The multipiece implant of **claim 10**, wherein the locking element engaging surface of each cortical bone segment comprises at least one bore configured to receive the cortical bone pin.

12. The multipiece implant of **claim 11**, the implant further comprising an anterior-posterior axis, the at least one bore being aligned substantially parallel to the axis.

13. The multipiece implant of **claim 12**, wherein the at least one bore is aligned substantially non-parallel to the axis.

14. The multipiece implant of **claim 11**, wherein the implant has superior and inferior engaging surfaces configured to engage adjacent vertebral end plates, the implant further comprising an opening in communication with the superior and inferior engaging surfaces and configured to receive osteogenic, osteoconductive or osteoinductive material.

15. The multipiece implant of **claim 14**, the implant further comprising an anterior-posterior axis, a second cortical locking pin, and a second fastener engaging surface comprising a second bore configured to receive the second cortical locking pin, wherein at least one of the first and second bores is aligned substantially non-parallel to the anterior-posterior axis.

16. The multipiece implant of **claim 15**, wherein the first and second bores do not intersect the opening and the bores are oriented to allow at least one dimension of the opening to be maximized

17. The multipiece implant of **claim 1**, wherein the fastener comprises a cortical bone pin and the fastener engaging surface of each bone segment comprises a bore configured to receive the cortical bone pin, the fastener engaging surface of at least one bone segment further comprising an abutting surface configured to engage an end surface of the cortical pin.

18. The multipiece implant of **claim 17**, the first and second bone segments comprising an anterior bone segment and a center bone segment, respectively the implant further comprising a posterior bone segment engaged to the center bone segment via a dovetail joint, wherein the abutting surface is located in the posterior bone segment so that when the implant is placed between vertebral end plates of a patient, the pin is thereafter prevented from migrating in the direction the posterior direction.

comprising an anterior bone segment and a center bone segment, the implant further comprising a posterior bone segment engaged to the center bone segment via a dovetail joint, wherein the abutting surface is located in the anterior bone segment so that when the implant is placed between vertebral end plates of a patient, the pin is thereafter prevented from migrating in the anterior direction.

20. A method of manufacturing an intervertebral implant having a superior surface, an inferior surface, and a perimeter, comprising the steps of:

forming at least first, second and third implant pieces from cortical bone;

connecting the first and second pieces using a joint having a male element disposed on one of the first and second pieces and a corresponding female element disposed on the other of the first and second pieces;

connecting the second and third pieces using a joint having a male element disposed on one of the second and third pieces and a corresponding female element disposed on the other of the second and third pieces;

locking the first, second and third pieces together using a cortical bone pin disposed within bores formed through at least a portion of each piece to form an implant configured to be inserted between adjacent vertebra of a patient's spinal column; and

forming superior and inferior vertebra engaging surfaces on the implant, wherein the engaging surfaces each comprise a plurality of teeth.

21. The method of **claim 20**, wherein the step of forming a first piece further comprises forming the male portion of a first dovetail joint, the step of forming a third piece comprises forming the male portion of a second dovetail joint, and the step of forming a second piece further comprises forming opposing female portions of the first and second dovetail joints.

22. The method of **claim 20**, wherein the step of forming the first piece further comprises marking an indicia on a face of the first piece, the indicia providing a visual indicia of implant orientation.

23. The method of **claim 22**, wherein the indicia comprises an arrow.

24. The method of **claim 21**, wherein the teeth comprise of pyramidal teeth.

25. The method of **claim 24**, wherein the superior vertebra engaging surface has a convex profile.

26. The method of **claim 25**, wherein the inferior surface has a substantially convex curvature.

the anterior-posterior plane, and the curvature of the inferior surface lies in the medial-lateral plane.

28. The method of **claim 20**, the superior and inferior vertebra engaging surfaces being oriented substantially non-parallel with respect to each other.

29. The method of **claim 20**, wherein, subsequent to the step of locking the first, second and third pieces together, the implant is machine d so that the implant perimeter that substantially conforms to the outer perimeter of a patient's vertebral end plate.

30. The method of **claim 29**, the implant further having a medial-lateral centerline, the cortical bone pin disposed within a bore that is oriented substantially non-parallel to the medial-lateral centerline.

31. An intervertebral implant kit, comprising:

at least one implant configured for insertion between the end plates of adjacent vertebrae in the spinal column of a patient, the implant comprising at least first and second cortical bone segments, the implant further having first and second vertebra engaging surfaces and a perimeter,

at least one implant insertion tool for engaging the implant and inserting the implant between the adjacent vertebrae, the tool having at least one implant engaging end configured to grip the implant,

wherein the perimeter of the implant has an anterior segment configured to substantially conform to the anterior shape of the adjacent vertebral end plates when the implant is installed between the adjacent vertebrae, and the implant engaging end of the tool is further configured to engage the implant along a substantial portion of the anterior segment.

32. The intervertebral implant kit of **claim 31**, the implant further comprising a third cortical bone segment and at least a first fastener configured to lock the first, second and third bone segments together.

33. The intervertebral implant kit of **claim 32**, wherein the fastener comprises a cortical bone pin.

34. The intervertebral implant kit of **claim 33**, wherein at least one vertebra engaging surface has a convex shape.

35. The intervertebral implant kit of **claim 34**, the implant further comprising at least one opening in communication with at least one of the first and second vertebra

osteoconductive material.

36. The intervertebral implant kit of **claim 32**, the implant further comprising an anterior-posterior centerline, the fastener having an axis oriented at an acute angle with respect to the centerline.

37. The intervertebral implant kit of **claim 31**, the implant further comprising a second fastener configured to lock the first, second and third bone segments together, the second fastener having an axis oriented at an acute angle with respect to the centerline.

38. The intervertebral implant kit of **claim 32**, wherein the axes of the first and second fasteners are oriented non-parallel with respect to each other.

39. The intervertebral implant kit of **claim 32**, the implant further comprising at least one opening in communication with at least one of the first and second vertebra engaging surfaces and configured to receive bone growth enhancing materials, the implant further comprising a second fastener configured to lock the first, second and third bone segments together, wherein the first and second fasteners each have an axis, the axes oriented to maximize the size of the opening.

40. The intervertebral implant kit of **claim 31**, the vertebra engaging surfaces further comprising a plurality of protrusions configured to engage the respective vertebral end plate.

41. The intervertebral implant kit of **claim 35**, wherein the protrusions comprise pyramidal shaped teeth.

42. The intervertebral implant kit of **claim 31**, the anterior segment of the implant having first and second recesses, and the implant engaging end of the tool further having first and second protrusions for engaging the first and second recesses, the recesses and protrusions configured to allow the tool to firmly grip the implant.

43. The intervertebral implant kit of **claim 42**, the tool further having first and second arms, the arms each having a proximal gripping end and distal implant-engaging end, wherein the first protrusion is disposed on the distal end of the first arm and the second protrusion is disposed on the distal end of the second arm.

44. The intervertebral implant kit of **claim 43**, the tool further comprising a pivot mechanism connecting the first and second arms at a location between the proximal and distal ends of the arms.

protrusions engage the first and second recesses when the distal end of the tool contacts the anterior segment of the implant and the gripping ends of the first and second arms are moved toward each other.

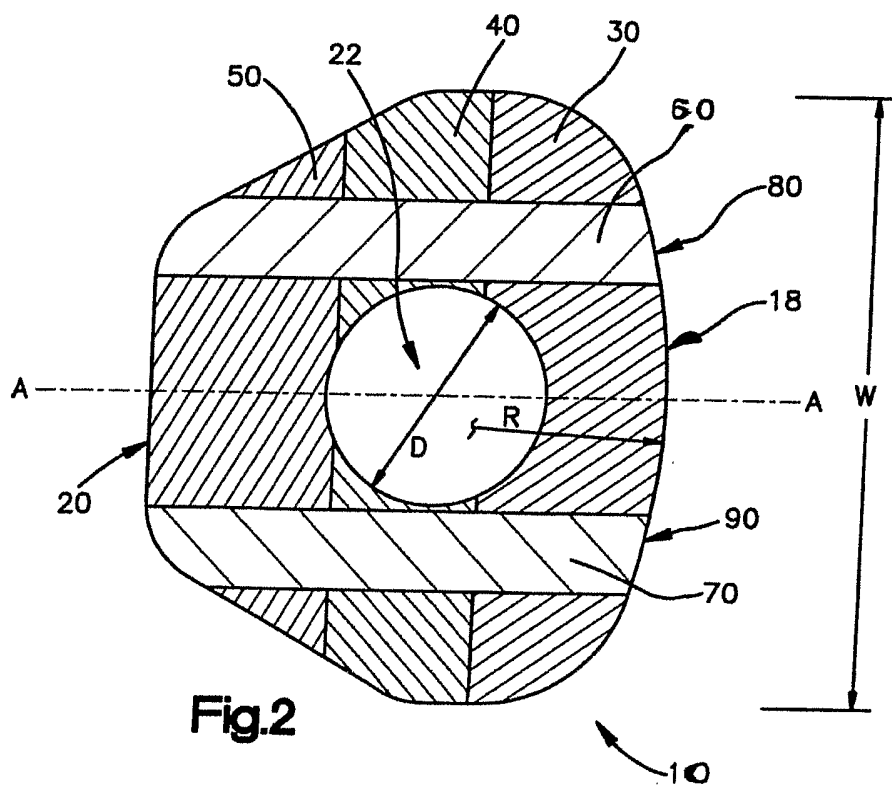
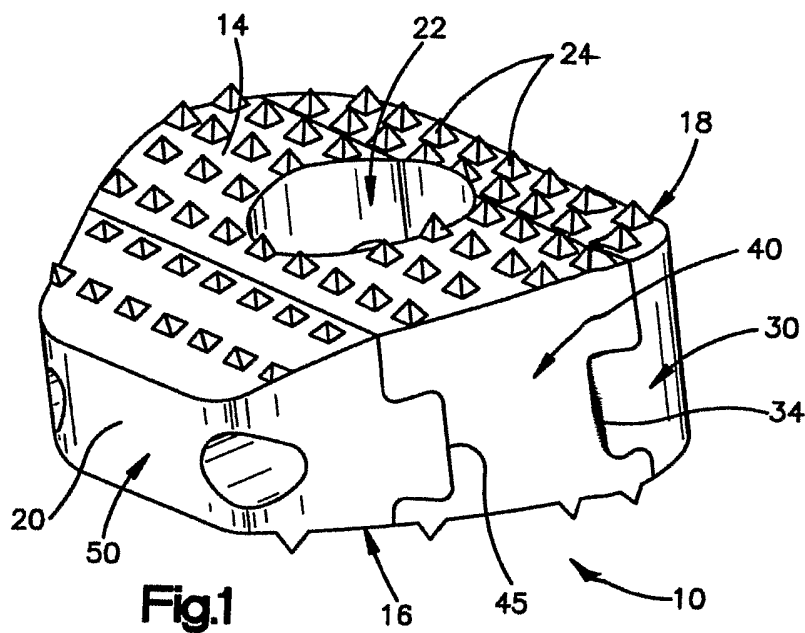
46. The intervertebral implant kit of **claim 45**, the implant further comprising a medial-lateral dimension, the implant engaging end of the tool further comprising a medial lateral dimension that is equal to or less than the medial lateral dimension of the implant.

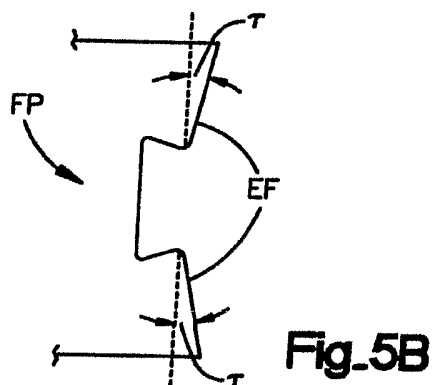
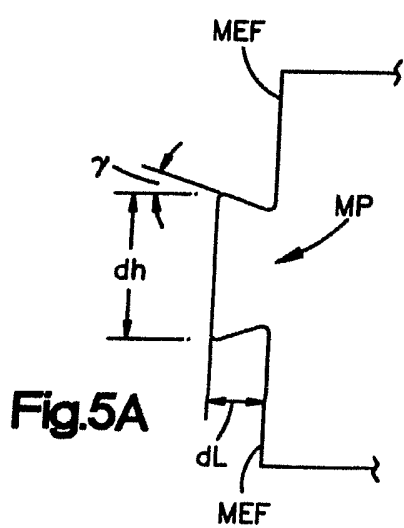
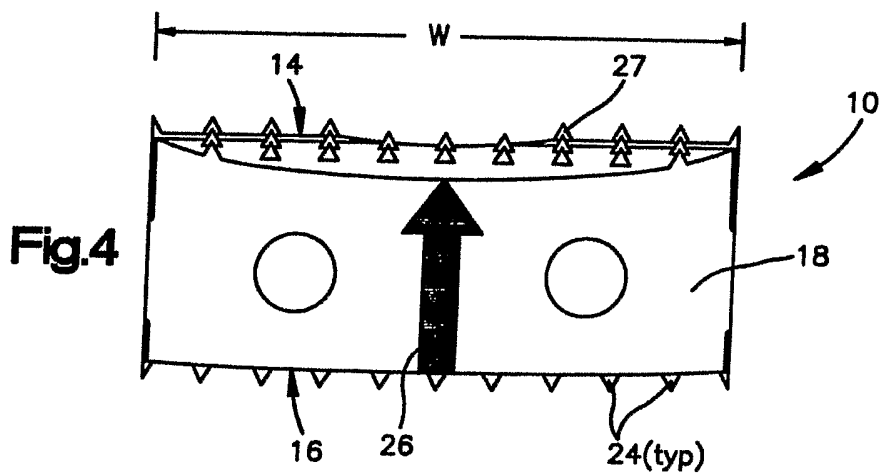
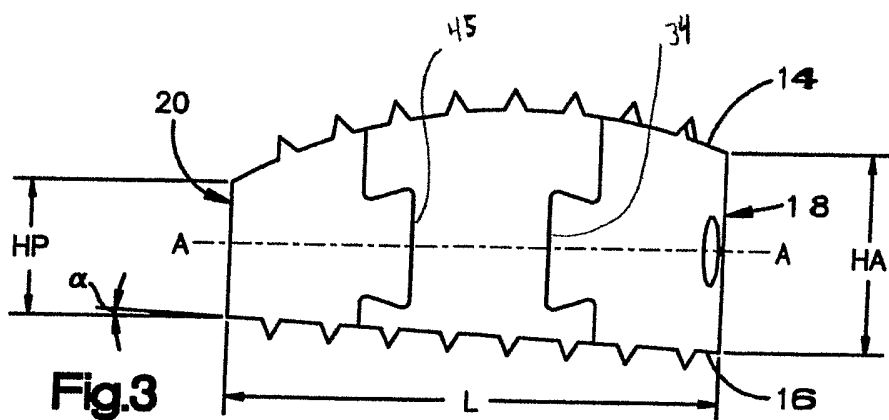
47. The intervertebral implant kit of **claim 45**, the implant further comprising a medial-lateral dimension, the implant engaging end of the tool further comprising a medial lateral dimension that is equal to or smaller than the medial lateral dimension of the implant.

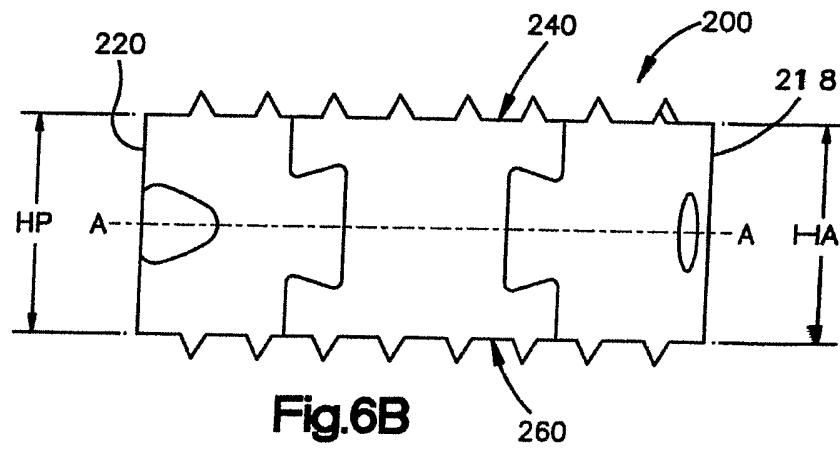
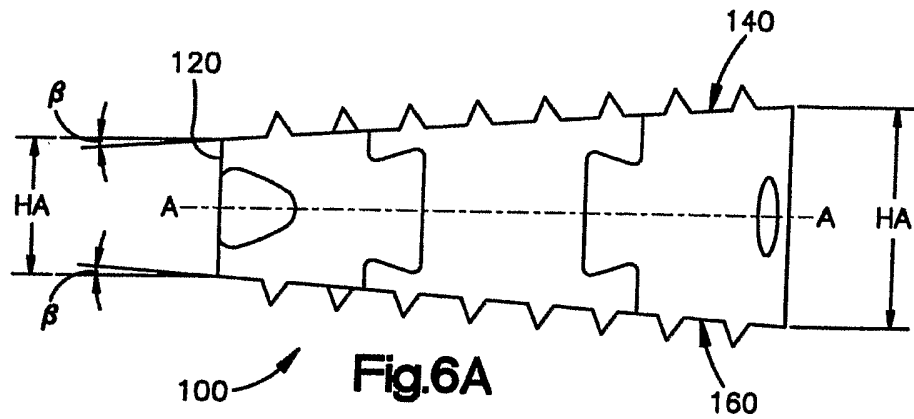
48. The intervertebral implant kit of **claim 31**, further comprising an impactor for positioning and impacting the implant between the vertebrae, wherein the impactor comprises a distal implant-engaging end comprising an implant-engaging face sized and dimensioned to engage the anterior segment of the implant.

49. The multipiece implant of **claim 6**, wherein the convex curvatures of the superior surface and the inferior surface lie in the medial-lateral plane.

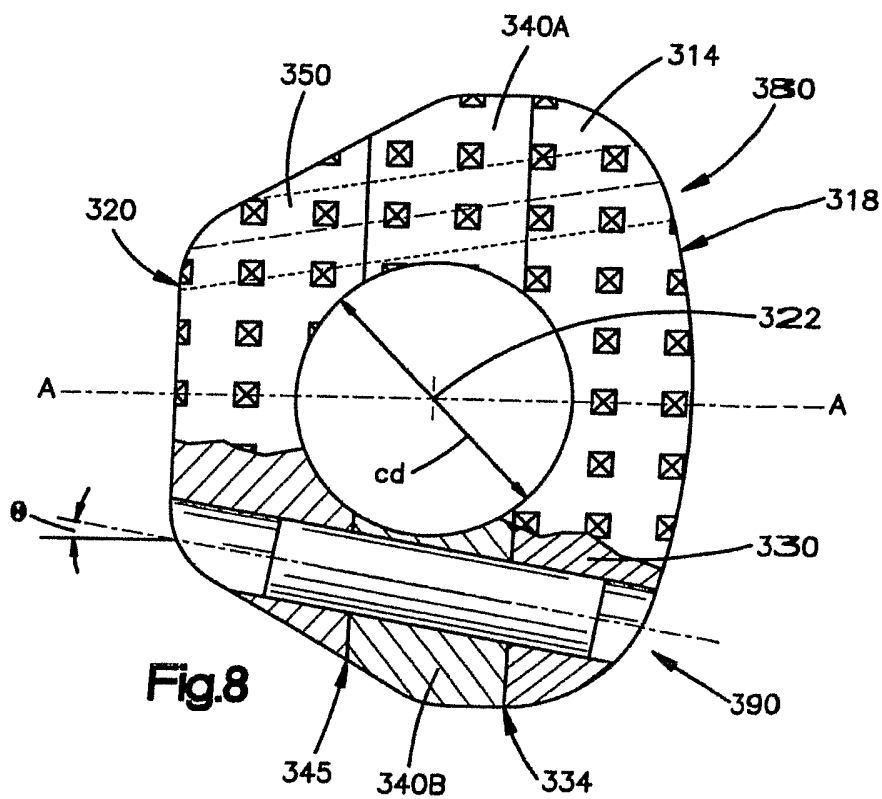
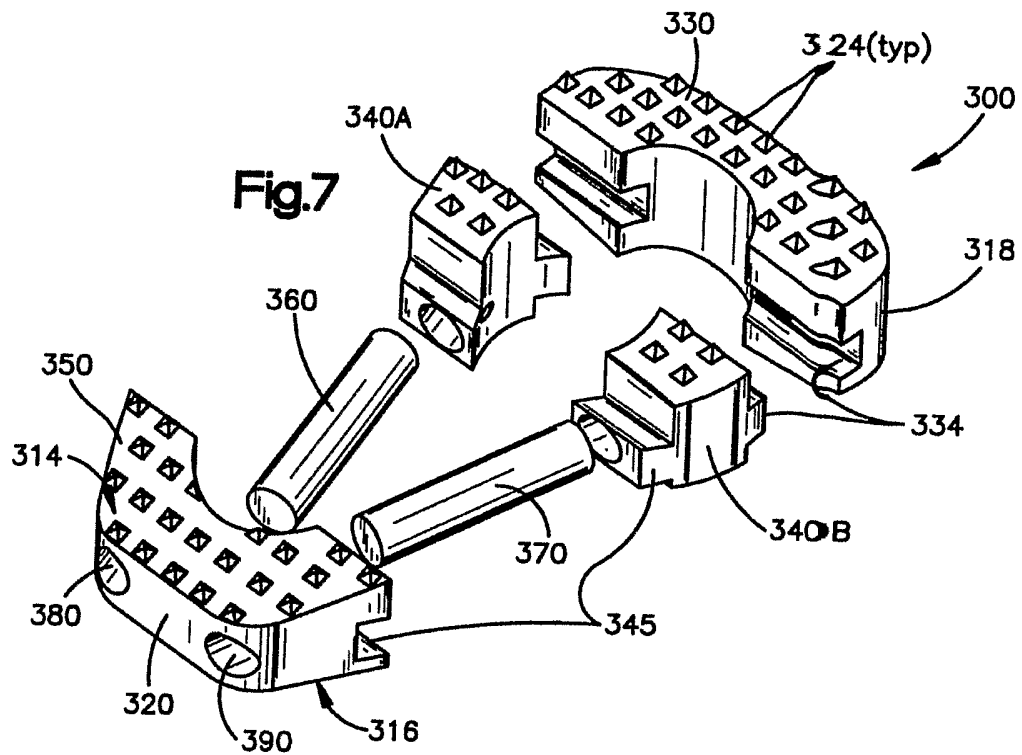
50. The multipiece implant of **claim 19**, wherein the dovetail joint is oriented on the superior surface and inferior surface of the implant.

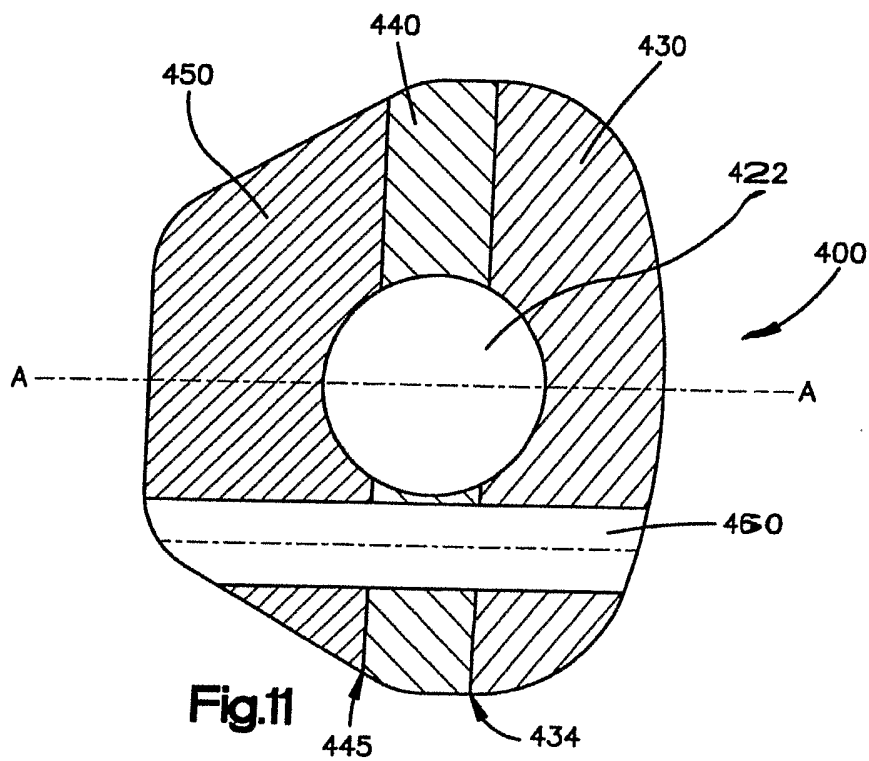
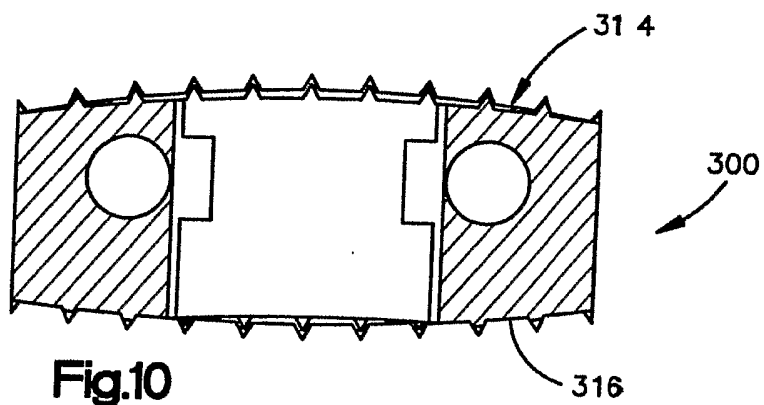
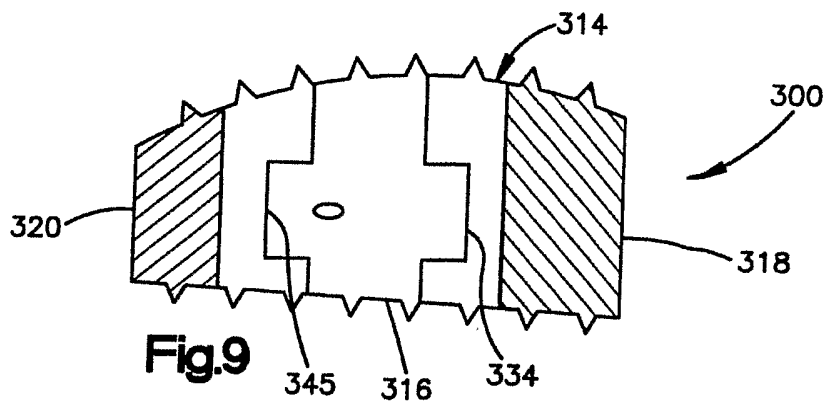


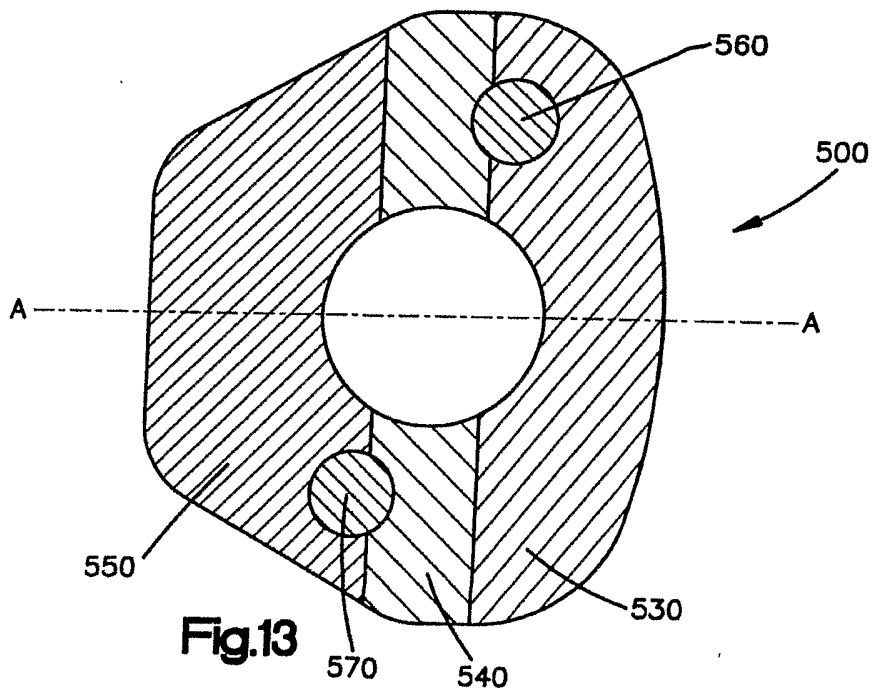
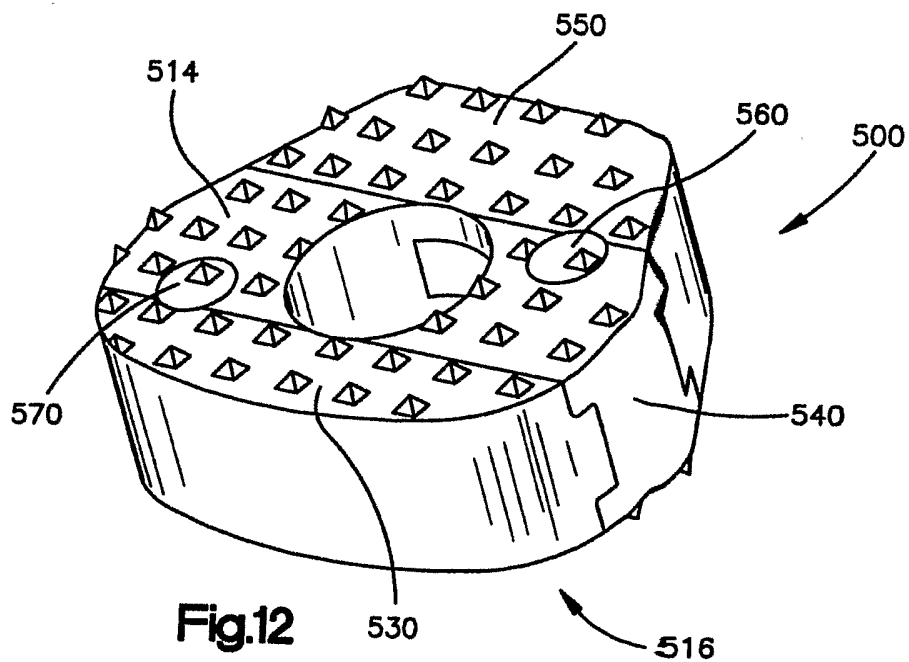












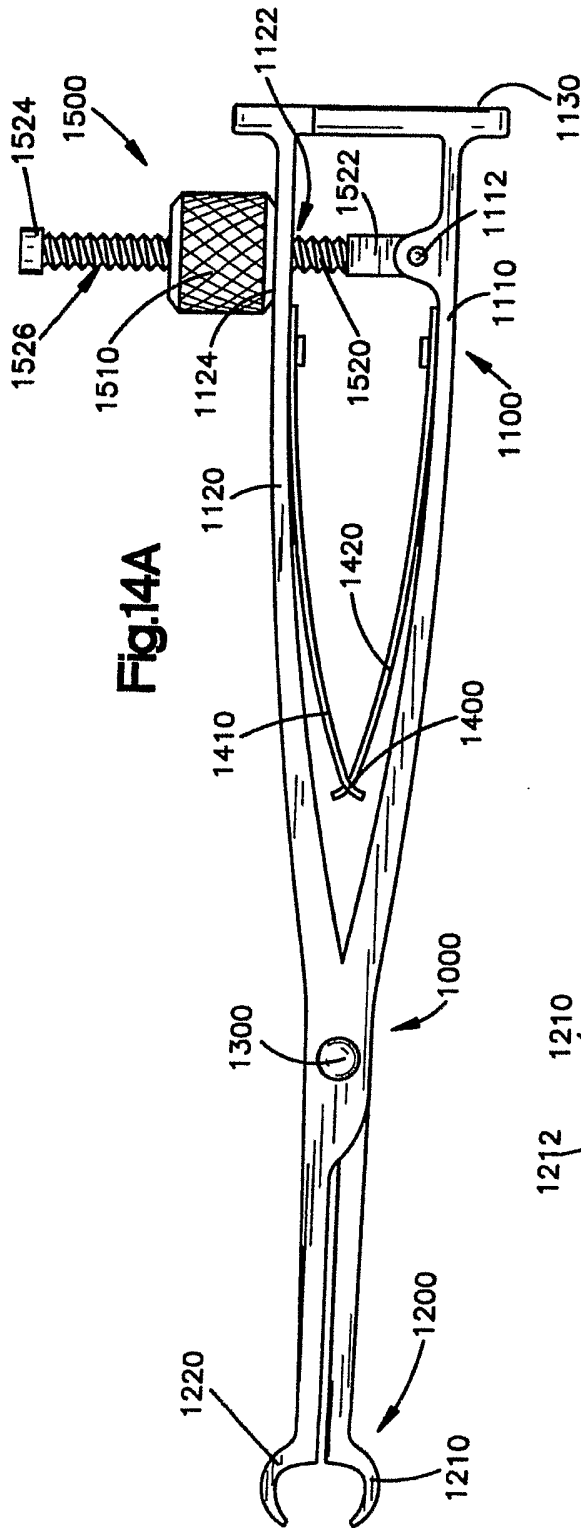


Fig.14A

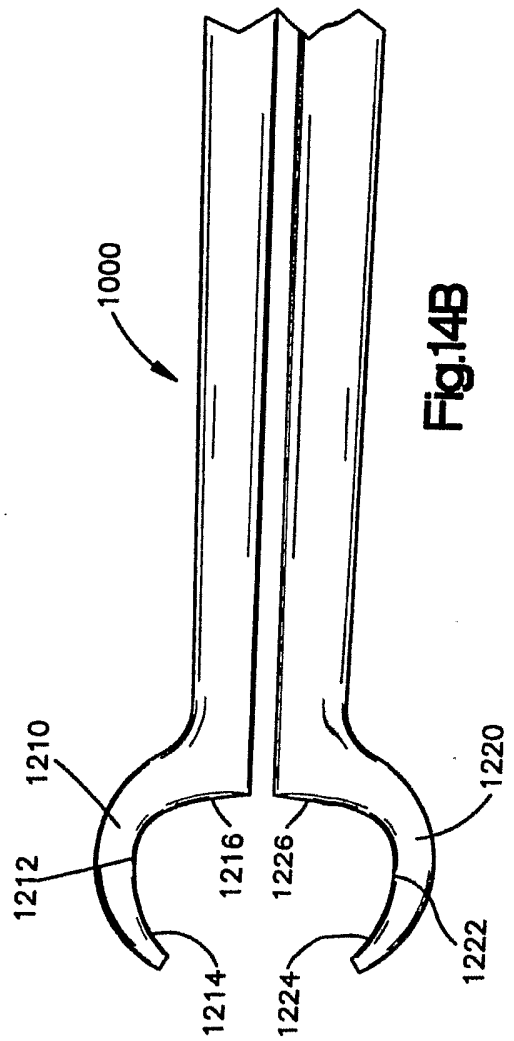
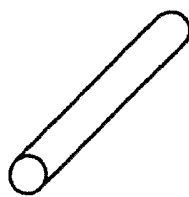
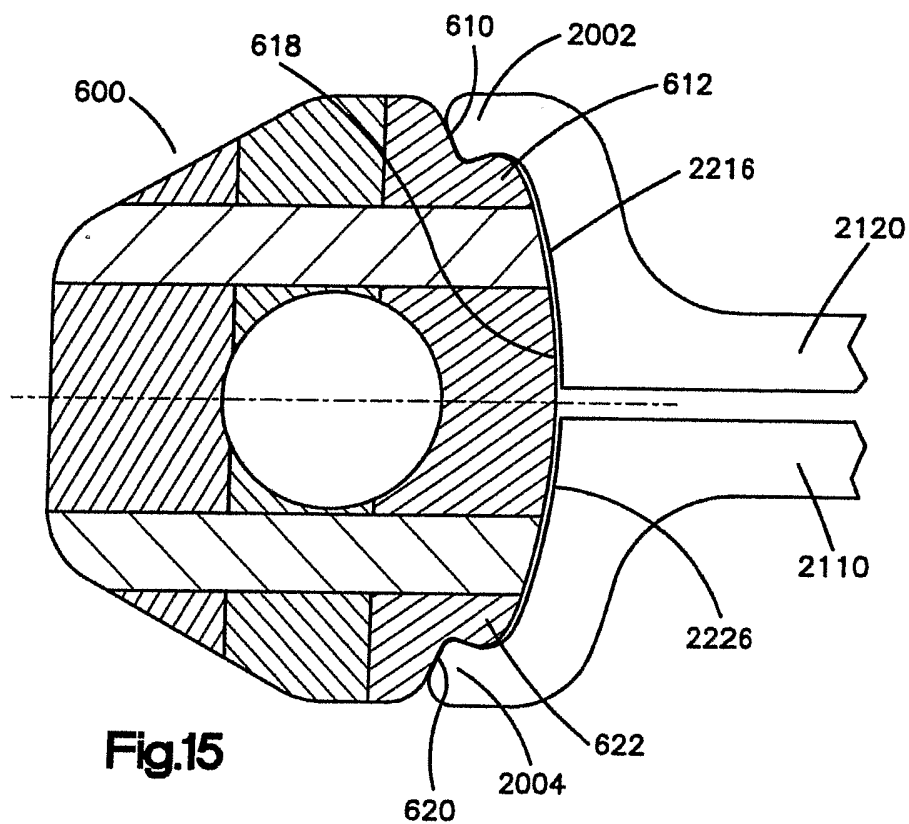
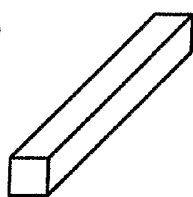


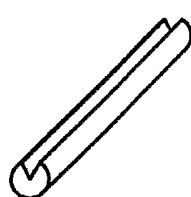
Fig.14B



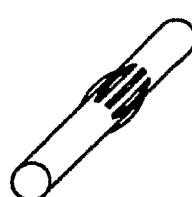
**Fig.16A**



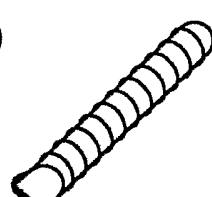
**Fig.16B**



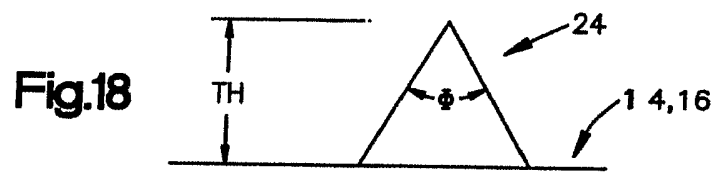
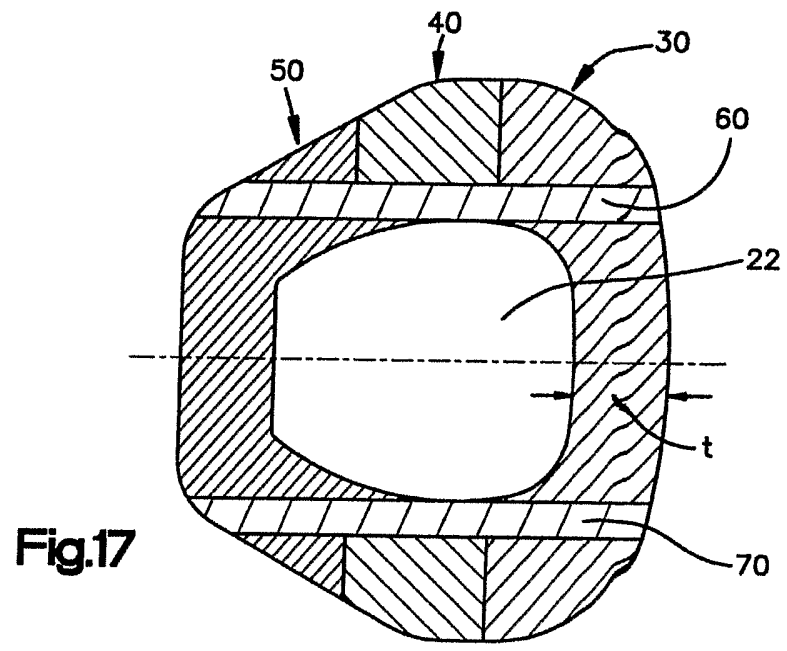
**Fig.16C**



**Fig.16D**



**Fig.16E**



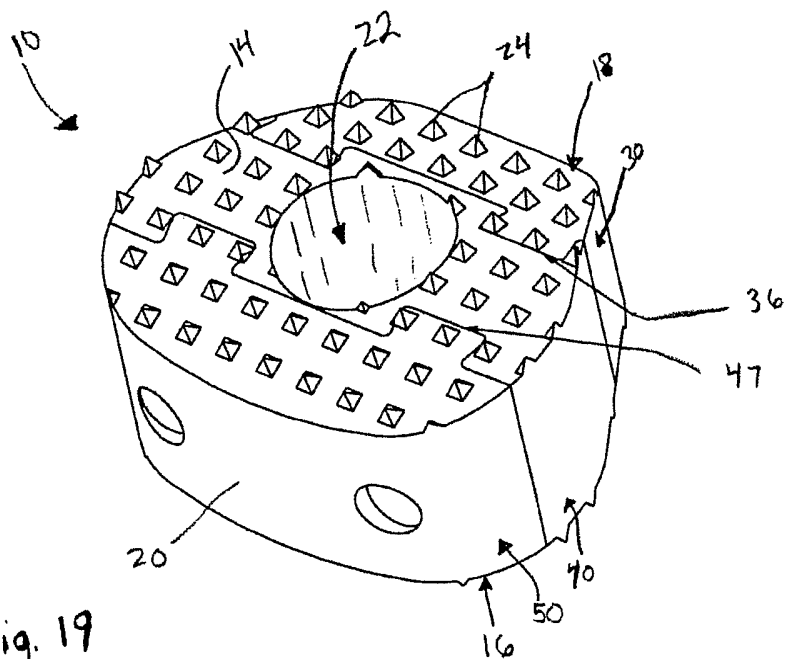


Fig. 19

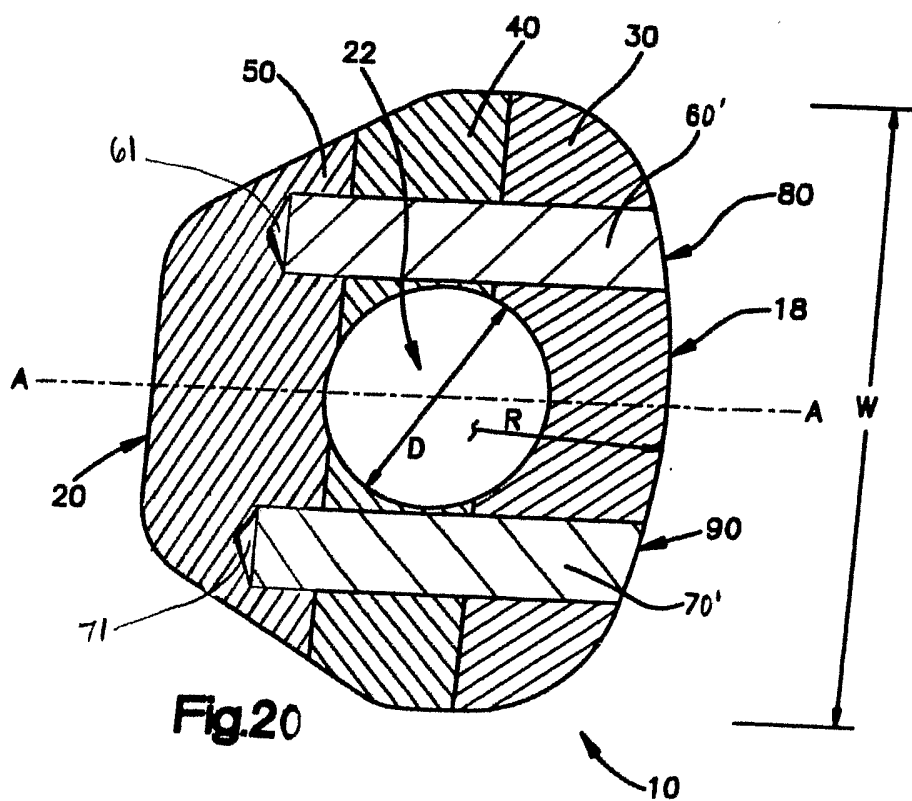


Fig. 20

Fig. 21

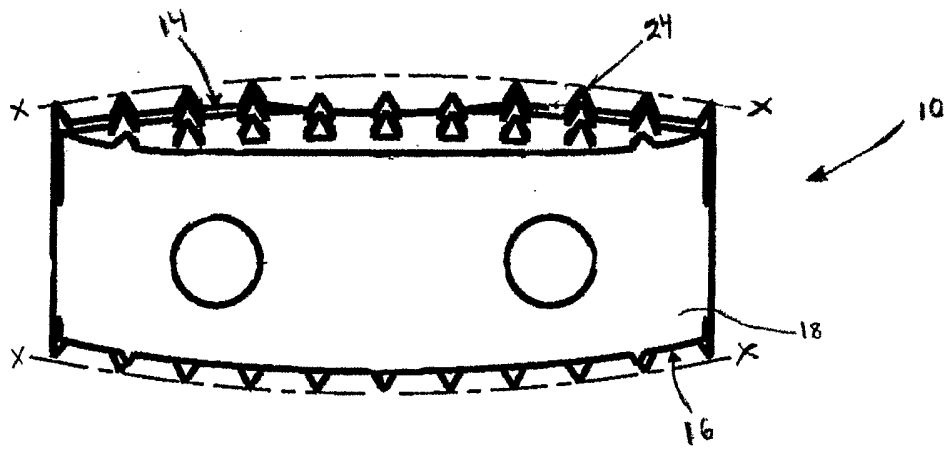




Fig. 22a

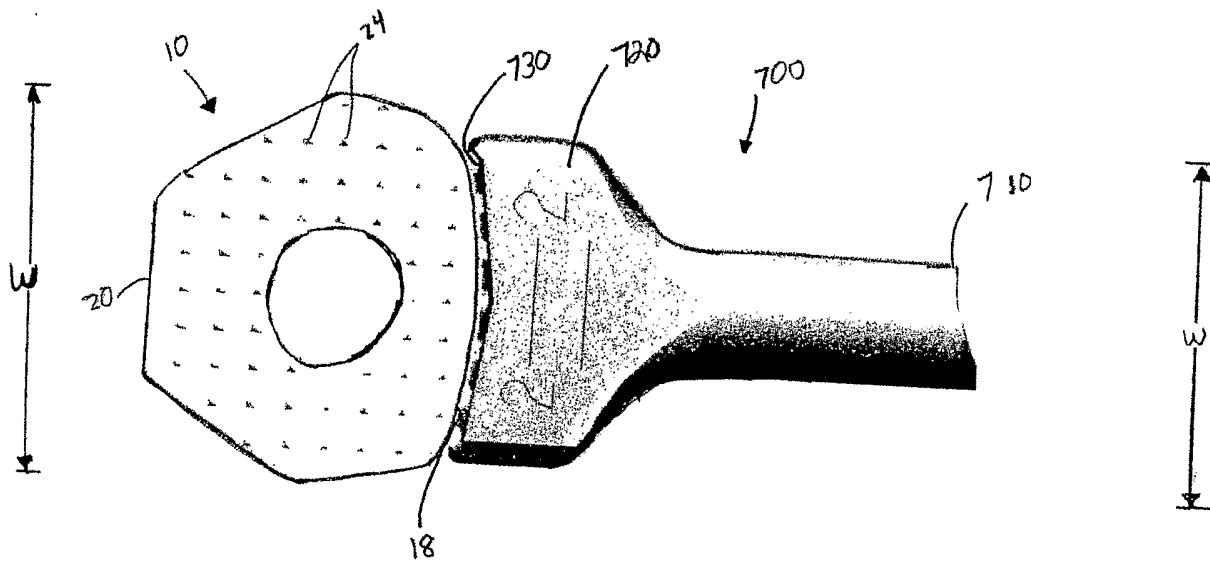


Fig. 22b

