

(19) World Intellectual Property Organization
International Bureau



(43) International Publication Date
11 January 2007 (11.01.2007)

PCT

(10) International Publication Number
WO 2007/005092 A2

- (51) International Patent Classification:
B60R 21/217 (2006.01)
- (21) International Application Number:
PCT/US2006/015812
- (22) International Filing Date: 26 April 2006 (26.04.2006)
- (25) Filing Language: English
- (26) Publication Language: English
- (30) Priority Data:
11/174,956 5 July 2005 (05.07.2005) US
- (71) Applicant (for all designated States except US): **AUTO-LIV ASP, INC.**, [US/US]; 3350 Airport Road, Ogden, Utah 84405 (US).
- (72) Inventors; and
- (75) Inventors/Applicants (for US only): **ROSE, Larry, D.** [US/US]; 2023 East Cedar Loop Drive, South Weber, Utah 84405 (US). **WILLIAMS, Jeffrey, Daniel** [US/US]; 5155 South 3025 West, Roy, Utah 84067 (US).
- (74) Agent: **KOTTIS, Nick, C.**; Pauley Peterson & Erickson, 2800 West Higgins Road, Suite 365, Hoffman Estates, Illinois 60195 (US).

- (81) Designated States (unless otherwise indicated, for every kind of national protection available): AE, AG, AL, AM, AT, AU, AZ, BA, BB, BG, BR, BW, BY, BZ, CA, CH, CN, CO, CR, CU, CZ, DE, DK, DM, DZ, EC, EE, EG, ES, FI, GB, GD, GE, GH, GM, HR, HU, ID, IL, IN, IS, JP, KE, KG, KM, KN, KP, KR, KZ, LC, LK, LR, LS, LT, LU, LV, LY, MA, MD, MG, MK, MN, MW, MX, MZ, NA, NG, NI, NO, NZ, OM, PG, PH, PL, PT, RO, RU, SC, SD, SE, SG, SK, SL, SM, SY, TJ, TM, TN, TR, TT, TZ, UA, UG, US, UZ, VC, VN, YU, ZA, ZM, ZW.
- (84) Designated States (unless otherwise indicated, for every kind of regional protection available): ARIPO (BW, GH, GM, KE, LS, MW, MZ, NA, SD, SL, SZ, TZ, UG, ZM, ZW), Eurasian (AM, AZ, BY, KG, KZ, MD, RU, TJ, TM), European (AT, BE, BG, CH, CY, CZ, DE, DK, EE, ES, FI, FR, GB, GR, HU, IE, IS, IT, LT, LU, LV, MC, NL, PL, PT, RO, SE, SI, SK, TR), OAPI (BF, BJ, CF, CG, CI, CM, GA, GN, GQ, GW, ML, MR, NE, SN, TD, TG).

Published:
— without international search report and to be republished upon receipt of that report

For two-letter codes and other abbreviations, refer to the "Guidance Notes on Codes and Abbreviations" appearing at the beginning of each regular issue of the PCT Gazette.

(54) Title: FLEXIBLE HOUSING FOR AN AIRBAG MODULE

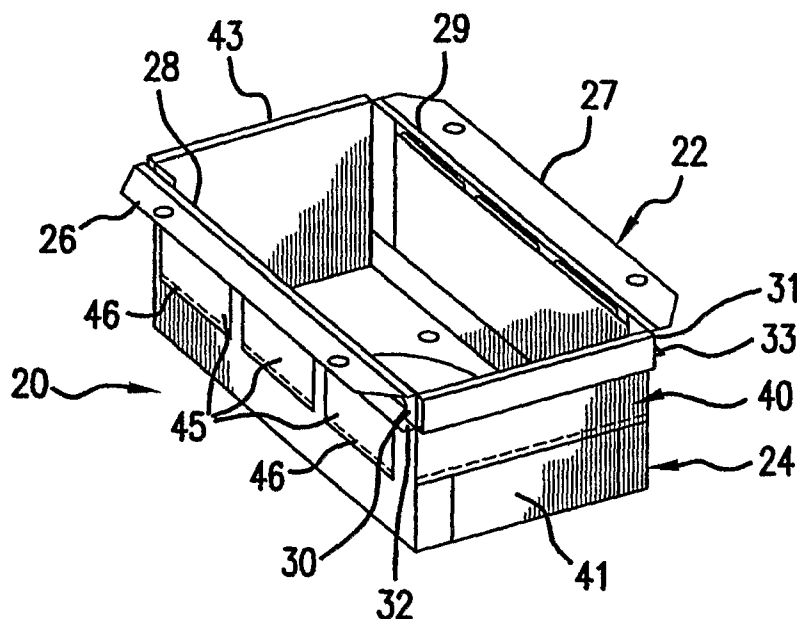

(57) Abstract: A housing for an airbag module that contains an inflatable airbag cushion in a compacted configuration before being inflated by inflation gas supplied by an inflator device. The housing includes a collar formed of a rigid material for attaching the housing to a vehicle and a chute assembly formed of a flexible material and secured to the collar.

WO 2007/005092 A2

FLEXIBLE HOUSING FOR AN AIRBAG MODULE

BACKGROUND OF THE INVENTION

This invention relates generally to an airbag module for a vehicle inflatable restraint system and, more particularly, to a housing for an airbag module.

It is well known to protect a vehicle occupant by means of safety restraint systems which self-actuate from an undeployed or static state to a deployed state without the need for intervention by the operator, i.e., "passive restraint systems." Such systems commonly contain or include an inflatable vehicle occupant restraint or element, such as in the form of a cushion or bag, commonly referred to as an "airbag cushion." In practice, such airbag cushions are typically designed to inflate or expand with gas when the vehicle encounters a sudden deceleration, such as in the event of a collision. Such airbag cushion(s) may desirably deploy into one or more locations within the vehicle between the occupant and certain parts of the vehicle interior, such as the doors, steering wheel, dashboard or the like, to prevent or avoid the occupant from forcibly striking such parts of the vehicle interior.

Various types or forms of such passive restraint assemblies have been developed or tailored to provide desired vehicle occupant protection based on either or both the position or placement of the occupant within the vehicle and the direction or nature of the vehicle collision. Automotive passenger side airbag installations generally incorporate an airbag module assembly having an inflator device within a module housing and an inflatable airbag cushion adapted to inflate out a side of the module housing. In one currently used passenger side airbag module assembly configuration the inflatable airbag cushion is adapted to inflate out a top side of the module housing, often referred to as a "top mounted" airbag cushion. Such a module assembly is installed in the dashboard of the automobile close to the windshield. Upon activation, the inflator device releases inflation gas which inflates the airbag cushion. The top mounted airbag cushion initially inflates toward the windshield and then rapidly expands down the dashboard in a direction toward the passenger.

Current passenger side airbag module assemblies often incorporate a woven nylon inflatable airbag cushion in inflation combination with a pyrotechnic or stored gas inflator device. The module housing contains the airbag in the folded, compacted configuration before inflation, and also typically contains and/or acts as a support structure for the inflator device. Typically, housings are generally rigid to perform these functions. Current

5 housings are typically formed of stamped steel or aluminum, or glass filled nylon. The costs of producing airbag module assemblies have been increasing, due at least in part to the increase in cost of the materials to form the components such as the module housing. Vehicle manufacturers, however, desire to keep production costs down. In addition to reduced costs, equivalent or similarly performing vehicle components having a reduced weight are generally desired by vehicle manufacturers in their efforts to produce more efficient vehicles.

Thus, there is a need and a demand for an airbag module of relatively simple and lightweight design and construction and, comparatively, low or reduced cost.

SUMMARY OF THE INVENTION

10 A general object of the invention is to provide an improved airbag module for vehicle airbag installations.

A more specific objective of the invention is to overcome one or more of the problems described above.

15 The general object of the invention can be attained, at least in part, through a housing for an airbag module that contains an inflatable cushion in a compacted configuration that can be inflated by inflation gas supplied by an inflator device. The housing includes a collar formed of a rigid material for attaching the housing to a vehicle. The housing also includes a chute assembly formed of a flexible material and secured to the collar.

20 As compared to the invention, the prior art generally fails to provide an airbag module housing having a lightweight design and construction, and, comparatively, a low or reduced cost to manufacture.

25 The invention further comprehends a housing for an airbag module that contains an inflatable cushion in a compacted configuration which can be inflated by inflation gas supplied by an inflator device. The housing includes a collar formed of a rigid material for attaching the housing to a vehicle. The housing also includes a fabric piece folded and stitched to form a chute assembly. The chute assembly secures to the collar to form a housing chamber for containing the inflatable cushion.

Other objects and advantages will be apparent to those skilled in the art from the following detailed description taken in conjunction with the appended claims and drawings.

BRIEF DESCRIPTION OF THE DRAWINGS

30 FIG. 1 is a perspective view of a housing for an airbag module according to one embodiment of the invention.

FIG. 2 is a perspective view of the housing of FIG. 1 prior to assembly.

FIG. 3 is an exploded view of an airbag module including the housing of FIG. 1.

FIG. 4 is a partial sectional view of the airbag module of FIG. 3 connected to a vehicle.

5 FIG. 5 is a perspective view of an airbag module of another embodiment of the invention.

FIG. 6 is a perspective view of a section of a housing of yet another embodiment of the invention.

FIG. 7 is an end view of the housing section shown in FIG. 6.

10 DETAILED DESCRIPTION OF THE INVENTION

The present invention provides a, comparatively, low or reduced cost, lightweight airbag module housing for use in a vehicle airbag module assembly. The housing of the invention uses a flexible material, such as a fabric, instead of, for example, the stamped metal typically used in traditional airbag module housings. The housing includes a flexible chute assembly secured to a rigid collar. The collar provides desired stiffness and support in the instrument panel plane to resist expansion during inflation of the inflatable airbag cushion. The collar allows for the use of the fabric chute assembly for containing the inflatable cushion when the inflatable cushion is in the folded, compacted configuration prior to inflation. The use of fabric instead of, for example, the steel or aluminum typically used in traditional airbag module housings desirably reduces material costs for the airbag module, as well as improving shipping efficiency.

FIG. 1 shows a housing 20 for an airbag module according to one embodiment of this invention. The housing 20 includes a collar 22 and a chute assembly 24 secured to the collar 22. The collar 22 is formed of a rigid material, such as, for example, metal or plastic, to provide rigid support for the housing 20. The collar can be formed as one integral rigid material piece or from two or more connected rigid material pieces. The collar 22 is used to attach the housing 20 to a vehicle, as discussed further below. The chute assembly 24 is formed of a flexible material, such as, for example, a fabric. Examples of fabrics for use in forming the chute assembly of the invention include, without limitation, nylon fabric and polyester fabric. In the embodiment of the invention shown in FIG. 1, the collar 22 has a rectangular shape or configuration, and the assembled chute assembly 24 has a corresponding rectangular, boxlike shape or configuration. As will be appreciated by those skilled in the art,

various and alternative materials, shapes and/or configurations are available for forming the housing, collar and/or chute assembly of the invention.

5 The collar 22 includes a pair of vehicle attachment flanges 26 and 27 for attaching the collar 22 to a vehicle. The vehicle attachment flanges 26 and 27 extend outwardly at an angle, e.g., substantially perpendicular, from first edges 28 and 29 on two
10 opposing sides 30 and 31, respectively, of the collar 22. The collar 22 also includes a pair of chute flanges 32 and 33 extending outwardly at an angle, e.g., substantially perpendicular, from the collar edges opposite first edges 28 and 29, respectively, on sides 30 and 31. The outwardly extending vehicle attachment flanges 26 and 27 and the chute flanges 32 and 33 on
15 the collar sides 30 and 31 provide the collar 22 with a "C-shaped" configuration that provides planar stiffness, and desirably reduces and/or eliminates deformation of the collar 22 during deployment of an inflatable cushion. As shown in FIG. 2, the collar 22 includes a plurality of tab openings 36 that are disposed through portions of the collar 22 adjacent the vehicle attachment flange 26 and 27, respectively. Tab openings 36 are disposed in each of the collar
sides 30 and 31, between the vehicle attachment flanges 26 and 27 and the chute flanges 32 and 33, respectively.

Referring again to FIG. 1, the chute assembly 24 includes an attachment portion 40 folded over, about or around a portion of the collar 22. The attachment portion 40 desirably extends around a top portion or edge of the chute assembly 24, and is folded about each of the
20 sides of the collar 22, e.g., sides 30 and 31. The chute assembly 24 is secured about the collar 22 by attaching the folded attachment portion 40 to the sides or side walls, e.g., side wall 41, of the chute assembly 24. The folded attachment portion 40 desirably secures to the chute assembly sides at or toward an attachment portion end opposite the folded end 43 of the attachment portion 40.

25 In one embodiment of the invention, the folded attachment portion 40 attaches to the sides of the chute assembly 24 by a plurality of stitches 46. As will be appreciated by those skilled in the art following the teachings herein provided, various and alternative types, patterns, and/or numbers of stitches are available for attaching the folded attachment portion 40 to the sides of the chute assembly 24, depending upon factors such as, for example, the
30 strength of the fabric and/or the stitching thread material. In one embodiment of the invention, the stitching is a lock or chain stitch that runs generally straight and parallel to the collar 22.

While the invention is described herein with the chute assembly attached to the collar by the attachment portion being folded over the collar and secured to the side wall of the chute assembly, the invention is not intended to be so limited. Other alternative means for securing the chute assembly to the collar are also available for the housing of the invention.

5 In alternative embodiments of the invention, the chute assembly can be secured to the collar with or without folding of a portion of the chute assembly over or around the collar. In one embodiment of this invention, the chute assembly is secured to the collar by adhesive bonding, ultrasonic bonding or insert molding of the fabric to the collar. Buttons, snaps or rivets can also be used to attach the fabric of the chute assembly to the collar. The collar or the chute

10 assembly can also include hooks that hook to corresponding hook openings in, or metal loops attached to, the chute assembly fabric or the collar, respectively. The chute assembly can also be attached to the collar by a rod or pin that extends through one or more fabric loops disposed about the open end edge of the chute assembly. In one embodiment, the rod or pin can slide through a loop in the fabric and then slide into a receiving channel of the collar. In another

15 embodiment, the fabric and the collar include a plurality of alternating loops that, when aligned, the rod or pin is passed through like a door hinge. In yet another embodiment, the rod or pin can pass through a plurality of spaced fabric loops in the chute assembly, and the rod can then be snapped or otherwise attached to a plurality of collar hooks.

FIG. 2 shows two overlaid cut pieces of fabric 42 before being folded and

20 sewed to form the chute assembly 24. As will be appreciated by those skilled in the art following the teachings herein provided, the chute assembly 24 can alternatively be formed from a single piece of fabric or more than two pieces of fabric sewn or otherwise attached together. The chute assembly 24 includes an inflator opening 47 disposed in a bottom side wall 44 through which an inflator device (not shown), e.g., desirably an inflation gas diffuser

25 of the inflator device, can be introduced into the housing 20. FIG. 2 also shows how the chute assembly attachment portion 40 can be folded about the collar 22 in the area of the vehicle attachment flanges 26 and 27. The attachment portion 40 includes a plurality of attachment tabs 45. Each of the plurality of attachment tabs 45 is sized or configured to extend through a corresponding one of the tab opening 36 disposed in the collar 22. As shown in FIG. 1, the

30 attachment tabs 45 each extend through a corresponding tab opening 36, are folded about the collar 22 and attached, desirably by the plurality of stitches 46, to the sides of the chute assembly 24. The attachment tabs 45 and the tab openings 36 allow the attachment portion 40

to be secured about the portions or sides of the collar 22 adjacent the vehicle attachment flanges 26 and 27 without extending over or about the vehicle attachment flanges 26 and 27. As will be appreciated by those skilled in the art following the teachings herein provided, various and alternative sizes, shapes and numbers of tab openings and attachment tabs are available for use in the housing of the invention.

The attachment tabs 45 are also folded over the chute flanges 32 and 33, respectively. The folding of the attachment tabs 45 over the chute flanges 32 and 33 can desirably provide lateral support for the sides of the chute assembly 24 by providing a structural connection between the chute assembly 24 and the collar 22.

FIG. 3 shows an exploded view of an airbag module 48 including the housing 20 of FIG. 1. An inflator device 50 is disposed beneath the housing 20. The inflator device 50 shown in FIG. 3 is a disk-shaped inflator device, such as is commonly used in driver and/or passenger side airbag assemblies. As will be appreciated by those skilled in the art following the teachings herein provided, various and alternative inflator devices, such as, for example, a cylindrical side-discharge inflator device, are available for use with the invention. Desirably, a portion of the inflator device 50, such as an inflation gas diffuser 52, extends through the inflator opening 47 of the housing 20. A mounting bracket 54 is used to connect the inflator device 50 to the vehicle. The housing 20 is secured to the inflator device 50 by a retainer deflector 60. The retainer deflector 60 is disposed within a housing chamber 62 and an inflatable cushion 70, and connects to the inflator device by bolts 64 through the housing bottom side wall 44. The retainer deflector 60 includes a circular opening 66, adapted to fit over and surround the inflator diffuser 52.

The inflatable cushion 70 is disposed, at least partially, within the housing chamber 62 when the inflatable cushion 70 is in the compacted configuration prior to inflation. The inflatable cushion 70 is connected to the retainer deflector 60. The inflatable cushion 70 has an opening (not shown) that connects over the retainer deflector 60 and is clamped between the retainer deflector 60 and the housing 20, such that the inflator diffuser 52 is in inflation combination with the inflatable cushion 70. Upon receipt of an activation signal, the inflator device 50 supplies inflation gas through the inflator diffuser 52 to inflate the inflatable cushion 70. The inflatable cushion 70 inflates out the open end of the housing 20 defined by the collar 20. The retainer deflector 60 desirably includes at least one deflector portion 68 which directs inflation gas toward the open end of the housing 20 instead of laterally toward

the side walls of the inflatable cushion 70 and housing 20, thereby promoting desired upward inflation of the inflatable cushion 70. As will be appreciated by those skilled in the art following the teachings herein provided, the retainer diffuser is sized and shaped according to the size and shape of the housing and/or inflator device. As will be further appreciated, a
5 retainer deflector may not be needed for use with particular inflator devices and/or airbag module configurations.

FIG. 4 shows the airbag module 48 connected to an instrument panel 80 of a vehicle. The housing 20 is fastened, such as by one or more fasteners 82, to the instrument panel 80. The instrument panel 80 includes a weakening or crease 84, which is opened by an
10 inflating inflatable cushion 70. The mounting bracket 54 secures the inflator device 50 to a beam 86 of the vehicle. The beam 86 supports the weight of the inflator device 50, the inflatable cushion 70 and the mounting bracket 54, thereby advantageously removing weight from the instrument panel 80. The lower mounting by the mounting bracket 54 also desirably supports the snap loading of the inflatable cushion 70 during inflatable cushion 70 deployment,
15 and holds the inflator device 50 and retainer deflector 60 in position during loading.

The housing and/or airbag module of the invention further provide(s) the following additional advantages over the prior art stamped metal housings. The flexible material of the housing generally reduces both cost and weight, as compared to the stamped metal housings typically used currently in airbag modules. The flexible chute assembly also
20 allows changing of the deployment angle for the inflatable cushion without stamping retooling, which can allow for design flexibility and reduced engineering time for vehicle manufacturers. Furthermore, the collapsibility of the flexible housing provides better shipping efficiency, as compared to the rigid and bulkier metal housings. When installed, the flexible housing can also desirably provide or allow for improved head impact properties of the instrument panel.

FIG. 5 illustrates an airbag module 100 according to another embodiment of the invention. The airbag module 100 has a housing 120 including a collar 122 and a chute assembly 124 secured to the collar 122. As discussed above, the chute assembly 124 is formed of a flexible material. The collar 122 is formed of a rigid material to provide rigid support for
25 the housing 120 and for attaching the housing 120 to a vehicle.

The collar 122 includes a pair of vehicle attachment flanges 126 and 127 for attaching the collar 122 to the vehicle. The vehicle attachment flanges 126 and 127 each include a plurality of attachment hooks 128 for attaching the collar to the vehicle. The collar
30

122 further differs from the collar 22 discussed above in that the collar 122 includes only two tab openings 130. However, as discussed above, the invention is not intended to be limited to a particular number of tab openings, as various and alternative numbers of tab openings can be used in the collar of the invention, depending on need. The two tab openings 130 are disposed on opposing sides of the collar 122.

The chute assembly 124 is desirably formed of a fabric material and has an alternative shape or configuration to the chute assembly 24 discussed above. The attachment portion 140 is folded over a portion of the collar 122 and secured to the outer side of the chute assembly 124 by a plurality of stitches. The attachment portion 140 includes two attachment tabs 145. Each of the attachment tabs 145 extends through a corresponding tab opening 130 and is folded over or about a portion of the collar 122. As discussed above, an inflatable cushion 132 is contained within the housing 120 and an inflator device 134 is disposed in inflation combination with the inflatable cushion 132 through the housing 120. A mounting bracket 136 is connected to the inflator device 134 for connecting the inflator device 134 to a vehicle.

FIGS. 6 and 7 illustrate another alternative embodiment of a collar and chute assembly for the housing of the invention. FIG. 6 shows a perspective view of a section of a housing 200. FIG. 7 is an end view of the housing section shown in FIG. 6.

The housing 220 includes a collar 222 formed of a rigid material, such as metal, and a chute assembly 224 formed of a flexible material, such as a fabric. The collar 222 includes a vehicle attachment flange 226 extending outwardly from the collar 222 for attaching the collar 222 to a vehicle. The vehicle attachment flange 226 includes a plurality of fastener openings 228, through which a fastener (not shown) such as a bolt, can extend for attaching the vehicle attachment flange 226, and the housing 220, to a vehicle. As shown in FIG. 7, the collar 222 also includes an outwardly extending chute flange 232 opposite the vehicle attachment flange 226, thereby providing the collar 222 with a "C-shaped" configuration.

The chute assembly 224 includes an attachment portion 240 folded over or about the collar. In the embodiment of the invention shown in FIGS. 6 and 7, the attachment portion 240 is folded over or about the vehicle attachment flange 226 and secured to the side wall 241 of the chute assembly 224 by a plurality of stitches 242. The attachment portion 240 includes a plurality of flange openings 244. Each of the flange openings 244 is aligned with one of a plurality of fastener openings 228. The flange openings 244 are desirably sized to

reduce or eliminate obstruction of the fastener openings 228 during attachment of the housing 220 to a vehicle. As will be appreciated by those skilled in the art following the teachings herein provided, various sizes, shapes and configurations are available for the flange openings and the fastener openings. In one embodiment of the invention, the vehicle attachment flange includes a plurality of attachment hooks, such as discussed above and shown in FIG. 5, the attachment portion folds over the vehicle attachment flange, and each of the chute assembly flange openings is aligned with one of a plurality of attachment hooks.

Thus, the invention provides an improved airbag module housing, as compared to the traditional stamped metal housings. The flexible material of the housing generally reduces both cost and weight over the stamped metal housings typically used for airbag modules. Furthermore, the collapsibility of the flexible housing provides better shipping efficiency of the rigid metal housing currently used.

The invention illustratively disclosed herein suitably may be practiced in the absence of any element, part, step, component, or ingredient which is not specifically disclosed herein.

While in the foregoing detailed description this invention has been described in relation to certain preferred embodiments thereof, and many details have been set forth for purposes of illustration, it will be apparent to those skilled in the art that the invention is susceptible to additional embodiments and that certain of the details described herein can be varied considerably without departing from the basic principles of the invention.

What is claimed is:

1. A housing for an airbag module that contains an inflatable cushion in a compacted configuration, the inflatable cushion inflated by inflation gas supplied by an inflator device, the housing comprising:
a collar formed of a rigid material for attaching the housing to a vehicle; and
a chute assembly formed of a flexible material and secured to the collar.
2. The housing of claim 1 wherein the flexible material comprises a fabric.
3. The housing of claim 2 wherein the flexible material comprises a nylon fabric or a polyester fabric.
4. The housing of claim 1 wherein the rigid material comprises metal.
5. The housing of claim 1 wherein the rigid material comprises plastic.
6. The housing of claim 1 wherein the collar is formed from one rigid material piece.
7. The housing of claim 1 wherein the collar is formed from more than one rigid material piece.
8. The housing of claim 1 wherein the collar comprises a vehicle attachment flange for attaching the collar to the vehicle.
9. The housing of claim 8 wherein the vehicle attachment flange comprises a plurality of attachment hooks.
10. The housing of claim 1 wherein the chute assembly comprises an inflator opening adapted to receive an inflation gas diffuser connected to the inflator device.

11. An airbag module for protecting an occupant of a vehicle from an impact, the airbag module comprising:

the housing of claim 1;

an inflatable cushion in a compacted configuration contained in the housing;

and

an inflator device in inflation combination with the inflatable cushion, wherein upon receipt of an activation signal, the inflator device supplies inflation gas to inflate the inflatable cushion.

12. The airbag module of claim 11 wherein an inflation gas diffuser connected to the inflator device is disposed through an inflator opening in the chute assembly.

13. The airbag module of claim 11 additionally comprising a retainer deflector disposed in the housing and connected to the inflator device, wherein the retainer deflector secures the chute assembly to the inflator device.

14. The airbag module of claim 13, wherein a portion of the inflatable cushion is disposed between the retainer deflector and the chute assembly.

15. A housing for an airbag module that contains an inflatable cushion in a compacted configuration, the inflatable cushion inflated by inflation gas supplied by an inflator device, the housing comprising:

a collar formed of a rigid material for attaching the housing to a vehicle; and

a fabric piece folded and stitched to form a chute assembly, the chute assembly secured to the collar to form a housing chamber for containing the inflatable cushion.

16. The housing of claim 15 wherein the flexible material comprises a nylon fabric or a polyester fabric.

17. The housing of claim 15 wherein the rigid material comprises metal.

18. The housing of claim 15 wherein the rigid material comprises plastic.

19. The housing of claim 15 wherein the collar comprises a vehicle attachment flange for attaching the collar to the vehicle.

20. An airbag module for protecting an occupant of a vehicle from an impact, the airbag module comprising:

the housing of claim 15;

an inflatable cushion in a compacted configuration contained in the housing;

and

an inflator device in inflation combination with the inflatable cushion, wherein upon receipt of an activation signal, the inflator device supplies inflation gas to inflate the inflatable cushion.

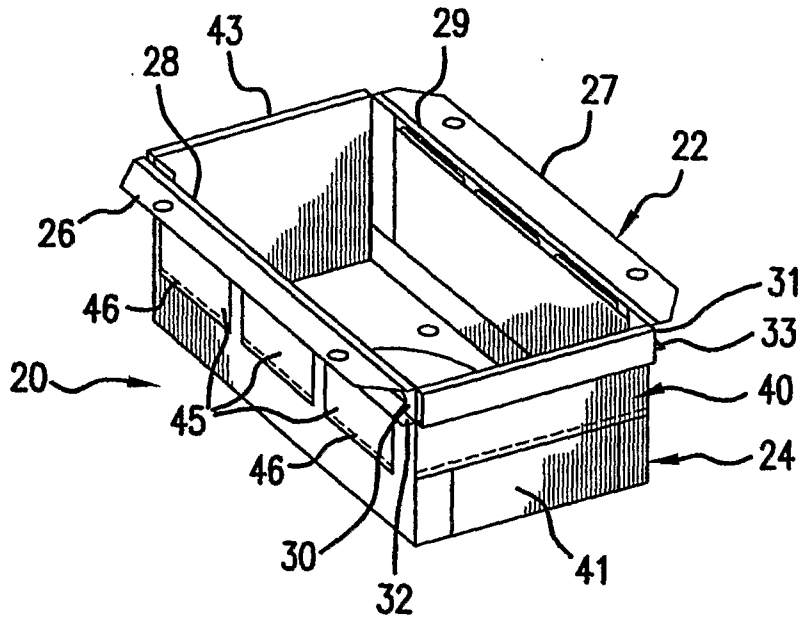

FIG. 1

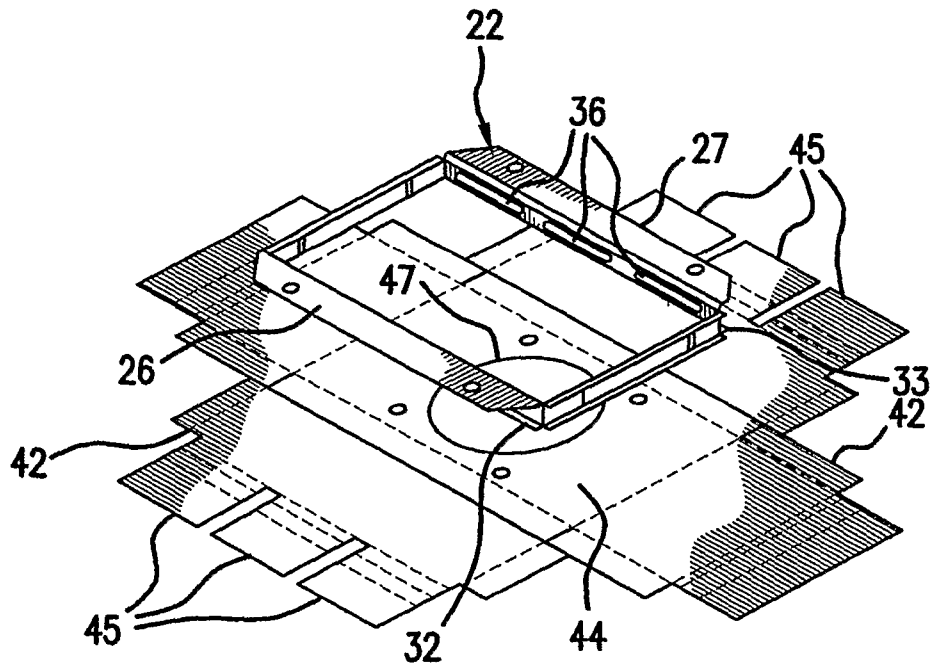

FIG. 2

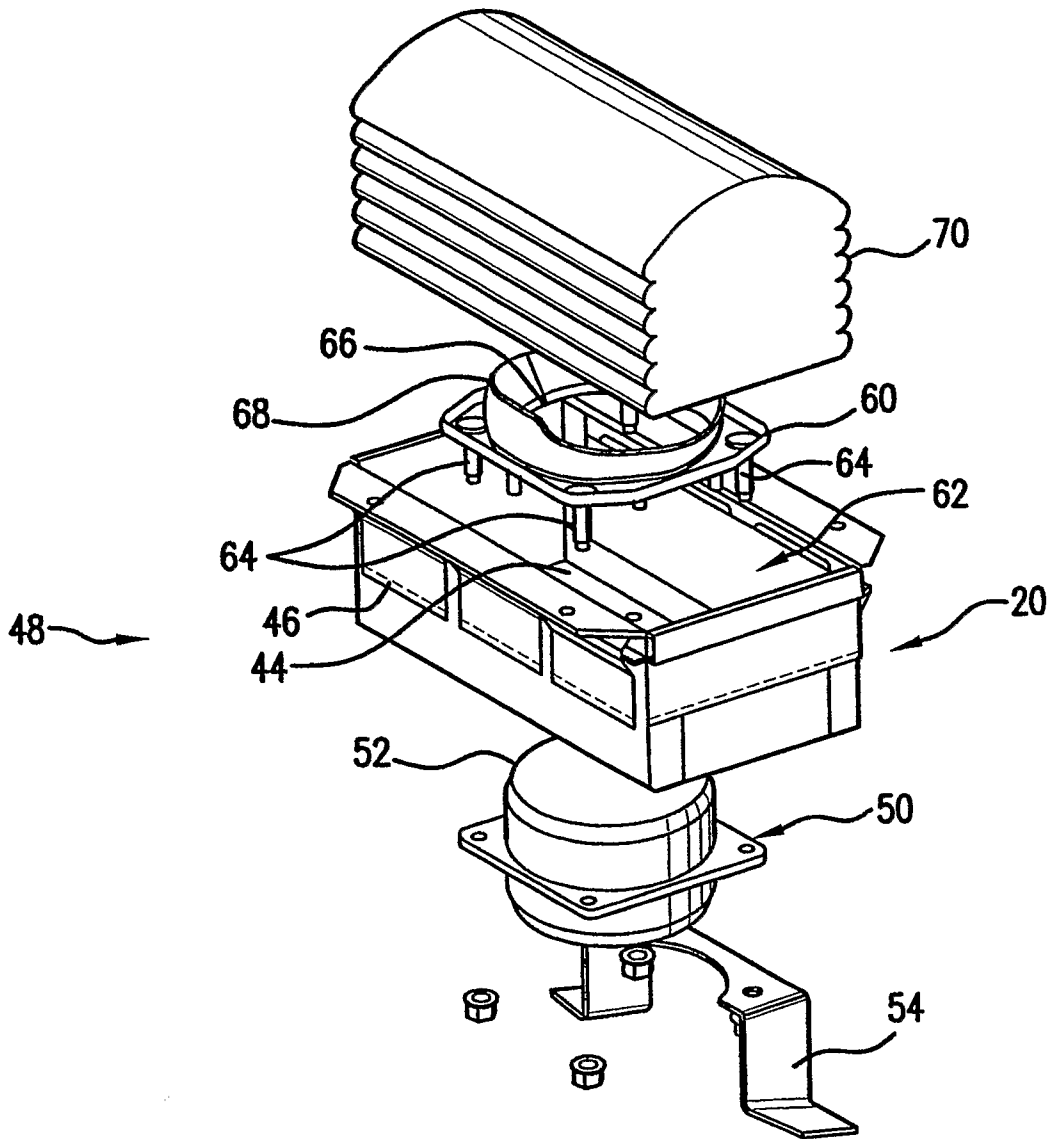

FIG.3

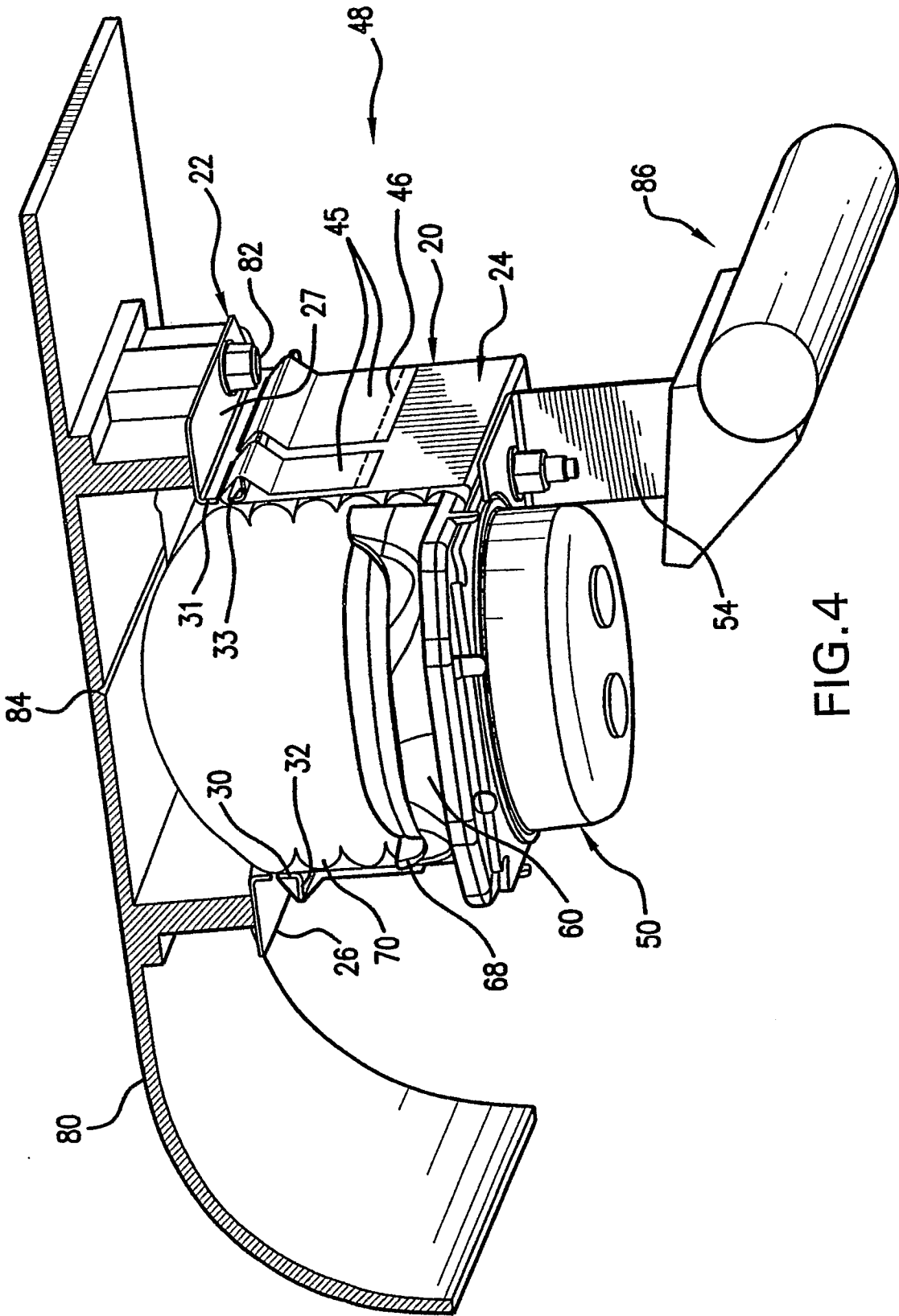

FIG.4

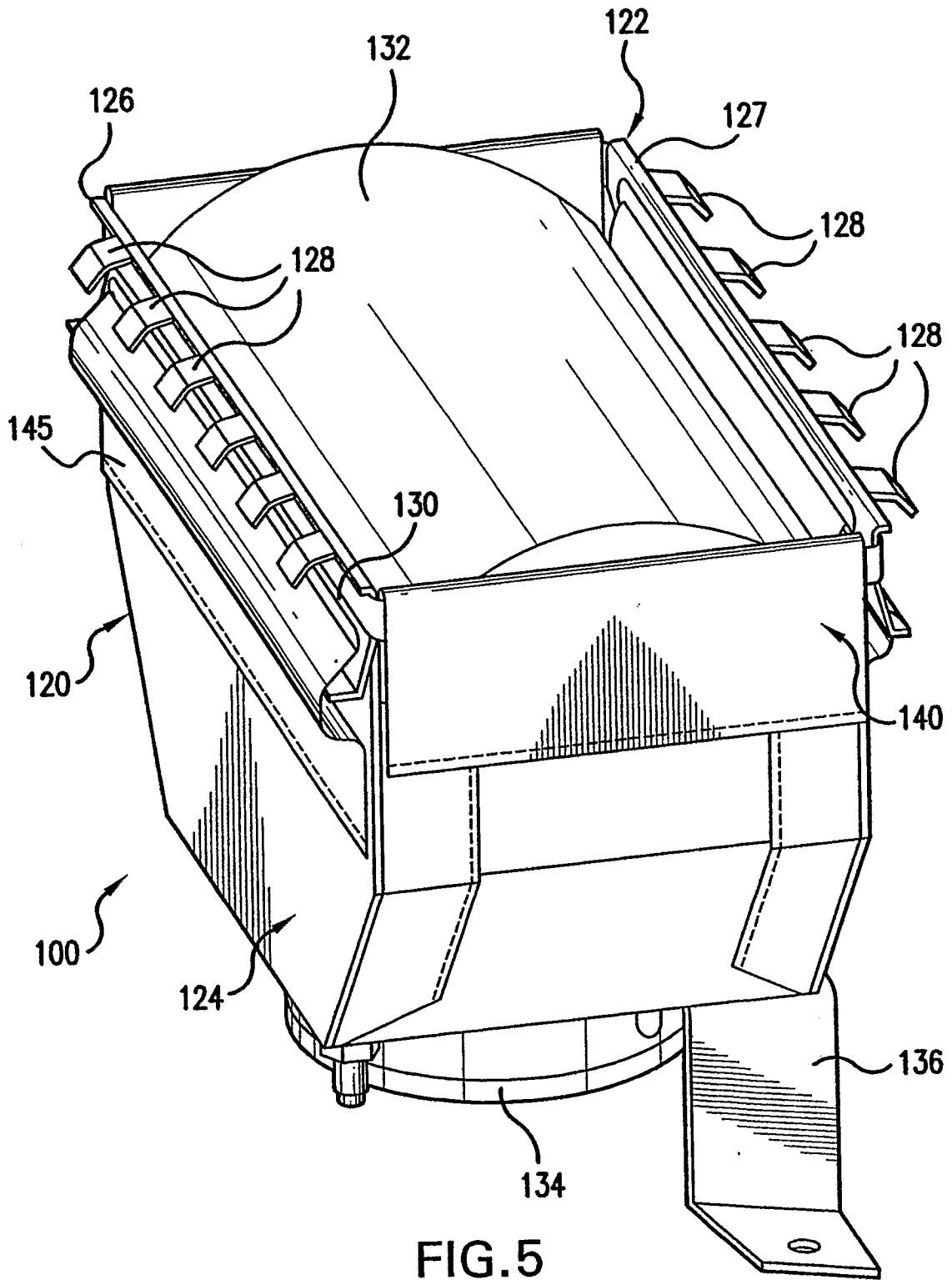

FIG. 5

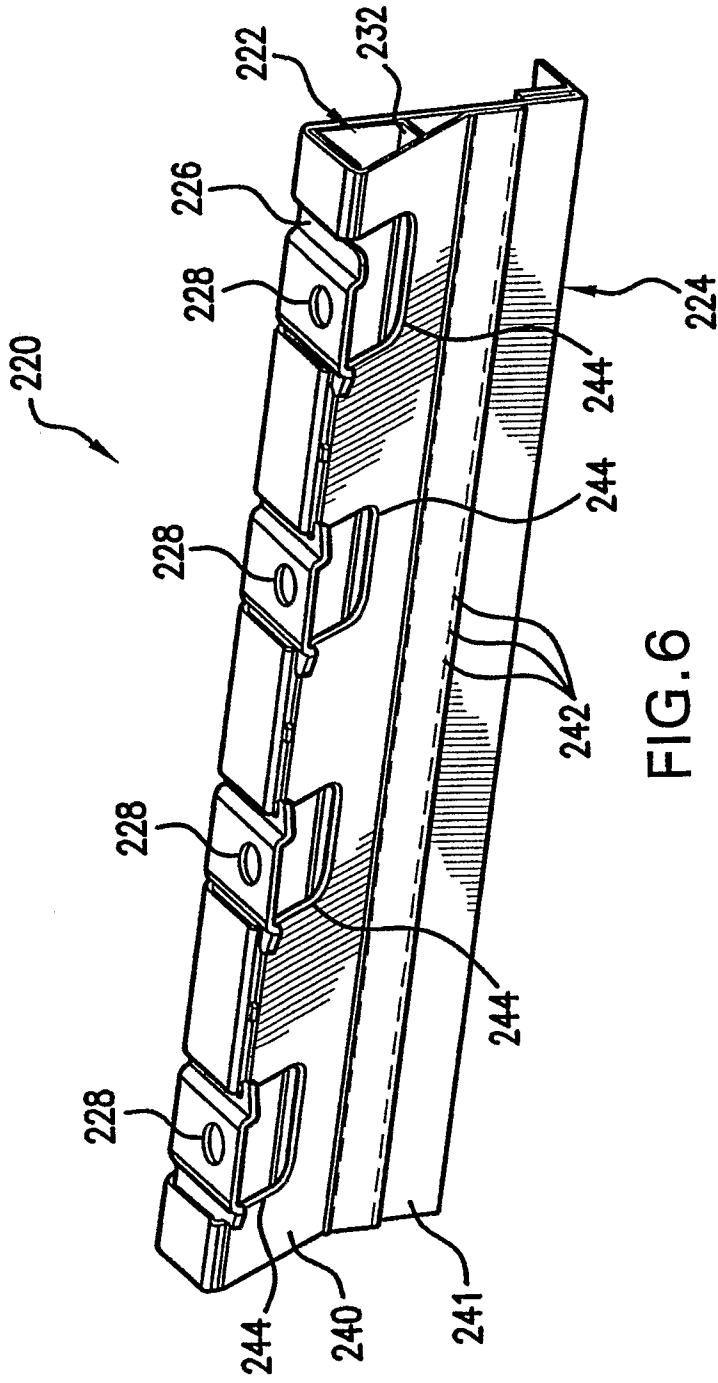

FIG. 6

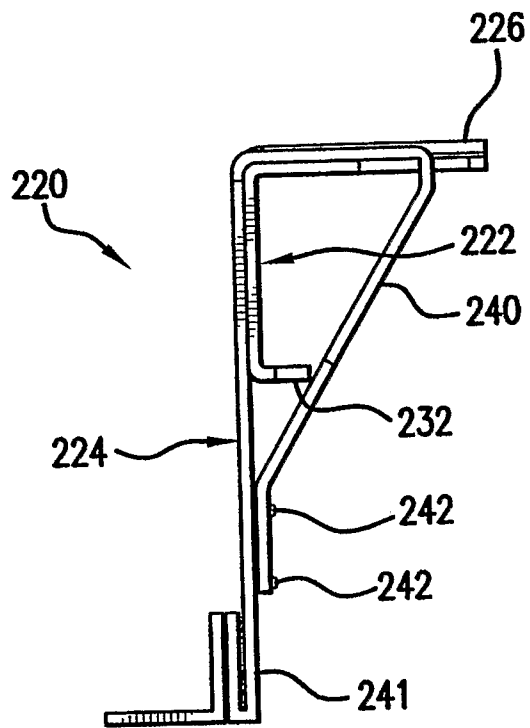

FIG. 7