

**(12) PATENT**  
**(19) AUSTRALIAN PATENT OFFICE**

**(11) Application No. AU 199949356 B2**  
**(10) Patent No. 765276**

(54) Title  
Chimaeric adenoviruses

(51) <sup>6</sup> International Patent Classification(s)  
C12N 015/86 C12N 005/10

(21) Application No: 199949356 (22) Application Date: 1999.07.08

(87) WIPO No: W000/03029

(30) Priority Data

(31) Number	(32) Date	(33) Country
98202297	1998.07.08	EP

(43) Publication Date : 2000.02.01  
(43) Publication Journal Date : 2000.04.13  
(44) Accepted Journal Date : 2003.09.11

(71) Applicant(s)  
Crucell Holland B.V.

(72) Inventor(s)  
Menzo Havenga; Ronald Vogels; Abraham Bout

(74) Agent/Attorney  
Davies Collison Cave, 1 Little Collins Street, MELBOURNE VIC 3000



(56) Related Art  
JOURNAL OF VIROLOGY, 70(4), 1996, GALL ET AL, 2116-23  
WO 96/26281  
AU 64652/98

PCT

WORLD INTELLECTUAL PROPERTY ORGANIZATION  
International Bureau



INTERNATIONAL APPLICATION PUBLISHED UNDER THE PATENT COOPERATION TREATY (PCT)

<p>(51) International Patent Classification <sup>7</sup> : C12N 15/86, 5/10</p>	<p>A2</p>	<p>(11) International Publication Number: <b>WO 00/03029</b> (43) International Publication Date: 20 January 2000 (20.01.00)</p>
<p>(21) International Application Number: PCT/NL99/00436 (22) International Filing Date: 8 July 1999 (08.07.99) (30) Priority Data: 98202297.2 8 July 1998 (08.07.98) EP <i>Cruceel Holland B.V.</i> (71) Applicant: INTROGENE B.V. (NL/NL); Wassenaarseweg 72, NL-2333 AL Leiden (NL). <i>Archieverweg 4 2333 CA Leiden</i> (72) Inventors: HAVENGA, Menzo; Stortemelk 57, NL-2401 BV Alphen aan den Rijn (NL). VOGELS, Ronald; Van Rietlaan 4, NL-3461 HW Linschoten (NL). BOUT, Abraham; Coymansstraat 24, NL-2751 AR Moerkapelle (NL). (74) Agent: OTTEVANGERS, S., U.; Vereenigde Octroobureaux, Nieuwe Parklaan 97, NL-2587 BN The Hague (NL).</p>	<p>(81) Designated States: AU, CA, JP, MX, NZ. <b>Published</b> <i>Without international search report and to be republished upon receipt of that report.</i></p>  	
<p>(54) Title: CHIMAERIC ADENOVIRUSES (57) Abstract The present invention provides methods and vector systems for the generation of chimaeric recombinant adenoviruses. These hybrid adenoviruses contain a genome that is derived from different adenovirus serotypes. In particular, novel hybrid adenoviruses are disclosed with improved properties for gene therapy purposes. These properties include: a decreased sensitivity towards neutralizing antibodies, a modified host range, a change in the titer to which adenovirus can be grown, the ability to escape trapping in the liver upon <i>in vivo</i> systemic delivery, and absence or decreased infection of antigen presenting cells (APC) of the immune system, such as macrophages or dendritic cells. These chimaeric adenoviruses thus represent improved tools for gene therapy and vaccination since they overcome the limitations observed with the currently used serotype subgroup C adenoviruses.</p>		

Title: Chimaeric adenoviruses

The invention relates to the field of molecular genetics and medicine. In particular the present invention relates to the field of gene therapy, more in particular to gene therapy using viruses, especially adenoviruses.

5 In gene therapy, genetic information is delivered to a host cell in order to either correct (supplement) a genetic deficiency in said cell, or to inhibit an unwanted function in said cell, or to eliminate said host cell. Of course the genetic information can also be intended to provide the host  
10 cell with a wanted function, for instance to supply a secreted protein to treat other cells of the host, etc.

Thus there are basically three different approaches in gene therapy, one directed towards compensating a deficiency present in a (mammalian) host; the second directed towards  
15 the removal or elimination of unwanted substances (organisms or cells) and the third towards providing a cell with a wanted function.

For the purpose of gene therapy, adenoviruses have been  
20 proposed as suitable vehicles to deliver genes to the host. Gene-transfer vectors derived from adenoviruses (so-called adenoviral vectors) have a number of features that make them particularly useful for gene transfer. 1) the biology of the adenoviruses is characterized in detail, 2) the adenovirus  
25 is not associated with severe human pathology, 3) the virus is extremely efficient in introducing its DNA into the host cell, 4) the virus can infect a wide variety of cells and has a broad host-range, 5) the virus can be produced at high virus titers in large quantities, and 6) the virus can be  
30 rendered replication defective by deletion of the early-region 1 (E1) of the viral genome (Brody et al, 1994). However, there are still drawbacks associated with the use of adenoviral vectors. Typically adenoviruses, especially the well investigated serotypes usually elicit an immune  
35 response by a host into which they are introduced. Also,

although the virus generally spoken has a wide infection range, there is a problem in targeting certain cells and tissues. Also, the replication and other functions of the adenovirus are not always very well suited for the cells  
5 which are to be provided with the additional genetic material.

The adenovirus genome is a linear double-stranded DNA molecule of approximately 36000 base pairs. The adenovirus  
10 DNA contains identical Inverted Terminal Repeats (ITR) of approximately 90-140 base pairs with the exact length depending on the serotype. The viral origins of replication are within the ITRs exactly at the genome ends.  
Most adenoviral vectors currently used in gene therapy have  
15 a deletion in the E1 region, where novel genetic information can be introduced. The E1 deletion renders the recombinant virus replication defective (Levrero et al, 1991). It has been demonstrated extensively that recombinant adenovirus, in particular serotype 5 is suitable for efficient transfer  
20 of genes *in vivo* to the liver, the airway epithelium and solid tumors in animal models and human xenografts in immunodeficient mice (Bout, 1996; Blaese et al., 1995).  
Thus, preferred methods for *in vivo* gene transfer into target cells make use of adenoviral vectors as gene delivery  
25 vehicles.

At present, six different subgroups of human adenoviruses have been proposed which in total encompasses 51 distinct adenovirus serotypes (see table 1). Besides these human  
30 adenoviruses an extensive number of animal adenoviruses have been identified (see Ishibashi et al, 1983).

A serotype is defined on the basis of its immunological distinctiveness as determined by quantitative neutralization  
35 with animal antisera (horse, rabbit). If neutralization shows a certain degree of cross-reaction between two viruses,

distinctiveness of serotype is assumed if A) the hemagglutinins are unrelated, as shown by lack of cross-reaction on hemagglutination-inhibition, or B) substantial biophysical/ biochemical differences in DNA exist (Francki et al, 1991). The nine serotypes identified last (42-51) were isolated for the first time from HIV- infected patients (Hierholzer et al 1988; Schnurr et al 1993; De Jong et al 1998). For reasons not well understood, most of such immunocompromised patients shed adenoviruses that were rarely or never isolated from immuno-competent individuals (Hierholzer et al 1988, 1992; Khoo et al, 1995, De Jong et al, 1998).

Besides differences towards the sensitivity against neutralizing antibodies of different adenovirus serotypes, it has also been shown that adenoviruses in subgroup C such as Ad2, and Ad5 bind to different receptors as compared to adenoviruses from subgroup B such as Ad3 (Defer et al, 1990). Likewise, it was demonstrated that receptor specificity could be altered by exchanging the Ad3 with the Ad 5 knob protein, and vice versa (Krasnykh et al, 1996; Stevenson et al, 1995, 1997). The adenovirus serotype 5 is most widely used for gene therapy purposes. Similar to serotypes 2, 4 and 7, serotype 5 has a natural affiliation towards lung epithelia and other respiratory tissues. In contrast, it is known that, for instance, serotypes 40 and 41 have a natural affiliation towards the gastrointestinal tract. For a detailed overview of the disease association of the different adenovirus serotypes see table 2. The serotypes described above, differ in at least capsid proteins (penton-base, hexon), proteins responsible for cell binding (fiber protein), and proteins involved in adenovirus replication.

One of the major problems of adenovirus gene therapy is thus that none of the above described serotypes are ideally suitable for delivering additional genetic material to host cells. Some have a somewhat limited host range, but have the

benefit of being less immunogenic, some are the other way round. Some have a problem of being of a limited virulence, but have a broad host range and/or a reduced immunogenicity. To make things even more complicated this variation in the adenovirus serotypes is also very dependent on the host to be treated. Some hosts may already have encountered certain serotypes and thus mount a strong immune response to said serotype or a related serotype. Persons skilled in the art know that there are many other variations on this same theme.

The present invention now makes use of the fact that some adenoviruses have lower immunogenicity than others, which others typically excel in one of the other requirements for an efficient gene therapy regime, such as having a high specificity for a certain group of host cells, a good replication machinery in such host cells, a high rate of infection in certain host cells, etc. The invention thus provides chimaeric adenoviruses having the useful properties of at least two adenoviruses of different serotypes. Typically, more than two requirements from the above non-exhaustive list are required to obtain an adenovirus capable of efficiently transferring additional material to a host cell and therefore the invention provides adenovirus derived vectors which can be used as cassettes to insert different adenoviral genes from different adenoviral serotypes at the required sites for obtaining a vector capable of expressing a chimaeric adenovirus, whereby of course also a gene of interest can be inserted at for instance the site of E1 of the original adenovirus from which the vector is derived. In this manner the chimaeric adenovirus to be produced can be adapted to the requirements and needs of certain hosts in need of gene therapy for certain disorders. Of course to enable this production a packaging cell will generally be needed in order to produce sufficient amount of safe chimaeric adenoviruses.

Thus in one embodiment the invention provides a chimaeric adenovirus comprising at least a part of a fiber protein and/or a protein involved in replication of an adenovirus serotype providing the chimaeric virus with a desired host range and/or improved replication properties and at least a part of a penton or hexon protein from another less antigenic adenovirus serotype resulting in a less antigenic chimaeric adenovirus. Typically such a virus will be produced using a vector (typically a plasmid, a cosmid or baculovirus system which vector is of course also part of the present invention. A preferred vector is a vector which can be used to make a chimaeric recombinant virus specifically adapted to the host to be treated and the disorder to be treated. Such a vector is another embodiment of the present invention. Thus the invention also provides a recombinant vector derived from an adenovirus comprising at least one ITR and a packaging signal, having an insertion site for a nucleic acid sequence of interest, and further having an insertion site for functionally inserting a gene encoding a penton and/or a hexon protein of a first serotype of adenovirus and having an insertion site for a gene encoding a fiber protein of a second adenovirus of a different serotype, and/or an insertion site for a gene derived from a serotype having improved characteristics in the function carried out by that gene or its product. Typically the invention provides cassettes which allow for the production of any desired chimaeric adenovirus, be it only derived from two serotypes or as many as needed to obtain the desired characteristics, whereby it is not always necessary that all characteristics are the best when seen as single properties. It may not even be necessary, for instance, to always alter penton and/or hexon together with another part of adenovirus genes. Sometimes the immunogenicity needs not be altered together with other properties. However, it is preferred to use penton and/or hexon genes from less immunogenic adenovirus serotypes. An important feature of the present invention is

the means to produce the chimaeric virus. Typically, one does not want an adenovirus batch to be administered to the host cell which contains replication competent adenovirus, although this is not always true. In general therefor it is desired to omit a number of genes (but at least one) from the adenoviral genome on the vector encoding the chimaeric virus and to supply these genes in the genome of the cell in which the vector is brought to produce chimaeric adenovirus. Such a cell is usually called a packaging cell. The invention thus also provides a packaging cell for producing a chimaeric adenovirus according to the invention, comprising in trans all elements necessary for adenovirus production not present on the adenoviral vector according to the invention. Typically vector and packaging cell have to be adapted to one another in that they have all the necessary elements, but that they do not have overlapping elements which lead to replication competent virus by recombination. Thus the invention also provides a kit of parts comprising a packaging cell according to the invention and a recombinant vector according the invention whereby there is essentially no sequence overlap leading to recombination resulting in the production of replication competent adenovirus between said cell and said vector.

In order to be able to precisely adapt the viral vector and provide the chimaeric virus with the desired properties at will, it is preferred that a library of adenoviral genes is provided whereby the genes are located within restriction sites. Typically it is preferred to have same kinds of genes of different serotypes within the same restriction sites and to have that same restriction site in the adenoviral vector used to produce the chimaeric virus. If all sites for different genes are unique then a system to pick and choose from has been made. One can cut a penton gene from the desired serotype from the library and insert it at the same site in the vector. One can then use a different restriction enzyme to cut a replication gene from the bank of a different

serotype using another restriction enzyme and insert that gene at the corresponding restriction site in the chimaeric vector. Thus it is to be preferred to have a vector according to the invention where the insertion sites are different and preferably unique restriction sites. Preferably this vector is combined with a library having the corresponding genes within the same restriction sites. Methods to use this library and the vector are within the skill in the art and are part of the present invention. Typically such a method comprises a number of restriction and ligation steps and expression of the result in a packaging cell. Also one can use a library from which the different desired adenoviral genes are obtained through homologous recombination or a combination of restriction and recombination. Thus the invention provides a method for producing a chimaeric adenovirus having a desired host range and diminished antigenicity, comprising providing a vector according to the invention having the desired insertion sites, inserting into said vector at least a functional part of a penton or hexon protein derived from an adenovirus serotype having relatively low antigenicity, inserting at least a functional part of a fiber protein derived from an adenovirus serotype having the desired host range and transfecting said vector in a packaging cell according to the invention and allowing for production of chimaeric viral particles. Of course other combinations of other viral genes originating from different serotypes can also be inserted as disclosed herein before. An immunogenic response to adenovirus that typically occurs is the production of neutralizing antibodies by the host. This is typically a reason for selecting a penton, hexon and/or fiber of a less immunogenic serotype. Of course it may not be necessary to make chimaeric adenoviruses which have complete proteins from different serotypes. It is well within the skill of the art to produce chimaeric proteins, for instance in the case of fiber proteins it is very well possible to have the base of one

serotype and the shaft and the knob from another serotype. In this manner it becomes possible to have the parts of the protein responsible for assembly of viral particles originate from one serotype, thereby enhancing the  
5 production of intact viral particles. Thus the invention also provides a chimaeric adenovirus according to the invention, wherein the hexon, penton and/or fiber proteins are chimaeric proteins originating from different adenovirus serotypes. Besides generating chimaeric adenoviruses by  
10 swapping entire wild type hexon, penton, fiber (protein) genes etc. or parts thereof, it is also within the scope of the present invention to insert hexon, penton, fiber (protein) genes etc. carrying mutations such as point  
15 mutations, deletions, insertions etc. which can be easily screened for preferred characteristics such as temperature stability, assembly, anchoring, redirected infection, altered immune response etc. Again other chimaeric combinations can also be produced and are within the scope of the present invention.

20 The availability of a library of nucleic acids derived from different serotypes allows, among others, the generation of a library of chimaeric adenoviruses. The invention therefore further provides a library of chimaeric adenoviruses. In one  
25 embodiment the invention provides a library of chimaeric adenoviruses wherein said adenoviruses comprise chimaeric capsids, i.e. comprising capsid proteins derived at least in part from at least two different adenovirus serotypes. Preferably, nucleic acid and/or protein or parts thereof, from at least one representative adenovirus of each  
30 adenovirus subgroup is represented in said (chimaeric) adenovirus library. Preferably, nucleic acid and/or protein or parts thereof is derived from more than one representative of each adenovirus subgroup. Most preferably, said library comprises nucleic acid and/or protein or a part  
35 thereof, from essentially every known representative of each adenovirus subgroup. Nucleic acid and/or protein or parts

thereof derived from more than one representative adenovirus from each adenovirus subgroup in said (chimaeric) library is desired because a desirable property may not be a general property of a subgroup. Also, a desirable property of a subgroup of adenovirus may be expressed in different amounts on the various members of the subgroup. Ensuring that more than one representative of a subgroup is represented in the library thus warrants the selection of the best expressor of the desired property.

Typically, a library of chimaeric adenoviruses or a part thereof is used in screening assays to determine properties of said chimaeric adenoviruses. Any particular chimaeric adenovirus comprising particularly desirable properties can thereby be identified and subsequently be used in, for instance, the development of an improved nucleic acid delivery vehicle. Desirable properties said chimaeric adenovirus library may be screened for include, but are not limited to, target cell specificity, reduced immunogenicity, increased immunogenicity, re-directed neutralization, re-directed hemagglutination, improved infection efficiency, reduced toxicity, improved replication and/or improved pharmacokinetics such as altered tissue distribution upon in vivo administration. Comparison of properties of different chimaeric adenoviruses can lead to the delineation of adenovirus elements involved in providing an adenovirus with said property. Such knowledge can then be used to further optimize nucleic acid delivery vehicles. In one aspect the invention provides a selection of (chimaeric) adenoviruses with an improved capacity to transduce macrophage- or fibroblast-like cells compared to adenovirus 5, preferably said (chimaeric) adenoviruses comprise at least part of a tissue tropism determining part of a fiber protein of an adenovirus of subgroup B, or a derivative and/or analogue of said fiber protein. The invention further provides a selection of (chimaeric) adenoviruses with an improved capacity to transduce smooth muscle cells compared to

adenovirus 5, preferably said (chimaeric) adenoviruses comprise at least part of a tissue tropism determining part of a fiber protein of an adenovirus of subgroup B, or a derivative and/or analogue of said fiber protein. A  
5 chimaeric adenovirus library of the invention may further be used to study adenovirus biology. Such a library is for instance very well suited to study differences in the biology of the various adenovirus serotypes. In one aspect the invention provides a selection of (chimaeric)  
10 adenoviruses, capable of transducing a CAR negative cell. Preferably said CAR negative cell is a amnion fluid cell or a derivative thereof. Preferably said amnion fluid cell is a chorion villi cell or a derivative thereof. Preferably said CAR negative cell is a CAR negative hemopoietic cell, such  
15 as but not limited to an erythroid precursor cell and/or a monocyte precursor cell and/or derivatives thereof. Preferably said (chimaeric) adenoviruses capable of transducing a CAR negative cell comprise at least an adenovirus receptor binding part of a fiber protein from an  
20 adenovirus of subgroup D or F.  
In one aspect the invention provides a chimaeric adenovirus comprising a re-directed neutralization pattern compared to adenovirus 5. Re-directed neutralization is useful in a number of circumstances. For instance, but not limited to,  
25 getting round pre-existing neutralizing antibodies in a patient administered with said chimaeric adenovirus. Pre-existing neutralizing antibodies would neutralize the adenovirus and thereby diminish the effective amount of virus administered. This effect is usually not desired in  
30 for instance gene therapy settings wherein a nucleic acid is to be delivered to target cells. However, pre-existing neutralizing antibodies can for instance in other gene therapy applications be an advantage when the nucleic acid of interest delivered through said chimaeric adenovirus  
35 should not be delivered to cells throughout the body. Local delivery for instance by using a needle in a solid tissue

combined with the presence of neutralizing antibodies in the blood that can neutralize leaking chimaeric adenovirus can in that case help to contain the transduction to a certain area.

5 In another aspect the invention provides a chimaeric adenovirus comprising a re-directed hemagglutination pattern compared to adenovirus 5. Re-directed hemagglutination is useful in a number of circumstances. Hemagglutinated material is preferentially taken up by macrophages and  
10 derivatives and/or precursors. Thus enhanced hemagglutination of a chimaeric adenovirus is preferred in case where enhanced delivery of nucleic acid to said macrophages is desired. However, in general the target cell will not be said macrophages thus in those cases a reduced  
15 hemagglutination is desired. A chimaeric adenovirus re-directed in its hemagglutination is useful for many applications which the person skilled art can now think of and thus form an integral part of the present invention.

20 **Detailed description.**

It has been demonstrated in mice that upon *in vivo* systemic delivery of recombinant adenovirus serotype 5 for gene  
25 therapy purposes approximately 99% of the virus is trapped in the liver (Herz et al, 1993). Therefore, alteration of the adenovirus serotype 5 host cell range to be able to target other organs *in vivo* is a major interest of the invention, particularly in combination with other alterations, in particular the immunogenicity.

30 The initial step for successful infection is binding of adenovirus to its target cell, a process mediated through fiber protein. The fiber protein has a trimeric structure (Stouten et al, 1992) with different lengths depending on  
35 the virus serotype (Signas et al 1985; Kidd et all 1993). Different serotypes have polypeptides with structurally

similar N and C termini, but different middle stem regions. N-terminally, the first 30 amino acids are involved in anchoring of the fiber to the penton base (Chroboczek et al, 1995), especially the conserved FNPVYP region in the tail (Arnberg et al 1997). The C-terminus, or knob, is responsible for initial interaction with the cellular adenovirus receptor. After this initial binding secondary binding between the capsid penton base and cell-surface integrins leads to internalization of viral particles in coated pits and endocytosis (Morgan et al, 1969; Svensson et al, 1984; Varga et al, 1992; Greber et al, 1993; Wickham et al, 1994). Integrins are  $\alpha\beta$ -heterodimers of which at least 14  $\alpha$ -subunits and 8  $\beta$ -subunits have been identified (Hynes et al, 1992). The array of integrins expressed in cells is complex and will vary between cell types and cellular environment. Although the knob contains some conserved regions, between serotypes, knob proteins show a high degree of variability, indicating that different adenovirus receptors exist. For instance, it has been demonstrated that adenoviruses of subgroup C (Ad2, Ad5) and adenoviruses of subgroup B (Ad3) bind to different receptors (Defner et al, 1990). The fiber protein also contains the type specific  $\gamma$ -antigen, which together with the  $\epsilon$ -antigen of the hexon determines the serotype specificity. The  $\gamma$ -antigen is localized on the fiber and it is known that it consists of 17 amino acids (Eiz et al, 1997). The anti-fiber antibodies of the host are therefore directed to the trimeric structure of the knob. The anti-fiber antibodies together with antibodies directed against the penton base and hexon proteins are responsible for the neutralization of adenovirus particles. First the anti-fiber antibodies uncoat the adenovirus particles after which the penton base is accessible to the anti-penton base antibodies (Gahery-Segard et al, 1998). Although this seems to be a very effective way to neutralize adenovirus particles others have described

that the anti-hexon antibodies are the most effective ones in neutralization of the particles (Gall et al, 1996).

To obtain re-directed infection of recombinant adenovirus serotype 5, several approaches have been or still are under investigation. Wickham et al has altered the RGD (Arg, Gly, Asp) motif in the penton base which is believed to be responsible for the  $\alpha_v\beta_3$  and  $\alpha_v\beta_5$  integrin binding to the penton base. They have replaced this RGD motif by another peptide motif which is specific for the  $\alpha_4\beta_1$  receptor. In this way targeting the adenovirus to a specific target cell could be accomplished (Wickham et al, 1995, 1996). Krasnykh et al has made use of the HI loop available in the knob. This loop is, based on X-ray crystallographics, located on the outside of the knob trimeric structure and therefore is thought not to contribute to the intramolecular interactions in the knob (Krasnykh et al, 1998). However, complete CAR independent infection was not observed.

It is an object of the present invention to provide a method and means by which adenoviruses can be constructed with an altered immune response, or with the absence or decreased infection in antigen presenting cells such as dendritic cells or macrophages. It is a further object of the present invention to provide methods for the generation of chimaeric adenoviruses as described above which can be targeted to specific cell types *in vitro* as well as *in vivo* have an altered tropism for certain cell types. It is a further object of the present invention to provide a method and means by which such an adenovirus can be used as a protein or nucleic acid delivery vehicle to a specific cell type or tissue.

The generation of chimaeric adenoviruses based on adenovirus serotype 5 with modified late genes is described. For this purpose, three plasmids, which together contain the complete adenovirus serotype 5 genome, were constructed. From these

plasmids the DNA encoding the adenovirus serotype 5 penton-base protein, hexon protein, and fiber protein were removed and replaced by linker DNA sequences which facilitate easy cloning. These plasmids subsequently served as template for the insertion of DNA encoding for penton-base protein, hexon protein, and fiber protein derived from different adenovirus, serotypes (human or animal). The DNAs derived from the different serotypes were obtained using the polymerase chain reaction technique in combination with (degenerate) oligonucleotides. At the former E1 location in the genome of adenovirus serotype 5, any gene of interest can be cloned. A single transfection procedure of the three plasmids together resulted in the formation of a recombinant chimaeric adenovirus. This new technology of libraries consisting of chimaeric adenoviruses thus allows for a rapid screening for improved recombinant adenoviral vectors for *in vitro* and *in vivo* gene therapy purposes.

Although successful introduction of changes in the adenovirus serotype 5 fiber and penton-base have been reported, the complex structure of knob and the limited knowledge of the precise amino acids interacting with CAR render such targeting approaches laborious and difficult. To overcome the limitations described above we used pre-existing adenovirus fibers, penton base proteins, and hexon proteins derived from other adenovirus serotypes. By generating chimaeric adenovirus serotype 5 libraries containing structural proteins of alternative adenovirus serotypes, we have developed a technology which enables rapid screening for a recombinant adenoviral vector with preferred characteristics.

In one aspect this invention describes the use of chimaeric adenoviruses to overcome, natural existing or induced, neutralizing host activity towards recombinant adenoviruses

WO 00/03029

PCT/NL99/00436

15

administered *in vivo* for therapeutic applications. The host immune response is predominantly directed against penton base - and hexon proteins present in the adenoviral capsid and to a lesser extent directed to fiber.

5 The adenovirus serotypes are defined by the inability to cross-react with neutralizing antibodies in animal sera. Therefore chimaeric viruses based on for example adenovirus serotype 5 but chimaeric for penton base protein, and/ or  
10 hexon protein provoke an altered, less severe immune response. The need for such chimaeric adenoviruses is stressed by observations that 1) repeated systemic delivery of recombinant adenovirus serotype 5 is unsuccessful due to formation of high titers of neutralizing antibodies against the recombinant adenovirus serotype 5 (Schulick et al,  
15 1997), and 2) pre-existing or natural immunity. This aspect of the invention therefore circumvents the inability to repeat the administration of an adenovirus for gene therapy purposes. Preferably, the penton base-, hexon-, and fiber proteins are derived from adenoviruses in subgroup  
20 E and D and are more specifically of the adenovirus serotype 16, 24, 33, 36, 38, 39, 42, and 51. This latter is because these serotypes are rarely isolated from humans indicating that low titers of circulating neutralizing antibodies are present against these serotypes.

25 In another aspect this invention describes chimaeric adenoviruses and methods to generate these viruses that have an altered tropism different from that of adenovirus serotype 5. For example, viruses based on adenovirus serotype 5 but displaying any adenovirus fiber existing in  
30 nature. This chimaeric adenovirus serotype 5 is able to infect certain cell types more efficiently, or less efficiently *in vitro* and *in vivo* than the adenovirus serotype 5. Such cells include but are not limited to  
35 endothelial cells, smooth muscle cells, dendritic cells, neuronal cells, glial cells, synovial cells, lung

epithelial cells, hemopoietic stem cells, monocytic/  
macrophage cells etc.

In another aspect this invention describes methods which  
5 identify chimaeric adenoviruses that display improved in  
vitro amplification in static or suspension cell cultures.  
Adenoviruses derived from different subgroups, but also  
within one subgroup, display a high variability in  
productive infection in cell types that are used for  
10 production of recombinant adenovirus. Table 2 lists an  
overview of different adenovirus serotypes and their  
association with human disease, demonstrating that  
replication of a given adenovirus serotype is enhanced in  
certain cell types. For the production of recombinant  
15 adenoviruses for gene therapy purposes, several cell lines  
are available. These include but do not limit PER.C6, 911,  
293, and E1 A549. These adenovirus producer cells may not be  
the most suited cell types to amplify adenovirus serotype 5  
based viruses. Therefore, in this aspect of the invention we  
20 select adenoviruses from different serotypes based on their  
ability to propagate for example on PER.C6 and use their  
early genes (without E1) and ITRs to construct chimaeric  
viruses which are superior in terms of propagation and thus  
yield higher titers as compared to commonly used adenovirus  
25 serotype 2 or 5.

In another aspect the invention describes the construction  
and use of libraries consisting of distinct parts of  
adenovirus serotype 5 in which one or more genes or  
30 sequences have been replaced with DNA derived from  
alternative human or animal serotypes. This set of  
constructs, in total encompassing the complete adenovirus  
genome, allows for the construction of unique chimaeric  
adenoviruses customized for a certain group of patients or  
35 even a single individual.

In all aspects of the invention the chimaeric adenoviruses may, or may not, contain deletions in the E1 region and insertions of heterologous genes linked either or not to a promoter. Furthermore, chimaeric adenoviruses may, or may not, contain deletions in the E3 region and insertions of heterologous genes linked to a promoter. Furthermore, chimaeric adenoviruses may, or may not, contain deletions in the E2 and/ or E4 region and insertions of heterologous genes linked to a promoter. In the latter case E2 and/ or E4 complementing cell lines are required to generate recombinant adenoviruses.

**Example 1: Generation of adenovirus serotype 5 genomic plasmid clones**

The complete genome of adenovirus serotype 5 has been cloned into various plasmids or cosmids to allow easy modification of parts of the adenovirus serotype 5 genome, while still retaining the capability to produce recombinant virus. For this purpose the following plasmids were generated:

1. pBr/Ad.Bam-rITR (ECACC deposit P97082122)

In order to facilitate blunt end cloning of the ITR sequences, wild-type human adenovirus type 5 (Ad5) DNA was treated with Klenow enzyme in the presence of excess dNTPs. After inactivation of the Klenow enzyme and purification by phenol/chloroform extraction followed by ethanol precipitation, the DNA was digested with BamHI. This DNA preparation was used without further purification in a ligation reaction with pBr322 derived vector DNA prepared as follows: pBr322 DNA was digested with EcoRV and BamHI, dephosphorylated by treatment with TSAP enzyme (Life Technologies) and purified on LMP agarose gel (SeaPlaque GTG). After transformation into competent *E.coli* DH5a (Life Techn.) and analysis of ampiciline resistant colonies, one clone was selected that showed a digestion pattern as

expected for an insert extending from the BamHI site in Ad5 to the right ITR.

Sequence analysis of the cloning border at the right ITR revealed that the most 3' G residue of the ITR was missing, the remainder of the ITR was found to be correct. Said  
5 missing G residue is complemented by the other ITR during replication.

2. pBr/Ad.Sal-rITR (ECACC deposit P97082119)

10 pBr/Ad.Bam-rITR was digested with BamHI and SallI. The vector fragment including the adenovirus insert was isolated in LMP agarose (SeaPlaque GTG) and ligated to a 4.8 kb SallI-BamHI fragment obtained from wt Ad5 DNA and purified with the  
15 GeneClean II kit (Bio 101, Inc.). One clone was chosen and the integrity of the Ad5 sequences was determined by restriction enzyme analysis. Clone pBr/Ad.Sal-rITR contains adeno type 5 sequences from the SallI site at bp 16746 up to and including the rITR (missing the most 3' G residue).

3. pBr/Ad.Cla-Bam (ECACC deposit P97082117)

20 wt Adeno type 5 DNA was digested with ClaI and BamHI, and the 20.6 kb fragment was isolated from gel by electro-elution. pBr322 was digested with the same enzymes and purified from agarose gel by GeneClean. Both fragments were ligated and  
25 transformed into competent DH5a. The resulting clone pBr/Ad.Cla-Bam was analyzed by restriction enzyme digestion and shown to contain an insert with adenovirus sequences from bp 919 to 21566.

4. pBr/Ad.AflIII-Bam (ECACC deposit P97082114)

30 Clone pBr/Ad.Cla-Bam was linearized with EcoRI (in pBr322) and partially digested with AflIII. After heat inactivation of AflIII for 20' at 65°C the fragment ends were filled in with Klenow enzyme. The DNA was then ligated to a blunt double  
35 stranded oligo linker containing a PacI site (5'-AATTGTCTTAATTAACCGCTTAA-3'). This linker was made by

annealing the following two oligonucleotides: 5'-AATTGTCTTAATTAACCGC-3' and 5'-AATTGCGGTTAATTAAGAC-3', followed by blunting with Klenow enzyme. After precipitation of the ligated DNA to change buffer, the ligations were digested with an excess PacI enzyme to remove concatamers of the oligo. The 22016 bp partial fragment containing Ad5 sequences from bp 3534 up to 21566 and the vector sequences, was isolated in LMP agarose (SeaPlaque GTG), religated and transformed into competent DH5a. One clone that was found to contain the PacI site and that had retained the large adeno fragment was selected and sequenced at the 5' end to verify correct insertion of the PacI linker in the (lost) AflIII site.

15 5. pBr/Ad.Bam-rITRpac#2 (ECACC deposit P97082120) and pBr/Ad.Bam-rITR#8 (ECACC deposit P97082121)  
To allow insertion of a PacI site near the ITR of Ad5 in clone pBr/Ad.Bam-rITR about 190 nucleotides were removed between the ClaI site in the pBr322 backbone and the start of the ITR sequences. This was done as follows: pBr/Ad.Bam-rITR was digested with ClaI and treated with nuclease Bal31 for varying lengths of time (2', 5', 10' and 15'). The extent of nucleotide removal was followed by separate reactions on pBr322 DNA (also digested at the ClaI site), using identical buffers and conditions. Bal31 enzyme was inactivated by incubation at 75°C for 10 minutes, the DNA was precipitated and resuspended in a smaller volume of TE buffer. To ensure blunt ends, DNAs were further treated with T4 DNA polymerase in the presence of excess dNTPs. After digestion of the (control) pBr322 DNA with SalI, satisfactory degradation (~150 bp) was observed in the samples treated for 10' or 15'. The 10' or 15' treated pBr/Ad.Bam-rITR samples were then ligated to the above described blunted PacI linkers (See pBr/Ad.AflIII-Bam). Ligations were purified by precipitation, digested with excess PacI and separated from the linkers on an LMP agarose gel. After religation, DNAs were transformed

into competent DH5a and colonies analyzed. Ten clones were selected that showed a deletion of approximately the desired length and these were further analyzed by T-track sequencing (T7 sequencing kit, Pharmacia Biotech). Two clones were found with the PacI linker inserted just downstream of the rITR. After digestion with PacI, clone #2 has 28 bp and clone #8 has 27 bp attached to the ITR.

pWE/Ad.AflIII-rITR (ECACC deposit P97082116)

Cosmid vector pWE15 (Clontech) was used to clone larger Ad5 inserts. First, a linker containing a unique PacI site was inserted in the EcoRI sites of pWE15 creating pWE.pac. To this end, the double stranded PacI oligo as described for pBr/Ad.AflIII-BamHI was used but now with its EcoRI protruding ends. The following fragments were then isolated by electro-elution from agarose gel: pWE.pac digested with PacI, pBr/AflIII-Bam digested with PacI and BamHI and pBr/Ad.Bam-rITR#2 digested with BamHI and PacI. These fragments were ligated together and packaged using 1 phage packaging extracts (Stratagene) according to the manufacturer's protocol. After infection into host bacteria, colonies were grown on plates and analyzed for presence of the complete insert. pWE/Ad.AflIII-rITR contains all adenovirus type 5 sequences from bp 3534 (AflIII site) up to and including the right ITR (missing the most 3' G residue).

pBr/Ad.lITR-Sal(9.4) (ECACC deposit P97082115)

Adeno 5 wt DNA was treated with Klenow enzyme in the presence of excess dNTPs and subsequently digested with SalI. Two of the resulting fragments, designated left ITR-Sal(9.4) and Sal(16.7)-right ITR, respectively, were isolated in LMP agarose (Seaplaque GTG). pBr322 DNA was digested with EcoRV and SalI and treated with phosphatase (Life Technologies). The vector fragment was isolated using the GeneClean method (BIO 101, Inc.) and ligated to the Ad5 SalI fragments. Only the ligation with the 9.4 kb fragment gave colonies with an

insert. After analysis and sequencing of the cloning border a clone was chosen that contained the full ITR sequence and extended to the SalI site at bp 9462.

- 5 pBr/Ad.lITR-Sal(16.7) (ECACC deposit P97082118)  
pBr/Ad.lITR-Sal(9.4) is digested with SalI and dephosphorylated (TSAP, Life Technologies). To extend this clone upto the third SalI site in Ad5, pBr/Ad.Cla-Bam was linearized with BamHI and partially digested with SalI. A 7.3  
10 kb SalI fragment containing adenovirus sequences from 9462-16746 was isolated in LMP agarose gel and ligated to the SalI-digested pBr/Ad.lITR-Sal(9.4) vector fragment.

- pWE/Ad.AflIII-EcoRI  
15 pWE.pac was digested with ClaI and 5' protruding ends were filled using Klenow enzyme. The DNA was then digested with PacI and isolated from agarose gel. pWE/AflIII-rITR was digested with EcoRI and after treatment with Klenow enzyme digested with PacI. The large 24 kb fragment containing the  
20 adenoviral sequences was isolated from agarose gel and ligated to the ClaI-digested and blunted pWE.pac vector using the Ligation Express<sup>™</sup> kit from Clontech. After transformation of Ultracompetent XL10-Gold cells from Stratagene, clones were identified that contained the  
25 expected insert. pWE/AflIII-EcoRI contains Ad5 sequences from bp 3534-27336.

#### Construction of new adapter plasmids

- The absence of sequence overlap between the recombinant  
30 adenovirus and E1 sequences in the packaging cell line is essential for safe, RCA-free generation and propagation of new recombinant viruses. The adapter plasmid pMLPI.TK (figure. 1) is an example of an adapter plasmid designed for use according to the invention in combination with the  
35 improved packaging cell lines of the invention. This plasmid was used as the starting material to make a new vector in

which nucleic acid molecules comprising specific promoter and gene sequences can be easily exchanged.

First, a PCR fragment was generated from pZipΔMo+PyF101(N<sup>-</sup>) template DNA (described in PCT/NL96/00195) with the following primers: LTR-1: 5'-CTG TAC GTA CCA GTG CAC TGG CCT AGG CAT GGA AAA ATA CAT AAC TG-3' and LTR-2: 5'-GCG GAT CCT TCG AAC CAT GGT AAG CTT GGT ACC GCT AGC GTT AAC CGG GCG ACT CAG TCA ATC G-3'. Pwo DNA polymerase (Boehringer Mannheim) was used according to manufacturers protocol with the following temperature cycles: once 5' at 95°C; 3' at 55°C; and 1' at 72°C, and 30 cycles of 1' at 95°C, 1' at 60°C, 1' at 72°C, followed by once 10' at 72°C. The PCR product was then digested with BamHI and ligated into pMLP10 (Levrero et al., 1991) vector digested with PvuII and BamHI, thereby generating vector pLTR10. This vector contains adenoviral sequences from bp 1 up to bp 454 followed by a promoter consisting of a part of the Mo-MuLV LTR having its wild-type enhancer sequences replaced by the enhancer from a mutant polyoma virus (PyF101). The promoter fragment was designated L420. Next, the coding region of the murine HSA gene was inserted. pLTR10 was digested with BstBI followed by Klenow treatment and digestion with NcoI. The HSA gene was obtained by PCR amplification on pUC18-HSA (Kay et al., 1990) using the following primers: HSA1, 5'-GCG CCA CCA TGG GCA GAG CGA TGG TGG C-3' and HSA2, 5'-GTT AGA TCT AAG CTT GTC GAC ATC GAT CTA CTA ACA GTA GAG ATG TAG AA-3'. The 269 bp amplified fragment was subcloned in a shuttle vector using the NcoI and BglII sites. Sequencing confirmed incorporation of the correct coding sequence of the HSA gene, but with an extra TAG insertion directly following the TAG stop codon. The coding region of the HSA gene, including the TAG duplication was then excised as a NcoI (sticky)-SalI (blunt) fragment and cloned into the 3.5 kb NcoI(sticky)/BstBI(blunt) fragment from pLTR10, resulting in pLTR-HSA10.

Finally, pLTR-HSA10 was digested with EcoRI and BamHI after which the fragment containing the left ITR, packaging signal,

L420 promoter and HSA gene was inserted into vector pMLPI.TK digested with the same enzymes and thereby replacing the promoter and gene sequences. This resulted in the new adapter plasmid pAd/L420-HSA (figure. 2) that contains convenient  
5 recognition sites for various restriction enzymes around the promoter and gene sequences. SnaBI and AvrII can be combined with HpaI, NheI, KpnI, HindIII to exchange promoter sequences, while the latter sites can be combined with the ClaI or BamHI sites 3' from HSA coding region to replace  
10 genes in this construct. Another adapter plasmid that was designed to allow easy exchange of nucleic acid molecules was made by replacing the promoter, gene and poly A sequences in pAd/L420-HSA with the CMV promoter, a multiple cloning site, an intron and a poly-A  
15 signal. For this purpose, pAd/L420-HSA was digested with AvrII and BglII followed by treatment with Klenow to obtain blunt ends. The 5.1 kb fragment with pBr322 vector and adenoviral sequences was isolated and ligated to a blunt 1570 bp fragment from pcDNA1/amp (Invitrogen) obtained by  
20 digestion with HhaI and AvrII followed by treatment with T4 DNA polymerase. This adapter plasmid was named pCLIP.Luc (figure. 3).

#### Generation of recombinant adenoviruses

25 To generate E1 deleted recombinant adenoviruses with the new plasmid-based system, the following constructs are prepared:  
a) An adapter construct containing the expression cassette with the gene of interest linearized with a restriction  
30 enzyme that cuts at the 3' side of the overlapping adenoviral genome fragment, preferably not containing any pBr322 vector sequences, and  
b) A complementing adenoviral genome construct pWE/Ad.AflIII-rITR digested with PacI.  
35 These two DNA molecules are further purified by phenol/chloroform extraction and EtOH precipitation. Co-transfection

of these plasmids into an adenovirus packaging cell line, preferably a cell line according to the invention, generates recombinant replication deficient adenoviruses by a one-step homologous recombination between the adapter and the complementing construct (figure. 4).

Alternatively, in stead of pWE/Ad.AflIII-rITR other fragments can be used, e.g., pBr/Ad.Cla-Bam digested with EcoRI and BamHI or pBr/Ad.AflIII-BamHI digested with PacI and BamHI can be combined with pBr/Ad.Sal-rITR digested with SalI. In this case, three plasmids are combined and two homologous recombinations are needed to obtain a recombinant adenovirus (figure. 5). It is to be understood that those skilled in the art may use other combinations of adapter and complementing plasmids without departing from the present invention.

A general protocol as outlined below and meant as a non-limiting example of the present invention has been performed to produce several recombinant adenoviruses using various adapter plasmids and the Ad.AflIII-rITR fragment. Adenovirus packaging cells (PER.C6) were seeded in ~25 cm<sup>2</sup> flasks and the next day when they were at ~80% confluency, transfected with a mixture of DNA and lipofectamine agent (Life Techn.) as described by the manufacturer. Routinely, 40 µl lipofectamine, 4 µg adapter plasmid and 4 µg of the complementing adenovirus genome fragment AflIII- rITR (or 2 µg of all three plasmids for the double homologous recombination) are used. Under these conditions transient transfection efficiencies of ~50% (48 hrs post transfection) are obtained as determined with control transfections using a pAd/CMV-LacZ adapter. Two days later, cells are passaged to ~80 cm<sup>2</sup> flasks and further cultured. Approximately five (for the single homologous recombination) to eleven days (for the double homologous recombination) later a cytopathogenic effect (CPE) is seen, indicating that functional adenovirus has formed. Cells and medium are harvested upon full CPE and recombinant virus is released by freeze-thawing. An extra

amplification step in an 80 cm<sup>2</sup> flask is routinely performed to increase the yield since at the initial stage the titers are found to be variable despite the occurrence of full CPE. After amplification, viruses are harvested and plaque  
5 purified on PER.C6 cells. Individual plaques are tested for viruses with active transgenes.

Besides replacements in the E1 region it is possible to delete or replace (part of) the E3 region in the adenovirus  
10 because E3 functions are not necessary for the replication, packaging and infection of the (recombinant) virus. This creates the opportunity to use a larger insert or to insert more than one gene without exceeding the maximum package size (approximately 105% of wt genome length). This can be done,  
15 e.g., by deleting part of the E3 region in the pBr/Ad.Bam-rITR clone by digestion with XbaI and religation. This removes Ad5 wt sequences 28592-30470 including all known E3 coding regions. Another example is the precise replacement of the coding region of gp19K in the E3 region with a polylinker  
20 allowing insertion of new sequences. This, 1) leaves all other coding regions intact and 2) obviates the need for a heterologous promoter since the transgene is driven by the E3 promoter and pA sequences, leaving more space for coding sequences.

25 To this end, the 2.7 kb EcoRI fragment from wt Ad5 containing the 5' part of the E3 region was cloned into the EcoRI site of pBluescript (KS<sup>-</sup>) (Stratagene). Next, the HindIII site in the polylinker was removed by digestion with EcoRV and HincII and subsequent religation. The resulting clone pBS.Eco-  
30 Eco/ad5DHIII was used to delete the gp19K coding region. Primers 1 (5'-GGG TAT TAG GCC AA AGG CGC A-3') and 2 (5'-GAT CCC ATG GAA GCT TGG GTG GCG ACC CCA GCG-3') were used to amplify a sequence from pBS.Eco-Eco/Ad5DHIII corresponding to  
35 sequences 28511 to 28734 in wt Ad5 DNA. Primers 3 (5'-GAT CCC ATG GGG ATC CTT TAC TAA GTT ACA AAG CTA-3') and 4 (5'-GTC GCT GTA GTT GGA CTG G-3') were used on the same DNA to amplify

Ad5 sequences from 29217 to 29476. The two resulting PCR fragments were ligated together by virtue of the new introduced NcoI site and subsequently digested with XbaI and MunI. This fragment was then ligated into the pBS.Eco-Eco/ad5  
5 ΔHIII vector that was digested with XbaI (partially) and MunI generating pBS.Eco-Eco/ad5ΔHIII.Agp19K. To allow insertion of foreign genes into the HindIII and BamHI site, an XbaI deletion was made in pBS.Eco-Eco/ad5ΔHIII.Agp19K to remove the BamHI site in the Bluescript polylinker. The resulting  
10 plasmid pBS.Eco-Eco/ad5ΔHIII.Agp19KΔXbaI, contains unique HindIII and BamHI sites corresponding to sequences 28733 (HindIII) and 29218 (BamHI) in Ad5. After introduction of a foreign gene into these sites, either the deleted XbaI fragment is re-introduced, or the insert is recloned into  
15 pBS.Eco-Eco/ad5ΔHIII.Agp19K using HindIII and for example MunI. Using this procedure, we have generated plasmids expressing HSV-TK, hIL-1a, rat IL-3, luciferase or LacZ. The unique SrfI and NotI sites in the pBS.Eco-Eco/ad5ΔHIII.Agp19K plasmid (with or without inserted gene of interest) are used  
20 to transfer the region comprising the gene of interest into the corresponding region of pBr/Ad.Bam-rITR, yielding construct pBr/Ad.Bam-rITR.Agp19K (with or without inserted gene of interest). This construct is used as described *supra* to produce recombinant adenoviruses. In the viral context,  
25 expression of inserted genes is driven by the adenovirus E3 promoter.

Recombinant viruses that are both E1 and E3 deleted are generated by a double homologous recombination procedure as described above for E1-replacement vectors using a plasmid-  
30 based system consisting of:

- a) an adapter plasmid for E1 replacement according to the invention, with or without insertion of a first gene of interest,
- b) the pWE/Ad.AflIII-EcoRI fragment, and
- 35 c) the pBr/Ad.Bam-rITR.Agp19K plasmid with or without insertion of a second gene of interest.

In addition to manipulations in the E3 region, changes of (parts of) the E4 region can be accomplished easily in pBr/Ad.Bam-rITR. Generation and propagation of such a virus, however, in some cases demands complementation in trans.

5

**Example 2: Generation of adenovirus serotype 5 based viruses with chimaeric fiber proteins**

The method described *infra* to generate recombinant adenoviruses by co-transfection of two, or more separate cloned adenoviral sequences. These cloned adenoviral sequences were subsequently used to remove specific adenovirus serotype 5 sequences in order to generate template clones which allow for the easy introduction of DNA sequences derived from other adenovirus serotypes. As an example of these template clones, the construction of plasmids enabling swapping of DNA encoding for fiber protein is given below.

Generation of adenovirus template clones lacking DNA encoding fiber

The fiber coding sequence of adenovirus serotype 5 is located between nucleotides 31042 and 32787. To remove the adenovirus serotype 5 DNA encoding fiber we started with construct pBr/Ad.Bam-rITR. First a NdeI site was removed from this construct. For this purpose, pBr322 plasmid DNA was digested with NdeI after which protruding ends were filled using Klenow enzyme. This pBr322 plasmid was then re-ligated, digested with NdeI and transformed into *E.coli* DH5 $\alpha$ . The obtained pBr/ $\Delta$ NdeI plasmid was digested with ScaI and SalI and the resulting 3198 bp vector fragment was ligated to the 15349 bp ScaI-SalI fragment derived from pBr/Ad.BamrITR, resulting in plasmid pBr/Ad.Bam-rITR $\Delta$ NdeI which hence contained a unique NdeI site. Next a PCR was performed with oligonucleotides NY-up: 5'- CGA CAT ATG TAG ATG CAT TAG TTT  
GTG TTA TGT TTC AAC GTG-3'

And NY-down:5'-GGA GAC CAC TGC CAT GTT-3' (figure 6). During amplification, both a NdeI (bold face) and a NsiI restriction site (underlined) were introduced to facilitate cloning of the amplified fiber DNAs. Amplification consisted of 25 cycles of each 45 sec. at 94°C, 1 min. at 60°C, and 45 sec. at 72°C. The PCR reaction contained 25 pmol of oligonucleotides NY-up or NY-down, 2mM dNTP, PCR buffer with 1.5 mM MgCl<sub>2</sub>, and 1 unit of Elongase heat stable polymerase (Gibco, The Netherlands). One-tenth of the PCR product was run on an agarose gel which demonstrated that the expected DNA fragment of ± 2200 bp was amplified. This PCR fragment was subsequently purified using GeneClean kit system (Bio101 Inc.). Then, both the construct pBr/Ad.Bam-rITRANdeI as well as the PCR product were digested with restriction enzymes NdeI and SbfI. The PCR fragment was subsequently cloned using T4 ligase enzyme into the NdeI and SbfI digested pBr/Ad.Bam-rITRANdeI, generating pBr/Ad.BamRAFib. This plasmid allows insertion of any PCR amplified fiber sequence through the unique NdeI and NsiI sites that are inserted in place of the removed fiber sequence. Viruses can be generated by a double homologous recombination in packaging cells described *infra* using an adapter plasmid, construct pBr/Ad.AflII-EcoRI digested with PacI and EcoRI and a pBr/Ad.BamRAFib construct in which heterologous fiber sequences have been inserted. To increase the efficiency of virus generation, the construct pBr/Ad.BamRAFib was modified to generate a PacI site flanking the right ITR. Hereto, pBr/Ad.BamRAFib was digested with AvrII and the 5 kb adeno fragment was isolated and introduced into the vector pBr/Ad.Bam-rITR.pac#8 replacing the corresponding AvrII fragment. The resulting construct was named pBr/Ad.BamRAFib.pac. Once a heterologous fiber sequence is introduced in pBr/Ad.BamRAFib.pac, the fiber modified right hand adenovirus clone may be introduced into a large cosmid clone as described for pWE/Ad.AflII-rITR in example 1. Such a large cosmid clone allows generation of adenovirus by

only one homologous recombination making the process extremely efficient.

Amplification of fiber sequences from adenovirus serotypes

- 5 To enable amplification of the DNAs encoding fiber protein derived from alternative serotypes degenerate oligonucleotides were synthesized. For this purpose, first known DNA sequences encoding fiber protein of alternative serotypes were aligned to identify conserved regions in both
- 10 the tail-region as well as the knob-region of the fiber protein. From the alignment, which contained the nucleotide sequence of 19 different serotypes representing all 6 subgroups, (degenerate) oligonucleotides were synthesized (see table 3). Also shown in table 3 is the combination of
- 15 oligonucleotides used to amplify the DNA encoding fiber protein of a specific serotype. The amplification reaction (50 µl) contained 2 mM dNTPs, 25 pmol of each oligonucleotide, standard 1x PCR buffer, 1,5 mM MgCl<sub>2</sub>, and 1 Unit Pwo heat stable polymerase (Boehringer) per reaction.
- 20 The cycler program contained 20 cycles, each consisting of 30 sec. 94°C, 60 sec. 60-64°C, and 120 sec. at 72°C. One-tenth of the PCR product was run on an agarose gel which demonstrated that a DNA fragment was amplified. Of each different
- 25 template, two independent PCR reactions were performed after which the independent PCR fragments obtained were sequenced to determine the nucleotide sequence. From 11 different serotypes, the nucleotide sequence could be compared to sequences present in GenBank. Of all other serotypes, the DNA encoding fiber protein was unknown till date and was
- 30 therefore aligned with known sequences from other subgroup members to determine homology i.e. sequence divergence. Of the 51 human serotypes known to date, all fiber sequences, except for serotypes 1, 6, and 26, have been amplified and sequenced. The protein sequences of the fiber from different
- 35 adenovirus serotypes is given in figure 7.

Generation of fiber chimaeric adenoviral DNA constructs

All amplified fiber DNAs as well as the vector (pBr/Ad.BamRA Fib) were digested with NdeI and NsiI. The digested DNAs was  
5 subsequently run on a agarose gel after which the fragments were isolated from the gel and purified using the GeneClean kit (Bio101 Inc). The PCR fragments were then cloned into the NdeI and NsiI sites of pBr/AdBamRAFib, thus generating pBr/AdBamRFibXX (where XX stands for the serotype number of  
10 which the fiber DNA was isolated). So far the fiber sequence of serotypes 5/ 7/ 8/ 9/ 10/ 11/ 12/ 13/ 14/ 16/ 17/ 19/ 21/ 24/ 27/ 28/ 29/ 30/ 32/ 33/ 34/ 35/ 36/ 37/ 38/ 40-S/ 40-L/ 41-S/ 42/45/ 47/ 49/ 51 have been cloned into pBr/AdBamRFibXX. From pBr/AdBamRFibXX (where XX is 5/ 8/ 9/  
15 10/ 11/ 13/ 16/ 17/ 24/ 27/ 30/ 32/ 33/ 34/ 35/ 38/ 40-S/ 40-L/ 45/ 47/ 49/ 51) an 6 kb AvrII fragment encompassing the fiber sequence was isolated via gelelectrophoresis and GeneClean. This AvrII fragment was subsequently cloned in plasmid pBr/Ad.Bam-rITR.pac (see example 1) which was  
20 digested to completion with AvrII and dephosphorylated as described previously, leading to the generation of the plasmid pBr/Ad.Bam-rITR.pac.fibXX. This plasmid was subsequently used to generate a cosmid clone with a modified fiber using the constructs pWE.pac, pBr/AflIII-Bam and  
25 pBr/Ad.Bam-rITR.pac.fibXX. This cosmid cloning resulted in the formation of construct pWE/Ad.AflIII-rITR/FibXX (where XX stands for the serotype number of which the fiber DNA was isolated).

**30 Generation of pAd5/L420.HSA, pAd5/Clip and pAd5/Clipsal**

pMLPI.TK was used to make a new vector in which nucleic acid molecules comprising specific promoter and gene sequences can be easily exchanged.

First, a PCR fragment was generated from pZipAMo+PyF101(N')  
35 template DNA (described in PCT/NL96/00195) with the following primers: LTR-1: 5'-CTG TAC GTA CCA GTG CAC TGG CCT AGG CAT

GGA AAA ATA CAT AAC TG-3' and LTR-2: 5'-GCG GAT CCT TCG AAC  
CAT GGT AAG CTT GGT ACC GCT AGC GTT AAC CGG GCG ACT CAG TCA  
ATC G-3'. Pwo DNA polymerase (Boehringer Mannheim) was used  
according to manufacturers protocol with the following  
5 temperature cycles: once 5' at 95°C; 3' at 55°C; and 1' at  
72°C, and 30 cycles of 1' at 95°C, 1' at 60°C, 1' at 72°C,  
followed by once 10' at 72°C. The PCR product was then  
digested with BamHI and ligated into pMLP10 (Levrero et al.,  
1991; Gene 101, 195-202) digested with PvuII and BamHI,  
10 thereby generating vector pLTR10. This vector contains  
adenoviral sequences from bp 1 up to bp 454 followed by a  
promoter consisting of a part of the Mo-MuLV LTR having its  
wild-type enhancer sequences replaced by the enhancer from a  
mutant polyoma virus (PyF101). The promoter fragment was  
15 designated L420. Sequencing confirmed correct amplification  
of the LTR fragment however the most 5' bases in the PCR  
fragment were missing so that the PvuII site was not  
restored. Next, the coding region of the murine HSA gene was  
inserted. pLTR10 was digested with BstBI followed by Klenow  
20 treatment and digestion with NcoI. The HSA gene was obtained  
by PCR amplification on pUC18-HSA (Kay et al., 1990; J.  
Immunol. 145, 1952-1959) using the following primers: HSA1,  
5'-GCG CCA CCA TGG GCA GAG CGA TGG TGG C-3' and HSA2, 5'-GTT  
AGA TCT AAG CTT GTC GAC ATC GAT CTA CTA ACA GTA GAG ATG TAG  
25 AA-3'. The 269 bp amplified fragment was subcloned in a  
shuttle vector using the NcoI and BglIII sites. Sequencing  
confirmed incorporation of the correct coding sequence of the  
HSA gene, but with an extra TAG insertion directly following  
the TAG stop codon. The coding region of the HSA gene,  
30 including the TAG duplication was then excised as a  
NcoI(sticky)-SalI(blunt) fragment and cloned into the 3.5 kb  
NcoI(sticky)/BstBI(blunt) fragment from pLTR10, resulting in  
pLTR-HSA10.  
Finally, pLTR-HSA10 was digested with EcoRI and BamHI after  
35 which the fragment containing the left ITR, packaging signal,  
L420 promoter and HSA gene was inserted into vector pMLP1.TK

digested with the same enzymes and thereby replacing the promoter and gene sequences. This resulted in the new adapter plasmid pAd5/L420-HSA that contains convenient recognition sites for various restriction enzymes around the promoter and gene sequences. *Sna*BI and *Avr*II can be combined with *Hpa*I, *Nhe*I, *Kpn*I, *Hind*III to exchange promoter sequences, while the latter sites can be combined with the *Cla*I or *Bam*HI sites 3' from HSA coding region to replace genes in this construct.

Another adapter plasmid that was designed to allow easy exchange of nucleic acid molecules was made by replacing the promoter, gene and polyA sequences in pAd5/L420-HSA with the CMV promoter, a multiple cloning site, an intron and a polyA signal. For this purpose, pAd5/L420-HSA was digested with *Avr*II and *Bgl*II followed by treatment with Klenow to obtain blunt ends. The 5.1 kb fragment with pBr322 vector and adenoviral sequences was isolated and ligated to a blunt 1570 bp fragment from pcDNA1/amp (Invitrogen) obtained by digestion with *Hha*I and *Avr*II followed by treatment with T4 DNA polymerase. This adapter plasmid was named pAd5/Clip. To enable removal of vector sequences from the adenoviral fragment pAd5/Clip was partially digested with *Eco*RI and the linear fragment was isolated. An oligo of the sequence 5' TTAAGTCGAC-3' was annealed to itself resulting in a linker with a *Sal*I site and *Eco*RI overhang. The linker was ligated to the partially digested pAd5/Clip vector and clones were selected that had the linker inserted in the *Eco*RI site 23 bp upstream of the left adenovirus ITR in pAd5/Clip resulting in pAd5/Clipsal.

30 Generation of pAd5ClipLacZ, pAd5Clip.Luc, pAd5Clip.TK and pAd5Clipsal.Luc

The adapter plasmid pAd5/Clip.LacZ was generated as follows: The *E. coli* LacZ gene was amplified from the plasmid pMLP.nlsLacZ (EP 95-202 213) by PCR with the primers  
35 5'GGGGTGGCCAGGGTACCTCTAGGCTTTTGCAA and  
5'GGGGGATCCATAAACAAGTTCAGAATCC. The PCR reaction was

performed Ex Taq (Takara) according to the suppliers protocol at the following amplification program: 5 minutes 94°C, 1 cycle; 45 seconds 94°C and 30 seconds 60°C and 2 minutes 72°C, 5 cycles; 45 seconds 94°C and 30 seconds 65°C  
5 and 2 minutes 72°C, 25 cycles; 10 minutes 72; 45 seconds 94°C and 30 seconds 60°C and 2 minutes 72°C, 5 cycles, 1 cycle.  
The PCR product was subsequently digested with KpnI and BamHI and the digested DNA fragment was ligated into  
10 KpnI/BamHI digested pcDNA3 (Invitrogen), giving rise to pcDNA3.nlsLacZ. Next, the plasmid pAd5/Clip was digested with SpeI. The large fragment containing part of the 5' part CMV promoter and the adenoviral sequences was isolated. The plasmid pcDNA3.nlsLacZ was digested with SpeI and the  
15 fragment containing the 3' part of the CMV promoter and the lacZ gene was isolated. Subsequently, the fragments were ligated, giving rise to pAd/Clip.LacZ. The reconstitution of the CMV promoter was confirmed by restriction digestion.

The adapter plasmid pAd5/Clip.Luc was generated as  
20 follows: The plasmid pCMV.Luc (EP 95-202 213) was digested with HindIII and BamHI. The DNA fragment containing the luciferase gene was isolated. The adapter plasmid pAd5/Clip was digested with HindIII and BamHI, and the large fragment was isolated. Next, the isolated DNA fragments were ligated,  
25 giving rise to pAd5/Clip.Luc. The adapter pClipsal.Luc was generated in the same way but using the adapter pClipsal digested with HIII and BamHI as vector fragment. Likewise, the TK containing HIII-BamHI fragment from pCMV.TK (EP 95-202 213) was inserted in pClipsal to generate pAd5/Clip.TK.  
30 The presence of the Sall site just upstream of the left ITR enables liberation of vector sequences from the adeno insert. Removal of these vector sequences enhances frequency of vector generation during homologous recombination in  
35 PER.C6.

Generation of recombinant adenovirus chimaeric for fiber protein

To generate recombinant Ad 5 virus carrying the fiber of serotype 12, 16, 28, 40-L, 51, and 5, three constructs, pCLIP.Luc, pWE/AdAflIII-Eco and pBr/AdBamrITR.pac/fibXX (XX = 12, 16, 28, 40-L, 51, and 5) were transfected into adenovirus producer cells. To generate recombinant Ad 5 virus carrying the fiber of 5/ 7/ 8/ 9/ 10/ 11/ 12/ 13/ 14/ 16/ 17/ 19/ 21/ 24/ 27/ 28/ 29/ 30/ 32/ 33/ 34/ 35/ 36/ 37/ 38/ 40-S/ 40-L/ 41-S/ 42/45/ 47/ 49/ 51, two constructs pCLIP.Luc and pWE/Ad.AflIII-rITR/FibXX were transfected into adenovirus producer cells.

For transfection, 2 µg of pCLIP.Luc, and 4 µg of both pWE/AdAflIII-Eco and pBr/AdBamrITR.pac/fibXX (or in case of cosmid: 4 µg of pCLIP.Luc plus 4 µg of pWE/Ad.AflIII-rITR/FibXX) were diluted in serum free DMEM to 100 µl total volume. To this DNA suspension 100 µl 1x diluted lipofectamine (Gibco) was added. After 30 minutes at room temperature the DNA-lipofectamine complex solution was added to 2.5 ml of serum-free DMEM which was subsequently added to a T25 cm<sup>2</sup> tissue culture flask. This flask contained 2x10<sup>6</sup> PER.C6 cells that were seeded 24-hours prior to transfection. Two hours later, the DNA-lipofectamine complex containing medium was diluted once by the addition of 2.4 ml DMEM supplemented with 20% fetal calf serum. Again 24 hours later the medium was replaced by fresh DMEM supplemented with 10% fetal calf serum. Cells were cultured for 6-8 days, subsequently harvested, and freeze/thawed 3 times. Cellular debris was removed by centrifugation for 5 minutes at 3000 rpm room temperature. Of the supernatant (12.5 ml) 3-5 ml was used to infect again infect PER.C6 cells (T80 cm<sup>2</sup> tissue culture flasks). This re-infection results in full cytopathogenic effect (CPE) after 5-6 days after which the adenovirus is harvested as described above. With the generated virus batch two assays were routinely performed. 1)

20 µl virus supernatant, diluted 10-fold by the addition of 1980 µl DMEM was used to infect A549 cells that were seeded 24-hours prior to infection at a concentration of  $10^5$  cells per well of 6-well plates. Forthly-eight hours later protein lysates were prepared that were subsequently used to measure marker gene expression (luciferase activity). 2) 20 µl virus supernatant is used to determine the virus titer on human 911 cells. For this purpose, 911 cells are seeded at a concentration of  $4 \times 10^4$  cells per well in 96-well plates. Three to four hours after seeding, the medium was replaced by adenovirus supernatant (dilution range: 2 µl -  $5 \times 10^{-9}$  µl). The virus titers of the chimaeric fiber adenovirus serotype 5 always exceeded  $1 \times 10^8$  infectious units per ml.

15 **Example 3: Production, purification, and titration of chimaeric adenoviruses**

Of the supernatant obtained from transfected PER.C6 cells typically 10 ml was used to inoculate a 1 liter fermentor which contained 1 -  $1.5 \times 10^6$  cells/ ml PER.C6 that were specifically adapted to grow in suspension. Three days after inoculation, the cells were harvested and pelleted by centrifugating for 10 min at 1750 rpm at room temperature. The chimaeric adenoviruses present in the pelleted cells were subsequently extracted and purified using the following downstream processing protocol. The pellet was dissolved in 50 ml 10 mM  $\text{NaPO}_4^-$  and frozen at  $-20^\circ\text{C}$ . After thawing at  $37^\circ\text{C}$ , 5.6 ml deoxycholate (5% w/v) was added after which the solution was homogenated. The solution was subsequently incubated for 15 minutes at  $37^\circ\text{C}$  to crack the cells. After homogenizing the solution, 1875 µl (1M)  $\text{MgCl}_2^-$  was added and 5 ml 100% glycerol. After the addition of 375 µl DNase (10 mg/ ml) the solution was incubated for 30 minutes at  $37^\circ\text{C}$ . Cell debris was removed by centrifugation at 1880xg for 30 minutes at room temperature without the brake on. The

supernatant was subsequently purified from proteins by loading on 10 ml of freon. Upon centrifugation for 15 minutes at 2000 rpm without brake at room temperature three bands were visible of which the upper band represents the adenovirus. This band was isolated by pipetting after which it was loaded on a Tris/HCl (1M) buffered caesium chloride blockgradient (range: 1.2 to 1.4 gr./ml). Upon centrifugation at 21000 rpm for 2.5 hours at 10°C the virus was purified from remaining protein and cell debris since the virus, in contrast to the other components, did not migrate into the 1.4 gr./ ml cesium chloride solution. The virus band was isolated after which a second purification using a Tris/ HCl (1M) buffered continuous gradient of 1.33 gr./ml of cesium chloride is performed. After virus loading on top of this gradient the virus was centrifuged for 17 hours at 55000 rpm at 10°C. Subsequently the virus band was isolated and after the addition of 30 µl of sucrose (50 w/v) excess cesium chloride is removed by three rounds of dialysis, each round comprising of 1 hour. For dialysis the virus is transferred to dialysis slides (Slide-a-lizer, cut off 10000 kDa, Pierce, USA). The buffers used for dialysis are PBS which are supplemented with an increasing concentration of sucrose (round 1 to 3: 30 ml, 60 ml, and 150 ml sucrose (50% w/v)/ 1.5 liter PBS, all supplemented with 7.5 ml 2% (w/v) CaMgCl<sub>2</sub>). After dialysis, the virus is removed from the slide-a-lizer after which it is aliquoted in portions of 25 and 100 µl upon which the virus is stored at -85°C.

To determine the number of virusparticles per milliliter, 50 µl of the virus batch is run on an high performance liquid chromatograph columns (HPLC). The adenovirus is bound to the column (anion exchange) after which it is eluted using a NaCl gradient (range 300-600 mM). By determining the area under the viruspeak the number of virus particles can be calculated. To determine the number of infectious units (IU) per ml present in a virus batch, titrations are performed on 911 cells. For this purpose,

4x10<sup>4</sup> 911 cells are seeded per well of 96-well plates in rows E, D, and F in a total volume of 100 µl per well. Three hours after seeding the cells are attached to the plastic support after which the medium can be removed. To the cells a volume  
5 of 200 µl is added, in duplicate, containing different dilutions of virus (range: 10<sup>2</sup> times diluted to 2x10<sup>9</sup>). By screening for CPE the highest virus dilution which still renders CPE after 14 days is considered to contain at least one infectious unit. Using this observation, together with  
10 the calculated amount of virus volume present in these wells renders the number of infectious units per ml of a given virus batch. The production results i.e. virus particles per ml and IU per ml or those chimaeric adenoviruses that were produced so far, are shown in table 4.

15

**Example 4: Re-directed infection of chimaeric adenoviruses**

To demonstrate re-directed infection *in vitro* of the adenoviruses chimaeric for fiber protein, a panel of human  
20 cell lines of different origins was used. This panel includes amongst others human hepatic cells, primary fibroblasts, hemopoietic derived cell lines, primary smooth muscle cells, primary synoviocytes, and primary cells derived from the amniotic fluid such as amniocytes and chorionvilli. These  
25 cell types were infected with a panel of chimaeric adenoviruses which differ in the fiber protein. For this purpose target cells are seeded at a concentration of 10<sup>5</sup> cells per well of 6-well plates in 2 ml Dulbecco's modified Eagle's medium (DMEM, Life Technologies, The Netherlands)  
30 supplemented with 10% Fetal calf serum. Twenty-four hours later the medium is replaced by fresh medium containing the different chimaeric adenoviruses at an increasing MOI of 0, 10, 50, 250, 1250, 2500, 5000 (MOI based on virus particles per cell). Approximately 2 hours after the addition of virus  
35 the medium containing the virus is discarded, cells are

washed once with PBS, and subsequently 2 ml of fresh medium (not containing virus) is added to each well. Forty-eight hours later cells are harvested, washed and pelleted by centrifugating 5 minutes at 1500 rpm. Cells are subsequently lysed in 0,1 ml lysis buffer (1% Triton-X-100, 15% Glycerol, 2 mM EDTA, 2 mM DTT, and 25 mM MgCl<sub>2</sub> in Tris-phosphate buffer pH 7.8) after which the total protein concentration of the lysate is measured (Biorad, protein standard II). To determine marker gene expression (luciferase activity) 20 µl of the protein sample is mixed with 100 µl of a luciferase substrate (Luciferine, Promega, The Netherlands) and subsequently measured on a Lumat LB 9507 apparatus (EG & G Berthold, The Netherlands). The results of these infection experiments, given as the amount of luciferase activity (RLU) per µg protein, are shown in Table 5. These results clearly demonstrate that alteration of the fiber protein results in alteration of the adenovirus serotype 5 host range.

**Example 5: Receptor usage of Fiber chimaeric adenoviruses**

To determine what cellular molecules are used by the fiber chimaeric adenoviruses the expression of proteins known to be involved in adenovirus serotype 5 infection i.e. Coxsackie adenovirus receptor (CAR), MHC class I, and integrins ( $\alpha\beta 3$ ,  $\alpha\beta 5$ ) was measured. For this purpose,  $1 \times 10^5$  target cells were transferred to tubes (4 tubes per cell type) designed for flow cytometry. Cells were washed once with PBS/ 0.5% BSA after which the cells were pelleted by centrifugation for 5 minutes at 1750 rpm at room temperature. Subsequently, 10 µl of a 100 times diluted  $\alpha\beta 3$  antibody (Mab 1961, Brunswick chemie, Amsterdam, The Netherlands), a 100 times diluted antibody  $\alpha\beta 5$  (antibody (Mab 1976, Brunswick chemie, Amsterdam, The Netherlands), or 2000 times diluted CAR antibody (a kind gift of Dr. Bergelson, Harvard Medical School, Boston, USA (Hsu et al)) was added to the cell pellet

after which the cells were incubated for 30 minutes at 4°C in a dark environment. After this incubation, cells were washed twice with PBS/0.5% BSA and again pelleted by centrifugation for 5 minutes at 1750 rpm room temperature. To label the cells, 10 µl of rat anti mouse IgG1 labeled with phycoerythrine (PE) was added to the cell pellet upon which the cells were again incubated for 30 minutes at 4°C in a dark environment. Finally the cells were washed twice with PBS/0.5% BSA and analyzed on a flow cytometer. The results of these experiments are shown in table 5. Also, in table 6 the infection efficiency of an adenovirus from subgroup A, B, C, D, and F is incorporated. These data clearly show that infection of a subgroup C adenovirus correlates with expression of CAR. The data also demonstrate that the chimaeric adenoviruses carrying a fiber of an adenovirus of subgroup B, D, or F can infect cells that do not express measurable levels of the CAR protein thus being able to infect cells via different (CAR-independent) pathways.

#### 20 Example 6: Radiolabeling of adenovirus particles

To enable tracking of infection of the wild type adenovirus serotypes, these viruses were labeled with radioactive  $I^{123}/I^{125}$  or with fluorescent probes prior to infection. Using fluorescent microscopy or by measuring radioactivity, the efficiency of infection of different serotypes into particular cell types is determined.

To demonstrate re-directed infection in vivo of adenovirus chimaeric for fiber protein,  $1 \times 10^9$  infectious particles were injected via the tail vein into CBA/ca mice (2 mice for each chimaeric adenovirus). Detection of adenovirus infection into specific tissues is monitored on two different levels:

1) Binding of chimaeric adenovirus is monitored by radioactive labeling the adenovirus (Eisenlohr et al., 1987; Matlin et al., 1981; Richman et al, 1998). One hour after in vivo systemic delivery via the tail vein mice are sacrificed after which preferred is investigated by measuring radioactivity in

various organs c.q. tissues. 2) Successful infection is monitored by adenovirus gene expression of the marker gene i.e. lacZ or luciferase activity. Four days after administration mice are sacrificed after which organs and tissues are isolated. Samples included liver, spleen, gastrointestinal tract, peripheral blood, bone marrow, aorta, muscle etc. Using this strategy, preferred binding of chimaeric adenovirus towards tissues of interest can be investigated. Moreover, using this strategy, preferred infection of chimaeric adenovirus into specific cells of particular organs can be determined.

80  $\mu\text{Ci}$   $\text{I}^{125}$  (Cygne BV, The Netherlands) or  $\text{I}^{125}$  (Amersham) was activated by incubation for six minutes at RT in an Iodogen pre-coated tube (Pierce) in 100  $\mu\text{l}$  iodination buffer (25 mM Tris, pH8, 0.4 M NaCl). The radiolabeling reaction was started by transferring the activated Iodide to an Eppendorf tube containing  $1.5 \cdot 10^{10}$  adenovirus particles in 100  $\mu\text{l}$  iodination buffer. The reaction was allowed to proceed for nine minutes at RT, after which incorporated label was separated from free label by gelfiltration, using a Sephadex 25 column (P-10, Pharmacia). To this end, a P-10 column was pre-washed with 10 ml PBS buffer and subsequently loaded with the radiolabeling reaction, supplemented with two ml of iodination buffer. After discarding the first flow-through, the column was eluted with PBS buffer in 0.5 ml steps, and the different fractions were collected in separate tubes. Free label, which is slowed down by the column, was concentrated in fractions 10-16. Radiolabeled virus particles accumulated predominantly in fractions 4, 5 and 6, corresponding to a total eluted volume of 2-3 ml. The radioactivity of these virus-containing fractions was measured and expressed as counts per minute (cpm), resulting in up to  $5 \cdot 10^6$  cpm per  $10^{10}$  virus particles.

Several control experiments were conducted to ensure the integrity of the virus particles after the various manipulations. For instance, one reaction was included in

which the virus particles underwent identical treatment but with the omission of radioactive Iodide. Eluted virus particles were subsequently used to infect A549 cells. The amount of infected cells was established by the expression of a visual marker gene such as LacZ. In addition, small aliquots of those eluted fractions that represented radiolabeled adenovirus were used to infect A549 cells to test the expression of the transgene, which was taken as an indication for virus viability of the specific virus batch used.

The radiolabeled virus particles can subsequently be used for various *in vitro* and *in vivo* studies to determine the affinity for different cell types or for different organs. For *in vitro* studies, different cell lines such as for instance HUVEC (human umbilical vein endothelial cells) or SMC (smooth muscle cells) are seeded in 24-well plates in the appropriate culture medium, and infected with radiolabeled adenovirus particles at a multiplicity of infection of 10, 100 and 1000. As a control, cells are incubated with a similar amount of free Iodide. Two hours after infection, cells are extensively washed with PBS buffer, and the remaining radioactivity measured. The amount of radioactivity that remains associated with the cells, corrected for the amount of radioactivity of the control cells incubated with free label, is a direct measure for the amount of virus that is attached to or has penetrated the cells.

For *in vivo* studies, the biodistribution of adenoviruses that differ only in the origin of their fiber proteins was compared. To this end, rats were placed under general anesthetic and 0.1-2 MBq of radiolabeled adenovirus particles was intravenously (iv) administered into the tail vein. As a control, one rat received a comparable dose of free Iodide only. The animals were subsequently placed onto a gamma scanner and scanned for 10 minutes, to localize the source of the gamma radiation and thus to determine the *in vivo*

biodistribution of systemically introduced adenovirus. After one hour, animals were sacrificed and the major organs removed for weighing and for accurate quantification of radioactivity using a scintillation counter. The distribution of radioactivity in various organs after iv is expressed as cpm per gram tissue, and is shown in figure 8.

**Example 7: Infection of human primary cells from amniotic fluid.**

In Table 5 (example 4) infection results are shown on both amniotic cells and chorionvilli. These cell types are isolated from the amniotic fluid and cultured ex vivo under standard conditions (Roest et al, 1996). Such cells are ideal targets to use for prenatal diagnosis. For instance, in some cases (approximately 50-100 yearly) prenatal diagnosis of muscular dystrophin is impossible using standard techniques such as reverse-transcribed PCR or DNA PCR because the mutations in the dystrophin gene are unknown and the level of dystrophin produced in non-differentiated chorionvilli or amnionvilli cells is very low. In these cases isolation and fast differentiation of predominantly chorionvilli cells is performed. These chorionvilli are subsequently infected with a retrovirus (Roest et al, 1996) or an adenovirus carrying the MyoD cDNA (Roest et al, 1999) which, upon transduction, triggers the chorionvilli to differentiate into striated muscle cells within one week. After complete differentiation these cells can then be used for Western analysis, or immunohistochemistry to determine whether the dystrophin protein is expressed. To date, the infection efficiency of chorionvilli cells has been disappointing with only 2-5% of cells transduced with a retrovirus (Roest et al, 1996). Using a serotype 5 adenovirus to deliver the MyoD cDNA to chorionvilli approximately 10%-20% (Roest et al, 1999) of the cells can be transduced but only when using high multiplicity of infection (MOI) which results in undesired

toxicity and thus cell death. The results in Table 5 clearly demonstrate that the adenovirus serotype 5 is not an ideal candidate for transducing chorionvilli cells since only marginal luciferase activity is measured (75 RLU/  $\mu$ g protein) at the highest MOI tested (MOI = 5000 virusparticles per cell). These results are confirmed using flow cytometry for the presence of the Coxsackie adenovirus receptor (CAR) and integrins which demonstrates that the receptors for adenovirus serotype 5 are only marginally present on chorionvilli (Table 6). Surprisingly, the adenovirus serotype 5 based vector containing a fiber of either subgroup B (fiber 16 and/or 51) or subgroup F (fiber 40-L) both transduce the chorionvilli with high efficiency. The vector which does best, based on luciferase activity is the adenovirus 5 with fiber 40-L which results in 1,688,028 relative light units per  $\mu$ g of protein, >20,000 fold increased transgene expression as compared to adenovirus serotype 5. This vector can thus be used to transduce cells present in the amniotic fluid to allow fast differentiation for purposes described above, for inhibiting gene expression during prenatal development, or to transfer and express nucleic acid of interest to the amniotic fluid.

**Example 8: Generation of adenovirus serotype 5 based viruses with chimaeric hexon protein.**

The method described *infra* to generate recombinant adenoviruses by co-transfection of two, or more separate cloned adenovirus sequences. These cloned adenoviral sequences were subsequently used to remove specific adenovirus serotype 5 sequences in order to generate template clones which allow for the easy introduction of DNA sequences derived from other adenovirus serotypes. As an example of these template clones, the construction of

plasmids enabling swapping of DNA encoding for hexon protein is given.

Generation of adenovirus template clones lacking DNA

5 encoding for hexon

Hexon coding sequences of adenovirus serotype 5 are located between nucleotides 18841 and 21697. To facilitate easy exchange of hexon coding sequences from alternative adenovirus serotypes into the adenovirus serotype 5 backbone, 10 first a shuttle vector was generated. This subclone, coded pBr/Ad.Eco-PmeI, was generated by first digesting plasmid pBr322 with EcoRI and EcoRV and inserting the 14 kb PmeI-EcoRI fragment from pWE/Ad.AflII-Eco. In this shuttle vector a deletion was made of a 1430 bp SanDI fragment by digestion 15 with SanDI and religation to give pBr/Ad.Eco-PmeI ΔSanDI. The removed fragment contains unique SpeI and MuiI sites. From pBr/Ad.Eco-PmeIΔSanDI the adenovirus serotype 5 DNA encoding hexon was deleted. Hereto, the hexon flanking sequences were PCR amplified and linked together thereby generating unique 20 restriction sites replacing the hexon coding region. For these PCR reactions four different oligonucleotides were required: Δhex1-Δhex4. Δhex1: 5'- CCT GGT GCT GCC AAC AGC-3'  
 Δhex2: 5'- CCG GAT CCA CTA GTG GAA AGC GGG CGC GCG-3'  
 Δhex3: 5'- CCG GAT CCA ATT GAG AAG CAA GCA ACA TCA ACA AC-3'  
 25 Δhex4: 5'- GAG AAG GGC ATG GAG GCT G-3' (See figure 9).  
 The amplified DNA product of ± 1100 bp obtained with oligonucleotides Δhex1 and Δhex2 was digested with BamHI and FseI. The amplified DNA product of ± 1600 bp obtained with oligonucleotides Δhex3 and Δhex4 was digested with BamHI and 30 SbfI. These digested PCR fragments were subsequently purified from agarose gel and in a tri-part ligation reaction using T4 ligase enzyme linked to pBr/Ad.Eco-PmeI ΔSanDI digested with FseI and SbfI. The resulting construct was coded pBr/Ad.Eco-PmeIΔHexon. This construct was sequenced in part to confirm 35 the correct nucleotide sequence and the presence of unique restriction sites MuiI and SpeI.

Amplification of hexon sequences from adenovirus serotypes

To enable amplification of the DNAs encoding hexon protein derived from alternative serotypes degenerate oligonucleotides were synthesized. For this purpose, first known DNA sequences encoding for hexon protein of alternative serotypes were aligned to identify conserved regions in both the N-terminus as well as the C-terminus of the Hexon protein. From the alignment, which contained the nucleotide sequence of 9 different serotypes representing 5 of the 6 known subgroups, (degenerate) oligonucleotides were synthesized. These oligonucleotides were coded HEX-up (5'- GG ACGTGT AAG ATG GCY ACC CCH TCG ATG MTG- 3') and HEX-down (5'- CCA TCG ATG GTT ATG TKG TKG CGT TRC CGG C -3'). The amplification reaction (50 µl) contained 2 mM dNTPs, 25 pmol of each oligonucleotide, standard 1x PCR buffer, 1,5 mM MgCl<sub>2</sub>, and 1 Unit Pwo heat stable polymerase (Boehringer) per reaction. The cycler program contained 20 cycles, each consisting of 30 sec. 94°C, 60 sec. 60-64°C, and 120 sec. At 72°C. One-tenth of the PCR product was run on an agarose gel which demonstrated that a DNA fragment was amplified. Of each different template, two independent PCR reactions were performed after which the independent PCR fragments obtained were sequenced to determine the nucleotide sequence. From 9 different serotypes, the nucleotide sequence could be compared to sequences present in GenBank. Of all other serotypes, the nucleotide sequence encoding the Hexon protein is unknown. So far, of each serotype, except for serotypes 1, 8, 13, and 18, the hexon sequence has been PCR amplified. The protein sequence of the hexon of serotypes 34, 35, 36, and 41 is given in figure 10.

Generation of Hexon chimaeric adenoviral DNA constructs

All amplified hexon DNAs as well as the vector (pBr/Ad.Eco-PmeΔHexon) were digested with MunI and SpeI. The digested

DNA was subsequently run on an agarose gel after which the fragments were isolated from the gel and purified using the GeneClean kit (Bio101 Inc). The PCR fragments were then cloned into the *MunI* and *SpeI* sites of pBr/Ad.Eco-PmeΔHexon, thus generating pBr/Ad.Eco-PmeΔHexXX (where XX stands for the serotype number of which the fiber DNA was isolated). So far the hexon sequence of serotypes 2, 3, 4, 5, 7, 9, 10, 11, 14, 15, 16, 19, 20, 22, 23, 25, 26, 27, 28, 29, 30, 31, 32, 33, 34, 35, 36, 37, 38, 40, 41, 42, 43, 46, 47, 48, 49, 50, 51 have been cloned into pBr/Ad.Eco-PmeΔHexXX. From pBr/Ad.Eco-PmeΔHexXX (where XX is 20, 25, 26, 28, 30, 34, 35) a 9.6 kb *AscI* fragment encompassing the hexon sequence was isolated via gelelectrophoresis and an agarose protocol (Boehringer Mannheim, The Netherlands). This *AscI* fragment was subsequently cloned in cosmid pWE/Ad.AflIII-rITRsp (see example 1) which was digested to completion with *AscI* and dephosphorylated as described previously. This cosmid cloning resulted in the formation of construct pWE/Ad.AflIII-rITR/HexXX (where XX stands for the serotype number of which the hexon DNA was isolated)

#### Generation of recombinant adenovirus chimaeric for hexon protein

To generate recombinant Ad 5 virus carrying the hexon of alternative serotypes two constructs, pCLIP.Luc, pWE/Ad.AflIII-rITR/HexXX were transfected into adenovirus producer cells. For transfection, 4 μg of pCLIP.Luc, and 4 μg of pWE/Ad.AflIII-rITR/HexXX were diluted in serum free DMEM to 100 μl total volume. To this DNA suspension 100 μl 2/3 x diluted lipofectamine (Gibco) was added. After 30 minutes at room temperature the DNA-lipofectamine complex solution was added to 2.5 ml of serum-free DMEM which was subsequently added to a T25 cm<sup>2</sup> tissue culture flask (cells washed with 5 ml serumfree medium prior to addition of DNA-lipofectamine complex). This flask contained 3 x 10<sup>6</sup> PER.C6 cells that were

seeded 24-hours prior to transfection. Two hours later, the DNA-lipofectamine complex containing medium was diluted once by the addition of 2.5 ml DMEM supplemented with 20% fetal calf serum. Again 24 hours later the medium was replaced by fresh DMEM supplemented with 10% fetal calf serum. Cells were cultured for 6-8 days, subsequently harvested, and freeze/thawed. Cellular debris was removed by centrifugation for 5 minutes at 3000 rpm room temperature. Of the supernatant (12.5 ml) 3-5 ml was used to again infect PER.C6 cells (T80 cm<sup>2</sup> tissue culture flasks).

Re-directed neutralization towards hexon chimaeric adenovirus

To demonstrate an altered immune response towards chimaeric adenoviruses, we first tested 75 sera derived from human patients (25 cancer patients, 50 rheumatoid arthritis patients) for toxicity on human 911 cells. For this purpose, 911 cells were seeded at a concentration of  $3 \times 10^4$  cells per well in 96-well microtiter plates. Twenty-four hours later the medium of all wells, except for wells A1-H1, A5-H5, and A9-H9, was replaced by 50  $\mu$ l DMEM supplemented with 5% fetal calf serum. To wells A1, A2, B1, and B2, 50  $\mu$ l patient serum 1 was added. Likewise, To wells C1, C2, D1, and D2, 50  $\mu$ l of patient serum 2 was added etc. Subsequently, 50  $\mu$ l of wells A2-H2 were transferred to A3-H3 after which 50  $\mu$ l of wells A3-H3 was transferred to A4-H4. Thus this test schedule resulted in a serum dilution of 0x, 2x, 4x, and 8x for each patient serum. Identical treatment of wells A5-H5 through A8-H8, and A9-H9 through A12-H12 results in 12 sera tested per 96-well microtiter plate. From 75 human patient sera tested in total, 25 sera with no apparent toxicity on human 911 cells were subsequently tested for the presence of antibodies capable of neutralizing chimaeric adenovirus infection. For this purpose, 96-well microtiter plates were filled with 50  $\mu$

1 DMEM supplemented with 5% fetal calf serum except for wells  
A1-H1. To wells A1, A2, B1, and B2, 50 µl patient serum 1 was  
added. Likewise, to wells C1, C2, D1, and D2, 50 µl patient  
serum 2 was added etc. Subsequently, 50 µl of wells A2-H2  
5 were transferred to wells A3-A4 after which 50 µl of A3-H3  
was transferred to A4-H4 etc. until A12-H12 (dilution range:  
0 - 1/ 2048). From wells A12-H12, 50 µl was discarded. Next,  
50 µl of virus was added after which the microtiter plates  
were incubated for 1 hour at 37°C. Upon the addition of 50 µl  
10 911 cell-suspension ( $3 \times 10^4$  cells/ well) plates were  
incubated for 7-9 days after which neutralizing capacity was  
scored by the absence, presence, or severity of CPE. As  
controls during these experiments absence of serum, absence  
of virus, and absence of serum and virus were taken. Based on  
15 these experiments several chimaeric viruses are identified  
towards which little neutralizing antibodies are generated by  
humans. Similar experiments as described above are performed  
with wildtype adenovirus serotypes from both human as well as  
animals to screen for serotypes which are less prone to  
20 neutralization due to the host defense system. These  
experiments although similar are developed in such a way that  
it allows high throughput screening of many samples at once.  
This assay is described below.

25 A high throughput assay for the detection of neutralizing  
activity in human serum

To enable screening of a large amount of human sera for the  
presence of neutralizing antibodies against all adenovirus  
30 serotypes, an automated 96-wells assay was developed.  
*Human sera*

A panel of 100 individuals was selected. Volunteers (50%  
male, 50% female) were healthy individuals between 20 and 60  
years old with no restriction for race. All volunteers signed

an informed consent form. People professionally involved in adenovirus research were excluded.

Approximately 60 ml blood was drawn in dry tubes. Within two hours after sampling, the blood was centrifuged at 2500 rpm for 10 minutes. Approximately 30 ml serum was transferred to polypropylene tubes and stored frozen at -20°C until further use.

Serum was thawed and heat-inactivated at 56°C for 10 minutes and then aliquotted to prevent repeated cycles of freeze/thawing. Part was used to make five steps of twofold dilutions in medium (DMEM, Gibco BRL) in a quantity enough to fill out approximately 70 96-well plates. Aliquots of undiluted and diluted sera were pipetted in deep well plates (96-well format) and using a programmed platemate dispensed in 100 µl aliquots into 96-well plates. This way the plates were loaded with eight different sera in duplo (100 µl/well) according to the scheme below:

S1/2	S1/4	S1/8	S1/16	S1/32	S5/2	S5/4	S5/8	S5/16	S5/32	-	-
S1/2	S1/4	S1/8	S1/16	S1/32	S5/2	S5/4	S5/8	S5/16	S5/32	-	-
S2/2	S2/4	S2/8	S2/16	S2/32	S6/2	S6/4	S6/8	S6/16	S6/32	-	-
S2/2	S2/4	S2/8	S2/16	S2/32	S6/2	S6/4	S6/8	S6/16	S6/32	-	-
S3/2	S3/4	S3/8	S3/16	S3/32	S7/2	S7/4	S7/8	S7/16	S7/32	-	-
S3/2	S3/4	S3/8	S3/16	S3/32	S7/2	S7/4	S7/8	S7/16	S7/32	-	-
S4/2	S4/4	S4/8	S4/16	S4/32	S8/2	S8/4	S8/8	S8/16	S8/32	-	-
S4/2	S4/4	S4/8	S4/16	S4/32	S8/2	S8/4	S8/8	S8/16	S8/32	-	-

Where S1/2 to S8/2 in columns 1 and 6 represent 1x diluted sera and Sx/4, Sx/8, Sx/16 and Sx/32 the twofold serial dilutions. The last plates also contained four wells filled with 100 µl fetal calf serum as a negative control. Plates were kept at -20°C until further use.

*Preparation of human adenovirus stocks*

Prototypes of all known human adenoviruses were inoculated on T25 flasks seeded with PER.C6 cells (Fallaux et al., 1998) and harvested upon full CPE. After freeze/thawing 1-2 ml of the crude lysates were used to inoculate a T80 flask with PER.C6 cells and virus was harvested at full CPE. The time frame between inoculation and occurrence of CPE as well as the amount of virus needed to re-infect a new culture, differed between serotypes. Adenovirus stocks were prepared by freeze/thawing and used to inoculate 3-4 T175 cm<sup>2</sup> three-layer flasks with PER.C6 cells. Upon occurrence of CPE, cells were harvested by tapping the flask, pelleted and virus was isolated and purified by a two step CsCl gradient as follows.

Cell pellets were dissolved in 50 ml 10 mM NaPO<sub>4</sub> buffer (pH 7.2) and frozen at -20°C. After thawing at 37°C, 5.6 ml sodium deoxycholate (5% w/v) was added. The solution was mixed gently and incubated for 5-15 minutes at 37°C to completely lyse the cells. After homogenizing the solution, 1875 µl 1M MgCl<sub>2</sub> was added. After the addition of 375 µl DNase (10 mg/ml) the solution was incubated for 30 minutes at 37°C. Cell debris was removed by centrifugation at 1880xg for 30 minutes at RT without brake. The supernatant was subsequently purified from proteins by extraction with freon (3x). The cleared supernatant was loaded on a 1M Tris/HCl buffered cesium chloride blockgradient (range: 1.2/1.4 gr/ml) and centrifuged at 21000 rpm for 2.5 hours at 10°C. The virus band is isolated after which a second purification using a 1M Tris/HCl buffered continuous gradient of 1.33 gr/ml of cesium chloride was performed. The virus was then centrifuged for 17 hours at 55000 rpm at 10°C. The virus band is isolated and sucrose (50 % w/v) is added to a final concentration of 1%. Excess cesium chloride is removed by dialysis (three times 1 hr at RT) in dialysis slides (Slide-a-lizer, cut off 10000 kDa, Pierce, USA) against 1.5 ltr PBS supplemented with CaCl<sub>2</sub> (0.9 mM), MgCl<sub>2</sub> (0.5mM) and an increasing concentration of

sucrose (1, 2, 5%). After dialysis, the virus is removed from the slide-a-lizer after which it is aliquoted in portions of 25 and 100  $\mu$ l upon which the virus is stored at  $-85^{\circ}\text{C}$ .

To determine the number of virus particles per milliliter, 50  $\mu$ l of the virus batch is run on a high-pressure liquid chromatograph (HPLC) as described by Shabram et al (1997). Viruses were eluted using an NaCl gradient ranging from 0 to 600 mM. As depicted in table I, the NaCl concentration by which the viruses were eluted differed significantly among serotypes.

Most human adenoviruses replicated well on PER.C6 cells with a few exceptions. Adenovirus type 8 and 40 were grown on 911-E4 cells (He et al., 1998). Purified stocks contained between  $5 \times 10^{10}$  and  $5 \times 10^{12}$  virus particles/ml (VP/ml)

#### Titration of purified human adenovirus stocks

Adenoviruses were titrated on PER.C6 cells to determine the amount of virus necessary to obtain full CPE in five days, the length of the neutralization assay. Hereto, 100  $\mu$ l medium was dispensed into each well of 96-well plates. 25  $\mu$ l of adenovirus stocks prediluted  $10^4$ ,  $10^5$ ,  $10^6$  or  $10^7$  times were added to column 2 of a 96-well plate and mixed by pipetting up and down 10 times. Then 25  $\mu$ l was brought from column 2 to column 3 and again mixed. This was repeated until column 11 after which 25  $\mu$ l from column 11 was discarded. This way serial dilutions in steps of 5 were obtained starting off from a prediluted stock. Then  $3 \times 10^4$  PER.C6 cells were added in a 100  $\mu$ l volume and the plates were incubated at  $37^{\circ}\text{C}$ , 5%  $\text{CO}_2$  for five or six days. CPE was monitored microscopically. The method of Reed and Muensch was used to calculate the cell culture inhibiting dose 50% (CCID50).

In parallel identical plates were set up that were analyzed using the MTT assay (Promega). In this assay living cells are quantified by colorimetric staining. Hereto, 20  $\mu$ l MTT (7.5 mgr/ml in PBS) was added to the wells and incubated at  $37^{\circ}\text{C}$ , 5%  $\text{CO}_2$  for two hours. The supernatant was removed

and 100  $\mu$ l of a 20:1 isopropanol/triton-X100 solution was added to the wells. The plates were put on a 96-wells shaker for 3-5 minutes to solubilise precipitated staining. Absorbance was measured at 540 nm and at 690 nm (background).  
5 By this assay wells with proceeding CPE or full CPE can be distinguished.

#### Neutralization assay

10 96-well plates with diluted human serum samples were thawed at 37  $^{\circ}$ C, 5% CO<sub>2</sub>. Adenovirus stocks diluted to 200 CCID50 per 50  $\mu$ l were prepared and 50  $\mu$ l aliquots were added to columns 1-11 of the plates with serum. Plates were incubated for 1 hour at 37 $^{\circ}$ C, 5% CO<sub>2</sub>. Then 50  $\mu$ l PER.C6 cells at 6x10<sup>5</sup>/ml were  
15 dispensed in all wells and incubated for 1 day at 37  $^{\circ}$ C, 5% CO<sub>2</sub>. Supernatant was removed using fresh pipet tips for each row and 200  $\mu$ l fresh medium was added to all wells to avoid toxic effects of the serum. Plates were incubated for another 4 days at 37  $^{\circ}$ C, 5% CO<sub>2</sub>. In addition, parallel control plates  
20 were set up in duplo with diluted positive control sera generated in rabbits and specific for each serotype to be tested in rows A and B and with negative control serum (FCS) in rows C and D. Also, in each of the rows E-H a titration was performed as described above with steps of five times  
25 dilutions starting with 200 CCID50 of each virus to be tested. On day 5 one of the control plates was analyzed microscopically and with the MTT assay. The experimental titer was calculated from the control titration plate observed microscopically. If CPE was found to be complete,  
30 i.e. the first dilution in the control titration experiment analyzed by MTT shows clear cell death, all assay plates were processed. If not, the assay was allowed to proceed for one or more days until full CPE was apparent after which all plates were processed. In most cases the assay was terminated  
35 at day 5. A serum sample is regarded to be non-neutralizing when at the highest serum concentration a maximum protection is seen of 40% compared to the controls without serum.

**Example 9: Generation of Ad5 based viruses with chimaeric penton proteins**

5 The method described *infra* to generate recombinant adenoviruses by co-transfection of two, or more separate cloned adenovirus sequences. These cloned adenoviral sequences were subsequently used to remove specific adenovirus serotype 5 sequences in order to generate template clones which allow for the easy introduction of DNA sequences  
10 derived from other adenovirus serotypes. As an example of these template clones, the construction of plasmids enabling swapping of DNA encoding for penton protein is given.

15 Generation of adenovirus template clones lacking DNA encoding for penton

First a shuttle vector for penton sequences was made by insertion of the 7.2 kb NheI-EcoRV fragment from construct  
20 pWE/Ad.AflIII-EcoRI (described in example 1) into pBr322 digested with the same enzymes. The resulting vector was named pBr/XN. From this plasmid Ad5 penton sequences were deleted and replaced by unique restriction sites that are then used to introduce new penton sequences from other  
25 serotypes. Hereto, the left flanking sequences of penton in pBr/XN were PCR amplified using the following primers:  
DP5-F: 5'- CTG TTG CTG CTG CTA ATA GC-3' and  
DP5-R: 5'- CGC GGA TCC TGT ACA ACT AAG GGG AAT ACA AG-3'  
DP5-R has an BamHI site (underlined) for ligation to the  
30 right flanking sequence and also introduces a unique BsrGI site (bold face) at the 5'-end of the former Ad5 penton region.

The right flanking sequence was amplified using:

DP3-F: 5'-CGC GGA TCC CTT AAG GCA AGC ATG TCC ATC CTT-3' and  
35 DP3-3R: 5'- AAA ACA CGT TTT ACG CGT CGA CCT TTC-3'

DP3-F has an BamHI site (underlined) for ligation to the left flanking sequence and also introduces a unique AflIII site (bold face) at the 3'-end of the former Ad5 penton region. The two resulting PCR fragments were digested with BamHI and ligated together. Then this ligation mixture was digested with AvrII and BglII. pBr/XN was also digested with AvrII and BglII and the vector fragment was ligated to the digested ligated PCR fragments. The resulting clone was named pBr/Ad.Δ penton. Penton coding sequences from serotypes other than Ad5 were PCR amplified such that the 5' and 3' ends contained the BsrGI and AflIII sites respectively. Introduction of these heterologous penton sequences in pBr/Ad.Δpenton generates constructs named pBr/Ad.pentonXX where XX represents the number of the serotype corresponding to the serotype used to amplify the inserted penton sequences. Subsequently the new penton sequences were introduced in the pWE/Ad.AflIII-rITR construct by exchanging the common FseI fragment. Importantly, in stead of pWE/Ad.AflIII-rITR it is also possible to insert the FseI fragment from pBr/Ad.pentonXX into a pWE/Ad.AflIII-rITR/HexXX or an pWE/Ad.AflIII-rITR/FibXX vector having a modified hexon and/or fiber sequence respectively. In this way the plasmid-based system to generate adenoviruses enables flexible design of any adenovirus with any desired characteristic concerning efficiency and specificity of infection of the target cell as well as immunogenicity.

#### Amplification of penton sequences from adenovirus serotypes

To enable amplification of the DNAs encoding penton protein derived from alternative serotypes oligonucleotides were synthesized. Of each adenovirus subgroup the penton sequence of only one member is known to date. Therefore, oligonucleotides were designed based on the known sequences. Thus, for amplification of penton sequences from subgroup C oligonucleotides P5-for (5'-

gctc gatgtacaatg cggcg cggcg gatgtat-3') and P5-rev (5'-  
gctc gacttaagtcaaaaagtcgggctcgatag-3') were used .For the  
amplification of penton sequences from subgroup B  
oligonucleotides P3-for (5'gctc gatgtacaatgaggagacgagccg  
5 tgcta-3') and P3-rev (5'-gctc gacttaagttagaaaagtcgggcttgaaag-  
3') were used. For the amplification of penton sequences from  
subgroup D oligonucleotides P17-for (5'gctc gatgtacaatgaggcgt  
gcggtgtgtcttc-3') and P17-rev (5'-gctc gacttaagttagaagggtcgc  
actggaaagc-3') were used. For the amplification of penton  
10 sequences from subgroup F oligonucleotides PF-for (5'-  
gctc gatgtacaatgagacgtg cgggtgggagtg-3') and PF-rev (5'-gctcga  
cttaagttaaaagtcgggtagacag-3') were used. All above  
described forward oligonucleotides contain a BsrGI  
restriction site at their 5'-end and all reverse  
15 oligonucleotides contain an AflII restriction site at the 5'-  
end.

The amplification reaction (50 µl) contained 2 mM dNTPs, 25  
pmol of each oligonucleotide, standard 1x PCR buffer, 1,5 mM  
MgCl<sub>2</sub>, and 1 Unit Pwo heat stable polymerase (Boehringer) per  
20 reaction. The cycler program contained 20 cycles, each  
consisting of 30 sec. 94°C, 60 sec. 60-64°C, and 120 sec. At  
72°C. One-tenth of the PCR product was run on an agarose gel  
which demonstrated that a DNA fragment was amplified. Of each  
different template, two independent PCR reactions were  
25 performed after which the independent PCR fragments obtained  
are sequenced to determine the nucleotide sequence. Of the 51  
human serotypes 20 penton sequences have been amplified.

#### Generation of penton chimaeric adenoviral DNA constructs

30 All amplified penton DNAs as well as the vector (pBr/Ad.Δ  
penton) were digested with BsrGI and AflII. The digested DNAs  
was subsequently run on a agarose gel after which the  
fragments were isolated from the gel and purified using the  
GeneClean kit (Bio101 Inc). The PCR fragments were then  
35 cloned into the BsrGI and AflII sites of pBr/Ad.Δpenton, thus  
generating pBr/Ad.pentonXX (where XX stands for the serotype

number of which the penton DNA was isolated). So far the penton sequence of serotypes 2, 3, 5, 6, 7, 11, 21, 26, 35, 39, 40, 41, 42, 47, 48, 49 and 51 have been cloned into pBr/Ad.pentonXX. From pBr/Ad.pentonXX an 5.1 kb FseI  
5 fragment encompassing the penton sequence was isolated via gelelectrophoresis and GeneClean. This FseI fragment was subsequently cloned in cosmid pWE/Ad.AflIII-rITR (see example 1) which was digested to completion with FseI and dephosphorylated as described previously. This cosmid cloning  
10 resulted in the formation of construct pWE/Ad.AflIII-rITR/PentonXX (where XX stands for the serotype number of which the penton DNA was isolated).

15 Generation of recombinant adenovirus chimaeric for penton protein

To generate recombinant Ad 5 virus carrying the Penton of alternative serotypes two constructs, pCLIP.Luc and pWE/Ad.AflIII-rITR/PenXX were transfected into adenovirus producer cells.  
20 For transfection, 4 µg of pCLIP.Luc and 4 µg of pWE/Ad.AflIII-rITR/PentonXX were diluted in serum free DMEM to 100 µl total volume. To this DNA suspension 100 µl 1x diluted lipofectamine (Gibco) was added. After 30 minutes at room temperature the DNA-lipofectamine complex solution was added  
25 to 2.5 ml of serum-free DMEM which was subsequently added to a T25 cm<sup>2</sup> tissue culture flask. This flask contained 2x10<sup>6</sup> PER.C6 cells that were seeded 24-hours prior to transfection. Two hours later, the DNA-lipofectamine complex containing medium was diluted once by the addition of 2.5 ml DMEM  
30 supplemented with 20% fetal calf serum. Again 24 hours later the medium was replaced by fresh DMEM supplemented with 10% fetal calf serum. Cells were cultured for 6-8 days, subsequently harvested, and freeze/thawed 3 times. Cellular debris was removed by centrifugation for 5 minutes at 3000  
35 rpm room temperature. Of the supernatant (12.5 ml) 3-5 ml was

WO 00/03029

PCT/NL99/00436

57

used to infect again infect PER.C6 cells (T80 cm<sup>2</sup> tissue culture flasks). This re-infection results in full cytopathogenic effect (CPE) after 5-6 days after which the adenovirus is harvested as described above.

5

The above described examples 1-9 encompasses the construction of recombinant adenoviral vectors, chimaeric for either fiber protein or hexon protein which results in an altered infection host range or altered immune response towards adenoviral vectors. These chimaeric adenoviral vectors are generated for the purpose of gene transfer and recombinant DNA vaccines. It must be stressed that in a manner analogous as described under example 1-9 chimaeric adenoviral vectors are constructed for penton and can be constructed for all other adenovirus proteins including but not limited to DNA encoding for small proteins required for adenovirus assembly and sequences required for adenovirus replication. Moreover, it must be emphasized that with this technology double, triple, quadruple, etc chimaeric adenoviral vectors can be constructed with the aim to combine parts of existing adenovirus serotypes to generate adenoviral vectors with preferred characteristics for any given target cell or target disease.

25

The reference to any prior art in this specification is not, and should not be taken as, an acknowledgment or any form of suggestion that that prior art forms part of the common general knowledge in Australia.

30

Throughout this specification and the claims which follow, unless the context requires otherwise, the word "comprise", and variations such as "comprises" and "comprising", will be understood to imply the inclusion of a stated integer or step or group of integers or steps but not the exclusion of any other integer or step or group of integers or steps.

35

## Legends to figures and tables

5 Table 1: Summary of the classification of known human  
adenovirus serotypes based upon the principle of  
hemagglutination.

Table 2: Association of human adenovirus serotypes with  
10 human disease.

Table 3: Oligonucleotides and degenerate oligonucleotides  
used for the amplification of DNA encoding for fiber protein  
derived from alternative human adenovirus serotypes. Bold  
15 letters in oligonucleotides A-E represent an NdeI restriction  
site. Bold letters in oligonucleotides 1-6 and 8 represent an  
NsiI restriction site. Bold letters in oligonucleotide 7  
represent a PacI restriction site.

20 Table 4: Production results of fiber chimaeric adenoviruses.  
The number of virus particles per ml were determined using  
HPLC. The number of infectious units (IU) per milliliter were  
determined through titration on human 911 cells. For  
infection experiments, the number of virus particles per  
25 milliliter is taken from all chimaeric adenoviruses since IU/  
ml reflects a receptor mediated process.

Table 5: Transduction results of human cell lines and  
primary cells. A549: Human lung carcinoma cell line (ATCC,  
30 CCL-1185). K562: Human erythroid leukemia (ATCC, CCL-243).  
SupT1: Human Lymphoblast hybrid B and T (ATCC, CRL-1991).  
GM09503: Human primary fibroblasts. HEPG2: Human liver  
carcinoma (ATCC, HB8065). CEM: human lymphoblast cells (ATCC,  
CRL-1992). HeLa: Human cervix carcinoma (ATCC, CCL-2).  
35 Primary amniocytes and chorionvilli cells were obtained from  
department of antropogenetics, Leiden, The Netherlands.

Primary Smooth muscle cells and synoviocytes were obtained from TNO-PG, Leiden, The Netherlands. Shown are the luciferase activity (in relative light units (RLU) per  $\mu$ g protein) measurements of cells infected at MOI 5000 virusparticles per cell.

Table 6: Expression of integrins  $\alpha_v\beta_3$  and  $\alpha_v\beta_5$ , the Coxsackie adenovirus receptor (CAR), and MHC class I on the membranes of target cells. In addition to the cells described in table 5: HUVEC: human umbilical vein endothelial cells were obtained from TNO-PG, Leiden, The Netherlands. Shown is the percentage of cells expressing either molecule on their membrane. The Ad5 based vector carrying a fiber of one representative of each subgroup and the efficiency of infection is shown on the right of the table. ND: not determined. 0% means undetectable expression of the molecule on the membrane of the cell using flow cytometry. 100% means high expression of the molecule on the cell membrane.

Figure 1: Schematic presentation of adapter plasmid pMLPI.TK.

Figure 2: Schematic presentation of adapter plasmid pAd/L420-HSA.

Figure 3: Schematic presentation of adapter plasmid pAd5/CLIP

Figure 4: Schematic presentation of a two plasmid system for the generation of recombinant adenoviruses.

Figure 5: Schematic presentation of a three plasmid system for the generation of recombinant adenoviruses.

Figure 6: Schematic presentation of generation of plasmid pBr/AdBamRDeltaFib in which part of the Adenovirus type 5 fiber DNA is replaced by a short DNA stretch containing a unique NsiI site.

Figure 7: Fiber protein sequences of adenovirus serotypes 8, 9, 13, 14, 20, 23, 24, 25, 27, 28, 29, 30, 32, 33, 34, 35, 36, 37, 38, 39, 42, 43, 44, 45, 46, 47, 48, 49, and 51. Bold letters represent part of the tail of adenovirus serotype 5. If bold letters not present it means that a PCR fragment was sequenced which did not contain the Ad5 tail. An X, present in the sequence means unidentified amino acid due to unidentified nucleotide. At the end of the sequence the stop codon of the fiber is presented by a dot.

Figure 8: Comparison of the *in vivo* biodistribution of  $I^{123}$  labeled adenovirus serotype 5 and an adenovirus chimaeric for fiber protein. Radiolabeled adenovirus ( $10^{10}$  virus particles, 0.1-2 MBq) was intravenously administered into the tail vein. As a control, a similar amount of free label was injected into the control animal. Rats were sacrificed after one hour and organs calibrated. Radioactivity of the in the figure indicated organs was measured with a scintillation counter and is expressed as counts per minute per gram tissue.

Figure 9: Schematic presentation of the generation of plasmid pBr/Ad.Eco-Pme $\Delta$ Hexon. Also shown is the sequence of the oligonucleotides delta hex 1-4 used to delete the DNA encoding for the hexon of adenovirus serotype 5 protein.

Figure 10: Hexon protein sequences of adenovirus serotypes 34, 35, 36, and 41. An X, present in the sequence means unidentified amino acid due to unidentified nucleotide. At the end of the sequence the stop codon of the hexon is presented by a dot.

**References**

- Arnberg N., Mei Y. and Wadell G., 1997. Fiber genes of adenoviruses with tropism for the eye and the genital tract. *Virology* 227: 239-244.
- Bout A., 1997. Gene therapy, p. 167-182. In: D.J.A. Crommelin and R.D. Sindelar (ed.), *Pharmaceutical biotechnology*, Harwood Academic Publishers.
- Bout, A. 1996. Prospects for human gene therapy. *Eur. J. drug Met. And Pharma.* 2, 175-179.
- Blaese et al., *Cancer Gene Ther.*, 2 (1995):291-297).
- Brody and Crystal, *Ann. N. Y. Acad. Sci.* 716(1994):90-101.
- Chroboczek J., Ruigrok R.W.H., and Cusack S., 1995. Adenovirus fiber, p. 163-200. In: W. Doerfler and P. Bohm (ed.), *The molecular repertoire of adenoviruses, I.* Springer-Verlag, Berlin.
- Defer C., Belin M., Caillet-Boudin M. and Boulanger P., 1990. Human adenovirus-host cell interactions; comparative study with members of subgroup B and C. *Journal of Virology* 64 (8): 3661-3673.
- De Jong, J.C., Wermenbol, A.G., Verweij-Uijterwaal, M.W., Slaterus, K.W., Wertheim-van Dillen, P., van Doornum, G.J.J., Khoo, S.H., and Hierholzer, J.C. (1998) Adenoviruses from HIV-infected patients, including two new candidate serotypes Ad50 and Ad51 of Subgenus D and B1 respectively. In preparation.
- Eisenlohr, L.C., Gerard, W., and Hackett, C.J. (1987). Role of receptor-binding activity of the viral hemagglutinin

molecule in the presentation of influenza virus antigens to helper T-cells. *J. Virol* 61, 1375-1383

Eiz B and Pring-<sup>o</sup>kerblom P., 1997. Molecular characterization of the type-specific g-determinant located on the adenovirus fiber. *Journal of Virology* 71: 6576-6581.

Francki, R.I.B., Fauquet, C.M., Knudson, D.L. and Brown, F. (1991) Classification and nomenclature of viruses. Fifth report of the international Committee on taxonomy of viruses. *Arch. Virol. Suppl.* 2, 140-144

GahËry-SËgard H., Farace F., Godfrin D., Gaston J., Lengagne R., Tursz T., Boulanger P. and Guillet J., 1998. Immune response to recombinant capsid proteins of adenovirus in humans: antifiber and anti-penton base antibodies have a synergistic effect on neutralizing activity. *Journal of Virology* 72: 2388-2397.

Gall J., Kass-Eisler A., Leinwand L. and Falck-Pedersen E., 1996. Adenovirus type 5 and 7 capsid chimera: fiber replacement alters receptor tropism without affecting primary immune neutralization epitopes. *Journal of Virology* 70 (4): 2116-2123.

Greber, U.F., Willems, M., Webster, P., and Helenius, A. (1993). Stepwise dismantling of adenovirus 2 during entry into cells. *Cell* 75, 477-486.

Hynes, R.O. (1992) Integrins: versatility, modulation and signalling in cell adhesion. *Cell* 69, 11-25

Herz and Gerard, *Proc. Natl. Acad. Sci. U.S.A.*, 96 (1993):2812-2816

Hierholzer, J.C. (1992) Adenovirus in the immunocompromised host. *Clin. Microbiol Rev.* 5, 262-274.

Hierholzer, J.C., Wigand, R., Anderson, L.J., Adrian, T., and Gold, J.W.M. (1988) Adenoviruses from patients with AIDS: a plethora of serotypes and a description of five new serotypes of subgenus D (types 43-47). *J. Infect. Dis.* 158, 804-813.

Ishibashi, M. and Yasue (1983) in *Adenoviruses of Animals*, Chapter 12, p497-561

Kay, R., Takei, F., and Humphries, R.K. (1990). Expression cloning of a cDNA encoding M1/69-J11d heat-stable antigens. *J. Immunol.* 145 (6), 1952-1959

Khoo, S.H., Bailey, A.S., De Jong, J.C., and Mandal, B.K. (1995). Adenovirus infections in human immunodeficiency virus-positive patients: Clinical features and molecular epidemiology. *J. Infect. Dis.* 172, 629-637

Kidd, A.H., Chrboczek, J., Cusack, S., and Ruigrok, R.W. |H. (1993) Adenovirus type 40 virions contain two distinct fibers. *Virology* 192, 73-84.

Krasnykh V.N., Mikheeva G.V., Douglas J.T. and Curiel D.T., 1996. Generation of recombinant adenovirus vectors with modified fibers for altering viral tropism. *Journal of Virology* 70(10): 6839-6846.

Krasnykh V., Dmitriev I., Mikheeva G., Miller C.R., Belousova N. and Curiel D.T., 1998.

Characterization of an adenovirus vector containing a heterologous peptide epitope in the HI loop of the fiber knob. *Journal of Virology* 72(3): 1844-1852.

Leopold, P.L., Ferris, B., Grinberg, I., Worgall, S., Hackett, N.R., and Crystal, R.G. (1998). Fluorescent virions: Dynamic tracking of the pathway of adenoviral vectors in living cells. *Hum. Gene Ther.* 9, 367-378.

Levrero, M., Barban, V., Manteca, S., Ballay, A., Balsamo, C., Avantiaggiata, M.L., Natoli, G., Skellekens, H., Tiollais, P., and Perricaudet, M. (1991). Defective and non-defective adenovirus vectors for expression foreign genes in vitro and in vivo. *Gene* 101, 195-202.

Matlin, K.S., Reggio, H., Helenius, A., and Simons, K. (1981). Infectious entry pathway of influenza virus in a canine kidney cell line. *J. Cell Biol.* 91, 601-613

Morgan, C., Rozenkrantz, H.S., and Mednis, B. (1969). Structure and development of viruses as observed in the electron microscope. X. Entry and uncoating of adenovirus. *J. Virol* 4, 777-796.

Roest, P.A.M., Bout, M., van der Tuijn, A.C., Ginjaar, I.B., Bakker, E., Hogervorst, F.B.L., van Ommen, G-J. B., den Dunnen, J.T. (1996). *J. Med. Genet.* 33, 935-939.

Roest P.A.M., van der Tuijn, A.C., Ginjaar, I.B., Hoeben, R.C., Hogervorst, F.B.L., Bakker, E, den Dunnen, J.T. van Ommen, G-J. B. (1996). *Neuromusc. Disord.* 6 (no. 3), 195-202.

Roest P.A.M., van der Tuijn, A.C., Ginjaar, I.B., Hoeben, R.C., Hogervorst, F.B.L., Bakker, E, den Dunnen, J.T. van Ommen, G-J. B. (1999). *Lancet* 353, 727-728.

Richman, D.D., Hostetler, K.Y., Yazaki, P.J., and Clark, S. (1986). Fate of influenza A virion proteins after entry into subcellular fractions of LLC cells and the effect of amantadine. *Virology* 151, 200-210

Stevenson S.C., Rollence M., White B., Weaver L. and McClelland A., 1995.

Human adenovirus serotypes 3 and 5 bind to two different cellular receptors via the fiber head domain. *Journal of Virology* 69(5): 2850-2857.

Stevenson S.C., Rollence M., Marshall-Neff J. and McClelland A., 1997. Selective targeting of human cells by a chimaeric adenovirus vector containing a modified fiber protein. *Journal of Virology* 71(6): 4782-4790.

Signas, G., Akusjarvi, G., and Petterson, U. (1985). Adenovirus 3 fiberpolypeptide gene: Complications for the structure of the fiber protein. *J. Virol.* 53, 672-678.

Stouten, P.W.F., Sander, C., Ruigrok, R.W.H., and Cusack, S. (1992) New triple helical model for the shaft of the adenovirus fiber. *J. Mol. Biol.* 226, 1073-1084.

Schulick, A.H., Vassalli, G., Dunn, P.F., Dong, G., Rade, J.J., Zamarron, C. and Dichek, D.A. (1997). Established immunity precludes adenovirus-mediated gene transfer in rat carotid arteries.

Schnurr, D and Dondero, M.E. (1993) Two new candidate adenovirus serotypes *Intervirology*. 36, 79-83

Svensson, V. and Persson, R. (1984). Entry of adenovirus 2 into HeLa cells. *J. Virol.* 51, 687-694.

Varga, M.J., Weibull, C., and Everitt, E. (1991). Infectious entry pathway of adenovirus type 2. *J. Virol* 65, 6061-6070.

Wickham T.J., Carrion M.E. and Kovesdi I., 1995. Targeting of adenovirus penton base to new receptors through replacement

of its RGD motif with other receptor-specific peptide motifs.  
Gene Therapy 2: 750-756.

Wickham T.J., Segal, D.M., Roelvink, P.W., Carrion M.E.,  
Lizonova, A., Lee, G-M., and Kovesdi, I. (1996). Targeted  
adenovirus gene transfer to endothelial and smooth muscle  
cells by using bispecific antibodies. J. Virol. 70 (10),  
6831-6838

Wickham, T.J., Mathias, P., Cherish, D.A., and Nemerow, G.R.  
(1993) Integrins avb3 and avb5 promote adenovirus  
internalisation but not virus attachment. Cell 73, 309-319

Table 1

Subgroup	serotypes	hemagglutination rhesus	hemagglutination rat
A	12, 18, 31	-	+/-
B	3, 7, 11, 14, 16, 21, 34, 35, 51	+	-
C	1, 2, 5, 6	-	+/-
D	8-10, 13, 15, 17, 19, 20, 22-30, 32, 33, 36-39, 42-47, 49, 50	+/-	+
E	4	-	+/-
F	40, 41	-	+/-

Table 2

<u>Syndrom</u>	<u>Subgenus</u>	<u>Serotype</u>
Respiratory illness	A	31
	B	3, 7, 11, 14, 21, 34, 35, 51
	C	1, 2, 5, 6
	D	39, 42-48
	E	4
Keratoconjunctivitis (eye)	B	11
	D	8, 19, 37, 50
Hemorrhagic cystitis (Kidney)	B	7, 11, 14, 16, 21, 34, 35
	C	5
And urogenital tract infections	D	39, 42-48
	C	2
Sexual transmission	D	19, 37
	C	2
Gastroenteritis	A	31
	B	3
	C	1, 2, 5
	D	28
	F	40, 41
CNS disease	A	12, 31
	B	3, 7
	C	2, 5, 6
	D	32, 49
Hepatitis	A	31
	C	1, 2, 5
Disseminated	A	31
	B	3, 7, 11, 21
	D	30, 43-47
None (???)	A	18
	D	9, 10, 13, 15 17, 20, 22-29, 33, 36, 38

Table 3

Serotype	Tail oligonucleotide	Knob oligonucleotide
4	A	1
8	B	2
9	B	2
12	E	3
16	C	4
19p	B	2
28	B	2
32	B	2
36	B	2
37	B	2
40-1	D	5
40-2	D	6
41-s	D	5
41-1	D	7
49	B	2
50	B	2
51	C	8

A: 5'- CCC GTG TAT CCA TAT GAT GCA GAC AAC GAC CGA CC- 3'

B: 5'- CCC GTC TAC CCA TAT GGC TAC GCG CGG- 3'

C: 5'- CCK GTS TAC CCA TAT GAA GAT GAA AGC- 3'

D: 5'- CCC GTC TAC CCA TAT GAC ACC TYC TCA ACT C- 3'

E: 5'- CCC GTT TAC CCA TAT GAC CCA TTT GAC ACA TCA GAC- 3'

1: 5'- CCG ATG CAT TTA TTG TTG GGC TAT ATA GGA - 3'

2: 5'- CCG ATG CAT TYA TTC TTG GGC RAT ATA GGA - 3'

3: 5'- CCG ATG CAT TTA TTC TTG GGR AAT GTA WGA AAA GGA - 3'

4: 5'- CCG ATG CAT TCA GTC ATC TTC TCT GAT ATA - 3'

5: 5'- CCG ATG CAT TTA TTG TTC AGT TAT GTA GCA - 3'

6: 5'- GCC ATG CAT TTA TTG TTC TGT TAC ATA AGA - 3'

7: 5' - CCG TTA ATT AAG CCC TTA TTG TTC TGT TAC ATA AGA A - 3'

8: 5'- CCG ATG CAT TCA GTC ATC YTC TWT AAT ATA - 3'

Table 4

Adenovirus	Virus particles/ ml	Infectious units/ ml
Ad5Fib5	$2.2 \times 10^{12}$	$6.8 \times 10^{11}$
Ad5Fib12	$4.4 \times 10^{12}$	$1.9 \times 10^{12}$
Ad5Fib16	$1.4 \times 10^{12}$	$3.0 \times 10^{10}$
Ad5Fib17	$9.3 \times 10^{11}$	$9.5 \times 10^9$
Ad5Fib28	$5.4 \times 10^{10}$	$2.8 \times 10^8$
Ad5Fib32	$2.0 \times 10^{12}$	$1.1 \times 10^{12}$
Ad5Fib40-S	$3.2 \times 10^{10}$	$1.0 \times 10^{10}$
Ad5Fib40-L	$2.0 \times 10^{12}$	$6.4 \times 10^{11}$
Ad5Fib49	$1.2 \times 10^{12}$	$4.3 \times 10^{11}$
Ad5Fib51	$5.1 \times 10^{12}$	$1.0 \times 10^{12}$

Table 5

Cellline	Ad5Fiber5	Ad5Fiber12	Ad5Fiber1	Ad5Fiber28	Ad5Fiber32	Ad5Fiber40-S	Ad5Fiber40-L	Ad5Fiber49	Ad5Fiber51
A549	54186	2	283339	3556	46635	84562	407130	2	18337
K562	1	5	109688	7915	30958	1086	1907	1524	172569
SiG11	3926082	606032	14553005	855043	80834	ND	866546	77	1266653
Gm09503	506	4	117094	1858	39652	52759	609	4	1065309
1° chondrocytes	75	147	1026757	203114	9756	ND	1688026	49	1512035
1° Amnionvilli	8420131	4975463	6991792	37512	3313879	ND	5250524	4081	5785404
HEPG2	10861240	11428921	19315715	962463	3844661	ND	90713451	23894	8003123
HeLa	6638148	510784	776984	13571	15600	1551397	1694919	103	163415
CEM	93	6	1600	0	69	9	18	6.5	53
Synovocytes	103	ND	9936417	ND	ND	ND	ND	ND	ND
Smooth muscle cells	19019	664	816381	621	ND	ND	38632	ND	ND

Table 6

Cellline	a <sub>v</sub> β3	a <sub>v</sub> β5	CAR	MHC class I	subgroup A Ad5Fiber12	Subgroup B Ad5Fiber16	Subgroup C Ad5Fiber5	Subgroup D Ad5Fiber 32	Subgroup F Ad5Fiber40-L
AS49	17%	98%	100%	ND	Low	High	High	High	High
K562	12%	55%	0%	15%	Low	High	Low	High	High
GM09503	20%	50%	0%	100%	Low	High	Low	High	Low
CEM	0%	0%	3%	100%	Low	High	Low	High	High
SupT1	5%	1%	70%	100%	High	High	High	High	High
Smooth muscle cells	100%	70%	0%	15%	Low	High	Low	ND	Low
HUVEC	100%	15%	10%	80%	ND	High	Low	ND	ND
Synoviocytes	30%	40%	0%	100%	ND	High	Low	ND	ND
1'chorionvilli	100%	0%	12%	100%	Low	High	Low	Low	High
HepG2	0%	10%	100%	80%	High	High	High	High	High



or both; and  
iii) an adenovirus of subgroup B or D;  
and wherein said second adenovirus serotype is an adenovirus  
of subgroup B.

5

4. A recombinant vector according to claim 3, comprising a  
gene sequence encoding said fiber protein, wherein the gene  
sequence encoding at least the knob domain of a fiber  
protein of the second adenovirus further encodes a tall  
10 region of a fiber of the first adenovirus serotype.

5. A recombinant vector according to claim 3 or 4, which  
is a plasmid.

15 6. A kit of parts comprising a recombinant vector  
according to any one of claims 3 to 5 and a packaging cell  
providing in trans all elements necessary for adenovirus  
production not present on said recombinant vector, whereby  
there is essentially no overlap between said cell and said  
20 recombinant vector, leading to recombination resulting in  
the production of replication competent adenovirus.

7. A recombinant vector according to any one of claims 3  
to 5, where the insertion sites are different and preferably  
25 unique restriction sites.

8. A method for producing a chimaeric adenovirus having a  
desired host range and selected immunogenic properties,  
comprising:

30 - providing a recombinant vector according to any one of  
claims 3 to 5;  
- transfecting said recombinant vector in a packaging cell  
providing in trans all elements necessary for adenovirus  
production not present on said recombinant vector, whereby  
35 there is essentially no overlap between said cell and said  
recombinant vector, leading to recombination resulting in  
the production of replication competent adenovirus; and

- 75 -

- allowing for production of chimaeric adenoviruses.

9. A method according to claim 8, wherein said immunogenic  
5 antibodies.

10. A chimaeric adenovirus according to claim 1 or 2,  
wherein hexon, penton and/or fiber proteins are chimaeric  
10 proteins originating from different adenovirus serotypes.

11. A nucleic acid library comprising a collection of  
recombinant vectors according to any one of claims 3 to 5.

12. A chimaeric adenovirus according to any one of claims  
15 1, 2 or 10, a recombinant vector according to any one of  
claims 3 to 5 or 7, a kit according to claim 6, a method  
according to any one of claims 8 or 9 or a nucleic acid  
library according to claim 11 substantially as hereinbefore  
described with reference to the Figures and/or Examples.

20

DATED this 2<sup>nd</sup> day of July, 2003

**Introgene B.V.**

By DAVIES COLLISON CAVE

Patent Attorneys for the Applicants

25

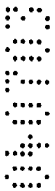

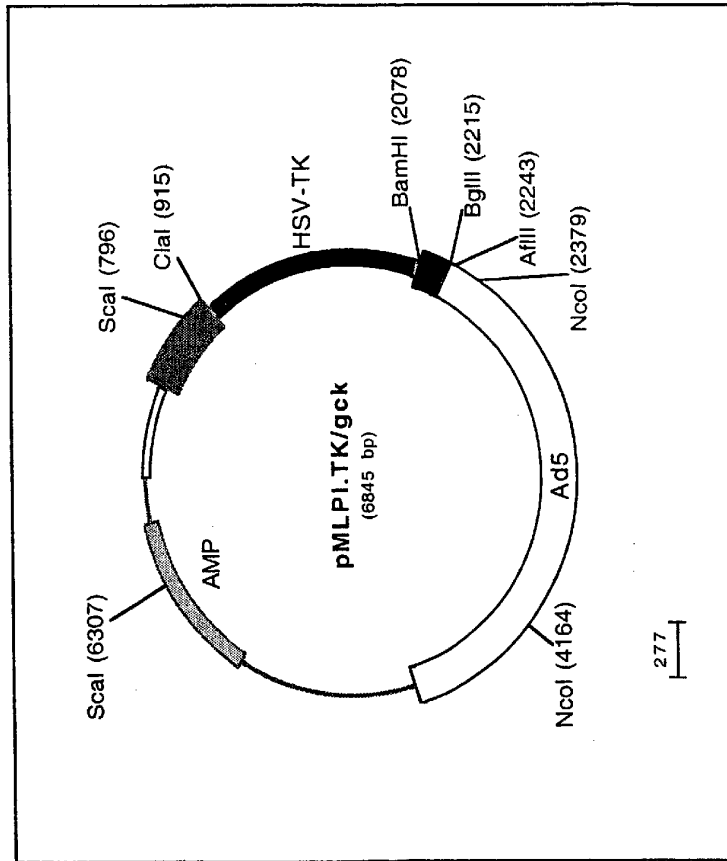
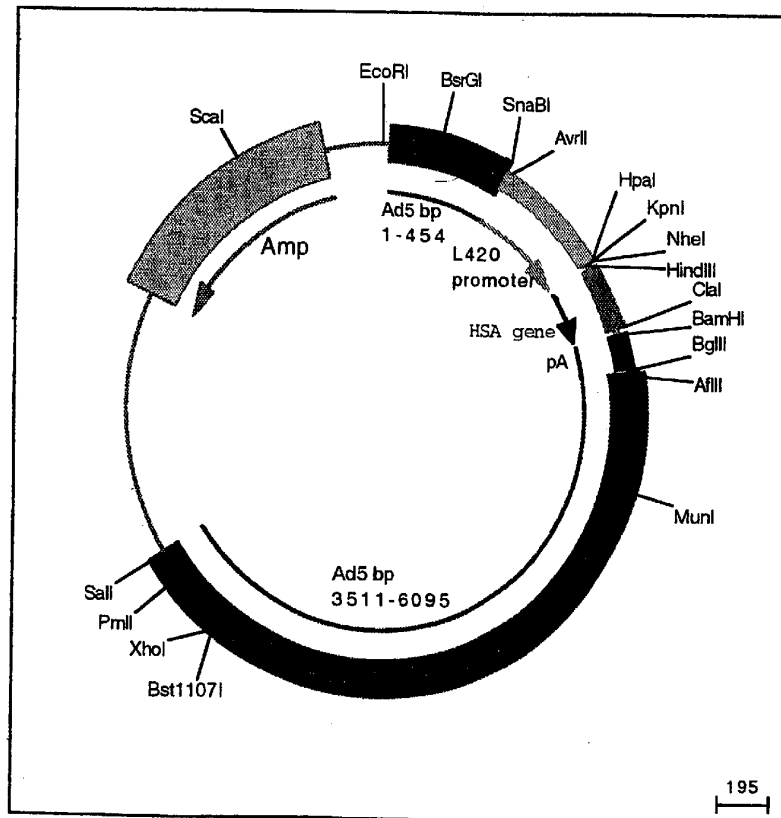

Figure 1

Figure 2



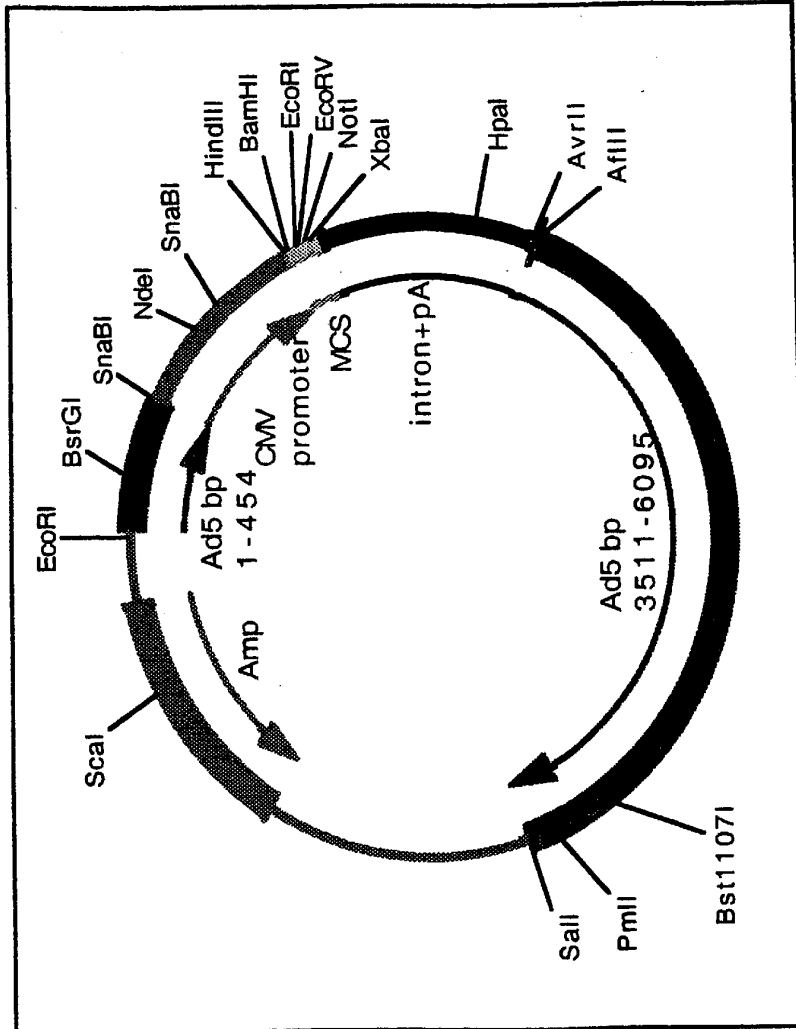

Figure 4

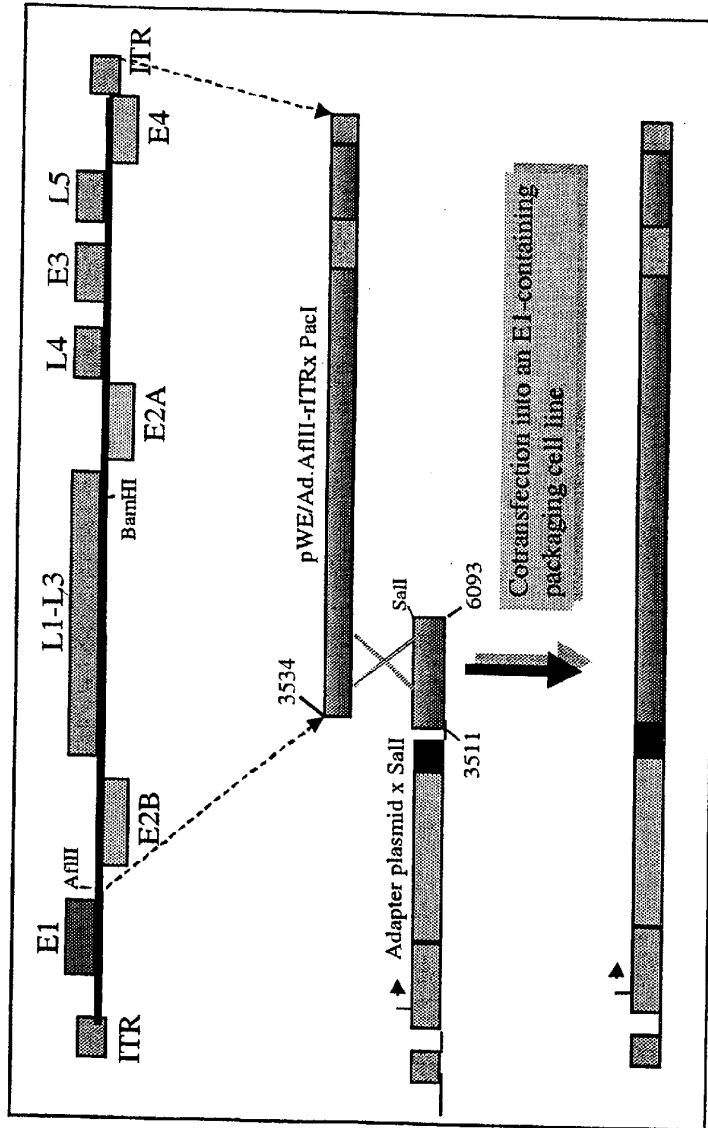
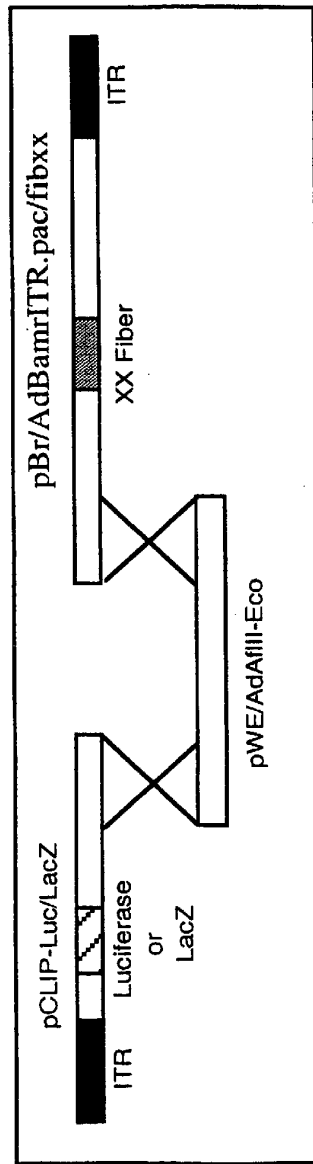

Figure 5



**Figure 6**

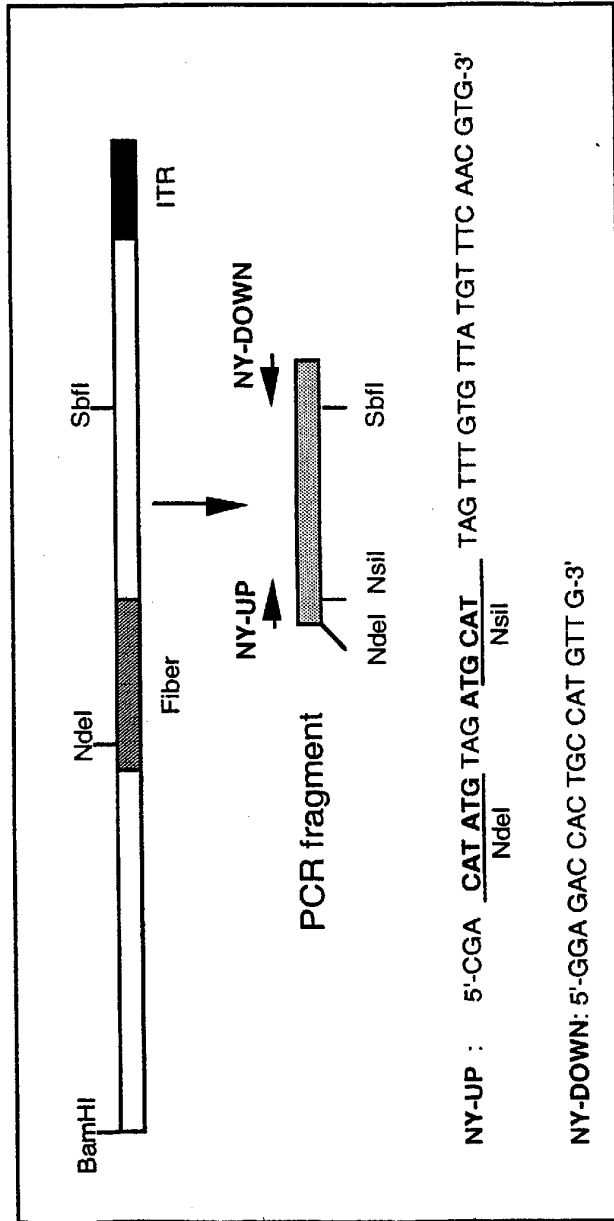

Figure 7:

## 1.1: Serotype 8 fiber protein

**SCSCPSAPTIFMLLQMKRARPSEDTFNPVYPYGYARNQNIPFLTTPPFVSSNGFQ  
 NFPPGVLSLKLADPITINNQNVS LKVG GGLTLQEBTGKLTVNTEPPLHLTNNKLG I  
 ALDAPFDVIDNKLTL LAGHGLSIITKETSTLPGLVNTLVVLTGKGIGTDLSNNGGN  
 ICVRV GEGGGLSFNDNGDLVAFNKKEDKRTLWTPDTS PNCRIDQDKD SKLTLV  
 LTKCGSQILANVSLIVVAGRYKIINNNTNPALKGFTIKLLFDKNGVLMESSNLGKS  
 YWNFRNQNSIMSTA YEKAIGFMPNLVA YPKPTTGSKKYARDIVYGNIYLGCKPH  
 QPVTIKTTFNQETGCEYSITFDFSWAKTYVNVVEFETTSFTFSYIAQE.**

## 1.2: Serotype 9 fiber protein

**SCSCPSAPTIFMLLQMKRARPSEDTFNPVYPYGYARNQNIPFLTTPPFVSSDGFQ  
 NFPPGVLSLKLADPIAVNGNVSLKVG GGLTLQDGTGKLTVNADPPLQLTNNKL  
 GIALDAPFDVIDNKLTL LAGHGLSIITKETSTLPGLINTLVVLTGKGIGTES TDNGG  
 SVCVRV GEGGGLSFNNDGDLVAFNKKEDKRTLWTPDTS PNCIDQDKD SKLTL  
 VLTCKGSQILANVSLIVVAGRYKIINNNTQPALKGFTIKLLFDENGVLMESSNLGK  
 SYWNFRNENSIMSTA YEKAIGFMPNLVA YPKPTAGSKKYARDIVYGNIYLGCKP  
 DQPVTIKTTFNQETGCEYSITFDFSWAKTYVNVVEFETTSFTFSYIAQE.**

## 1.3: Serotype 13 fiber protein

**XXXXXSAPTIFMLLQMKRARSSXDTFNPVYPYGYARNQNIXFXTPPFVXS DGF  
 KNFPPGVLSLKLADPITIANGDVSLKVG GGLTLQEGSLTVDPKAPLQLANDK KLE  
 LVYDDPFVSTNKL SLKVG HGLKVLDDKSAGGLKDLIGKLVVLTGKGIGIENLQ  
 NDDGSSRGVGINVRLGTDGGLSFDRKGELVAWNRKDDRRTLWTPDPSPNCKA  
 ETEKDSKLT LVTCKGSQILATVSIIVLKGKYE FVKKETEPKSFV KLLFDSKGV  
 LPTSNLSKEYWNYRSYDNIGTPYENA VPFMPNLKAYPKPTKTASDKAENKISS  
 AKNKIVSNFYFGQA YQPGTIIKFNEEIDETCAYSITFNFGWGKVYDNPFPD TTS  
 FTXSYIAQE.**

## 1.4: Serotype 14 fiber protein

**HPFINPGFISPNGFTQSPDGVLT LKCLTPLTTGGSLQLKVG GGLTVDDTDGTLQE  
 NIGATITPLVKTGH SIGLSL GAGLGTDENKLC TKLGEGLTFNSNNICIDDNINTLWT  
 GVNPT EANCQMDSSESNDCKLILTLVKTGALVTA FVYVIGVSNNFNMLT TYRN  
 INF T AELFFDSAGNLLTSLSSLKTPLNHKSGQTWLLVPLMLK VSCPAQLLILSIHL  
 EKNKTTFTTEL VTTQLVITLLFPLTISVMLNQR AIRADTSY CIRITWSWNTGDAPEG  
 QTSATTLVTS**

## 1.5: Serotype 20 fiber protein

**IQNIPFLTTPPFVSSDGLQNFPPGVLSLKLADPIAVNGNVSLKVG GGITVEQDSGQL  
 IANPKAPLQVANDKLELSYAYPFETSANKLSLKVGGGLKVLDEKDSGGLQNL LG  
 LKLVLTGKGIGVEELKNPDNTNRGVGINVRLGKDGGLSFNKN GELVAWNRKHND**

8/16

Figure 7 cont.

TGTLWTTDPSPNCKIEEVKDSKLTVLTKCGSQILATMAFQVVKGTYENISKNT  
AKNSFSIKLLFDDNGKLEGGSSLDKDYWNFRSDDSIIPNQYDNAVPFMPNLKAYP  
KPSTVLPSTDKNSNGKNTIVSNLYLEGKAYQPVAVTITFNKEIGCTYSITFDGWA  
KTYDVPPIFDSSSFT

1.6: Serotype 23 fiber protein

QNIPFLTTPPFVSSDGFQNFPPGVLSLKLADPIAITNGDVSLKVGGLTVEQDSGNL  
KVNTKAPLQVAADKQLEIALADPFVSKGRLGIKAGHGLKVIDNSISGLEGLVGT  
LVVLTGHGIGTENLLNNDGSSRGVGINVRLGKDGGLSFDKKGDLVAWNKKYDT  
RTLWTTDPSPNCKVIEAKDSKLTVLTKCGSQILANMSLLILKGTYEYISNAIAN  
KSFTIKLLFNDKGVLMGSSLDKDYWNYKSDSVMSKAYENAVPFMPNLKAYP  
NPTTSTTNPSTDKKSNGKNAIVSNVYLEGRAYQPVAITITFNKETGCTYSMTFDF  
GWSKVYNDPIPFDTSSLT

1.7: Serotype 24 fiber protein

SCSCPSAPTIFMLLQMKRARSEDTFNPVYPYGYARNQNIPFLTTPPFVSSDGFQ  
NFPPGVLSLKLADPIAITNGDVSLKVGGLTVEKDSGNLKVNPAPLQVTTDKQL  
EIALAYPFVSNKGLGIKAGHGLKVIDKIAGLEGLAGTLVVLTGKIGTENLENS  
DGSSRGVGINVRLAKDGGLSFDKKGDLVAWNKHDDRRTLWTTDPSPNCTIDQ  
ERDSKLTVLTKCGSQILANVSLVVKGKFSNINNTNPTDKKTTVKLLFNEKGV  
LMDSSILKKEYWNYRNDNSTVSQAYDNAVPFMPNKA YPKPTDTSAPEDKK  
SAAKRYIVSNVYIGGLPDKTVVITIKFNAETECAYSITFEFTWAKTFEDVQFDSSSF  
TFSYIAQE.

1.8: Serotype 25 fiber protein

SCSCPSAPTIFMLLQMKRARSEDTFNPVYPYGYARNQNIPFLTTPPFVSSDGFQ  
NFPPGVLSLKLADPITISNGDVSLKVGGLTVEQDSGNLSVNPAPLQVGTDKKL  
ELALAPPFNVKDNKLDLLVGDGLKVIDKXISLPLGLNLYVLTGKIGNEELKN  
DDGSNKGVLGCVRIGEGGLTFDDKGYLVAWNKKHDIRTLWTTLDPSNCRID  
VDKDSKLTVLTKCGSQILANVSLVVKGRFQNLNYPNPLPKTFTIKLLFDEN  
GILKSSNLDKNYWNYRNGNSILAEQYKNAVGFMPNLAA YPKSTTTQSKLYAR  
NTIFGNLYLDSQAYNPVVIKIFNQEADSAYSITLNYSWGKDYENIPFDS

1.9: Serotype 27 fiber protein

IPFLTTPPFVSSDGFKNFPPGVLSLKLADPITITNGDVSLKVGGLVVEKESGKLSV  
DPKTPQLQVADNKLKELSYNAPFKVENDKLSLDVGHGLKVIGNEVSSLPLINKLV  
VLTGKIGTEELKEQNSDKIIGVGINVRARGGLSFDNDGYLVAWNPKYDITRLW  
TTPDTPSPNCKMLTKKDSKLTVLTKCGSQILGNVSLAVSGKYLNMTKDETGVKI  
ILLFDRNGVLMQESSLDKEYWNYRNDNNVIGTPYENAVGFMPNLVA YPKPTSA  
DAKNYSRSKIISNVYLKGLIYQPVIASFNQETTNGCVSISFDFTCSKDYTGQQF  
DVTSF

1.10: Serotype 28 fiber protein

SCSCPSAPTIFMLLQMKRARSEDTFNPVYPYGYARNQNIPFLTTPPFVSSDGFQ  
NFPPGVLSLKLADPITIANGDVSLKLGGLTVEKESGNLTVNPAPLQVASGQLE  
LAYSYPFDVKNNMLTLKAGHGLAVVTKDNTDLQPLMGTLVVLTGKIGGTGSA

9/16.

Figure 7 cont.

HGGTIDVRIGKNGSLAFDKNGDLVAWDKENDRRTLWTPDTPSPCKMSEVKDS  
 KLTLTLTKCGSQILGSVSLAVKGEYQNMTASTNKNVKITLLFDANGVLEGGSS  
 DKEYWNFRNNDSTVSGKYENAVPFMPNITAYKPVNSKSYARSHIFGNVYIDAKP  
 YNPVVIKISFNQETQNNCVYSISFDYTCSEYTGMQFDVTSFTFSYIAQE.

1.11: Serotype 29 fiber protein

QNIPFLTTPPFVSSDGFKNPPGVLSLKLADPIAITNGDVSLKVGGGGLTVEQDSGNL  
 SVNPKAPLQVGTDKKLELALAPPFDVRDNKLAILVGDGLKVIDRSISDLPGLLNY  
 LVVLTGKGIGNEELKNDGSGNKGVGLCVRIGEGGGLTFDDKGYLVAWNNKHDI  
 RTLWTTLDPSNCKIDIEKSKLTLVLTCKGSQILANVSLIIVNGKFKILNNKTDPS  
 LPKSFNIKLLFDQNGVLENSNIEKQYLNFRSGDSILPEPYKNAIGFMPNLLAYAK  
 ATTDQSKIYARNTIYGNIYLDNQPYNPVVIKITFNNEADSAYSITFNYSWTKDYD  
 NIPFDSTSFTS

1.12: Serotype 30 fiber protein

SCSCPSAPTIFMLLQMKRARPSXDTFNPVYPYGYARNQNIPFXTPPFVSSDGFK  
 NPPGVLSLKLADPIAITNGDVSLKVGGGGLTVEQDSGNLSVNPKAPLQVGTDKK  
 LELALAPPFDVRDNKLAILVGDGLKVIDRSISDLPGLLNYLVVXTGKGIGNEELK  
 NDDGSGNKGVGLCVRIGEGGGLTXDDKGYLVAWNNKHDIRTLWTTLDPSNCKI  
 DIEKSKLTLVLTCKGSQILANVSLIIVNGKFKILNNKTDPSLPKSFNIKLLFDQNG  
 VLENSNIEKQYLNFRSGDSILPEPYKNAIGFMPNLLAYAKATTDQSKIYARNTIY  
 GNIYLDNQPYNPVVIKITFNNEADSAYSITFNYSWTKDYDNIPFDSTSFTFSYIAQE

1.13: Serotype 32 fiber protein

SCSCPSAPTIFMLLQMKRARPSXDTFNPVYPYGYARNQNIPFLTTPPFVSSDGFK  
 NPPGVLSLKLADPIAITANGNVSLKVGGGGLTVEQDSGKLIVNPKAPLQVANDKLE  
 LSYADPFETSANKLSLKVGHGLKVLDEKNAGGLKDLIGTLVLTGKGIGVEELK  
 NADNTNRGVGINVRLGKDGGLSFDKKGDLVAWNNKHDDRRTLWTTDPSPNCTI  
 DEERDSKLTTLVLTCKGSQILANVSLLVVKGKFSNINNTNPTDKKITVKLLFNEK  
 GVLMDSSSLKKEYWNYRNDNSTVSAQYDNAVPFMPNIKAYPKPTTDTSAKPED  
 KKSAAKRYIVSNVYIGGLPDKTVVITIKLNAETESAYSMTFEFTWAKTFENLQFD  
 SSSFTFSYIAQE.

1.14: Serotype 33 fiber protein

SCSCPSAPTIFMLLQMKRARPSXDTFNPVYPYGYARNQNIPFLTTPPFVSSDGFK  
 NPPGVLSLKLADPIAITNGDVSLKVGGGGLTVEQDSGLTVNPKAPLQLANDKKLEL  
 VYDDPFVSTNKLKSLKVGHGLKVLDDKSAGGLQDLIGKLVVLTGKGIGIENLQN  
 DDGSSRGVGINVRLGTDGGLSFDKKGELVAWNRKDDRRTLWTTDPSPNCKAE  
 TEKDSKLTTLVLTCKGSQILATVSIIVLKGKYEYFVKKETEPKSFVLLFDKGVLL  
 PTSNLSKEYWNYRSDNIGTPYENAVPFMPNLKAYPKPTKTASDKAENKISSA  
 KNKIVSNFYFGGQAYQPGTIIKFNNEIDETCAYSITFNFGWGKVDNPPFDTTSTF  
 TFSYIAQE.

1.15: Serotype 34 fiber protein

10/16

Figure 7 cont.

SCSCPSAPTIFMLLQMKRARPSEDTFNPVYPYEDESTSQHPFINPGFISPNGFTQ  
 SPDGVLTLKCLTPLTTGGSLQLKVGGLTVDDTDGTLQKNIRATTPITKNNHVS  
 ELTIGNLETQHNLCAKLGNGLKFNNGDICIKDSINTLWTGINPPPNCQIVENTN  
 TNDGKLTLLVVKNGGLVNGYVSLVGVSDTVNQMFQKTANIQLRLYFDSSGNL  
 LTDESCLKIPLKNKSSTATSETVASSKAFMPSTTAYPFNTTTRDSENYIHGICYYM  
 TSYDRSLFPLNISIMLNSRMISSNVAYAIQFEWNLNASESPEKQHMTLTTSPFFFSY  
 IEDDN.

1.16: Serotype 35 fiber protein

SCSCPSAPTIFMLLQMKRARPSEDTFNPVYPYEDESTSQHPFINPGFISPNGFTQ  
 SPDGVLTLKCLTPLTTGGSLQLKVGGLTVDDTDGTLQENIRATAPITKNNHVS  
 ELTIGNLETQNNKLCAKLGNGLKFNNGDICIKDSINTLWTGINPPPNCQIVENTN  
 TNDGKLTLLVVKNGGLVNGYVSLVGVSDTVNQMFQKTANIQLRLYFDSSGNL  
 LTESDLKIPLKNKSSTATSETVASSKAFMPSTTAYPFNTTTRDSENYIHGICYYM  
 TSYDRSLFPLNISIMLNSRMISSNVAYAIQFEWNLNASESPESNIMTLTTSPFFFSY  
 TEDDN.

1.17 Serotype 36 fiber protein

SCSCPSAPTIFMLLQMKRARPSEDTFNPVYPYGYARNQNIPFLTPPFVSSDGFK  
 NFPPGVLSLKLADPIAVNGDVSLKVGGLTVEQDSGKLVNPKIPLQVNDQLE  
 LATDKPFKIENKALDVGHLKVIDKTISDLQGLVGKLVVLTGVGIGTETLKDK  
 NDKVIGSAVNRLGKDGGLDFNKKGDLVAWNRYYDRRTLWTTPDPSPNCKVS  
 EAKDSKLTLLVTKCGSQLASVALLIVKGYQTISESTIPKQDRNFSVKLMFDEKQ  
 KLLDKSSLDKEYWNRFSNDSVVGTAAYDNAVPFMPNLKAYPKNTTSSNTPDDKI  
 SAGKKNIVSNVYLEGRVYQPVALTVKFNSENDCAYSITFDVFWSKTYESPVAFD  
 SSSFTFSYIAQE.

1.18 Serotype 37 fiber protein

SCSCPSAPTIFMLLQMKRARPSEDTFNPVYPYGYARNQNIPFLTPPFVSSDGFK  
 NFPPGVLSLKLADPITITNGDVSLKVGGLTLQDGS�TVNPKAPLQVNTDKKLEL  
 AYDNPFESSANKLSLKVGHGLKVLDEKSAAGLKDILGKLVVLTGKGIGTENLEN  
 TDGSSRGIGINVRAREGLTFDNDGYLVAWNPKYDLRTLWTTPDTPSPNCTIAQDK  
 DSKLTLLVTKCGSQLANVSLIVVAGKYHIINNKTNPKIKSFTIKLLFNKNGVLLD  
 NSNLGKAYWNRFSGNSNVSTAYEKAIGFMPNLVAVSKPSNSKKYARDIVYGNLY  
 LGGKPDQPGVIKTTFNQETGCEYSITFNFSWSKTYENVEFETTSFTFSYIAQE.

1.19 Serotype 38 fiber protein

SCSCPSAPTIFMLLQMKRARPSEDTFNPVYPYGYARNQNIPFXTPPFVXSDGFO  
 NFPPGVLSLKLADPITIANGNVSLKVGGLTLEQDSGKLVNXXKAPLQVANDKLE  
 LSYADPFETSANKLSLKVGHGLKVLDEKNAGGLKDILGTLVLTGKGIGVEELK  
 NADNTNRGVGINVRLGKDGGLSFDKKGDXVAWNKHDDRRRTLWTTPDPSPNCTI  
 DEERDSKLTLLVTKCGSQLANVSLVVKGKFSNINNTNPTDKKITVLLFNK  
 GVLMDSSSLKKEYWNYRNDNSTVSAAYDNAVPFMPNLKAYPKPTTDTSAKPED  
 KKSAAKRYIVSNVYIGGLPDKTVVITIKLNAETESAYSMITFEFTWAKTFENLQFD  
 SSSFTFSYIAQE.

## Figure 7 cont.

## 1.20 Serotype 39 fiber protein

IRISFSSLPPLSPPMDSKTSPLGCVHSNWLTSQSPSPMGMSHSRWEGGSPWQEGTG  
DLKVNAKSPLQVATNKQLEIALAKPFEEKDGKALKIGHGLAVVDENHHTLQSL  
IGTLVILTGKGIGTGRAESGGTIDVRLGSGGGLSFDKDGNLVAWNKDDRRRTLW  
TTPDPSPNCKIDQDKSKLTFVLTKCGSQILANMSLLVVKGKFSMINNKVNGTD  
DYKFKFTIKLLFDEKGVLLKDSLDKEYWNYRSNNNNVGSAYEEAVGFMPSTTA  
YPKPPTPTNPTTLEKSQAANKYVSNVYLGQAGNPVATTVSFNKETGCTYSIT  
FDFAWNKTyenVQC.

## 1.21: Serotype 42 fiber protein

SCSCPSAPTIFMLLQMKRARSEDTFNPVYPYGYARNQNPFLTPPFVSSDGFK  
NFPPGVLSLKLANPIAITNGDVSLKVGGLTLQDGTGKLTIDTKTPLQVANNKLE  
LAFDAPLYEKNGLALKTGHGLAVLTKDIGIPELIGSLVILTGKGIGTGVAGGGT  
IDVRLGDDGGLSFDKKGDLVAWNKKNDRRTLWTTDPDPSPNCRVSEDKSKLTLI  
LTKCGSQILASFSLLVXGTYTTVDKNTTNKQFSIKLLFDANGKLLKSESNSLGYW  
NYRSDNSVVSTPYDNAVPFMPNTTAYPKINSTTDPENKKSAAKKTIVGNVYLEG  
NAGQPVAVAISFNKETTADYSITFDFAWSKAYETPVFPDTSMTFSYIAQE.

## 1.22: Serotype 43 fiber protein

NIPXLTPPFVSSDGFKNFPPGVLSLKLADPITITNGDVSLKVGGLTVEKESGNLT  
VNPKAPLQVAKGQLELAYDSPFDVKNNMLTLKAGHGLAVVTKDNTDLQPLMG  
TLVLTGKGIGTGSAHGGTIDVRIGKNGSLAFDKGDLVAWDKENDRRRTLWT  
TPDTPSPNCKMSEAKDSKLTLLTKCGSQILGSVSLAVKGEYQNMANTKKNVKI  
TLLFDANGVLLAGSSXXKEYWNFNSNDSTVSGNYENAVQFMPNITAYKPTNSKS  
YARSVIFGNVYIDAKPYNPVVVIKISFNQETQNNCVYSISFDYTLISKDYPNMQFDV  
TLS

## 1.23: Serotype 44 fiber protein

NIPFLTPPFVSSDGFQNFPPGVLSLKLADPITITNGVSLKVGGLTLQEGTGDLK  
VNAKSPLQVATNKQLEIALAKPFEEKDGKALKIGHGLAVVDENHHTLQSLIGTL  
VILTGKGIGTGSAESGGTIDVRLGSGGGLSFDKDGNLVAWNKDDRRRTLWTTDP  
PSPNCKIDQDKSKLTFVLTKCGSQILANMSLLVVKGKFSMINNKVNGTDDYK  
FTIKLLFDEKGVLLKDSLDKEYWNYRSNNNNVGSAYEEAVGFMPSTTAYPKPP  
TPTNPTTLEKSQAANKYVSNVYLGQAGNPVATTVSFNKETGCTYSITFDFA  
WNKTYENVQFDSSF

## 1.24: Serotype 45 fiber protein

NIPFLTPPFVSSDGFQNFPPGVLSLKLADPIAITNGDVSLKVGGLTVEKDSGNLK  
VNPKAPLQVTTDKQLEIALAYPFVSNKGLGKAGHGLKVIDKIAGLEGLAGTLV  
VLTGKGIGTENLENSDGSRGVGINVRLAKDGVLAFDKKGDLVAWNKHDDRRT  
LWTTDPDPSPNCTIDQERDSKLTLLTKCGSQILANVSLVVKGKFSNINNNANPT  
DKKITVKLLFNEKGVLMDSSTLKKEYWNYRNDNSTVSQAYDNAVPFMPNIKAY  
PKPSTDTSAKPEDKKSAAKRYIVSNVYIGGLPDKTVVITIKFNAETECAYSITFEFT  
WAKTFEDVQCDSSSFT

## 1.25: Serotype 46 fiber protein

## Figure 7 cont.

NIPFLTPPFVSSDGFKNFPPGVLSLKLADPIAVNGDVSLKVGGGGLTQEGNLTVD  
 AKAPLQVANDNKLELSYADPFVVKDTKLQQLKVGHGLKVIDEKTSSGLQSLIGNL  
 VVLTGKGIGTQELKDKDDETKNIGVGINVRIGKNESLAFDKDGNLVAWDNENDR  
 RTLWTPDPTSSKFVKISTEKDSKLTVLTKCGSQILASVSLAVAGSYLNMTAST  
 QKSIVVSLMFDKGLMTTSSIDKGYWNYRNKNSVVGTAAYENAIFFMPNLVAYP  
 RPNTPDSKIYARSKIVGNVYLAGLAYQPIVITVSNQEKDASCAYSITFEFAWNKD  
 YVGQFDTTSFT

## 1.26 Serotype 47 fiber protein

SCPSAPTIFMLLQMKRARPSEDTFNPVYPYGYARNQIPFLTPPFVSSDGFKNF  
 PPGVLSLKLADPITTINGDVSLKVGGGGLTQEGTGNLTVNAKAPLQVADDDKLE  
 LSYDNPFEVSAANKLSLKVGHGLKVLDEKNSGGLQELIGKLVLTGKGIGVEELKN  
 ADNTNRGVGINVRLGKDGGLSFDKKGELVAWNKHNDRTLWTPDPSPNCKIE  
 QDKDSKLTVLTKCGSQILATMAFQVVKGTYENISKNTAKKSFSIKLLFDDNGKL  
 LEGSSLDKDYWNFRNDDSIMPNQYDNAVPFMPNLKAYPNPKTSTVLPSTDKKS  
 GNKTIVSNLYLEGGKAYQPVAVTITFNKETGCTYSITFEFGWAKTYDVPIPFDSSSF  
 TFSYIAQE.

## 1.27: Serotype 48 fiber protein

SDIPFLTPPFVSSDGFQNFPPGVLSLKLADPITTINGNVSLKVGGGGLTQEGTGDLK  
 VNAKSPLQVATNKLEIALAKPFEEKDGKLAALKIGHELAVVDENLTHLQSLIGTL  
 VILTKGIGTGRAESGGTIDVRLGSGGGLSFDKDGNLVAWNKDDRRRTLWTPD  
 PSPNCKIDQDKDSKLTFLTKCGSQILANMSLLVVKGKFSMINNKVNGTDDYKK  
 FTIKLLFDEKGVLLKDSLLDKEYWNYRSNNNNVGSAYEEAVGFMPSTTAYPKPP  
 TPPTNPTTPEKSAKKNKYVSNVYLGGAAGNPVATTVSFNKETGCTYSITFDFA  
 WNKTYKMAFIPRFNF

## 1.28: Serotype 49 fiber protein

SCSCPSAPTIFMLLQMKRARPSEDTFNPVYPYGYARNQIPFLTPPFVSSDGFQ  
 NFPPGVLSLKLADPIATNGNVSLKVGGGGLTVEQDSGNLKVNPAPLQVATDNQ  
 LEISLADPFVKNKLSLKVGHGLKVIDENISTLQGLLGNLVLVTGMGIGTEELK  
 KDDKIVGSAVNVRLQDGGGLTFDKKGDVAWNKENDRRRTLWTPDPSPNCKV  
 EEKDSKLTVLTKCGSQILASVSLLVVKGKFANINNKTNPGEDYKXFSVLLFDA  
 NGKLLTGSSLDGNYWNYKNKDSVIGSPYENAVPFMPNSTAYPKIINNGTANPED  
 KKSAAKKTIVTNVYLGGAAPVATTISFNKETESNCVYSITFDFAWNKTYKNV  
 PFDSSSLTFSYIAQE.

## 1.29.: Serotype 51 Fiber protein

SCSCPSAPTIFMLLQMKRARPSEDTFNPVYPYEDESTSQHPFINPGFISPNGETQ  
 SPDGVLTNLCLPLTTTGGPLQLKVGGGGLIVDDTDGTLQENIRVTAPITKNNHSV  
 ELSIGNLETQNNKLCAGLGNLKFNNGDICIKDSINTLWTGKPPPCQIVENTD  
 TNDGKLTVLVKNGLVNGYVSLVGVSDTVNQMFQKSATIQLRLYFDSGNNLL  
 TDESNLKIPLKNKSSATSEAATSSKAFMPSTTAYPFNTTTRDSENYIHGICYMT  
 SYDRSLVPLNISIMLNSRTISSNVAAYAIQFEWNLNAKESPESENIATLTTSPFFFSYIE  
 DTTKICISLCYVSTCLFFN

**Figure 8**

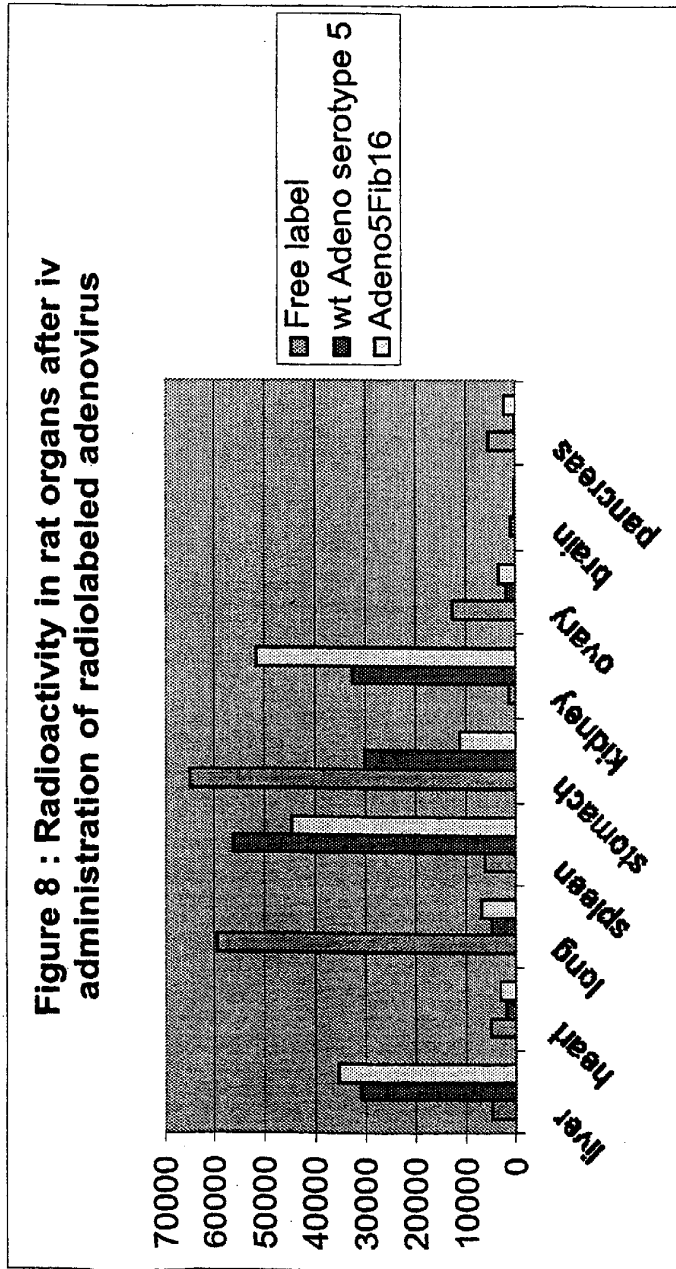
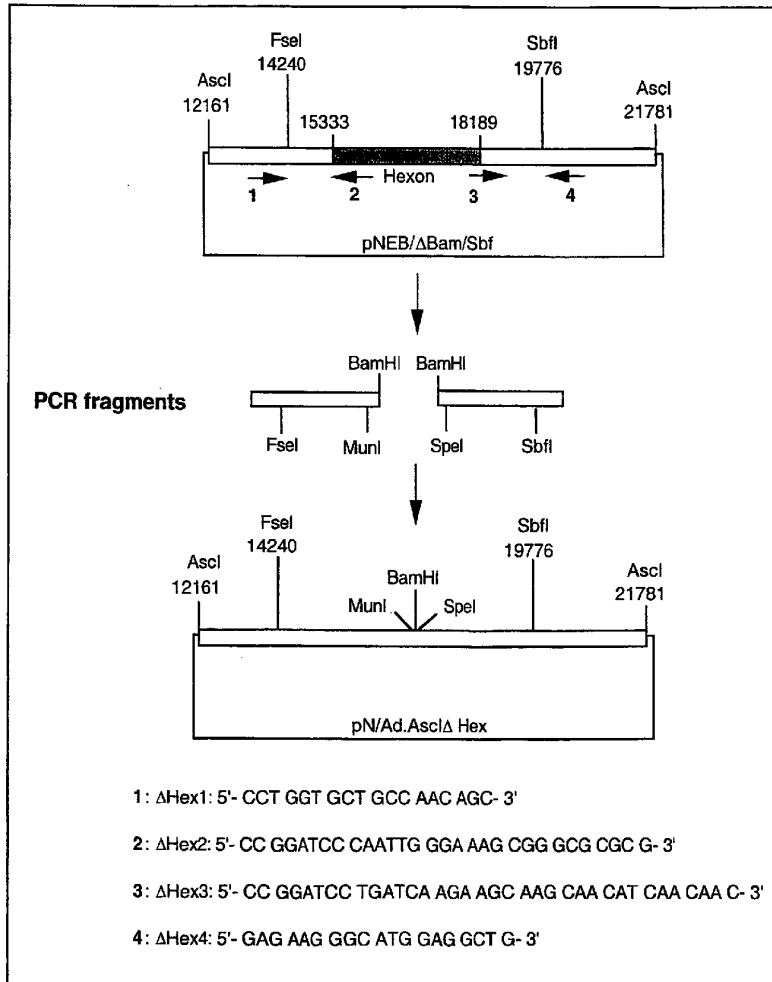

Figure 9



15/16

Figure 10

## 1.1: Serotype 34 hexon protein

LSRRAPGFPLVKMATPSMLPQWAYMHIAQDASEYLSPLGVQFARATDTYFNL  
 GNKFRNPTVAPTHDVTDRSQRLMLRFVVDREDNTYSYKVRITLA VGDNRVL  
 DMASTFFDIRGVLDGRPSFKPYSGTAYNSLAPKGAPNASQWLDKGVSTGLVDD  
 GNTDDGEEAKKATYTFGNAPVKA EAEITKDGLPVGLEVSTEGPKPIYADKLYQP  
 EPQVGDETWTDLDGKTEEYGG RVLKPKETKMKPCYGSFAKPTNIKGGQAKVKPK  
 EDDGTNNIEYDIDMNFDDLRSQRSELKPKIVMYAENVLECPDTHVYKPGVSD  
 ASSETNLGQQSMPNRPNYIGFRDNFIGLMYYNSTGNMGVLAGQASQLNAVVDL  
 QDRNTELSYQLLDSLDRTRYFSMWNQAVDSYDPDVRVIENHGVEDELPNYCF  
 PLDGVGPRTDSYKEIKPNGDQSTWTVNDPTGSSELAKGNPFAMEINLQANLWRS  
 FLYSNVALYLPDSYKYTPSNVTLPENKNTYDMNGRVVPPSLVDTYVNIGARWS  
 LDAMDNVNPFNHHRNAGLRYSMLLGNGRYVPFHIQVPQKFFAVKNLLLLPGS  
 YTYEWNFRKDVNMVQLSSLDLRVDGASISFTSINLYATFFPMAHNTASTLEA  
 MLRNDTNDQSFNDYLSAANMLYPIANATNIPISIPSRNWA AFRGWSFTRLKTKE  
 TPSLGS GFDPYFVYSGSIPLDGTFYLNHTFKKVSIMFDSSVSWPGNDRLLSPNEFEI  
 KRTVDGEGYNVAQC NMTDWFLVQLANYNIGYQGFYIPEGYKDRMYSFFRNF  
 QPMSRQVVDEVNYKDFKAVIPYQHNNNGFVGYMPTMRQQQPYPANYPYPLIG  
 TTAVNSVTQKKFLCDRTMWRIPFSSNFMSMGALTDLGQNMLYANSAHALDMTF  
 EVDPMDEPTLLYLLFEVFDVVRVQPHRGIEAVLRTPFSA GNATT.

## 1.2: Serotype 35 hexon protein

LSRRAPGFPLVKMATPSMLPQWAYMHIAQDASEYLSPLGVQFARATDTYFNL  
 GNKFRNPTVAPTHDVTDRSQRLMLRFVVDREDNTYSYKVRITLA VGDNRVL  
 DMASTFFDIRGVLDGRPSFKPYSGTAYNSLAPKGAPNASQWLDKGVSTGLVDD  
 GNTDDGEEAKKATYTFGNAPVKA EAEITKDGLPVGLEVSTEGPKPIYADKLYQP  
 EPQVGDTWTDLDGKTEEYGG RVLKPKETKMKPCYGSFAKPTNIKGGQAKVKPKE  
 DDGTNNIYDIDMNFDDLRSQRSELKPKIVMYAENVLECPDTHVYKPGVSDAS  
 SETNLGQQMPNRPNYIGFRDNFIGLMYYNSTGNMGVLAGQASQLNAVVDLQDR  
 NTELSYQLLDSLDRTRYFSMWNQAVDSYDPDVRVIENHGVEDELPNYCFPLDG  
 VGPRTDSYKEIPNGDQSTWTVNDPTGSSELAKGNPFAMEINLQANLWRSFLYSN  
 VALYLPDSYKYTPSNVTLPENKNTYDMNGRVVPPSLVDTYVNIGARWSLDAMD  
 NVNPFNHHRNAGRYRSMMLGNGRYVPFHIQVPQKFFAVKNLLLLPGSYTYEWN  
 FRKDVNMVQLSSLDLRVDGASISFTSINLYATFFPMAHNTASTLEAMLRNDTND  
 QSFNDYLSAANMLYPIANA TNPISIPSRNWA AFRGWSFTRLKTETPSLGS GFDP  
 YFVYSGSIPYLDGTFYLNHTFKKVSIMFDSSVSWPGNDRLLSPNEFEIKRTVDGEGY  
 NVAQC NMTKDWFLVQLANYNIGYQGFYIPEGYKDRMYSFFRNFQPMSRQVVDE  
 VNYKDFKAVAIPIYQHNNNGFVGYMPTMRQQQPYPANYPYPLIGTTAVNSVTQK  
 KFLCDRTMWRIPFSSNFMSALTDLGQNMLYANSAHALDMTFEVDPMDEPTLLY  
 LLFEVFDVVRVHQPHRGIEAVLRTPFSA GNATT.

## 1.3 Serotype 36 hexon protein

16/16

Figure 10 cont.

LSRRAPGFPLVKMATPSMLPQWAYMHIAGQDASEYLSPLGVQFARATDTYFNL  
 GNKFRNPTVAPTHDVTDRSQRLMLRFVVDREDNTYSYKVRVYTLAVGDNRLV  
 DMASTFFDIRGVLDRGPFKPYSGTAYNSLAPKGAPNASQWLDKGVSTGLVDD  
 GNTDDGEEAKKATYTFGNAPVKAEEITKDGLPVGLEVSTEGPKPIYADKLYQP  
 EPQVGDVTWDLGKTEEYGGRLKPKETKMKPCYGSFAKPTNIKGGQAKVKPKE  
 DDGTNNIYDIDMNFDDLRSQRSELKPKIVMYAENVLECPDTHVYKPGVSDAS  
 SETNLGQQSMPNRPNYIGFRDNFGLMYNSTGNMGVLAGQASQLNAVVDLQD  
 RNTELSYQLLDSLDRTRYFSMWNAVDSYDPDVRVIENHGVEDELPNYCFPLD  
 GVGPRDTSYKIKPNGDQSTWTVNDPTGSSELAKGNPFAMEINLQANLWRSFLYS  
 NVALYLPDSYKYTPSNVTLPENKNTYDYMNGRVVPPSLVDTYVNIGARWSLDA  
 MDNVNPFNHHRAGLRYRSMLLGNRYVFFHIQVPQKFFAVKNLLLLPGSYTYE  
 WNFREKDVNMVQLSLGNDLRVDGASISFTSINLYATFFPMAHNTASTLEAMLNRD  
 TNDQSFNDYLSAANMLYPIANATNIPISIPSRNWAAFRGWSFTRKTKETPSLGS  
 GFDPYFVYSGSIPYDGTFLNHTFKKVSIMFDSVSWPGNDRLLSPNEFEIKRTVD  
 GEGYNVAQCMTKWFLVQMLANYNIGYQGFYIPEGYKDRMYSFFRNFPQMSR  
 QVVDEVNYKDFKAVIYQHNSGFVGYMPTMRQGPYPANYPYPLIGTTAVNS  
 VTQKKFLCDRTMWRIPFSSNFMSMGALTDLGQNMLYANSAHALDITFEVDPM  
 DEPTLLYLLFEVFDVVRVQPHRGIEAVYLRTPFSAAGNATT.

## 1.4: Serotype 41 hexon protein

VCVHVAARGAAEPPRARFPLVKMATPSMMPQWAYMHIAGQDASEYLSPLGVQ  
 FARATDTYFSLGNKFRNPTVAPTHDVTDRSQRLTLRFVVDREDDTYSYKARFT  
 LAGDNRLVDMASTYFDIRGVLDRGPFKPYSGTAYNSLAPKGAPNSSQWADKE  
 RVNNGGNTKDVTKTFGVAAMGGEDITEKGLKIGTDTTANEPFADKNFQPEPQV  
 GEENQETVYFYGGRALKKETKMKPCYGSFARPTNEKGGQAKFIQDNGQPTENH  
 DITMAFDTPGGTITGGTGGPQDELKADIVMYTENINLETPTDTHVYKPGKEDDSS  
 EINLVQSMNRPNYIGFRDNFVGLMYNSTGNMGVLAGQASQLNAVVDLQDRN  
 TELS YQLLDSLDRTRYFSMWNSAVDSYDPDVRVIENHGVEDELPNYCFPLDGGG  
 TNSAFQGGKIKQNDGDVNDWEKDDKYSTQNQICKGNIYAMEINLQANLWKSF  
 LYSNVALYLDYKYTPANVTLPTNTNTYEMNGRVVAPSLVDAYINIGARWSLD  
 PMDNVNFNHRNAGLRYRSNASGQRPLRALPHSPAPKVLCHQEPAPAPGLLHLR  
 VELPQGRQHDAEFPRKPARRRRLRALRQRQLCHILPHGAQHRLHPGSHAAQR  
 HQRPVQLRPLRQHALPHPGQGHQRAHLHPLAQLGRLSRLEFHPAQDQNSFPR  
 LGFRPLLCLLGLHPLPRDLLPQPHLQEGLEHHVRLGQLARQRPVTPNEFEIKRS  
 VDGEYNVAQCMTKWFLVQMLSHYNIGYQGFHVPEGYKDRMYSFFRNFPQMSR  
 SRQVDEINYKDYAVTLPFQHNSGFYGLAPTMRQGPYPANFPYPLIGSTAVP  
 SVTQKKFLCDRTMWRIPFSSNFMSMGALTDLGQNMLYANSAHALDITFEVDPM  
 DEPTLLYLLFEVFDVVVHQPVRGIVIEAVYLRTPFSAAGNATT.