

(No Model.)

2 Sheets—Sheet 2.

J. HARPER & F. CLINGFAST.
COTTON PLANTER.

No. 524,760.

Patented Aug. 21, 1894.

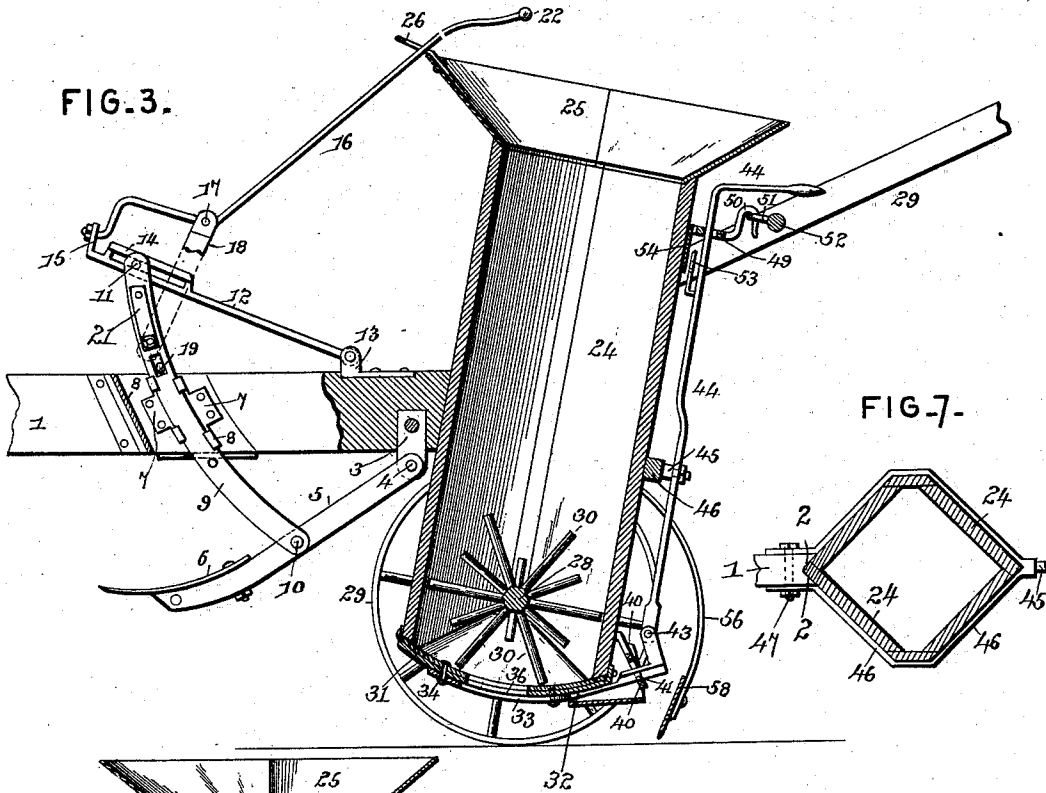

FIG. 7.

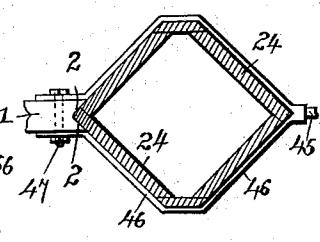

FIG. 4.

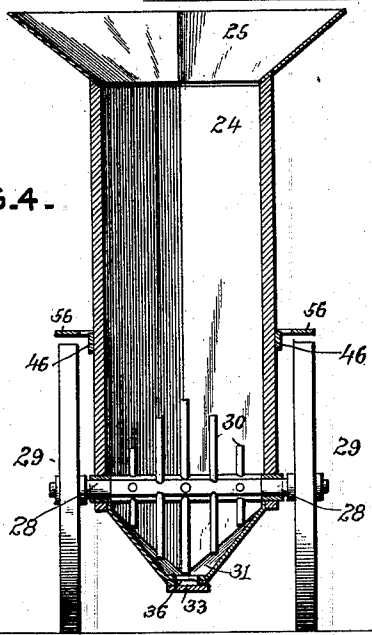
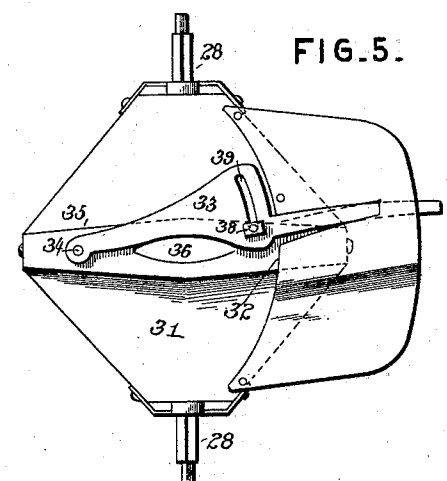

FIG. 5.



Witnesses
Jas. H. McLathran
M. S. Duwall

By their Attorneys,

Inventors
James Harper
Francis Clingfast
C. Snow & Co.

UNITED STATES PATENT OFFICE.

JAMES HARPER AND FRANCIS CLINGFAST, OF LA PILE, ARKANSAS.

COTTON-PLANTER.

SPECIFICATION forming part of Letters Patent No. 524,760, dated August 21, 1894.

Application filed December 1, 1893. Serial No. 492,492. (No model.)

To all whom it may concern:

Be it known that we, JAMES HARPER and FRANCIS CLINGFAST, citizens of the United States, residing at La Pile, in the county of Union and State of Arkansas, have invented a new and useful Cotton-Planter, of which the following is a specification.

Our invention relates to improvements in cotton-planters; the objects in view being to produce a cheap and simple machine adapted to plant cotton seed or distribute fertilizer, as desired, in drills; to form the furrow for the reception of the same; subsequently cover the deposit; and to regulate the amount of output or flow as desired.

A further object in view is to removably attach the planting-mechanism to the stock of the machine, whereby the latter may be employed as an ordinary plow; and finally to provide for a raising and lowering of the shovel-carrying standard, whereby the machine may be transmitted from field to field when necessary.

Other objects and advantages of the invention will appear in the following description and the novel features thereof will be particularly pointed out in the claims.

Referring to the drawings:—Figure 1 is a perspective view of a cotton-planter embodying our invention. Fig. 2 is a rear elevation of the same. Fig. 3 is a longitudinal sectional view. Fig. 4 is a transverse sectional view through the hopper. Fig. 5 is a bottom plan of the hopper. Fig. 6 is a detail perspective view of the adjusting devices for the drill forming plow. Fig. 7 is a horizontal section through the hopper to show the manner of fitting it to the beam.

Like numerals of reference indicate like parts in all the figures of the drawings.

In the practice of our invention we employ a stock or beam 1, which it will be understood is designed to be provided at its front end with suitable draft-devices, and the rear end of said beam is provided with a V-shaped notch 2 for the accommodation of the hopper hereinafter described. A bearing-lug 3 is secured upon the under side of the beam and embracing and pivoted to the same at 4 is a bifurcated plow-foot or standard 5 at the lower end of which there is adjustably mounted an ordinary drill-forming plow 6,

which may be of any desired style or construction. In the opposite sides of the beam or stock 1 we locate a pair of curved keeper-plates 7, and in front of the same a pair of fenders 8. In the keeper-plates 7 are loosely mounted the opposite curved braces or straps 9, whose lower ends are pivoted at 10 to the bifurcated standard and whose upper ends are connected by a cross-pin 11.

A lever 12 is pivoted between a pair of bearing-ears 13 located upon the upper side of the stock or beam in rear of the braces 9, and the said lever is provided at its front or free end with a horizontal guide-frame 14, through which transversely extends the pin 11 and in which said pin is designed to ride. Beyond this guide-frame the lever 12 has its front end upturned as at 15. Loosely connected to the front upturned end 15 is a handle 16, which extends upward and rearward and has pivoted as at 17 a brace 18, at whose lower end a bolt 19 is located and is secured to one of the braces 9 by a keeper 20. A flat spring 21 secured to an adjacent brace 9 presses the bolt inward, so that the same may be engaged under or over the beam in accordance with the position of the parts. The upper end of the handle 16 is shaped to form a grip 22, and by grasping the same and drawing the handle upward and withdrawing the bolt from engagement below the beam, the pivoted plow-standard may be elevated and the same locked in a raised position by the bolt engaging over the upper side of the beam or stock. On the other hand, by disengaging the bolt from the upper side of the beam and lowering the handle the stock may be lowered into operative position. When elevated it will be obvious that the machine may be supported loosely upon the wheels hereinafter described, and thus moved from one field to another without operating.

Located in the rear notched end 2 of the beam 1 is the vertically disposed hopper 24, and the same in cross-section is substantially rectangular and is provided at its upper end with the flared mouth 25, the same having a guide-eye 26 at its front corner to loosely receive and guide the handle 16, so that the latter at its upper end is always within easy reach of the operator. The hopper it will be seen extends above and below the beam and

is embraced by a pair of handles 27 which are secured to the opposite sides of the beam and extend in rear of the said hopper. A pair of bearings is formed in the opposite side corners of the hopper and through the same passes a transverse axle 28 upon which is mounted fixedly a pair of ground-wheels 29 located at opposite sides of the hopper. The intermediate portion of the hopper is provided with stirring-arms 30, which serve to agitate the cotton-seed within the hopper. The bottom 31 of the hopper is provided with opposite downwardly and inwardly inclined portions and has a central strap 35, which is provided with a discharge opening 36, and pivoted to the strap at 34, near the front end thereof, is a cutoff 33, which has its rear portion operating in a transverse slot or opening 32 of the bottom 31. The cutoff is capable of a limited transverse movement on the lower face of the strap to vary the size of the discharge opening 36, or to close the same entirely. The metal strap is provided with a headed lug 38, and the same extends through a segmental slot 39 formed in the cut-off and serves to guide the latter in its opening and closing movements.

A horizontal frame 40 is secured to the rear side of the hopper immediately above the bottom, and the lower bar of this frame is provided with a series of shallow notches 41. The cut-off extends through and beyond this frame, and has pivoted thereto, as at 43, the lower end of an operating-handle or lever 44 which is fulcrumed between its ends upon a stud 45 formed on the rear side of a hopper embracing strap 46 whose terminals are removably bolted as at 47 to the rear end of the beam or stock 1. The upper end of this lever is passed through a guide-frame 49 secured to the rear side of the hopper and the upper end thereof and which has its terminals 50 hook-shaped to engage keepers 51 located upon the cross-rung 52 that connects the handles 27. A pointer 53 is carried by the lever, and the same moves over a scale-plate 54 secured to the rear side of the hopper, and the latter is so graduated as to indicate the size of the discharge opening 36 and the amount of cotton-seed or fertilizer discharged per acre as the case may be.

A pair of curved spring-arms 56 are bolted to the under side of the beam 1, diverge at opposite sides of the hopper, and extend over the wheels, and depend in rear of the same, where they are connected by a transverse scraper-blade 58.

This completes the construction of the machine, and the simplicity of the same will be obvious from an inspection of the drawings in connection with the foregoing description.

It will be seen that in planting cotton-seed or distributing fertilizer, the drill or furrow is produced by the shovel and that a predetermined quantity of the cotton-seed or fertilizer is dropped continuously in the drill or furrow thus formed. This deposit is covered

by the scraper-plate or blade that follows in the wake of the same, so that as will be obvious we produce the drill, drop the cotton-seed or fertilizer, and cover the same all in one continuous, unbroken operation.

The operator may at any time regulate the outflow of the cotton-seed or fertilizer by a simple adjustment of the cut-off through the medium of the hand-lever at the back of the hopper, or may readily raise the plow so as to be brought to an inoperative position or lower the same to an operative position, and hence may travel from field to field.

If it be desired to use the device as an ordinary plow, this may be accomplished very readily by removing the spring-arms that support the scraper-blade or plate, together with the hopper and its connection, thus leaving merely the stock, the handles, the shovel and standard.

We do not limit our invention to the precise details of construction herein shown and described, but hold that we may vary the same to any degree and extent within the knowledge of the skilled mechanic.

Having described our invention, what we claim is—

1. The combination with a plow-beam provided at opposite sides with guides, of a plow-standard pivoted in rear of the guides, braces arranged for movement in the guides and pivoted at their lower ends to the plow-standard, a transverse pin connecting the upper ends of the braces, a lever pivoted at its rear end upon the upper side of the beam and having a horizontal guide-frame receiving the pin of the braces, and a handle for raising and lowering said lever, substantially as specified.

2. The combination with a beam having opposite guides, of a plow-carrying standard pivoted at its upper end in rear of the guides to the beam, a pair of braces pivoted at their lower ends to the standard and mounted for movement in the guides, and a handle connected to the upper ends of the braces, adapted to raise and lower the same, and means for locking the braces in their elevated or depressed positions, substantially as specified.

3. The combination with a beam having opposite guides, of a standard pivoted at its upper end to the beam in rear of the guides, braces located in the guides and pivoted at their lower ends to the standard, a pin connecting the upper ends of the braces, a lever pivoted at its rear end to the upper side of the frame and having an elongated frame for receiving and guiding the pin, a handle loosely connected to the lever, and a locking device for engaging the upper or lower side of the beam, and devices for securing the standard in a raised or depressed position, substantially as specified.

4. The combination with a beam having the opposite guides, the plow-carrying standard pivoted to the under side of the beam, and the braces arranged in the guide and pivoted at their lower ends to the beam, of the lever

pivoted at its rear end upon the upper side of the beam and having a horizontal guide-frame at the free end thereof, a pin passing through the braces and through the guide-frame, a handle loosely connected to the lever, a plate extending from the handle to one side of one of the braces and having a bolt for engaging the upper or under side of the beam, and a spring secured to one of the braces and bearing on the bolt and normally pressing the same inward, substantially as specified.

5. The combination with a beam having a rear notched end, of a vertical hopper angular in cross-section and fitting the notched end, a metal strap embracing the hopper and bolted to the opposite side of the beam, furrow-forming and closing devices carried by the beam, and feed-devices arranged in the hopper, substantially as specified.

6. The combination with the beam, the hopper at the rear end thereof, the opposite han-

dles secured to the beam and projecting in rear thereof and having a transverse connecting rung provided with keepers, a guide-frame secured to the rear side of the hopper and terminating in hooks removably engaging the keepers, a lever pivoted between its ends to the rear side of the hopper and passing through the guide-plate, of a cut-off arranged upon the lower end of the hopper and connected loosely with the lower end of the lever, and a locking-frame through which the rear end of the cut-off passes, substantially as specified.

In testimony that we claim the foregoing as our own we have hereto affixed our signatures in the presence of two witnesses.

JAMES HARPER.
FRANCIS CLINGFAST.

Witnesses:

J. B. HUDSON,
W. O. TATUM.