

(19) **DANMARK**



Patent- og
Varemærkestyrelsen

(10) **DK/EP 3618936 T3**

(12) **Oversættelse af
europæisk patentskrift**

-
- (51) Int.Cl.: **A 63 B 71/12 (2006.01)** **A 41 D 13/015 (2006.01)** **A 41 D 13/05 (2006.01)**
A 61 F 5/055 (2006.01) **F 41 H 1/00 (2006.01)**
- (45) Oversættelsen bekendtgjort den: **2023-12-04**
- (80) Dato for Den Europæiske Patentmyndigheds bekendtgørelse om meddelelse af patentet: **2023-08-30**
- (86) Europæisk ansøgning nr.: **18794080.4**
- (86) Europæisk indleveringsdag: **2018-05-04**
- (87) Den europæiske ansøgnings publiceringsdag: **2020-03-11**
- (86) International ansøgning nr.: **CA2018000088**
- (87) Internationalt publikationsnr.: **WO2018201222**
- (30) Prioritet: **2017-05-05 US 201762502254 P** **2017-08-10 US 201762543854 P**
- (84) Designerede stater: **AL AT BE BG CH CY CZ DE DK EE ES FI FR GB GR HR HU IE IS IT LI LT LU LV MC MK MT NL NO PL PT RO RS SE SI SK SM TR**
- (73) Patenthaver: **Kapsul Tech Corp., 398 Union Blvd., Kitchener, ON N2M 2T4, Canada**
- (72) Opfinder: **CORRIGAN, Charles Ryan, 26 Aberdeen Road, Kitchener, Ontario N2M 2Y5, Canada**
- (74) Fuldmægtig i Danmark: **Murgitroyd & Company, Mannerheimvägen 12 B, 5:e våningen, FI-00100 Helsingfors, Finland**
- (54) Benævnelse: **Beskyttelsesartikler og fremgangsmåder dertil**
- (56) Fremdragne publikationer:
DE-U1-202006 013 732
US-A- 5 328 447
US-A1- 2010 122 404
US-A1- 2011 010 829
US-A1- 2014 224 849
US-A1- 2014 289 939
US-A1- 2015 257 461

DESCRIPTION

CROSS-REFERENCE

[0001] This application is related to U.S. Provisional Patent Application No. 62/502,254, filed May 5, 2017, and U.S. Provisional Patent Application No. 62/543,854, filed August 10, 2017.

BACKGROUND

[0002] In sports, military operations, and other vigorous physical activities, the human body may be subjected to significant stresses. For example, impacts to the head and/or body can cause angular/rotational acceleration (whiplash) of the head and neck, and angular/rotational acceleration and whiplash are associated with concussions. The neck/spine or other parts of the body such as the elbow(s), wrist(s), hip(s), knee(s), and/or ankle(s) may also be subjected to musculoskeletal stress, strain, or fatigue.

[0003] US 5 328 447 describes a spine protector for use with or without protective clothing and in particular, in bomb disposal suits or in sports related activities.

SUMMARY OF THE INVENTION

[0004] The invention provides an article for support and protection wearable by a subject according to claim 1. Preferred embodiments are provided in the dependent claims Any embodiments or aspects of the disclosure below which are not encompassed by the claims are provided for reference only.

[0005] Also disclosed, but not claimed, herein are methods of manufacturing and methods of using said articles. The articles may utilize a suitable material for absorbing, resisting, reducing, or counteracting a force. The material can be a non-Newtonian material that has force-reactive or rate-sensitive properties.

BRIEF DESCRIPTION OF THE DRAWINGS

[0006] A better understanding of the features and advantages of the present invention will be obtained by reference to the following detailed description that sets forth illustrative embodiments and the accompanying drawings of which: Figures 1-60 are not embodiments of the invention but useful for the understanding thereof.

FIG. 1 is a superior dorsal isometric view of a first exemplary spinal support device, in

accordance with some embodiments;

FIG. 2 is a superior ventral isometric view of the spinal support device of **FIG. 1**, in accordance with some embodiments.

FIG. 3 is an inferior dorsal isometric view of the spinal support device of **FIG. 1**, in accordance with some embodiments.

FIG. 4 is an inferior ventral isometric view of the spinal support device of **FIG. 1**, in accordance with some embodiments.

FIG. 5 is a front (dorsal) elevation view of the spinal support device of **FIG. 1**, in accordance with some embodiments.

FIG. 6 is a side elevation view of the spinal support device of **FIG. 1**, in accordance with some embodiments.

FIG. 7 is a rear (ventral) elevation view of the spinal support device of **FIG. 1**, in accordance with some embodiments.

FIG. 8 is a top plan view of the spinal support device of **FIG. 1**, in accordance with some embodiments.

FIG. 9 is a bottom plan view of the spinal support device of **FIG. 1**, in accordance with some embodiments.

FIG. 10 is a detail front (dorsal) elevation view of a portion of the spinal support device of **FIG. 1**, in accordance with some embodiments.

FIG. 11 is a cross-sectional view of a portion of the spinal support device of **FIG. 1**, taken along the line A-A in **FIG. 10**, in accordance with some embodiments.

FIG. 12 is a detail side elevation view of a portion of the spinal support device of **FIG. 1**, in accordance with some embodiments.

FIG. 13 is a detail rear (ventral) elevation view of a portion of the spinal support device of **FIG. 1**, in accordance with some embodiments.

FIG. 14 is a superior dorsal isometric view of a second exemplary spinal support device, in accordance with some embodiments.

FIG. 15 is a superior ventral isometric view of the spinal support device of **FIG. 14**, in accordance with some embodiments.

FIG. 16 is an inferior dorsal isometric view of the spinal support device of **FIG. 14**, in accordance with some embodiments.

FIG. 17 is an inferior ventral isometric view of the spinal support device of **FIG. 14**, in accordance with some embodiments.

FIG. 18 is a front (dorsal) elevation view of the spinal support device of **FIG. 14**, in accordance with some embodiments.

FIG. 19 is a side elevation view of the spinal support device of **FIG. 14**, in accordance with some embodiments.

FIG. 20 is a rear (ventral) elevation view of the spinal support device of **FIG. 14**, in accordance with some embodiments.

FIG. 21 is a top plan view of the spinal support device of **FIG. 14**, in accordance with some embodiments.

FIG. 22 is a bottom plan view of the spinal support device of **FIG. 14**, in accordance with some embodiments.

FIG. 23 is a detail front (dorsal) elevation view of a portion of the spinal support device of **FIG. 14**, in accordance with some embodiments.

FIG. 24 is a cross-sectional view of a portion of the spinal support device of **FIG. 14**, taken along the line B-B in **FIG. 23**, in accordance with some embodiments.

FIG. 25 is a detail side elevation view of a portion of the spinal support device of **FIG. 14**, in accordance with some embodiments.

FIG. 26 is a detail rear (ventral) elevation view of a portion of the spinal support device of **FIG. 14**, in accordance with some embodiments.

FIG. 27 is a cross-sectional view of part of a third exemplary spinal support device, taken along the line 27-27 in **FIG. 34** showing a first alignment with human vertebrae, in accordance with some embodiments.

FIG. 28 is a partial cut-away view of the part of the spinal support device shown in **FIG. 27**, showing the first alignment with human vertebrae, in accordance with some embodiments.

FIG. 29 is the same cross-sectional shown in **FIG. 27** but showing a second alignment with human vertebrae, in accordance with some embodiments.

FIG. 30 is an exploded top dorsal perspective view of the spinal support device of **FIG. 27**, in accordance with some embodiments.

FIG. 31 is a partially exploded top ventral perspective view of the spinal support device of **FIG. 27**, in accordance with some embodiments.

FIGS. 32A and **32B** are partial cross-sectional views taken along the line **32A/B-32A/B** in **FIG. 31**, in accordance with some embodiments.

FIG. 33 is a cross-sectional view of a cervical spine support portion of the spinal support device of **FIG. 27**, taken along the line 33-33 in **FIG. 34**, in accordance with some embodiments.

FIG. 34 is a dorsal view of the cervical spine support portion and a trapezius grapnel of the spinal support device of **FIG. 27**, in accordance with some embodiments.

FIG. 35 is a plan view of a resilient C-shaped retainer of the spinal support device of **FIG. 27**, in accordance with some embodiments.

FIG. 36 is a front perspective view of the spinal support device of **FIG. 27** harnessed to a human, in accordance with some embodiments.

FIG. 37 is a rear perspective view of the spinal support device of **FIG. 27** harnessed to a human, in accordance with some embodiments.

FIG. 38 is a rear elevation view of a portion of a fourth exemplary spinal support device, in accordance with some embodiments.

FIG. 39 is a cross-sectional view taken along the line A-A' in **FIG. 38**, in accordance with some embodiments.

FIG. 39A shows a first alternate compression shirt fastening for the spinal support device of **FIG. 38**, in accordance with some embodiments.

FIG. 39B shows a second alternate compression shirt fastening for the spinal support device of **FIG. 38**, in accordance with some embodiments.

FIG. 40 is a front perspective view of the spinal support device of **FIG. 38** harnessed to a human, in accordance with some embodiments.

FIG. 41 is a rear perspective view of the spinal support device of **FIG. 38** harnessed to a human, in accordance with some embodiments.

FIG. 42 is a side elevation view of a portion of the spinal support device of **FIG. 38**, in accordance with some embodiments.

FIG. 43 is a cross-sectional view taken along the line B-B' in **FIG. 42**, in accordance with some embodiments.

FIG. 44 is a front elevation view of a portion of the spinal support device of **FIG. 38**, in accordance with some embodiments.

FIG. 45 is a cross-sectional view taken along the line C-C' in **FIG. 44**, in accordance with some embodiments.

FIG. 46A is a cross-sectional view taken along the line D-D' in **FIG. 44** showing a first construction for a ventral liner, in accordance with some embodiments.

FIG. 46B is a cross-sectional view taken along the line D-D' in **FIG. 44** showing a second construction for a ventral liner, in accordance with some embodiments.

FIG. 47 is a front elevation view of a portion of the spinal support device of **FIG. 38** showing

fastening thereof, in accordance with some embodiments.

FIG. 48A is an exploded view showing construction of an exemplary adjustment strap of the spinal support device of **FIG. 38**, in accordance with some embodiments.

FIG. 48B is an exploded view showing construction of an exemplary harness of the spinal support device of **FIG. 38**, in accordance with some embodiments.

FIG. 49, **FIG. 50A**, and **FIG. 50B** show two exemplary methods for forming frame elements and a collar member of the spinal support device of **FIG. 38** and coupling them together.

FIG. 51, **FIG. 52A**, and **FIG. 52B** show another two exemplary methods for forming frame elements and a collar member of the spinal support device of **FIG. 38** and coupling them together.

FIG. 53, **FIG. 54A**, and **FIG. 54B** show another two exemplary methods for forming frame elements and a collar member of the spinal support device of **FIG. 38** and coupling them together.

FIG. 55, **FIG. 56**, and **FIG. 57** show an alternate structure for a compression shirt, integrated harness and adjustment straps of the spinal support device of **FIG. 38**, in accordance with some embodiments.

FIG. 58 shows a front perspective view of an alternate structure for a compression shirt, integrated harness, and adjustment straps of the spinal support device of **FIG. 38**, in accordance with some embodiments.

FIG. 59 shows a rear perspective view of an alternate structure for a compression shirt, integrated harness, and adjustment straps of the spinal support device of **FIG. 38**, in accordance with some embodiments.

FIG. 60 shows front and rear views of an alternate structure for a compression shirt, integrated harness, and adjustment straps of the spinal support device of **FIG. 38**, optionally integrated with compression pants or leggings in accordance with some embodiments.

FIG. 61A shows a front view of an exemplary article, in accordance with some embodiments.

FIG. 61B shows a back view of the exemplary article of **FIG. 61A**, in accordance with some embodiments.

FIG. 61C shows a side view of the exemplary article of **FIG. 61A**, in accordance with some embodiments.

FIG. 61D shows a detailed front view of the exemplary article of **FIG. 61A**, in accordance with some embodiments.

FIG. 61E shows a detailed back view of the exemplary article of **FIG. 61A**, in accordance with some embodiments.

FIG. 61F shows a detailed side view of the exemplary article of **FIG. 61A**, in accordance with some embodiments.

FIG. 62A shows a front view of the adjustable tension areas of the exemplary article of **FIG. 61A**, in accordance with some embodiments.

FIG. 62B shows a back view of the adjustable tension areas of the exemplary article of **FIG. 61A**, in accordance with some embodiments.

FIG. 62C shows a side view of the adjustable tension areas of the exemplary article of **FIG. 61A**, in accordance with some embodiments.

FIG. 63A shows a front view of the adjustable tension areas of the exemplary article of **FIG. 61A**, in accordance with some embodiments.

FIG. 63B shows a back view of the adjustable tension areas of the exemplary article of **FIG. 61A**, in accordance with some embodiments.

FIG. 63C shows a side view of the adjustable tension areas of the exemplary article of **FIG. 61A**, in accordance with some embodiments.

FIG. 64A shows a front view of an exemplary long-sleeved second article, in accordance with some embodiments.

FIG. 64B shows a front view of an exemplary no-sleeve second article, in accordance with some embodiments.

FIG. 64C shows a detailed front view of the exemplary second article of **FIG. 64A**, in accordance with some embodiments.

FIG. 64D shows a back view of the exemplary second article of **FIG. 64A**, in accordance with some embodiments.

FIG. 64E shows a cross-sectioned side view of the exemplary second article of **FIG. 64A**, with a detailed view of a neck support element in accordance with some embodiments.

DETAILED DESCRIPTION OF THE INVENTION

[0007] Disclosed herein, in certain aspects, are wearable articles that integrate a rate-sensitive material to provide protection without sacrificing freedom of motion. The spinal support devices or support elements constructed according to the present disclosure reduce muscle fatigue by supporting the head and neck in lateral motion and flexion, and by absorbing rotational energy during lateral motion/flexion of the head and neck during an impact, a blow, or any acceleration greater than the one the subject can generate by himself. The support elements are configured to provide increasing resistance and energy absorption in response to the degree

of the applied force.

[0008] In some embodiments, the wearable article comprises a force-directing frame comprising a plurality of frame elements, and is shaped and dimensioned to be anatomically complementary to a body region of a subject. The subjects with which the wearable articles are used are preferably vertebrates, more preferably mammals and most preferably human. Thus, wearable articles according to the principles elucidated in the present disclosure may include not only humans but, for example and without limitation, ungulates such as sheep, goats, horses, donkeys and mules, reptiles, amphibians, companion animals such as dogs and cats, and other pets such as birds and rodents. Wearable articles according to the present disclosure may be incorporated into protective equipment worn not only by humans but also by military and police animals such as dogs and horses. Wearable articles as disclosed herein may be used in both human and veterinary medical applications, preferably without any surgical implantation.

[0009] In some embodiments, the rate-sensitive material is coupled to the frame, and at least one fastener is coupled (directly or indirectly) to the frame and adapted to secure the wearable article on the subject. A wide variety of fasteners can be used, including but not limited to one or more of harnesses, straps, integration into articles, and so on. In the case of harnesses or straps, these may be removable or permanently affixed. Preferably, the wearable article is secured externally, that is, outside of the body of the subject, and non-invasively, that is, without surgery or implantation of any elements into the body of the subject, although embodiments in which all or part of the support is implanted are also contemplated. As noted above, the wearable article can be anatomically complementary to the body region with which it will be used.

[0010] In some embodiments, the wearable article will include an engagement surface, which may be a continuous surface or an interrupted surface, for engaging the body region. The engagement surface may include channels and/or protrusions to facilitate airflow. The shape of the engagement surface is complementary to the surface contours of the anatomical structure of the body region to which the wearable article is secured. For example, where the body region is the neck and trapezius muscles, the wearable article may have an elongate channel which receives the neck and then broadens at the base to accommodate the trapezius muscles. Similarly, a wearable article for an elbow joint may be shaped to engage the distal brachium, antecubitis, olecranon and proximal antebrachium, or parts thereof, and include an engagement surface adapted for such purpose. These are merely examples of body regions with which wearable articles described herein may be used, and are not intended to be limiting. For example, and without limitation, wearable articles according to the present disclosure may be adapted to provide support to all or part of any of the head and neck in combination, the neck, the torso, the spine, one or both shoulders, one or both elbows, one or both wrists, one or both hands, one or both hips, one or both knees, one or both ankles, and/or one or both feet.

[0011] When secured by the fastener(s), in certain embodiments, the wearable article will be in registration with the body region in close topographical engagement therewith. For example,

one or more layers of sufficiently thin, close-fitting clothing, including protective clothing, may be interposed between the body region and the wearable article without preventing close topographical engagement between the body region and the wearable article. Moreover, the term "close topographical engagement" encompasses gaps in engagement between the wearable article and the body region (e.g. an interrupted engagement surface), for example for ventilation or for mobility, as long as there is sufficient engagement to permit effective transmission of forces from the body region to the wearable article.

[0012] In some embodiments, the frame elements of the force-directing frame form at least one deformable region within the frame; that is, a region of the frame which can undergo deformation in response to forces applied to the frame. This deformation can be achieved, for example and without limitation, by resilience/flexibility of all or part of the relevant frame members, including areas of reduced thickness serving as living hinges, by conventional hinging of one frame element to another, by one frame element being slidably engaged with another frame elements, by combinations of the foregoing, or by other suitable techniques. In some embodiments, the force-directing frame comprises a monolithic unit, or alternatively, a plurality of individual frame elements, which are connected to one another, separate and spaced from one another, or a combination (e.g. some frame elements may be connected to other frame elements and some frame elements may not be connected to other frame elements).

[0013] In some embodiments, the frame elements are configured to, when the wearable article is secured on the body region, divert at least a portion of internal contortion forces within the body region through the frame elements to the deformable region(s); the force transfer is achieved by way of the close topographical engagement between the wearable article and the body region. The term "internal contortion forces" refers to the movements of anatomical structures relative to one another during movement of the body, for example the relative movements of bones, cartilage, muscle, and other soft tissue during flexion, extension, or rotation of a joint. The internal contortion forces may be the result of externally applied forces, internal forces generated by the musculature of the body region, or a combination of both internal and external forces. For example, an athlete or soldier may be subjected to external forces by a projectile impact which causes movement of his or her body, or subjected to internal forces when spinning suddenly in response to a noise, or to both internal and external forces when attempting to maintain balance during a contact sport (e.g. American football, rugby or martial arts) or in actual hand-to-hand, hand-to-weapon or weapon-to-weapon combat.

[0014] In some embodiments, the rate-sensitive material is disposed at least within the deformable region(s), and the rate-sensitive material damps the diverted internal contortion forces by deformation of the rate-sensitive material within the deformable region(s). In effect, the deformable regions containing the rate-sensitive material function as "crumple zones" which absorb some of the forces (internal, external or both) that would otherwise be applied to the body region. The particular rate-sensitive material used, and its density and thickness, will depend on how the wearable article will be used (e.g. the nature of the activity) and the body

region with which the wearable article may be used, and may also depend on the characteristics of the individual subject (e.g. height, weight, strength and other conditioning factors, etc.). Moreover, different types, thicknesses and densities of rate-sensitive materials may be used in different deformable regions or even within a single deformable region (e.g. laminated in layers or arranged in a deformable sequence), and the properties of the rate-sensitive material(s) may be further tuned by applying suitable coatings or laminates to surface(s) of the rate-sensitive materials, for example to modify the surface tension of the rate-sensitive materials. In some embodiments, the wearable article comprises a monolithic quantity of rate-sensitive material, and the frame elements may be overlaid onto or set into the rate-sensitive material to form the force-directing frame and define the deformable regions. In other embodiments, discrete, separate individual portions of rate-sensitive materials may be disposed in the deformable regions.

[0015] In some embodiments, the precise shape, location and configuration of the deformable region(s) will depend on the particular application in which the wearable article is to be used and/or the body region to be supported. In one preferred embodiment, the wearable article is anatomically non-restrictive. One preferred approach is to recreate, mimic, emulate or conform to anatomical structural arrays or groupings, such as for example all or part of any of the head and neck in combination, the neck, the torso, the spine, one or both shoulders, one or both elbows, one or both wrists, one or both hands, one or both hips, one or both knees, one or both ankles, and/or one or both feet. By recreating, mimicking, emulating or conforming to anatomical structural arrays the wearable article can, by its close topographical engagement with the body region, divert at least some of the internal contortion forces away from vulnerable soft tissues and strategically direct the diverted forces to the deformable region(s) where those forces can be attenuated, absorbed or damped by the rate-sensitive materials therein. In some such embodiments the frame elements correspond to hard tissue such as bone and/or cartilage and the deformable regions containing rate-sensitive materials may correspond to soft tissue such as muscle and connective tissue. In such embodiments, the frame elements is positioned in registration with hard tissues that would transmit the forces and the deformable regions containing the rate-sensitive materials may be positioned in registration with those soft tissues in the body region that would undergo deformation when subjected to internal contortion forces and be susceptible to injury as a result. In some instances, registration between the frame elements and the hard tissues and/or between the deformable regions and the vulnerable soft tissues is not required so long as the wearable article is configured to divert at least some of the internal contortion forces away from vulnerable soft tissues and strategically direct the diverted forces to the deformable region(s). In either case, the configuration of the wearable article is preferably such that it permits the wearer to move the relevant body region(s) through substantially normal ranges of motion (e.g. flexion, extension, rotation). In some embodiments, the primary protection provided by the wearable article results not from substantial restrictions on range of motion, but from diversion of internal contortion forces to the deformable regions where the properties of the rate-sensitive materials therein can be exploited.

[0016] As noted above, a rate-sensitive material can be a material whose resistance to applied

force increases with increasing force. In some embodiments, wearable articles according to the present disclosure leverage the compressible/expandable/viscoelastic properties of rate-sensitive materials. By selection of appropriate rate-sensitive materials for the activities with which the wearable article will be used, a wearable article can be constructed in which the rate-sensitive materials will offer very little resistance to the diverted internal contortion forces when those forces are applied at the rates expected for that activity. As such, the wearable article will provide little resistance to the subject's ordinary motion during the activity. At moments of high energy (e.g. sudden hyperextension, acceleration, deceleration such as arising from an impact), the internal contortion forces will be applied at a much higher rate. When a portion of those higher-rate internal contortion forces are diverted to the deformable regions, they will meet much greater resistance from the rate-sensitive material therein. The effect of this greater resistance is a damping or absorption of the diverted internal contortion forces, which may result in the stabilization of movements or articulations known to cause injury. For example, without limitation and without promising any particular utility, it is contemplated that suitably designed wearable articles according to the present disclosure may assist in preventing or reducing whiplash, reducing fatigue, reducing the effect of applied G-forces (e.g. for aircrews), providing passive stabilization, providing load offset, providing lateral resistance, providing anterior and posterior resistance, improving and stabilizing posture, injury stabilization and immobilization, and anti-inversion sprain prevention.

[0017] While some preferred embodiments are anatomically non-restrictive, other embodiments may be anatomically restrictive, that is, they may impose substantial restrictions on the wearer's ordinary range of motion for the affected body region. Anatomically restrictive embodiments may be advantageous, for example, in injury stabilization and post-surgical applications, or in preventing neck fatigue (e.g. in pilots).

[0018] Notably, performance of the wearable articles disclosed herein is not dependent solely on the properties of the rate-sensitive materials, but on the interaction between the rate-sensitive materials and the materials of the force-directing frame; although, in some cases wearable articles are constructed according to the principles described herein using conventionally resilient materials in place of rate-sensitive materials. Moreover, the force-directing frame may take a wide range of forms so long as it performs the function of directing the energy dissipation by distributing forces to specific areas of the rate-sensitive material (or resilient material). For example, a force-directing frame may comprise or consist of one or more regions of thin film (which may be of monolithic or composite structure) having suitable force-directing properties and that is laminated, adhered, or otherwise secured to the rate-sensitive material (or resilient material). The term "energy-absorbing material" is used herein to encompass both rate-sensitive materials and conventional resilient materials.

[0019] As noted above, in certain embodiments, the deformable regions containing the rate-sensitive material function as "crumple zones" which absorb some of the forces (internal, external or both) that would otherwise be applied to the body region. In some embodiments, the frame elements control the surface of the rate-sensitive material to transform what would otherwise be a flexing motion into compression, where the rate-sensitive material is most

effective in absorbing/damping force. More particularly, the frame elements may be made from a material that is harder, e.g. more rigid, than the rate-sensitive material, and the surfaces of the frame elements can compress the rate-sensitive material so that the shape and configuration of the frame elements can direct where, and to what degree, the rate-sensitive material absorbs energy. For example, the frame elements may be rigid or semi-rigid, so long as they are sufficiently more rigid than the rate-sensitive material to effectively control the compression of the particular rate-sensitive materials given the forces expected to be applied. The properties (e.g. rigidity) of the frame elements and the properties (e.g. density) of the rate-sensitive material will depend on the activity with which the wearable article will be used. More rigid frame elements and denser rate-sensitive material may be used for high intensity sports/activities (e.g. hockey, football, military, motor sports) and less rigid frame elements and lower density rate-sensitive material may be used for low intensity applications (e.g. injury recovery, proprioception, mitigation of neck/joint fatigue or strain, etc.). In certain applications, the energy-absorbing material in one or more of the deformable regions may function as a symphyseal resistive joint (as described below).

[0020] In some embodiments, one or more of the frame elements include a projection, layer, or outer surface which extends over a deformation region to provide additional protection (e.g. impact protection). For example, a rigid foam or rubber material may be provided around the knees, elbows or other joints. Wearable articles as described herein may include or be integrated with one or more additional layers to provide additional functionality. For example, additional layers may provide padding for impact protection, cut protection, projection against projectiles (e.g. a layer of para-aramid synthetic fiber such as that marketed under the trademark Kevlar®), insulation, or comfort. Optionally, the additional layers may be interchangeable so that a single core wearable article can be adapted for use in different activities (e.g. a single custom-fitted wearable article for the cervical spine may be removably inter-engageable with both American football padding/armor and ice hockey padding/armor. In some embodiments, additional layers may incorporate gel-filled or fluid-filled chambers to provide impact protection and/or cushioning. An innermost layer may also be provided to improve the close topographical engagement of the wearable article with the body region. An exemplar combination of layers utilized in the wearable article such as within a support element includes an outer layer of a rigid foam, rubber, or plastic material, an internal or middle layer of a rate-sensitive material (e.g. a non-Newtonian material suspended in a foam matrix) whose viscosity increases in response to increasing force, and an inner layer of a soft foam or padding to help cushion the surface of the wearer's anatomy in contact with the support element and/or wearable article.

[0021] Optionally, electronic sensors (e.g. optical sensors, force sensors, or others) may be incorporated into wearable articles according to the present disclosure. For example, suitable accelerometers may be used as force sensors. Where electronic sensors are used, these may be coupled (e.g. by wire) to an onboard computer or onboard data storage, or to a transmitter (e.g. a radio, Wi-Fi, or Bluetooth transmitter) which may communicate wirelessly with a computing device (e.g. a smartphone or tablet).

[0022] In various aspects, the wearable articles described herein enable a method for limiting injurious motion. This method comprises diverting, through a wearable article secured on a body region of a subject, at least a portion of internal contortion forces within the body region to rate-sensitive material disposed within at least one deformable region within a frame of the wearable article, and damping or absorbing the diverted internal contortion forces by deformation of the rate-sensitive material within the at least one deformable region.

[0023] Certain exemplary wearable articles in the form of spinal support devices (which can be integrated into the wearable articles described herein as support elements) will now be described by way of example, it being understood that the teachings of the present disclosure are not limited to spinal support devices, but may be applied to articles for a wide range of anatomical structures.

[0024] Reference is now made to **FIGS. 1 to 13**, which show a first exemplary spinal support device, indicated generally by reference **100**. The spinal support device shown in **FIGS. 1 to 13** is one exemplary implementation of a wearable article according to the present disclosure, and serves as an article for an anatomical structure, in this case the neck/back/spine.

[0025] The spinal support device **100** comprises a cervical spine support portion **102**, an upper spinal support portion **104**, and a lower spinal support portion **106**. The cervical spine support portion **102** is coupled to the superior end **108** of the upper spinal support portion **104** and the lower spinal support portion **106** extends from an inferior end **110** of the upper spinal support portion **104**. The upper spinal support portion **104** and the lower spinal support portion **106** may be monolithically formed as a single element, or may be formed as two parts (each of which may consist of sub-parts) joined to one another.

[0026] When worn by a human subject (not shown in **FIGS. 1 to 13**), the upper spinal support portion **104** and lower spinal support portion **106** together extend from the C7 vertebra to at least the L1 vertebra on a human spine and, as can be seen, the spinal support device **100** is contoured to fit the curvature of a human back. Thus, as best seen in **FIG. 6**, the upper spinal support portion **104** and the lower spinal support portion **106** are adapted to conform to human spinal curvature and, in use, would be secured in position over the wearer's spine as described further below. The interior contours of the spinal support device **100** form an engagement surface that conforms to the external surface contours of the back and neck.

[0027] The superior end **108** of the upper spinal support portion **104** comprises a biomechanically rigid trapezius grapnel **112** adapted to extend over and engage human trapezius muscles from a dorsal position toward a ventral position on a human subject. The term "biomechanically rigid", as used herein, means sufficiently rigid to transmit substantially all applied force rather than absorbing the force by deformation. In this sense, the term "biomechanically rigid" means rigid in the same sense that the bones of the skeleton are rigid and thus the term "biomechanically rigid" does not preclude some flexibility. The entirety of the upper spinal support portion **104** may be biomechanically rigid, or only the trapezius grapnel **112** may be biomechanically rigid. Optionally, the upper spinal support portion **104** may be

constructed so that the trapezius grapnel 112 is biomechanically rigid and the rigidity of the upper spinal support portion 104 decreases (e.g. the flexibility increases) toward the inferior end 110 thereof. In preferred embodiments, the lower spinal support portion 106 is substantially more flexible than the upper spinal support portion 104.

[0028] In the illustrated embodiment, the superior end 108 of the upper spinal support portion 104 is generally trident-shaped and the trapezius grapnel 112 comprises outwardly extending opposed trapezius support arms 114 and a spinal support arm 116 disposed between the trapezius support arms 114. Slots 118 are interposed between the spinal support arm 116 and the trapezius support arms 114. The trapezius support arms 114 are adapted to engage human trapezius muscles and thereby stabilize the spinal support device 100 while enabling force to be transferred from the cervical spine support portion 102 to the trapezius muscles or, more broadly, the upper torso. The mechanism used to secure the upper spinal support portion 104 and the lower spinal support portion 106 over the wearer's spine will also maintain the trapezius grapnel 112 in engagement with the wearer's trapezius muscles. The trident shape is merely one exemplary shape for the trapezius grapnel 112 and other suitable shapes may also be used.

[0029] As best seen in FIGS. 10 to 13, the cervical spine support portion 102 comprises a generally C-shaped biomechanically rigid C6 vertebra support 120, a generally C-shaped biomechanically rigid C4 vertebra support 122, and a generally C-shaped biomechanically rigid atlas support 124. When the spinal support device 100 is worn by a human subject, the C6 vertebra support is aligned with and positioned to cradle a human C6 vertebra from a dorsal side thereof, the C4 vertebra support is aligned with and positioned to cradle a human C4 vertebra from a dorsal side thereof, and the atlas support 124 is aligned with and positioned to cradle human C1 and C2 vertebrae from a dorsal side thereof.

[0030] The upper spinal support portion 104 and lower spinal support portion 106 together form a force-directing frame of a wearable article, and the trapezius support arms 114, spinal support arm 116, C6 vertebra support 120, C4 vertebra support 122, and atlas support 124 are frame elements thereof. As can be seen, the force-directing frame formed by the upper spinal support portion 104 and lower spinal support portion 106 is shaped and dimensioned to be anatomically complementary to a body region, in this case the back and neck, of a subject, in this case a human.

[0031] The C6 vertebra support 120, C4 vertebra support 122, and atlas support 124 are spaced from one another and joined together by respective symphyseal resistive joints formed by symphyseal resistive dampers extending there-between. The term "symphyseal resistive damper" means an element or set of elements which, when interposed between two parts, can function as a symphyseal gliding joint between those two parts and permits limited relative angular (flexion/extension) and rotational movement of one of the parts relative to another while resisting the force of such movement so as to apply a braking/decelerating effect to such movement, and "symphyseal resistive joint" refers to a joint comprising a "symphyseal resistive damper". A C6-C4 symphyseal resistive damper extends between the C6 vertebra support 120

and the C4 vertebra support **122** to form a C6-C4 symphyseal resistive joint **126** therebetween, and a C4-atlas symphyseal resistive damper extends between the C4 vertebra support **122** and the atlas support **124** to form a C4-atlas symphyseal resistive joint **128** therebetween. The cervical spine portion **102** is joined to the superior end **108** of the upper spinal support portion **104** by an upper spine-cervical spine symphyseal resistive damper extending between the superior end **108** of the upper spinal support portion and the C6 vertebra support **120** which forms an upper spine-cervical spine symphyseal resistive joint **130**. Thus, a plurality of dampers is engaged with the force-directing frame formed by the upper spinal support portion **104** and lower spinal support portion **106** to absorb forces therefrom. As can be seen in the **FIGS.**, the force-directing frame (upper spinal support portion **104** and lower spinal support portion **106**) and the dampers (symphyseal resistive joints **126**, **128**, **130**) are shaped and positioned relative to one another to be anatomically complementary to an anatomical structure of a subject, in this case the back and upper spine of a human being. This anatomical structure comprises hard tissue (vertebrae) and soft tissue (e.g. muscle, intervertebral discs).

[0032] In the exemplary embodiment shown in **FIGS. 1 to 13**, the C6-C4 symphyseal resistive joint **126**, the C4-atlas symphyseal resistive joint **128** and the upper spine-cervical spine symphyseal resistive joint **130** are each discrete joints formed from separate pieces of energy-absorbing material. Thus, the force-directing frame comprises a plurality of discrete force-directing elements (trapezius grapnel **112**, C6 vertebra support **120**, C4 vertebra support **122** and atlas support **124**) spaced from one another by the dampers (symphyseal resistive joints **130**, **126**, **128**) extending between adjacent force-directing elements. In the illustrated embodiment, the C6-C4 symphyseal resistive joint **126** is a generally C-shaped element that extends between the superior end of the C6 vertebra support **120** and the inferior end of the C4 vertebra support **122**, and the C4-atlas symphyseal resistive joint **128** is a generally C-shaped element that extends between the superior end of the C4 vertebra support **122** and the inferior end of the atlas support **124**. The upper spine-cervical spine symphyseal resistive joint **130** conforms to the shape of the trapezius grapnel **112** and extends both inferiorly and superiorly thereof. More particularly, the upper spine-cervical spine symphyseal resistive joint **130** is on the ventral side of the upper spinal support portion **104** and extends inferiorly beyond the slots **118** and superiorly beyond the trapezius support arms **114** and a spinal support arm **116**. Beyond the superior end **108** of the upper spinal support portion **104**, the upper spine-cervical spine symphyseal resistive joint **130** converges to form a penannular collar **132** extending to the inferior end of the C6 vertebra support **120**. In the illustrated embodiment, the material that forms the upper spine-cervical spine symphyseal resistive joint **130** also extends inferiorly along the ventral surface of the spinal support device **100** to the inferior end **140** of the lower spinal support portion **106**. In other embodiments the material that forms the upper spine-cervical spine symphyseal resistive joint may not extend as far inferiorly; for example the material may extend only to the inferior end of the upper spinal support portion.

[0033] The energy-absorbing material used to form the C6-C4 symphyseal resistive joint **126**, the C4-atlas symphyseal resistive joint **128** and the upper spine-cervical spine symphyseal resistive joint **130** may be, for example, an elastomeric material or a suitable force-reactive polymer such as those described herein. Thus, in one embodiment of the exemplary spinal

support device **100** shown in **FIGS. 1 to 13**, a quantity of rate-sensitive material is coupled to the force-directing frame (upper spinal support portion **104** and lower spinal support portion **106**) to form the symphyseal resistive joints **126, 128, 130**. In this particular embodiment, these symphyseal resistive joints **126, 128, 130** are the deformable regions in which the rate-sensitive material is disposed.

[0034] The relative positions of the trapezius grapnel **112**, C6 vertebra support **120**, C4 vertebra support **122** and atlas support **124** and the symphyseal resistive joints **126, 128, 130** allow the cervical spine support portion **102** and the superior end **108** of the upper spinal support portion **104** to mimic the natural articulation of a human spine. At the same time, the structure provides resistance to applied force causing flexion/extension/rotation of the spine (e.g. from a ball or another player impacting the head and/or body), thereby reducing angular/rotational acceleration (whiplash) of the head and neck from impact to the head or body). Specifically, the energy-absorbing material forming the symphyseal resistive joints **126, 128, 130** provides progressively increasing resistance to deformation. The deformation may be compression, tension, or a combination (depending on the nature of the movement, some parts of a particular symphyseal resistive joint may be in compression while other parts are in tension). Where the symphyseal resistive joints are formed from an elastomeric material, the resistance to deformation will increase as displacement increases, and where the symphyseal resistive joints are formed from a force-reactive polymer, the resistance to deformation will increase as the applied force increases. Since relative movement of the trapezius grapnel **112**, C6 vertebra support **120**, C4 vertebra support **122** and atlas support **124** results in deformation of the symphyseal resistive joints **126, 128, 130**, the symphyseal resistive joints **126, 128, 130** provide a progressively increasing resistance toward the limits of the range of motion, which in turn provides a mechanical resistance to (e.g. braking/deceleration of) of whiplash-related and concussion-related movement. Thus, the frame elements (trapezius support arms **114**, spinal support arm **116**, C6 vertebra support **120**, C4 vertebra support **122** and atlas support **124**) are configured to divert at least a portion of internal contortion forces within the spine through the frame elements to the deformable regions (symphyseal resistive joints **126, 128, 130**) whereby the energy-absorbing material damps the diverted internal contortion forces by deformation of the energy-absorbing material within the deformable regions.

[0035] In order to couple movement of a subject's head to the spinal support device **100**, the spinal support device **100** is provided with at least one helmet integration element that is pivotally mounted to the atlas support **124**. In the exemplary embodiment shown in **FIGS. 1 to 13**, the spinal support device **100** is provided with a single generally C-shaped helmet integration element **134**. The atlas support **124** is pivotally nested within the helmet integration element **134** so that the helmet integration element **134** can pivot inferiorly and superiorly relative to the atlas support **124** within a limited range of pivotal motion. In the illustrated embodiment, the helmet integration element **134** is coupled to the atlas support **124** by opposed pivot pins **136**; suitable bushings and/or bearings (not shown) may be associated with the pivot pins **136**.

[0036] In use, a helmet (not shown) is coupled to the helmet integration element **134** so that

movement of the helmet during flexion and extension of the head will cause a corresponding movement of the helmet integration element **134**; preferably, the helmet can be releasably coupled to the helmet integration element **134**. For example, one or more tethers (not shown) may extend from the helmet integration element **134** for securing the helmet integration element **134** to a helmet (e.g. via snap fitting or other fastener) and the back of the helmet can be shaped to engage the helmet integration element **134**. In such an embodiment, movement of the helmet during flexion of the head will move the helmet integration element **134** via tension applied through the tethers, and movement of the helmet during extension of the head will move the helmet integration element **134** by way of the back of the helmet pushing on the helmet integration element **134**. In other embodiments, the helmet integration element **134** may be rigidly coupled to the helmet so that the helmet and the helmet integration element **134** move in unison.

[0037] When flexion and extension of the head are within the limited range of pivotal motion of the helmet integration element **134** relative to the atlas support **124**, the helmet integration element **134** can pivot freely relative to the atlas support **124**. Thus, the limited range of pivotal motion will be selected to correspond to an ordinary or "safe" range of flexion and extension to preserve freedom of movement. When flexion or extension of the head moves beyond the ordinary or "safe" range, the pivotal movement of the helmet integration element **134** relative to the atlas support **124** will exceed the limited range of pivotal motion. This will cause the helmet integration element **134** to engage the atlas support **124** so that further flexion/extension of the head will move the helmet integration element **134** and the atlas support in unison so that further movement will be resisted by C4-atlas symphyseal resistive joint **128** (and possibly the other symphyseal resistive joints **126**, **130**).

[0038] While helmets used in conjunction with the spinal support devices described herein will typically be specially adapted for coupling to the helmet integration element thereof, it is contemplated that different types of helmets may be provided for different activities, with each such helmet being similarly adapted for coupling to a helmet integration element. Thus, there may be different helmets for, for example, football, hockey, skateboarding, alpine sports, or other activities, with each such helmet being adapted for coupling to the same type of helmet integration element. In such an embodiment, a single spinal support device may be used for multiple activities by decoupling one helmet from the helmet integration element and then coupling a different helmet to the helmet integration element.

[0039] The spinal support device **100** may be secured on the dorsal side of a subject's torso in a variety of ways. For example, in one embodiment, a harness (not shown in **FIGS. 1** to **13**) may be used. The harness may comprise opposed fastening straps (not shown in **FIGS. 1** to **13**) that extend between the superior end **108** of the upper spinal support portion **102** (in particular the spinal support arm **116**) and the projections **138** at the Y-shaped inferior end **140** of the lower spinal support portion **106** for strapping the spinal support device **100** onto a subject's back. Thus, the fastening straps are adapted for fastening the upper spinal support portion and the lower spinal support portion onto a human back in registration with a spine thereof. In another embodiment, the upper spinal support portion **104** and the lower spinal

support portion **106** may be integrated into the dorsal side of a torso article such as a vest, compression shirt, or the like. Thus, the harness adapted to secure the wearable article (spinal support device **100**) externally and non-invasively on a human being in registration with the body region, in this case the back and neck, with the engagement surface in close topographical engagement with the surface contours of the back and neck, so that forces are transferred from the hard tissue (vertebrae) to the force-directing frame (upper spinal support portion **102** and lower spinal support portion **106**). With the spinal support device **100** so secured, at least a portion of the forces applied to the hard tissue (vertebrae) are diverted away from the soft tissue (e.g. muscle, intervertebral discs) to the dampers (symphyseal resistive joints **126**, **128**, **130**) by transfer of the forces from the hard tissue through the force-directing frame to the dampers whereby the dampers absorb the transferred portion of the forces and thereby limit internal forces applied to the soft tissue by the hard tissue.

[0040] Reference is now made to **FIGS. 14 to 26**, which show a second exemplary spinal support device, indicated generally by reference **200**. The second exemplary spinal support device **200** shown in **FIGS. 14 to 26** is similar to the first exemplary spinal support device **100** shown in **FIGS. 1 to 13**, with like features denoted by like reference numerals, except with the prefix "2" instead of "1". Thus, the cervical spine support portion of the second exemplary spinal support device **200** is denoted by reference **202**, the upper spinal support portion of the second exemplary spinal support device **200** is denoted by reference **204**, and so on. The second exemplary spinal support device **200** differs from the first exemplary spinal support device **100** primarily in that instead of being discrete joints formed from separate pieces of energy-absorbing material, in the second exemplary spinal support device **200** the symphyseal resistive dampers that form the C6-C4 symphyseal resistive joint **226**, the C4-atlas symphyseal resistive joint **228** and the upper spine-cervical symphyseal resistive joint **230** are formed from at least one monolithic layer of energy-absorbing material extending from the trapezius grapnel **212** along the cervical spine support portion **202**.

[0041] In the illustrated embodiment, one or more layers **242** of energy-absorbing material are disposed on the ventral side of the upper spinal support portion **204**, and extend from just above the inferior end **240** of the lower spinal support portion **206** superiorly to the upper spinal support portion **204** and along and past the trapezius grapnel **212** and then along the ventral side of the cervical spine support portion **202** to the atlas support **224**. The energy-absorbing material need not extend as far inferiorly as is shown in the illustrated embodiment but merely needs to extend far enough inferiorly to perform the symphyseal resistive joint functions. At the junction between the superior end **208** of the upper spinal support portion **204** and the C6 vertebra support **220**, the layer(s) **242** of energy-absorbing material converge to form a penannular collar **232** forming part of the upper spine-cervical spine symphyseal resistive joint **230**, and continue along the ventral side of the cervical spine support portion **202**. The C6-C4 symphyseal resistive joint **226** is formed by a portion of the layer(s) **242** of energy-absorbing material that projects dorsally between the C6 vertebra support **220** and the C4 vertebra support **222**, and the C4-atlas symphyseal resistive joint **228** is formed by a portion of the layer(s) **242** of energy-absorbing material that projects dorsally between the C4 vertebra support **122** and the atlas support **124**. The energy-absorbing material may be, for

example, an elastomeric material or a force-reactive polymer. Where multiple layers **242** are provided, the layers may be of identical, similar, or dissimilar energy-absorbing materials.

[0042] Reference is now made to **FIGS. 27 to 37**, which show a third exemplary spinal support device, indicated generally by reference **300**, according to an aspect of the present disclosure. The third exemplary spinal support device **300** is another exemplary implementation of a wearable article constructed according to the principles disclosed herein.

[0043] As best seen in **FIGS. 27 to 29**, the third spinal support device **300** comprises a biomechanically stiff trapezius grapnel **312** adapted to extend over and engage human trapezius muscles from a dorsal position toward a ventral position, a penannular cervical spine support portion **302** coupled to and supported by the trapezius grapnel **312**, and a harness **395** (see **FIGS. 36 and 37**). The term "biomechanically stiff, as used herein, means sufficiently rigid to transmit the majority of applied force while absorbing a minor portion of the applied force by deformation. In this sense, the term "biomechanically stiff" means stiff in the same sense that thick fibrocartilage is stiff, and the term "biomechanically stiff" implies less rigidity (more flexibility) than the term "biomechanically rigid". The trapezius grapnel **312** may be made from, for example, silicone, rubber, or suitable polymer materials.

[0044] The penannular shape of the cervical spine support portion **302** (best seen in **FIG. 31**) allows it to cradle the cervical spine portion of a subject's neck, as shown in **FIGS. 27 to 29**. The cervical spine support portion **302** comprises a series of biomechanically stiff vertebra supports **340** and a series of symphyseal resistive dampers **342**. Like the trapezius grapnel **312**, the biomechanically stiff vertebra supports **340** may be made from, for example, silicone, rubber, or suitable polymer materials, which may be the same material, used for the trapezius grapnel **312** or a different material. The vertebrae supports **340** are more rigid than the material used for the symphyseal resistive dampers **342**. The symphyseal resistive dampers **342** may be formed, for example, from an elastomeric material or a suitable force-reactive polymer. The vertebra supports **340** are spaced from one another by symphyseal resistive joints formed by the symphyseal resistive dampers **342**. Each of the vertebra supports **340** is a frame element forming part of a force-directing frame which, as can be seen in the drawings, is anatomically complementary to the human cervical spine, which comprises hard tissue (vertebrae) and soft tissue (e.g. muscle, intervertebral discs). These frame elements (vertebra supports **340**) form the deformable regions within the frame, that is, the spaces between the vertebra supports **340**, and the energy-absorbing material that makes up the symphyseal resistive dampers **342** is disposed in those deformable regions. More particularly, one of the symphyseal resistive dampers **342** extends between each adjacent pair of vertebra supports **340** so that the vertebra supports **340** alternate with the symphyseal resistive joints formed by the symphyseal resistive dampers **342**. Thus, the symphyseal resistive dampers **342** are engaged with the force-directing frame that comprises the vertebra supports **340** to absorb forces therefrom. As can be seen in **FIGS. 27 to 29**, the distal symphyseal resistive damper **342**, that is, the symphyseal resistive damper **342** that is furthest from the trapezius grapnel **312** relative to the other symphyseal resistive dampers **342**, is further distal from the trapezius grapnel **312** than the distal vertebra support **340**, that is, the vertebra support **340** that is

furthest from the trapezius grapnel **312** relative to the other vertebra supports **312**.

[0045] As will be explained in greater detail below, the harness **395** (see **FIGS. 36** and **37**) is mechanically coupled to the trapezius grapnel and is adapted to snugly anchor onto a human torso to maintain engagement of the trapezius grapnel with the human trapezius muscles and thereby maintain correct anatomical positioning of the third spinal support device **300**.

[0046] As best seen in **FIG. 30**, in the exemplary third spinal support device **300**, the symphyseal resistive dampers **342** are formed by ridges **344** on a monolithic collar member **346** formed from energy-absorbing material, with the distal symphyseal resistive damper **342** forming the cranial end **347** of the monolithic collar member **346**. The monolithic collar member **346** may be formed, for example, from an elastomeric material or a suitable force-reactive polymer. In the illustrated embodiment, the ridges **344** include longitudinal gaps **348** which divide each symphyseal resistive damper into a plurality of discrete symphyseal resistive elements **350**. The longitudinal gaps **348** provide for flexibility, stretching, and articulation of the collar member and, in the illustrated embodiment, extend beyond the ridges into the underlying substrate **352** of the monolithic collar member **346**. The vertebra supports **340** are disposed in the longitudinally extending channels **354** between the ridges **344**. Thus, the force-directing frame comprises a plurality of discrete force-directing elements (vertebra supports **340**) spaced from one another by the symphyseal resistive dampers **342** extending between adjacent ones of the discrete force-directing elements, and the monolithic collar member **346** also includes a recessed region **356** at the caudal end **358** thereof, e.g., the end opposite the cranial end **347**, which receives the trapezius grapnel **312**. Thus, the monolithic collar member **346** extends from the trapezius grapnel **312** at the caudal end **358** of the monolithic collar member **346** to and including the distal symphyseal resistive damper **342** forming the cranial end **347** of the monolithic collar member **346**. An additional symphyseal resistive damper **342** is formed between the trapezius grapnel **312** and the proximal vertebra support **340**, that is, the vertebra support **340** that is closest to the trapezius grapnel **312** relative to the other vertebra supports **312**.

[0047] The use of the monolithic collar member **346** to form the symphyseal resistive dampers **342** represents merely one exemplary embodiment. In other embodiments, the collar member and the symphyseal resistive dampers may be separate and discrete (e.g. non-monolithic) components. For example, the symphyseal resistive dampers may comprise separate pieces bonded to or otherwise secured on a collar member.

[0048] As can be seen in **FIGS. 27** to **29**, the vertebra supports **340** and the symphyseal resistive joints formed by the symphyseal resistive dampers **342** are sized and positioned for dorsal alignment with respective alternating human vertebrae **360**. As shown in **FIGS. 27** to **29**, the C1 vertebra (atlas bone) is denoted by reference **360A**, the C2 vertebra is denoted by reference **360B**, the C3 vertebra is denoted by reference **360C**, the C4 vertebra is denoted by reference **360D**, the C5 vertebra is denoted by reference **360E**, the C6 vertebra is denoted by reference **360F**, the C7 vertebra is denoted by reference **360G** and the T1 vertebra is denoted by reference **360H**. Embodiments of the third exemplary spinal support device **300** may be

provided in a number of different sizes to accommodate individuals of different ages, heights, sizes, and genders. For a given size of spinal support device 300, the exact alignment of the vertebra supports 340 and the symphyseal resistive joints formed by the symphyseal resistive dampers 342 with the vertebrae 360 will depend on a number of factors, including the size of the wearer's trapezius muscles and the length of the wearer's neck. Thus, for the same size of spinal support device 300, the alignment may be shifted relatively cranially or relatively caudally from one subject to another. FIGS. 27 and 28 show a relatively more cranial alignment in which the vertebra supports 340 are in registration with and positioned to dorsally cradle the C2 vertebra 360B, the C4 vertebra 360D and the C6 vertebra 360F, and the symphyseal resistive joints formed by the symphyseal resistive dampers 342 are in registration with and positioned to dorsally cradle the C3 vertebra 360C, the C5 vertebra 360E and the C7 vertebra 360G. FIG. 29 shows a relatively more caudal alignment in which the vertebra supports 340 are in registration with and positioned to dorsally cradle the C3 vertebra 360C, the C5 vertebra 360E and the C7 vertebra 360G, and the resistive joints formed by the symphyseal resistive dampers 342 are in registration with and positioned to dorsally cradle the C4 vertebra 360D, the C6 vertebra 360F and the T1 vertebra 360H.

[0049] In both the relatively more cranial alignment (FIGS. 27 and 28) and the relatively more caudal alignment (FIG. 29), the relative positions of the trapezius grapnel 312, the vertebra supports 340 and the symphyseal resistive joints formed by the symphyseal resistive dampers 342 allow the cervical spine support portion 302 to mimic the natural articulation of a human spine. Similarly to the first and second exemplary spinal support devices 100, 200, the symphyseal resistive joints formed by the symphyseal resistive dampers 342 provide increasing resistance as they undergo increasing deformation in response to an applied force causing flexion/extension/rotation of the spine and can thereby reduce angular/rotational acceleration (whiplash) of the head and neck from impact to the head or body. Thus, the frame elements (vertebra supports 340 as well as the flange portion 270 described below) are configured to divert at least a portion of the internal contortion forces within the cervical spine through the frame elements to the deformable regions (symphyseal resistive dampers 342 as well as symphyseal resistive flange portion 368). The energy-absorbing material forming the symphyseal resistive dampers 342 and the symphyseal resistive flange portion 368 damps the diverted internal contortion forces by deformation of the rate-sensitive material. Accordingly, when the third spinal support device 300 is secured on a wearer's neck, at least a portion of the forces applied to the hard tissue (vertebrae) are diverted away from the soft tissue (e.g. muscle, intervertebral discs) to the dampers (symphyseal resistive dampers 342 and symphyseal resistive flange portion 368) by transfer of the forces from the hard tissue through the force-directing frame (vertebra supports 340 as well as the flange portion 270) to the dampers whereby the dampers absorb the transferred portion of the forces and thereby limit internal forces applied to the soft tissue by the hard tissue.

[0050] In order to couple movement of a subject's head to the third spinal support device 300, the third spinal support device 300 further comprises an atlas support flange 362 that is mechanically coupled to and supported by the cervical spine support portion 302 distal from the trapezius grapnel 312. The atlas support flange 362 is disposed cranially of the cranial end

347 of the collar member **346** and extends dorsally outwardly therefrom so that, when the third exemplary spinal support device **300** is worn, the atlas support flange **362** will be interposed between the wearer's occipital bone **364** and the distal symphyseal resistive damper **342**, generally in registration with the wearer's atlas bone **360A**. The atlas support flange **362** provides a mechanical linkage between the wearer's occipital bone **364** and the distal symphyseal resistive damper **342** so that when the wearer's head moves (e.g. pivots) dorsally, such as from an impact, energy is transferred from the wearer's skull through the atlas support flange **362** to the distal symphyseal resistive damper **342** and thereby to the cervical spine support portion **302**. In some embodiments, such as for sports where no helmet is worn, the atlas support flange **362** may directly engage the wearer's head; in other embodiments, such as for helmeted sports, the atlas support flange **362** may engage the helmet, for example at the dorsal base of the helmet. The atlas support flange **362** may have different sizes or shapes depending on its intended use. For example, as shown in **FIGS. 32A** and **32B**, an atlas support flange **362** that is intended for use in hockey (**FIG. 32A**) may have a smaller volume than one intended for use in American/Canadian football (**FIG. 32B**). The atlas support flange **362** enables the third exemplary spinal support device to be used with standard, unmodified helmets.

[0051] In the illustrated embodiment, as best seen in **FIGS. 32A** and **32B**, the atlas support flange **362** comprises a symphyseal resistive flange portion **368** and a semi-rigid resilient flange portion **370** which, when the atlas support flange **362** is engaged with the cervical spine support portion **302**, is interposed between the symphyseal resistive flange portion **368** and the distal symphyseal resistive damper **342**. The symphyseal resistive flange portion **368** may be made from the same material as the collar member **346**, for example, from an elastomeric material or a suitable force-reactive polymer. The semi-rigid resilient flange portion **270** may be made from, for example, suitable flexible polymers. The semi-rigid resilient flange portion **270** is also a frame element, and assists in energy transfer from the skull or helmet through the atlas support flange **262** to the distal symphyseal resistive damper **342**. The symphyseal resistive flange portion **368** also provides progressively increasing resistance to deformation, and can thereby provide further mechanical resistance to (e.g. braking/deceleration of) of whiplash-related and concussion-related movement.

[0052] As shown in **FIG. 30**, in the illustrated embodiment the atlas support flange **362** is integrated with and extends outwardly from a liner **372** disposed on an innermost surface of the cervical spine support portion **302** such that, in use, the liner **372** will be positioned between the wearer's neck and the cervical spine support portion **302**. In the illustrated embodiment, the liner comprises a frame **373** (**FIG. 30**) and a plurality of discrete, spaced apart resilient members **374** laminated within an envelope of breathable mesh **376** (see **FIGS. 32A** and **32B** - the breathable mesh envelope **376** is not shown in **FIGS. 30** and **31** for clarity of illustration). The breathable mesh **376** and the spacing between the resilient members **374** facilitate airflow along the subject's neck to improve comfort when wearing the spinal support device **300**. In a preferred embodiment, as shown in the drawings, the atlas support flange **362**, including both the symphyseal resistive flange portion **268** and the semi-rigid resilient flange portion **370**, is generally L-shaped in cross-section and includes a depending brace **378**

forming part of the liner 372, and is encapsulated within the breathable mesh 376 along with the resilient members 374. In a preferred embodiment, the liner 372, and therefore the atlas support flange 362, is selectively engageable with and disengageable from the cervical spine support portion 302, and to assist in fitting the spinal support device 300 to a subject, liners 372 may be provided with different thicknesses by using resilient members 374 and a depending brace 378 of desired thickness. The liner 372 may be engaged with and disengaged from the cervical spine support portion 302 in a number of ways, including friction and/or pressure between a wearer's neck and the inner surface of the cervical spine support portion 302 or positive engagement mechanisms such as hook-and-loop fasteners or snap fasteners, among others. Thus, the spinal support device 300 has an engagement surface that conforms to external surface contours of the subject's neck.

[0053] With reference now to FIGS. 33 to 35, in a preferred embodiment the spinal support device 300 further comprises a resilient C-shaped retainer 380 engaging the monolithic collar member 346. The retainer 380 assists in returning the cervical spine support portion 302 to its neutral penannular shape following distortion, such as from movement by a wearer. In the illustrated embodiment, the retainer 380 comprises a curved central open scutiform frame 382 having two outwardly extending arms 384, and two outer H-frames 386 whose crossbars 388 are coupled to the arms 384 of the central open scutiform frame 382 by fasteners 390 such as rivets or the like. The fasteners 390 extend through the arms 384 of the central open scutiform frame 382, through the crossbars 388 of the outer H-frames 386 and through the monolithic collar member 346. The retainer 380 may be made from, for example, a suitable flexible polymer. As shown in FIGS. 30 and 33, the retainer 380, the vertebra supports 340 and the monolithic collar member 346 may all be laminated between inner and outer layers 392, 394 of textile, fabric, or similar material so as to provide the cervical spine support portion 302 with an exterior sheath. In the illustrated embodiment, lamination between the inner and outer layers 392, 394 secures the trapezius grapnel 312 and the other vertebra supports 312 in position on the monolithic collar member 346, and a layer of thermoplastic polyurethane (TPU) is coated onto the exterior surface of the exterior sheath formed by the inner and outer layers 392, 394 to provide further structural reinforcement. Other techniques, such as adhesive or bonding, may also be used to secure the trapezius grapnel 312 and the other vertebra supports 312 on the monolithic collar member 346.

[0054] As noted above, the third spinal support device 300 further comprises a harness 395 (not shown in FIG. 30; see FIGS. 36 and 37), which is secured to the cervical spine support portion 302 to maintain correct anatomical positioning of the third spinal support device 300. Thus, the harness 395 serves as a fastener adapted to secure the wearable article (spinal support device 300) externally and non-invasively on the subject in registration with the cervical spine in close topographical engagement the surface contours of the neck so that forces are transferred from the hard tissues (vertebrae) to the force-directing frame (vertebra supports 340 as well as the flange portion 270). Like the first and second exemplary spinal support devices 100, 200, the third exemplary spinal support device 300 may be integrated into a torso article such as a vest, compression shirt, or the like. For example, as shown in FIGS. 36 and 37, the harness 395 to which the cervical spine support portion 302 is formed from (TPU) and

is laminated or otherwise suitably secured to a shirt **396** or similar article. In the illustrated embodiment, the harness **395** is secured to the cervical spine portion **302** by attachment, for example by stitching, to the exterior sheath formed by the inner and outer layers **392**, **394** (**FIG. 30**) with further structural reinforcement being provided by bonding the harness to the layer of TPU disposed on the exterior surface of the exterior sheath. In other embodiments, the harness may be made from other suitable materials. Moreover, the harness design shown in the drawings, which loops across the chest, under the arms and between the shoulder blades so as to encircle the torso, is merely exemplary harness arrangement, and any suitable harness arrangement which provides snug anchoring to the torso may be used.

[0055] The spinal support device **300** is preferably provided with a throat band **397** extending across an aperture **398** of the cervical spine support portion. For example, the throat band **397** may be stitched to or otherwise secured to the exterior sheath formed by the inner and outer layers **392**, **394** of material, and may be elasticized or otherwise resilient or may take the form of a strap provided with a buckle or other fastener. In some embodiments, for example where the spinal support device **300** is intended for use in ice hockey, the throat band **397** and the inner and outer layers **392**, **394** may be made from a suitable cut-resistant material. For example, certain sports may require throat protection meeting certain cut-resistance standards.

[0056] Reference is now made to **FIGS. 38** to **48B**, which show another exemplary wearable article in the form of a fourth exemplary spinal support device **400**. In the fourth exemplary spinal support device **400**, a force-directing frame **402** is formed by two spaced-apart curved frame elements, namely a cranial frame element **404A** and a caudal frame element **404B**, which are shaped and dimensioned to be anatomically complementary to the anterior and lateral portions of a human neck (e.g. cervical spine region). The frame elements **404A**, **404B** are coupled to a quantity of rate-sensitive material **406** in the form of a monolithic penannular collar member **408** which is also shaped and dimensioned to be anatomically complementary to the anterior and lateral portions of a human neck. Certain exemplary techniques for coupling the frame elements **404A**, **404B** to the rate-sensitive material **406** will be described further below.

[0057] The frame elements **404A**, **404B** form three deformable regions **410A**, **410B**, **410C** within the force-directing frame **402**, with the rate-sensitive material **406** disposed within the deformable regions **410A**, **410B**, **410C**. A superior deformable region **410A** is formed superiorly (cranially) of the cranial frame element **404A**, an inferior deformable region **404B** is formed inferiorly (caudally) of the caudal frame element **404B** and an intermediate deformable region **410C** is formed between the cranial frame element **404A** and the caudal frame element **404B**. A portion of the rate-sensitive material **406** forming the collar member **408** is disposed within each of the superior deformable region **410A**, the inferior deformable region **404B** and the intermediate deformable region **410C**. When the fourth exemplary spinal support device **400** is secured on the subject's neck, the frame elements **404A**, **404B** will divert at least a portion of the internal contortion forces within the neck through one or both of the frame elements **404A**, **404B** to one or more of the superior deformable region **410A**, the inferior

deformable region **404B** and the intermediate deformable region **410C**. The rate-sensitive material **406** in the superior deformable region **410A**, the inferior deformable region **404B** and/or the intermediate deformable region **410C** thereby damps the diverted internal contortion forces by deformation of the rate-sensitive material **406** therein.

[0058] As shown in **FIGS. 40** and **41**, the fourth exemplary spinal support device **400** is secured externally and non-invasively on the subject in registration with the neck and in close topographical engagement therewith by way of a fastener comprising a compression shirt **420** with an integrated harness **422**, which arrangement will be described further below.

[0059] Referring now specifically to **FIGS. 38** and **39**, in the fourth exemplary spinal support device **400** the force-directing frame **402** and the rate-sensitive material **406** are encapsulated within an envelope **430** formed by a molded foam overlay **432** and a dorsal liner **434** formed from a suitable textile material (e.g. a resilient textile such as that marketed under the brand name Lycra[®]) and which may be secured to the overlay **432** by stitching or other suitable technique. The use of the overlay **432** allows the dorsal liner **434** to better conform to the shape of the collar member **408** without the textile material "tenting"; in other embodiments the foam overlay may be omitted and the collar member **408** may be molded directly onto a textile layer. While the overlay **432** may provide some additional structure and/or impact protection depending on the material, the primary functionality of the spinal support device **400** is provided by the cooperation of the force-directing frame **402** and the rate-sensitive material **406**. The fourth exemplary spinal support device **400** may be secured to the compression shirt **420** by binding, as shown in **FIG. 39**, by overlock as shown in **FIG. 39A**, by cover stitch as shown in **FIG. 39B**, or by any other suitable technique.

[0060] Reference is now made to **FIGS. 42** through **48B**. As best seen in **FIGS. 42** through **45**, in preferred embodiments the fourth exemplary spinal support device **400** further comprises a ventral liner **440** extending across the opening of the collar member **408** and secured to the compression shirt **420**. In the illustrated embodiment, the fourth exemplary spinal support device **400** is adapted for use in ice hockey and the ventral liner **440** is a cut-resistant liner. More particularly, in the illustrated embodiment the ventral liner **440** comprises an inner layer **442** of resilient textile (e.g. Lycra[®]) secured to the dorsal liner **434** and an outer layer **444** of resilient textile secured to the overlay **432**, and a layer of cut-resistant fabric **446** conforming to applicable regulations is disposed between the inner layer **442** and the outer layer **444** and secured to the overlay **432**. The inner layer **442** and outer layer **444** may each be a separate piece as shown in **FIG. 46A**, or may be formed from a single piece folded over the cut-resistant fabric **446** as shown in **FIG. 46B**.

[0061] As noted above, the fourth exemplary spinal support device **400** is secured by way of a fastener comprising a compression shirt **420** with an integrated harness **422**. As best seen in **FIGS. 42** to **45** and **47** to **48B**, the fastener further comprises opposed adjustment straps **450** that are secured to the overlay **432** as well as to the cut-resistant fabric **446**. As shown in **FIG. 47**, the adjustment straps **450** cross over the subject's chest and the ends of the adjustment straps **450** may be adjustably affixed to the integrated harness **422** on the compression shirt

420 by way of mating hook-and-loop fastener material **452** such as that marketed under the brand name Velcro[®]. **FIGS. 48A** and **48B** show exemplary constructions for the adjustment straps **450** and for the compression shirt **420** and integrated harness **422**, respectively. As shown in **FIG. 48A**, in the exemplary embodiment each adjustment strap **450** comprises a laminate **454** formed from three layers of resilient textile (e.g. Lycra[®]) bonded together by TPU layers interposed between the textile layers, with a hook or loop fabric patch **456** bonded to the end of the adjustment strap **450** by a correspondingly sized layer **458** of TPU film. As shown in **FIG. 48B**, the harness **422** comprises a TPU overlay **460** bonded to the fabric of the compression shirt **420** and a hook or loop fabric patch **462** (mated to the hook or loop fabric patch **456** on the adjustment strap **450**) bonded to the TPU overlay **460** by a correspondingly sized layer **464** of TPU film. In some instances, the adjustment straps **450** allow the spinal support device to be snugly fitted onto the neck and/or torso of the subject. In some instances, the snug fit of the spinal support device provides support to the head, neck, and/or spine without requiring the spinal support device to be coupled to a helmet.

[0062] Reference is now made to **FIGS. 49** through **54B**, which show two exemplary methods for forming the frame elements **404A**, **404B** and the collar member **408** of rate-sensitive material **406** and coupling them together. In each case, the frame elements **404A**, **404B** are overmoulded to an exterior layer **470** comprising a resilient textile (e.g. Lycra[®]) with a TPU film; the exterior layer will replace the overlay **432**. The exterior layer **470** with overmoulded frame elements **404A** and **404B** is and then placed in a mould, and the dorsal liner **434**, also comprising a resilient textile (e.g. Lycra[®]) with a TPU film, is also placed into the mould. The rate-sensitive material **406** is then added to the mould and formed into the collar member **408**. **FIGS. 49**, **51**, and **53** are included by way of reference to show the locations of the cross-sectional views in **FIGS. 50A**, **50B**, **52A**, **52B**, **53A**, and **53B**.

[0063] **FIGS. 50A**, **52A** and **54A** show a first arrangement in which the frame elements **404A**, **404B** are formed from a high density polyurethane foam and generally solid in cross-section along their length; **FIGS. 50B**, **52B** and **54B** show a second arrangement in which the frame elements **404A**, **404B** are formed from TPU having a generally channel-iron cross-section across their length.

[0064] **FIGS. 55** to **57** show an alternate structure for the compression shirt **420**, integrated harness **422**, and adjustment straps **450**.

[0065] **FIGS. 58** to **60** show other alternate structures for the compression shirt **420**, integrated harness **422**, and adjustment straps **450** of the spinal support device **400** of **FIG. 38**. In some instances, the spinal support device **400** comprises a cervical or neck support device, adjustment straps **450**, and an integrated harness **422**. In some instances, the spinal support device **400** is or comprises a cervical or neck support device and does not include adjustment straps **450** and/or an integrated harness **422**. **FIG. 58** provides a front perspective view of the spinal support device **400** with compression shirt **420**, integrated harness **422**, and adjustment straps **450**. **FIG. 59** provides a rear perspective view of the spinal support device **400** with

compression shirt **420**, integrated harness **422**, and adjustment straps **450**. **FIG. 60** provides front and rear views of the spinal support device **400** with compression shirt **420**, integrated harness **422**, and adjustment straps **450**. The spinal support device shown in **FIGS. 58 to 60** may be a variation on the spinal support device of **FIG. 38**. In some cases, the spinal support device comprises a cervical spinal support portion such as a collar as shown, for example, in **FIGS. 58 to 60**. In some instances, the spinal support device comprises a spinal support portion capable of supporting one or more regions of the non-cervical spine to complement the cervical spinal support portion. The regions of the spine include cervical, thoracic, lumbar, and sacral regions. The spinal support portion may comprise an upper spinal support portion and a lower spinal support portion. In some instances, the spinal support portion extends along the back or spine of a subject. In some instances, the spinal support portion extends along at least a portion, most or the full length of the back or spine of a subject. The spinal support portion may extend along at least 5%, 10%, 20%, 30%, 40%, 50%, 60%, 70%, 80%, 90%, 95%, or 99% a full length of the back of spine of the subject. In some instances, the spinal support portion extends along a partial length of the back or spine of a subject. In some instances, while the cervical spinal support portion protects at least the cervical region of the spine, the spinal support portion protects one or more of the thoracic, lumbar, and sacral regions of the spine. For example, in some instances, the spinal support portion protects the thoracic region of the spine. In some instances, the spinal support portion protects the thoracic and lumbar regions of the spine. In some instances, the spinal support portion protects the thoracic, lumbar, and sacral regions of the spine. In some instances, the spinal support portion provides partial spinal support such as, for example, upper spinal support or upper and middle spinal support. In some instances, the spinal support portion provides full spinal support. For example, the harness **422** may comprise the spinal support portion extending along the back of the subject wearing the harness. The spinal support portion may be positioned inferior to the cervical support portion. In some instances, the spinal support portion is coupled, attached, and/or integrated with the cervical support portion of the spinal support device. Alternatively, the spinal support portion is separate from the cervical support portion, and may instead be coupled, attached, and/or integrated with the harness itself. In some instances, the spinal support portion is separate from both the cervical support portion and the harness, and instead comprises its own fastener for being fit or worn by a subject. In some instances, the spinal support device does not comprise a spinal support portion. For example, the spinal support device **400** shown in **FIGS. 58 to 60** comprises a cervical support portion, a harness, and adjustment straps.

[0066] In some instances, the harness design shown in the drawings loops across the chest, under the arms, across the sides, and between the shoulder blades so as to encircle the torso to provide snug anchoring to the torso. The harness **422** may include loops across the chest, under the arms and between the shoulder blades so as to encircle the torso. The harness **422** may include a loop across the middle and/or lower back, as shown in **FIG. 59**, which is often integrated or coupled to a spinal support portion vertically positioned along the spine. In some instances, the harness is detachable from the collar and/or compression shirt. In some instances, the harness is not detachable from the collar and/or compression shirt. In some instances, the harness comprises an elastomeric overlay. In some instances, the harness

comprises a thermoplastic polyurethane (TPU) overlay.

[0067] In some instances, TPU comprises polyester TPU, polyether TPU, polycaprolactone TPU, or any combination thereof. In some instances, TPU comprises aromatic TPU, aliphatic TPU, or any combination thereof. TPU is a block copolymer composed of hard blocks (e.g., composed of a chain extender and isocyanate) and soft blocks (e.g., composed of polyol and isocyanate). Adjustment of the relative ratios of hard blocks and soft blocks allows for the generation of TPU with varying physical properties. In some instances, the harness is attached, coupled, adhered, or integrated to the compression shirt (or other article of clothing such as a shirt, jacket, or sweater) by lamination. In some instances, the harness is laminated onto the compression shirt. In some instances, the harness is laminated onto one or more layers of a material (e.g., Lycra) that is laminated onto the shirt. In some instances, the harness comprises one or more openings (e.g., gaps in the harness material) **465** for providing flexion and/or mobility. For example, in some instances, the harness comprises TPU configured to resist stretching. The harness can comprise one or more openings **465** at the rear to allow forward flexion and/or full range of motion. In some instances, the harness comprises one or more openings **465** at the front to allow backward flexion and/or full range of motion.

[0068] FIGS. **58** to **60** also show the integrated harness **422** having at least one side adjustment strap **455** integrated or coupled to the compression shirt **420**. In some instances, the at least one side adjustment strap **455** is secured to the overlay **432** as well as to the cut-resistant fabric **446**. As shown in FIG. **58**, a side adjustment strap **455** crosses over the subject's side or oblique, and the ends of the side adjustment strap may be adjustably affixed to the integrated harness **422** on the compression shirt **420** by way of mating hook-and-loop fastener material **452** such as that marketed under the brand name Velcro®. FIG. **60** shows exemplary constructions for two side adjustment straps and for the compression shirt **420** and integrated harness **422**, respectively. In some instances, the side adjustment strap **455** is attached to the harness as shown in FIG. **59**. Accordingly, the side adjustment strap **455** is able to secure the entire spinal support system (e.g., spinal support device, harness, and compression shirt) to the subject, and keep the spinal support device such as the collar in FIG. **58** in place, effectively balancing the front and rear tension of the harness around the subject. For example, the straps allow the subject to properly secure the device to the appropriate areas, with the comfort of subject-defined tension. In some instances, the side adjustment strap **455** is sewn onto the harness and/or compression shirt. In some instances, the side adjustment strap is attached along the dorsal (rear) side of the harness towards one end, and attaches to the ventral (front) side of the harness towards the other end using Velcro®. In some instances, the side adjustment strap is attached without using Velcro®, such as for example, a buckle.

[0069] In some embodiments, the spinal support device does not require certain structural elements to provide support and/or stability. For example, in some instances, the spinal support device does not comprise an exoskeleton and/or wearable articles. In some instances, the spinal support device does not comprise a hinge point. In some instances, the spinal

support device does not attach to a helmet. In some instances, the spinal support device does not comprise or attach to a compression shirt. In some instances, the spinal support device does not comprise or attach to a harness. In some instances, the spinal support device is coupled to a harness that is not integrated into a shirt or other article of clothing. In some instances, the harness is worn over a shirt or other article of clothing (e.g., compression shirt). In some instances, the spinal support device does not comprise adjustment straps.

[0070] Provided herein per **FIGS. 61A-62C** is an exemplary first compression article. **FIG. 61A** shows a front view of an exemplary first compression article, in accordance with some embodiments. **FIG. 61B** shows a back view of the exemplary first compression article of **FIG. 61A**. **FIG. 61C** shows a side view of the exemplary first compression article of **FIG. 61A**. **FIG. 61D** shows a detailed front view of the exemplary first compression article of **FIG. 61A**. **FIG. 61E** shows a detailed back view of the exemplary first compression article of **FIG. 61A**. **FIG. 61F** shows a detailed side view of the exemplary first compression article of **FIG. 61A**.

[0071] Shown in **FIGS. 61A-62C** is an exemplary first compression article **6100** comprising a base layer **6120**, a compression element, and a support element. As shown the support element comprises a neck support **6101**, a thigh support **6102**, a shin support **6103**, and a spine support **6104**. As shown the compression element comprises a chest compression **6105**, a shoulder compression **6106**, an elbow compression **6107**, a thigh compression **6108**, a knee compression **6109**, a shin compression **6110**, an ankle compression **6111**, and a waist compression **6112**. In some embodiments, the compression article **6100** further comprises a gripping element (not shown) on an interior surface of a base layer of the article.

[0072] As seen, the exemplary first compression article **6100** comprises one neck support **6101**, two thigh supports **6102**, two shin supports **6103**, one spine support **6104**, one chest compression **6105**, two shoulder compressions **6106**, two elbow compressions **6107**, two thigh compressions **6108**, two knee compressions **6109**, two shin compressions **6110**, two ankle compressions **6111**, one waist compression **6112** and one base layer **6120**. As used herein, support and support element have equivalent meaning and are used interchangeably. An article comprising any combination of the aforementioned support elements is contemplated herein. Alternatively, in some embodiments, the exemplary first compression article **6100** comprises 1, 2, 3, 4, 5, 6, 7, 8, 9, or 10 or more of each of the neck support **6101**, the thigh support **6102**, the shin support **6103**, the spine support **6104**, the chest compression **6105**, the shoulder compression **6106**, the elbow compression **6107**, the thigh compression **6108**, the knee compression **6109**, the shin compression **6110**, the ankle compression **6111**, the waist compression **6112**, the gripping element, or any combination thereof.

[0073] In some embodiments, at least one of a support element and a compression element are permanently or removably attached to the base layer **6120**. In some embodiments, at least one of the support element, the compression element, and the gripping element is laminated or printed adjacent to the base layer. In some embodiments, at least one of the support element, the compression element, and the gripping element is removably attached to the base layer **6120**. In some embodiments, at least one of the support element, the compression

element, and the gripping element is removably attached to the interior surface of the base layer 6120. In some embodiments, at least one of the support element and the compression element is attached to the exterior surface of the base layer 6120. In some embodiments, at least one of the support element, the compression element, and the gripping element is removably attached to the base layer 6120 by a fastener, optionally wherein the fastener comprises a strap a buckle, a hook and loop fastener, a zipper, a button, a hook, an eye, a lace, a magnet, a clasp, a clip, a screw, a bolt, a nut, a tie, or any combination thereof.

[0074] In some embodiments, at least one a support element and a compression element, the base layer 6120, and the gripping element are formed of fabric, thread, wood, fiberglass, carbon fiber, metal, a polymer, a gel, a foam, a composite, or any combination thereof. In some embodiments, the polymer comprises thermoplastic polyurethane, silicone, polyester, spandex, or any combination thereof. In some embodiments, at least two of a support element and a compression element, the base layer 6120, and the gripping element are formed of the same material. In some embodiments, at least two of a support element and a compression element, the base layer 6120, and the gripping element are formed of different materials.

[0075] In some embodiments, the at least one of the compression element comprises a polymeric material or composite material. In some embodiments, at least one of the compression elements comprises silicone, nylon, Lycra, rubber, neoprene, vinyl, polyurethane, or any combination thereof. In some embodiments, the at least one support element comprises an elastomeric polymer. In some embodiments, the at least one support element comprises a gel, a foam, a non-Newtonian fluid, or any combination thereof. In some embodiments, the foam comprises a non-Newtonian fluid. In some embodiments, the foam comprises a shear thickening non-Newtonian fluid. In some embodiments, the non-Newtonian foam is encapsulated within a pouch. In some embodiments, the non-Newtonian fluid is encapsulated in a pouch. In some embodiments, the non-Newtonian fluid comprises a shear thickening non-Newtonian fluid. In some embodiments, the at least one support element comprises a non-Newtonian foam and a non-Newtonian fluid. In some embodiments, the at least one support element comprises a Newtonian foam material positioned between the body surface of the subject and the non-Newtonian material.

[0076] A non-Newtonian material, or a rate-sensitive material, does not follow Newton's law of viscosity, and has a viscosity that is proportional to its instant or previous shear rate. A non-Newtonian material is generally classified as a shear-thinning or a shear-thickening non-Newtonian material, whereby the viscosity of shear-thinning and shear-thickening non-Newtonian materials decreases and increases under shear, respectively. The magnitude by which the viscosity of a fluid is altered by shear stress is referred to as a power rule number, wherein shear thickening non-Newtonian materials exhibit a power rule number of greater than 1, and wherein shear thinning non-Newtonian materials exhibit a power rule number of less than 1. Further, non-Newtonian materials can be classified as a non-Newtonian fluid or a non-Newtonian solid, which exist as a fluid or solid, respectively, under zero shear stress. In some embodiments, solid non-Newtonian materials can be easily incorporated into a wearable article.

[0077] In some embodiments, a force-reactive or rate-sensitive material comprises a foam material and a dilatant (e.g. non-Newtonian fluid). In some embodiments, the force-reactive material comprises a foam matrix. In some embodiments, the foam matrix is made up of a soft, elastomeric polymer. Examples of elastomeric polymers include polyurethane, polybutadiene, chloroprene, polychloroprene, neoprene, isobutylene and isoprene copolymer, styrene-butadiene copolymer, butadiene-acrylonitrile copolymer, ethylene-propylene copolymer, polyacrylic rubber, epichlorohydrin, fluoroelastomer, perfluoroelastomer, polyether block amides, ethylene-vinyl acetate, polysulfide rubber, and elastolefin. In some embodiments, the foam matrix comprises a solid foamed polymer. In some embodiments, the foam matrix comprises a synthetic polymer. In some embodiments, a dilatant is dispersed within the foam matrix. In some embodiments, the dilatant is present in the foam matrix at a percentage by volume (v/v) of at least about 5%, about 10%, about 15%, about 20%, about 25%, about 30%, about 35%, about 40%, about 45%, about 50%, about 55%, about 60%, about 65%, about 70%, about 75%, or about 80%. In some embodiments, the polyborodimethylsiloxane is present in the foam matrix at a percentage by volume (v/v) of at most about 5%, about 10%, about 15%, about 20%, about 25%, about 30%, about 35%, about 40%, about 45%, about 50%, about 55%, about 60%, about 65%, about 70%, about 75%, or about 80%.

[0078] An exemplary force-reactive or rate-sensitive material comprising a non-Newtonian fluid is a polyurethane foam comprising polyborodimethylsiloxane. In some embodiments, the force-reactive material comprises a foam material such as polyurethane foam and a dilatant. In some embodiments, the dilatant is a polymer-based material such as polyborodimethylsiloxane. In some embodiments, the polyborodimethylsiloxane is present in the foam matrix at a percentage by volume (v/v) of at least about 5%, about 10%, about 15%, about 20%, about 25%, about 30%, about 35%, about 40%, about 45%, about 50%, about 55%, or about 60%. In some embodiments, the polyborodimethylsiloxane is present in the foam matrix at a percentage by volume (v/v) of at most about 5%, about 10%, about 15%, about 20%, about 25%, about 30%, about 35%, about 40%, about 45%, about 50%, about 55%, or about 60%.

[0079] In some embodiments, the dilatant comprises colloidal silica particles suspended in polyethylene glycol. In some embodiments, the silica particles are suspended at a percentage by volume (v/v) of at least about 40%, about 45%, about 50%, about 55%, about 60%, about 65%, about 70%, about 75%, or about 80%. In some embodiments, the silica particles are suspended at a percentage by volume (v/v) of at most about 40%, about 45%, about 50%, about 55%, about 60%, about 65%, about 70%, about 75%, or about 80%.

[0080] Preferably, the rate-sensitive materials are solid materials (the term "solid" including foam), although the use of non-solid rate-sensitive materials is also contemplated. For example, a liquid rate-sensitive material may be encapsulated within an envelope that is impermeable to that liquid and used in wearable articles according to the present disclosure. In some embodiments, the solid rate-sensitive material comprises a foam matrix with a dispersed dilatant.

[0081] In some embodiments, at least one of the support element, the compression element, the gripping element, and the base layer 6120 comprises two or more layers. In some embodiments, at least one of the support element, the compression element, the gripping element, and the base layer 6120 is durable, waterproof, stain-proof, hypoallergenic, antibacterial, self-healing, heat resistant, friction resistant, or any combination thereof. In some embodiments, at least one of the support element, the compression element, the gripping element, and the base layer 6120 is formed of a polymeric material or composite material.

[0082] In some embodiments, the at least one support element is configured to provide stress relief, load transfer, fatigue relief, or any combination thereof to the wearer. In some embodiments, the at least one support element is configured to provide resistance to movement of at least one of a muscle, a joint, or a bone of a wearer, wherein the resistance increases with increasing force of the movement. In some embodiments, the at least one support element is configured to exert the force on at least one of the muscle, the joint, or the bone of a wearer throughout the wearer's full or partial range of motion in one or more degrees of freedom. In some embodiments, the force comprises a continuous force, a proportional force, a derivative force, or any combination thereof. In some embodiments, at least one of the proportional force and the derivative force is based on a linear position, an angular position, a velocity, or an acceleration of the bone, the muscle, or the joint of the wearer. In some embodiments, the muscle comprises a bicep, a triceps, a deltoid, a forearm, a thigh, a calf, a trapezius, a glute, a neck, a chest, an oblique, an upper back, a lower back, or an abdominal muscle. In some embodiments, the joint comprises an ankle, a knee, a hip, a spine, a wrist, an elbow, or a shoulder joint. In some embodiments, the bone comprises an ankle, a knee, a hip, a spine, a wrist, an elbow, a shoulder, a tibia, a fibula, an arm, a neck, or a rib bone. In some embodiments, the neck support comprises a penannular collar member that is anatomically complementary with a neck of the wearer. In some embodiments, the neck support comprises an elastomeric material or a force-reactive polymer positioned around a rear and lateral sides of a neck of the wearer. In some embodiments, at least one of the neck support, the spine support, the thigh support, and the shin support comprises a furrow. In some embodiments, at least one of the neck support, the spine support, the thigh support, and the shin support comprises a plurality of furrows comprising 2, 3, 4, 5, 6, 7, 8, 9, or 10 or more furrows. In some embodiments, two or more of the plurality of furrows have equivalent sizes or shapes. In some embodiments, two or more of the plurality of furrows have non-equivalent sizes or shapes. In some embodiments, the furrow is configured to flex or fold along a set line, arch, or plane. In some embodiments, the furrow is configured to prevent or inhibit motion of the wearer in one or more degrees of freedom. In some embodiments, the at least one compression element is configured to provide stress support, load transfer, fatigue relief, or any combination thereof to the wearer. In some embodiments, the at least one compression element is configured to exert a force on a muscle a bone, or a joint of a wearer. In some embodiments, the at least one compression element is configured to exert a force on muscle, bone, or joint of a wearer throughout a full or partial range of motion of the muscle, bone, or joint. In some embodiments, the force comprises a continuous force, a proportional force, a derivative force, or any combination thereof. In some embodiments, at least one of the proportional force and the derivative force are based on a linear position, an angular position,

a velocity, or an acceleration of the bone, the muscle, or the joint of the wearer. In some embodiments, the muscle comprises a bicep, a triceps, a deltoid, a forearm, a thigh, a calf, a trapezius, a glute, a neck, a chest, or abdominal muscle. In some embodiments, the joint comprises an ankle, a knee, a hip, a spine, a wrist, an elbow, or a shoulder joint. In some embodiments, the bone comprises an ankle, a knee, a hip, a spine, a wrist, an elbow, a shoulder, a tibia, a fibula, an arm, a neck, or a rib bone. In some embodiments, the article further comprises a harness secured to at least one support element. In some embodiments, the harness is integrated into the base layer. In some embodiments, the harness is laminated or printed adjacent to the base layer. In some embodiments, the article further comprises at least one adjustable tension element. In some embodiments, the at least one adjustable tension element comprises at least one of a chest tension element, an abdominal tension element, a waist tension element, a thigh tension element, or a shin tension element. In some embodiments, the at least one adjustable tension element comprises a strap, a fastener, a buckle, a hook and loop fastener, a zipper, a button, a hook, an eye, a lace, a magnet, a clasp, a clip, a screw, a bolt, a nut, a tie, or any combination thereof. In some embodiments, the article is a shirt, a pair of pants, or a full body suit. In some embodiments, the base layer has bilateral symmetry.

[0083] Shown in **FIGS. 61A-62E** is an exemplary first compression article **6100** comprising a base layer **6120** having an interior surface and an exterior surface. In some embodiments, the interior surface has a first coefficient of friction (μ) relative to a body surface of the subject. In some embodiments, the base layer **6120** has a first modulus of elasticity (E_1). In some embodiments, the at least one compression element has a second modulus of elasticity (E_2) that is greater than E_1 .

[0084] As seen in **FIGS. 61A, 61D, and 61E**, the neck support **6101** is configured to support the neck of a subject. In some embodiments, the neck support **6101** is configured to maintain continuous contact with the neck of a subject throughout the neck's full range of motion or partial range of motion. In some embodiments, the neck support **6101** is configured to exert a force on the neck of a subject throughout the neck's full range of motion or partial range of motion. In some embodiments, the neck support **6101** is configured to exert a continuous force, a proportional force, or a derivative force on the spine of a subject. In some embodiments, the force exerted by the neck support **6101** on the subject corresponds to at least one of the linear or angular position, velocity, and acceleration of the subject's neck. In some embodiments, the neck support **6101** contacts or is rigidly or flexibly connected to at least one of the spine support **6104**, the chest compression **6105**, the shoulder compression **6106**, and the base layer **6120**. In some embodiments, the neck support **6101** comprises one or more independent portions, wherein two or more of the independent portions are permanently or removably connected. In some embodiments, the two or more independent portions are rigidly or flexibly connected to each other.

[0085] In some embodiments, the at least one support element comprises a cervical support device. In some embodiments, the cervical support device comprises the neck support **6101**. In some embodiments, the cervical support device comprises the non-Newtonian material

integrated into the base layer by at least one laminated layer. In some embodiments, the cervical support device comprises an inner mesh liner positioned within an interior of the base layer in contact with a wearer's neck.

[0086] In some embodiments, the neck support **6101** has a thickness that is uniform in at least one of a radial direction and a linear direction. In some embodiments, the neck support **6101** has a nonuniform thickness. In some embodiments, the neck support **6101** has lateral symmetry. As seen in **FIG. 61E**, the neck support **6101** may comprise one or more furrows **6101a**. In some embodiments, the one or more furrows **6101a** are configured to flex or fold along a set line, arch, or plane. In some embodiments, the one or more furrows **6101a** are configured to prevent or allow motion of the neck in one or more directions. In some embodiments, two or more of the furrows **6101a** have equivalent sizes or shapes. In some embodiments, two or more of the furrows **6101a** have inequivalent sizes or shapes. In some embodiments, at least one of the furrows **6101a** lies generally parallel to a transverse plane of the subject. In some embodiments, at least one of the furrows **6101a** extends radially about the neck of the subject. In some embodiments, at least one of the furrows **6101a** extends radially and normally about the neck of the subject. In some embodiments, at least one of the furrows **6101a** terminates at an edge of the neck support **6101**. In some embodiments, at least one of the furrows **6101a** terminates without intersecting an edge of the neck support **6101**. As seen in **FIG. 61E**, the neck support **6101** comprises 4 furrows **6101a**. Alternatively, in some embodiments, the neck support **6101** comprises 1, 2, 3, 4, 5, 6, 7, 8, 9, or 10 or more furrows.

[0087] As seen in **FIGS. 61B** and **61E**, the spine support **6104** is configured to support the spine of a subject. In some embodiments, the spine support **6104** is configured to maintain continuous contact with the spine of a subject throughout the spine's full range of motion or partial range of motion. In some embodiments, the spine support **6104** is configured to exert a force on the spine of a subject throughout the spine's full range of motion or partial range of motion. In some embodiments, the spine support **6104** is configured to exert a continuous force, a proportional force, or a derivative force on the spine of a subject. In some embodiments, the force exerted by the spine support **6104** on the subject corresponds to at least one of the linear or angular position, velocity, and acceleration of the subject's spine. In some embodiments, the spine support **6104** contacts or is rigidly or flexibly connected to at least one of the neck support **6101**, the chest compression **6105**, the shoulder compression **6106**, the waist compression **6112**, and the base layer **6120**. In some embodiments, the spine support **6104** comprises one or more independent portions, wherein two or more of the independent portions are permanently or removably connected. In some embodiments, the two or more independent portions are rigidly or flexibly connected to each other.

[0088] In some embodiments, the spine support **6104** has a thickness that is uniform in at least one of a radial direction and a linear direction. In some embodiments, the spine support **6104** has a nonuniform thickness. In some embodiments, the spine support **6104** has lateral symmetry. As seen in **FIG. 61E**, the spine support **6104** may comprise one or more furrows **6104a**. In some embodiments, the one or more furrows **6104a** are configured to flex or fold along a set line, arch, or plane. In some embodiments, the one or more furrows **6104a** are

configured to prevent or allow motion of the spine in one or more directions. In some embodiments, two or more of the furrows **6104a** have equivalent sizes or shapes. In some embodiments, two or more of the furrows **6104a** have inequivalent sizes or shapes. In some embodiments, at least one of the furrows **6104a** lies generally parallel to a transverse plane of the subject. In some embodiments, at least one of the furrows **6104a** extends radially about the spine of the subject. In some embodiments, at least one of the furrows **6104a** extends radially and normally about the spine of the subject. In some embodiments, at least one of the furrows **6104a** terminates at an edge of the spine support **6104**. In some embodiments, at least one of the furrows **6104a** terminates without intersecting an edge of the spine support **6104**. As seen in FIG. 61E, the spine support **6104** comprises 4 furrows **6104a**. Alternatively, in some embodiments, the spine support **6104** comprises 1, 2, 3, 4, 5, 6, 7, 8, 9, or 10 or more furrows.

[0089] As seen in FIGS. 61A-C, the thigh support **6102** of the first exemplar compression article is configured to protect at least one of the thigh and the underlying hip bones of a subject. In some embodiments, the thigh support **6102** is configured to maintain continuous contact with the thigh of a subject throughout the thigh's full range of motion or partial range of motion. In some embodiments, the thigh support **6102** is configured to exert a continuous force on the thigh of a subject throughout the thigh's full range of motion or partial range of motion. In some embodiments, the force exerted by the thigh support **6102** on the subject corresponds to at least one of the linear or angular position, velocity, and acceleration of the subject's thigh. In some embodiments, the thigh support **6102** contacts or is rigidly or flexibly connected to at least one of the spine support **6104**, the shin support **6103**, the waist compression **6108**, the knee compression **6109**, the thigh compression **6112**, and the base layer **6120**. In some embodiments, the thigh support **6102** comprises one or more independent portions, wherein two or more of the independent portions are permanently or removably connected. In some embodiments, the two or more independent portions are rigidly or flexibly connected to each other.

[0090] In some embodiments, the thigh support **6102** has a thickness that is uniform in at least one of a radial direction and a linear direction. In some embodiments, the thigh support **6102** has a nonuniform thickness. In some embodiments, the thigh support **6102** has lateral symmetry. In some embodiments, the thigh support **6102** comprises a left thigh support and a right thigh support configured for use on the left and right side of the subject, respectively. In some embodiments, the left thigh support is equivalent to the right thigh support. In some embodiments, the left thigh support is a mirrored equivalent of the right thigh support about one or more planes.

[0091] As seen in FIGS. 61A-C, the shin support **6103** is configured to protect at least one of the shin and the underlying leg bones of a subject. In some embodiments, the shin support **6103** is configured to maintain continuous contact with the shin of a subject throughout the shin's full range of motion or partial range of motion. In some embodiments, the shin support **6103** is configured to exert a continuous force on the shin of a subject throughout the shin's full range of motion or partial range of motion. In some embodiments, the force exerted by the

shin support **6103** on the subject corresponds to at least one of the linear or angular position, velocity, and acceleration of the subject's shin. In some embodiments, the shin support **6103** contacts or is rigidly or flexibly connected to at least one of the spine support **6104**, the thigh support **6103**, the ankle compression **6111**, the knee compression **6109**, the shin compression **6112**, and the base layer **6120**. In some embodiments, the shin support **6103** comprises one or more independent portions, wherein two or more of the independent portions are permanently or removably connected. In some embodiments, the two or more independent portions are rigidly or flexibly connected to each other.

[0092] In some embodiments, the shin support **6103** has a thickness that is uniform in at least one of a radial direction and a linear direction. In some embodiments, the shin support **6103** has a nonuniform thickness. In some embodiments, the shin support **6103** has lateral symmetry. In some embodiments, the shin support **6103** comprises a left shin support and a right shin support configured for use on the left and right side of the subject, respectively. In some embodiments, the left shin support is equivalent to the right shin support. In some embodiments, the left shin support is a mirrored equivalent of the right shin support about one or more planes.

[0093] As seen in FIGS. 61A-C, the shin support **6103** is configured to protect at least one of the shin and the underlying leg bones of a subject. In some embodiments, the shin support **6103** is configured to maintain continuous contact with the shin of a subject throughout the shin's full range of motion or partial range of motion. In some embodiments, the shin support **6103** is configured to exert a continuous force on the shin of a subject throughout the shin's full range of motion or partial range of motion. In some embodiments, the force exerted by the shin support **6103** on the subject corresponds to at least one of the linear or angular position, velocity, and acceleration of the subject's shin. In some embodiments, the shin support **6103** contacts or is rigidly or flexibly connected to at least one of the spine support **6104**, the thigh support **6103**, the ankle compression **6111**, the knee compression **6109**, the shin compression **6112**, and the base layer **6120**. In some embodiments, the shin support **6103** comprises one or more independent portions, wherein two or more of the independent portions are permanently or removably connected. In some embodiments, the two or more independent portions are rigidly or flexibly connected to each other.

[0094] In some embodiments, the shin support **6103** has a thickness that is uniform in at least one of a radial direction and a linear direction. In some embodiments, the shin support **6103** has a nonuniform thickness. In some embodiments, the shin support **6103** has lateral symmetry. In some embodiments, the shin support **6103** comprises a left shin support and a right shin support configured for use on the left and right side of the subject, respectively. In some embodiments, the left shin support is equivalent to the right shin support. In some embodiments, the left shin support is a mirrored equivalent of the right shin support about one or more planes.

[0095] As shown in FIG. 61C, the exemplary first compression article **6100** comprises a chest compression **6105**, a shoulder compression **6106**, an elbow compression **6107**, a thigh

compression **6108**, a knee compression **6109**, a shin compression **6110**, an ankle compression **6111**, and a waist compression.

[0096] As shown in **FIG. 61C**, the chest compression **6105** is configured to maintain at least one of a position and a pressure of the first compression article **6100** on the chest of the subject. In some embodiments, the chest compression **6105** is configured to maintain at least one of a position and a pressure of the neck support **6101** against the neck of the subject, the spine support **6104** against the spine of the subject, or both. In some embodiments, the chest compression **6105** is configured to maintain continuous contact with the chest of a subject throughout the chest's full range of motion or partial range of motion. In some embodiments, the chest compression **6105** is configured to exert a continuous force on the chest of a subject throughout the chest's full range of motion or partial range of motion. In some embodiments, the force exerted by the chest compression **6105** on the subject corresponds to at least one of the linear or angular position, velocity, and acceleration of the subject's chest. In some embodiments, the chest compression **6105** contacts or is rigidly or flexibly connected to at least one of the spine support **6104**, the neck support **6101**, and the base layer **6120**.

[0097] As shown in **FIG. 61A** and **C**, the chest compression **6105** is configured to surround the right shoulder, the left shoulder, and the neck of the subject. Alternatively, in some embodiments, the chest compression **6105** is configured surround at least one of the right shoulder, the left shoulder, and the neck of the subject. Per **FIG. 61A** and **C**, the chest compression **6105** bifurcates and coalesces beneath and above each shoulder of the subject. Alternatively, in some embodiments, the chest compression **6105** is contiguous beneath and above each shoulder of the subject, or splits into multiple segments above each shoulder of the subject.

[0098] As shown in **FIGS. 61C**, the shoulder compression **6106** is configured to maintain at least one of a position and a pressure of the first compression article **6100** on the shoulder of the subject. In some embodiments, the shoulder compression **6106** is configured to maintain continuous contact with the shoulder of a subject throughout the shoulder's full range of motion or partial range of motion. In some embodiments, the shoulder compression **6106** is configured to exert a continuous force on the shoulder of a subject throughout the shoulder's full range of motion or partial range of motion. In some embodiments, the force exerted by the shoulder compression **6106** on the subject corresponds to at least one of the linear or angular position, velocity, and acceleration of the subject's shoulder.

[0099] As shown in **FIG. 61C**, the shoulder compression **6106** is configured surround at least a portion of the right shoulder or the left shoulder of the subject. Alternatively, in some embodiments, the shoulder compression **6106** is configured surround at least one of the right shoulder, the left shoulder, and the neck of the subject. In some embodiments, the shoulder compression **6106** is continuous. In some embodiments, the shoulder compression **6106** bifurcates and coalesces at least once. In some embodiments, the shoulder compression **6106** comprises a left shoulder compression **6106** and a right shoulder compression **6106** configured for use on the left and right shoulder of the subject, respectively. In some

embodiments, the left shoulder compression **6106** is equivalent to the right shoulder compression **6106**. In some embodiments, the left shoulder compression **6106** is a mirrored equivalent of the right shoulder compression **6106** about one or more planes.

[0100] As shown in **FIG. 61C**, the shoulder compression **6106** is configured to maintain at least one of a position and a pressure of the first compression article **6100** on the shoulder of the subject. In some embodiments, the shoulder compression **6106** is configured to maintain continuous contact with the shoulder of a subject throughout the shoulder's full range of motion or partial range of motion. In some embodiments, the shoulder compression **6106** is configured to exert a continuous force on the shoulder of a subject throughout the shoulder's full range of motion or partial range of motion. In some embodiments, the force exerted by the shoulder compression **6106** on the subject corresponds to at least one of the linear or angular position, velocity, and acceleration of the subject's shoulder.

[0101] As shown in **FIG. 61C**, the shoulder compression **6106** is configured surround at least a portion of the right shoulder or the left shoulder of the subject. Alternatively, in some embodiments, the shoulder compression **6106** is configured surround at least one of the right shoulder, the left shoulder, and the neck of the subject. In some embodiments, the shoulder compression **6106** is continuous. In some embodiments, the shoulder compression **6106** bifurcates and coalesces at least once. In some embodiments, the shoulder compression **6106** comprises a left shoulder compression **6106** and a right shoulder compression **6106** configured for use on the left and right shoulder of the subject, respectively. In some embodiments, the left shoulder compression **6106** is equivalent to the right shoulder compression **6106**. In some embodiments, the left shoulder compression **6106** is a mirrored equivalent of the right shoulder compression **6106** about one or more planes.

[0102] **FIGS. 62A-C** show the adjustable tension areas of an exemplary first compression article. **FIG. 62A** shows a front view of the adjustable tension areas of the exemplary first compression article of **FIG. 61A**, in accordance with some embodiments. **FIG. 62B** shows a back view of the adjustable tension areas of the exemplary first compression article of **FIG. 61A**, in accordance with some embodiments. **FIG. 62C** shows a side view of the adjustable tension areas of the exemplary first compression article of **FIG. 61A**, in accordance with some embodiments.

[0103] Shown in **FIGS. 62A-C** is the exemplary first compression article **6100** comprising a chest tensioner **6201**, an abdominal tensioner **6202**, a waist tensioner **6203**, a thigh tensioner **6204**, and an ankle tensioner **6205**. As seen, the exemplary first compression article **6100** may comprise one chest tensioner **6201**, one abdominal tensioner **6202**, one waist tensioner **6203**, two thigh tensioners **6204**, and two ankle tensioners **6205**. Alternatively, in some embodiments, the exemplary first compression article **6100** comprises 1, 2, 3, 4, 5, 6, 7, 8, 9, or 10 or more of each of the chest tensioner **6201**, the abdominal tensioner **6202**, the waist tensioner **6203**, the thigh tensioner **6204**, and the ankle tensioner **6205**.

[0104] In some embodiments, at least one of the chest tensioner **6201**, the abdominal

tensioner **6202**, the waist tensioner **6203**, the thigh tensioner **6204**, and the ankle tensioner **6205** are permanently attached to at least one of the neck support **6101**, the thigh support **6102**, the shin support **6103**, the spine support **6104**, the chest compression **6105**, the shoulder compression **6106**, the elbow compression **6107**, the thigh compression **6108**, the knee compression **6109**, the shin compression **6110**, the ankle compression **6111**, the waist compression **6112**, and the base layer **6120**. In some embodiments, at least one of the chest tensioner **6201**, the abdominal tensioner **6202**, the waist tensioner **6203**, the thigh tensioner **6204**, and the ankle tensioner **6205** are removably attached to at least one of the neck support **6101**, the thigh support **6102**, the shin support **6103**, the spine support **6104**, the chest compression **6105**, the shoulder compression **6106**, the elbow compression **6107**, the thigh compression **6108**, the knee compression **6109**, the shin compression **6110**, the ankle compression **6111**, the waist compression **6112**, and the base layer **6120**. In some embodiments, at least a portion of at least one of the chest tensioner **6201**, the abdominal tensioner **6202**, the waist tensioner **6203**, the thigh tensioner **6204**, and the ankle tensioner **6205** are attached to the first compression article **6100**.

[0105] In some embodiments, at least one of the chest tensioner **6201**, the abdominal tensioner **6202**, the waist tensioner **6203**, the thigh tensioner **6204**, and the ankle tensioner **6205** comprise a belt, a band, a strap, a hook and loop fastener, a clasp, a rope, a string, a hook, a cinch, or any combination thereof. In some embodiments, at least one of the chest tensioner **6201**, the abdominal tensioner **6202**, the waist tensioner **6203**, the thigh tensioner **6204**, and the ankle tensioner **6205** have one or more adjustable lengths or diameters configured to be adjusted by the subject to fit their body. In some embodiments, at least one of the chest tensioner **6201**, the abdominal tensioner **6202**, the waist tensioner **6203**, the thigh tensioner **6204**, and the ankle tensioner **6205** is elastic. In some embodiments, at least one of the chest tensioner **6201**, the abdominal tensioner **6202**, the waist tensioner **6203**, the thigh tensioner **6204**, and the ankle tensioner **6205** is rigid.

[0106] In some embodiments, at least one of the chest tensioner **6201**, the abdominal tensioner **6202**, the waist tensioner **6203**, the thigh tensioner **6204**, and the ankle tensioner **6205** are formed of fabric, thread, wood, fiberglass, carbon fiber, metal, a polymer, a gel, a foam, a composite, or any combination thereof. In some embodiments, at least one of the chest tensioner **6201**, the abdominal tensioner **6202**, the waist tensioner **6203**, the thigh tensioner **6204**, and the ankle tensioner **6205** are formed of the same material. In some embodiments, at least one of the chest tensioner **6201**, the abdominal tensioner **6202**, the waist tensioner **6203**, the thigh tensioner **6204**, and the ankle tensioner **6205** are formed of different materials.

[0107] In some embodiments, at least one of the chest tensioner **6201**, the abdominal tensioner **6202**, the waist tensioner **6203**, the thigh tensioner **6204**, and the ankle tensioner **6205** is configured to exert a continuous force, an adjustable, a proportional force, or a derivative force on the body of a subject. In some embodiments, at least one of the chest tensioner **6201**, the abdominal tensioner **6202**, the waist tensioner **6203**, the thigh tensioner **6204**, and the ankle tensioner **6205** is configured to exert a continuous force, a proportional

force, or a derivative force on the body of a subject throughout the subjects partial or full range of motion in at least one degree of freedom.

[0108] Provided herein per **FIGS. 63A-C** is an exemplary second compression article. **FIG. 63A** shows a front view of the exemplary second compression article, in accordance with some embodiments. **FIG. 63B** shows a side view of the exemplary second compression article, in accordance with some embodiments. **FIG. 63C** shows a back view of the exemplary second compression article, in accordance with some embodiments.

[0109] As shown in **FIGS. 63A-C**, the exemplary second compression article **6100** comprises a base layer **6120**, and at least one gripping element (not shown). In some embodiments, the at least one gripping element comprises 2, 3, 4, 5, 6, 7, 8, 9, or 10 or more gripping elements. In some embodiments, the gripping element comprises at least one of a shoulder gripping element, an arm gripping element, a forearm gripping element, a chest gripping element, a rib gripping element, a thigh gripping element, a shin gripping element, a knee gripping element, a collar gripping element, a buttocks gripping element, a hip gripping element, a neck gripping element, a wrist gripping element, and an ankle gripping element.

[0110] In some embodiments, the gripping element is configured to contact a body of the subject, wherein the gripping element has a second coefficient of friction (μ_2) relative to the body surface, wherein the second coefficient of friction (μ_2) is greater than the first coefficient of friction (μ_1). In some embodiments, the at least one gripping element is configured to exert at least one of a normal and a tangential force upon the body surface of the wearer. In some embodiments, the at least one gripping element is configured to exert at least one of a normal and a tangential force upon the body surface of the wearer to prevent substantial shifting of the article across the skin of the wearer. In some embodiments, the at least one gripping element comprises a surface texture configured to exert a tangential force upon the body surface of the wearer.

[0111] Gripping elements can provide traction to the interior surface of an article to prevent slipping or shifting when worn on the body of a subject. In some embodiments, gripping elements are made of a material having a coefficient of friction with skin that is relatively higher than the coefficient of friction of the base layer. Gripping elements provide an important function of maintaining optimal positioning of the support element (e.g. a neck support element or cervical/spinal support device) to protect and/or support the corresponding anatomy of the subject wearing the article. For example, an article that shifts substantially during the course of being worn by a subject may cause the neck support element protecting the neck to shift out of alignment and no longer be positioned snugly around the subject's neck. Thus, the neck support element may no longer provide the desired protection from injury such as in the case of a sudden impact or acceleration to the head of the subject. Accordingly, the gripping elements provide more than a comfortable fit, but actually are an important feature that improves the corresponding function of support element(s). This innovative combination of gripping and support elements helps produce a superior article for providing support and/or protection when worn by a subject.

[0112] Another aspect provided herein is a method for forming an article wearable by a subject, comprising: providing a base layer having an interior surface and an exterior surface, wherein the interior surface has a first coefficient of friction (μ_1) relative to a body surface of the subject, and wherein the base layer has a first modulus of elasticity (E_1); coupling at least one gripping element to the interior surface of the base layer, wherein the at least one gripping element is configured to contact a body of the subject, and wherein the at least one gripping element has a second coefficient of friction (μ_2) relative to the body surface, wherein μ_2 is greater than μ_1 ; coupling at least one compression element to the base layer, wherein the at least one compression element has a second modulus of elasticity (E_2) that is greater than E_1 ; and coupling at least one support element comprising a non-Newtonian material to the base layer.

[0113] In some embodiments, the method further comprises laminating or printing the compression element or gripping element adjacent to the base layer. In some embodiments, the printing is three-dimensional printing. In some embodiments, at least one of the support element, the compression element, and the gripping element is irremovably attached to the base layer. In some embodiments, at least one of the support element, the compression element, and the gripping element is removably attached to the base layer. In some embodiments, the at least one support element comprises a neck support. In some embodiments, the neck support comprises a penannular collar member that is anatomically complementary with a neck of the wearer. In some embodiments, the neck support comprises an elastomeric material or a force-reactive polymer positioned around a rear and lateral sides of a neck of the wearer. In some embodiments, the at least one support element comprises a spine support comprising at least one furrow configured to flex or fold along a set line, arch, or plane.

[0114] Another aspect provided herein is a method for mounting an article **6100** on a body of a subject, comprising: providing the article comprising a base layer **6200**, at least one gripping element **6300**, at least one compression element, and at least one support element; and mounting the article on a body of the subject. In some embodiments, the base layer **6200** has an interior surface and an exterior surface. In some embodiments, the interior surface has a first coefficient of friction (μ_1) relative to a body surface of the subject. In some embodiments, the base layer **6200** has a first modulus of elasticity (E_1). In some embodiments, the least one gripping element **6300** is coupled to the interior surface of the base layer **6200**. In some embodiments, the at least one gripping element **6300** is configured to contact a body of the subject. In some embodiments, the at least one gripping element **6300** has a second coefficient of friction (μ_2) relative to the body surface. In some embodiments, μ_2 is greater than μ_1 . In some embodiments, the at least one compression element coupled to the base layer **6200**. In some embodiments, the at least one compression element has a second modulus of elasticity (E_2) that is greater than E_1 . In some embodiments, the at least one support element comprises a non-Newtonian material. In some embodiments, the at least one support element is coupled to the base layer **6200**. In some embodiments, the interior surface and the at least one gripping element **6300** contact the body surface of the subject.

[0115] In some embodiments, when mounted on the body of the subject, the at least one gripping element **6300** contacts the body surface of the subject such that the article slides by at most 5 centimeters, 4 centimeters, 3 centimeters, 2 centimeters, or 1 centimeter. In some embodiments, when mounted on the body of the subject, the at least one gripping element **6300** contacts the body surface of the subject such that the article slides by at most 20 °, 15 °, 10 °, 5 °, or 1° about a point on the body of the subject. In some embodiments, when mounted on the body of the subject, the at least one gripping element **6300** contacts the body surface of the subject such that the article slides in a first direction by at most about 25 %, 20 %, 15 %, 10 %, 5 %, or 1% of the length of the gripping element **6300** in the first direction.

[0116] In some embodiments, when mounted on the body of the subject, the at least one support element provide stress relief, load transfer, fatigue relief, or any combination thereof to the subject. In some embodiments, when mounted on the body of the subject, the non-Newtonian material of the at least one support element comprises: a first viscosity (v_1) allowing unrestricted motion by the subject when the motion exerts a first force (F_1) upon the at least one support element; and a second viscosity (v_2) restricting motion by the subject when the motion exerts a second force (F_2) upon the at least one support element, wherein F_2 is greater than F_1 and v_2 is greater than v_1 . In some embodiments, when mounted on the body of the subject, the at least one support element provides resistance to movement of at least one of a muscle, a joint, or a bone of the subject, wherein the resistance increases with increasing force of the movement. In some embodiments, when mounted on the body of the subject, the at least one support element exerts a force on at least one of a muscle, a joint, or a bone of the subject throughout a full or partial range of motion in one or more degrees of freedom. In some embodiments, when mounted on the body of the subject, the at least one compression element provides stress support, load transfer, fatigue relief, or any combination thereof to the subject. In some embodiments, when mounted on the body of the subject, the at least one compression element is configured to exert a force on a muscle, bone, or joint of a wearer throughout a full or partial range of motion of the muscle, bone, or joint.

[0117] Shown in FIGS. **64A-E** is an exemplary third compression article. FIG. **64A** shows a front view of an exemplary long-sleeved third compression article, in accordance with some embodiments. FIG. **64B** shows a front view of an exemplary no-sleeve third compression article, in accordance with some embodiments. FIG. **64C** shows a detailed front view of the exemplary third compression article of FIG. **64A**, in accordance with some embodiments. FIG. **64D** shows a back view of the exemplary third compression article of FIG. **64A**, in accordance with some embodiments. FIG. **64E** shows a cross-sectioned side view of the exemplary second compression article of FIG. **64A**, in accordance with some embodiments.

[0118] Per FIGS. **64A-C** the exemplary third compression article **6400** comprises a base layer **6420**, at least one gripping element **6410**, and a neck support **6430**. In some embodiments, the at least one gripping element **6410** comprises 2, 3, 4, 5, 6, 7, 8, 9, or 10 or more gripping elements **6410**. In some embodiments, the gripping element **6410** comprises at least one of a shoulder gripping element, an arm gripping element, a forearm gripping element, a chest gripping element, a rib gripping element, a thigh gripping element, a shin gripping element, a

knee gripping element, a collar gripping element, a buttocks gripping element, a hip gripping element, a neck gripping element, a wrist gripping element, and an ankle gripping element.

[0119] In some embodiments, the gripping element **6410** is configured to contact a body of the subject, wherein the gripping element has a second coefficient of friction (μ_2) relative to the body surface, wherein the second coefficient of friction (μ_2) is greater than the first coefficient of friction (μ_1). In some embodiments, the at least one gripping element **6410** is configured to exert at least one of a normal and a tangential force upon the body surface of the wearer. In some embodiments, the at least one gripping element **6410** is configured to exert at least one of a normal and a tangential force upon the body surface of the wearer to prevent substantial shifting of the article across the skin of the wearer. In some embodiments, the at least one gripping element **6410** comprises a surface texture configured to exert a tangential force upon the body surface of the wearer.

[0120] As shown in **FIG. 64A**, the exemplary second compression article **6400** may comprise a long-sleeve second compression article **6400**. In some embodiments, the long-sleeve second compression article **6400** is configured for use in winter sports and/or full body contact sports. Alternatively, per **FIG. 64A**, the exemplary second compression article **6400** may comprise a short-sleeve second compression article **6400**. In some embodiments, the short-sleeve second compression article **6400** is configured for use in summer sports and/or reduced-contact sports.

[0121] As seen in **FIGS. 64A-E**, the neck support **6430** is configured to support the neck of a subject. In some embodiments, the neck support **6430** is configured to maintain continuous contact with the neck of a subject throughout the neck's full range of motion or partial range of motion. In some embodiments, the neck support **6430** is configured to exert a force on the neck of a subject throughout the neck's full range of motion or partial range of motion. In some embodiments, the neck support **6430** is configured to exert a continuous force, a proportional force, or a derivative force on the spine of a subject. In some embodiments, the force exerted by the neck support **6430** on the subject corresponds to at least one of the linear or angular position, velocity, and acceleration of the subject's neck. In some embodiments, the neck support **6430** comprises a cervical support device.

[0122] In some embodiments, the neck support **6430** is permanently attached to the base layer **6420**. In some embodiments, the neck support **6430** is laminated or printed adjacent to the base layer. In some embodiments, the neck support **6430** is removably attached to the base layer **6420**. In some embodiments, the neck support **6430** is removably attached to the interior surface of the base layer **6420**. In some embodiments, the neck support **6430** is attached to the exterior surface of the base layer **6420**.

[0123] In some embodiments, the neck support **6430** comprises one or more independent portions, wherein two or more of the independent portions are permanently or removably connected. In some embodiments, the two or more independent portions are rigidly or flexibly connected to each other. In some embodiments, the neck support **6430** has a thickness that is

uniform in at least one of a radial direction and a linear direction. In some embodiments, the neck support **6430** has a nonuniform thickness. In some embodiments, the neck support **6430** has lateral symmetry.

[0124] As seen in **FIG. 64C**, the neck support **6430** may comprise one or more furrows **6431**. In some embodiments, the one or more furrows **6431** are configured to flex or fold along a set line, arch, or plane. In some embodiments, the one or more furrows **6431** are configured to prevent or allow motion of the neck in one or more directions. In some embodiments, two or more of the furrows **6431** have equivalent sizes or shapes. In some embodiments, two or more of the furrows **6431** have inequivalent sizes or shapes. In some embodiments, at least one of the furrows **6431** lies generally parallel to a transverse plane of the subject. In some embodiments, at least one of the furrows **6431** extends radially about the neck of the subject. In some embodiments, at least one of the furrows **6431** extends radially and normally about the neck of the subject. In some embodiments, at least one of the furrows **6431** terminates at an edge of the neck support **6430**. In some embodiments, at least one of the furrows **6431** terminates without intersecting an edge of the neck support **6430**. As seen in **FIG. 61E**, the neck support **6430** comprises 4 furrows **6431**. Alternatively, in some embodiments, the neck support **6430** comprises 1, 2, 3, 4, 5, 6, 7, 8, 9, or 10 or more furrows **6431**.

[0125] As seen in **FIG. 64C**, the neck support **6430** may comprise one or more neck compression elements **6441 6442**. In some embodiments, the neck compression element **6441 6442** is permanently attached to the neck support **6430**, the base layer **6420**, or both. In some embodiments, the neck compression element **6441 6442** is removably attached to the neck support **6430**, the base layer **6420**, or both. In some embodiments, the neck compression element **6441 6442** is configured to adjust a baseline tension of the neck support **6430** on the user. Per **FIG. 64C**, the neck compression element **6441 6442** comprises two neck compression elements **6441 6442**. Alternatively, the neck compression element **6441 6442** comprises 3, 4, 5, 6, 7, 8, 9, or 10 or more neck compression elements **6441 6442**. Per **FIG. 64C**, the neck compression element **6441 6442** comprises fastener such as a hook and loop fastener. Alternatively, In some embodiments, the neck compression element **6441 6442** comprises strap a buckle, a zipper, a button, a hook, an eye, a lace, a magnet, a clasp, a clip, a screw, a bolt, a nut, a tie, or any combination thereof

[0126] In some embodiments, per **FIG. 64E**, the neck support **6430** comprises a neck support body **6433** surrounding a non-Newtonian foam **6434**, and a liner **6435** attached to neck support body **6433**. In some embodiments, the neck support body **6433** is formed of laminated Lycra. In some embodiments, the neck support body **6433** is permanently attached to the non-Newtonian foam **6434**, and the liner **6435**. In some embodiments, the neck support body **6433** is removably attached to the non-Newtonian foam **6434**, and the liner **6435**. In some embodiments, the liner **6435** comprises a mesh liner.

[0127] Devices, articles, systems and methods of the present disclosure may be combined with or modified by other devices, systems or methods, such as those disclosed in, for example, PCT/CA2016/051296.

Terms and Definitions

[0128] Unless otherwise defined, all technical terms used herein have the same meaning as commonly understood by one of ordinary skill in the art to which this invention belongs. As used in this specification and the appended claims, the singular forms "a," "an," and "the" include plural references unless the context clearly dictates otherwise. Any reference to "or" herein is intended to encompass "and/or" unless otherwise stated. As used in this specification and the claims, unless otherwise stated, the term "about," and "approximately" refers to variations of less than or equal to +/- 1%, +/- 2%, +/- 3%, +/- 4%, +/- 5%, +/- 6%, +/- 7%, +/- 8%, +/- 9%, +/- 10%, +/- 11%, +/-12%, +/- 14%, +/- 15%, or +/- 20% depending on the embodiment.

[0129] As used herein, the term "rate-sensitive material" refers to a material whose resistance to applied forces is dependent on the rate at which the force is applied, and more particularly to materials whose resistance to applied force increases the faster the force is applied. The term "rate-sensitive material" includes materials described as "rate dependent", "non-Newtonian" and/or having "non-linear properties" such as, for example, viscoelastic foam.

[0130] As used herein, the term "anatomically complementary" refers to a structure or shape adapted to receive the body region, or be received on the body region, with which it is to be used so as to engage and support the body region.

[0131] As used herein, the term "friction" refers to a force resisting the relative motion of materials or surfaces sliding against each other. Friction can refer to any of dry friction, fluid friction, lubricated friction, skin friction, and internal friction.

[0132] As used herein, the term "coefficient of friction" refers to a dimensionless scalar value describing the ratio between the frictional force between two materials or surfaces and the force pressing them together. For example, a low coefficient of friction indicates a low amount of friction between two surfaces relative to the force pressing them together (e.g. ice on a linoleum surface). Coefficient of friction can refer to static friction or kinetic friction. Different materials can be compared based on their respective coefficient of friction values relative to a common surface or material. For example, a polyester material and a silicone material can be compared based on their coefficient of friction against the skin of a subject.

[0133] As used herein, the term "close topographical engagement" refers to a shaping of the parts, and does not require direct physical contact between the wearable article and the body region, but rather that there be sufficient engagement to permit effective transmission of forces from the body region to the wearable article.

[0134] As used herein, the term "anatomically non-restrictive" as used herein, means that the wearable article, when secured in close topographical engagement on the relevant body

region, permits that body region to move through substantially normal ranges of motion.

[0135] As used herein, the terms "inferior" and "superior" are used herein in their anatomical sense, and are synonymous with "cranial" (toward the skull) and caudal (toward the hips), respectively

[0136] While preferred embodiments of the present invention have been shown and described herein, it will be obvious to those skilled in the art that such embodiments are provided by way of example only. Numerous variations, changes, and substitutions will now occur to those skilled in the art without departing from the invention. It should be understood that various alternatives to the embodiments of the invention described herein may be employed in practicing the invention. While human spinal support devices have been described and illustrated as examples of wearable articles and articles constructed according to the principles of the present disclosure, it is to be understood these principles are not limited to spinal support devices, and that wearable articles and articles may be adapted to other body regions and/or other subjects. The scope of the invention is defined by the appended claims.

REFERENCES CITED IN THE DESCRIPTION

Cited references

This list of references cited by the applicant is for the reader's convenience only. It does not form part of the European patent document. Even though great care has been taken in compiling the references, errors or omissions cannot be excluded and the EPO disclaims all liability in this regard.

Patent documents cited in the description

- [US62502254 \[0001\]](#)
- [US62543854 \[0001\]](#)
- [US5328447A \[0003\]](#)
- [CA2016051296W \[0127\]](#)

PATENTKRAV

1. En artikel til støtte og beskyttelse, der kan bæres af et emne, omfattende:
 - a) et basislag (6120) med en indvendig overflade og en udvendig overflade, hvor
5 den indvendige overflade har en første friktionskoefficient (μ_1) i forhold til emnets kropsoverflade, og hvor basislaget (6120) har et første elasticitetsmodul (E1);
 - b) mindst et gribeelement (6300) koblet til basislagets (6120) indvendige overflade, hvor det mindst ene gribeelement (6300) er konfigureret til at kontakte med emnets krop, og hvor det mindst ene gribeelement (6300) har en anden
10 friktionskoefficient (μ_2) i forhold til kroppens overflade, hvor μ_2 er større end μ_1 ;
 - c) mindst et kompressionselement (6105) koblet til basislaget (6120), hvor det mindst ene kompressionselement (6105) har et andet elasticitetsmodul (E2), der er større end E1; og
 - d) mindst et støtteelement (6430) omfattende et ikke-newtonsk materiale koblet til
15 basislaget (6120).

2. Artikel ifølge krav 1, hvor det mindst ene gribeelement (6300) er en flerhed af gribeelementer positioneret på basislagets (6120) indvendige overflade på en måde, der begrænser eller reducerer basislagets (6120) glidende bevægelse på tværs af
20 kroppens overflade.

3. Artikel ifølge krav 2, hvor artiklen kan monteres på emnets overarm eller underarm, skulder, bryst, ryg, torso, balder, lår, eller underben eller læg, og hvor flerheden af gribeelementer begrænser eller reducerer den glidende bevægelse på tværs af emnets
25 overarm eller underarm, skulder, bryst, ryg, torso, balder, lår, eller underben eller læg.

4. Artikel ifølge krav 1, hvor det mindst ene støtteelement (6430) omfatter mindst en af:
 - a) et nakkestøtteelement;
 - b) et lårstøtteelement;
 - c) et skinnebensstøtteelement; eller
30
 - d) et rygsøjlestøtteelement.

5. Artikel ifølge krav 1, hvor et eller flere af det mindst ene støtteelement (6430), det mindst ene kompressionselement (6105) og det mindst ene gribeelement[[et]] (6300) er
35 lamineret eller printet tilstødende til basislaget (6120), og eventuelt hvor en eller flere af det mindst ene støtteelement (6430), det mindst ene kompressionselement (6105) og det mindst ene gribeelement (6300) er fastgjort aftageligt på basislagets (6120) indvendige overflade.

6. Artikel ifølge krav 1, hvor en eller flere af det mindst ene støtteelement (6430) og det mindst ene kompressionselement (6105) er fastgjort til basislagets (6120) udvendige overflade, eventuelt hvor en eller flere af det mindst ene støtteelement (6430), det mindst ene kompressionselement (6105) og det mindst ene gribeelement (6300) er fastgjort aftageligt til basislaget (6120) ved hjælp af en fastgørelse, og eventuelt hvor fastgørelsen omfatter en rem, et spænde, et krog- og løkkebeslag, en lynlås, en knap, en krog, et øje, en snøre, en magnet, en hægte, en klemme, en skrue, en bolt, en møtrik, et bånd eller enhver kombination deraf.
7. Artikel ifølge krav 1, hvor en eller flere af det mindst ene støtteelement (6430), det mindst ene kompressionselement (6105), det mindst ene gribeelement (6300) og basislaget (6120) har et elasticitetsmodul på omkring 0,01 GPa til omkring 15 GPa, eller hvor mindst et af støtteelementet (6430), kompressionselementet (6105), gribeelementet (6300) og basislaget (6120) er slidstærkt, vandtæt, pletafvisende, allergivenligt, antibakterielt, selvreparerende, varmebestandigt, friktionsbestandigt eller enhver kombination deraf.
8. Artikel ifølge krav 1, hvor en eller flere af det mindst ene gribeelement (6300), det mindst ene kompressionselement (6105) eller basislaget (6120) er formet af et polymermateriale eller sammensat materiale.
9. Artikel ifølge krav 1, hvor det mindst ene kompressionselement (6105) omfatter silikone, nylon, lycra, gummi, neopren, vinyl, polyuretan eller enhver kombination deraf.
10. Artikel ifølge krav 1, hvor det mindst ene støtteelement (6430) omfatter en elastomerisk polymer, eller hvor det mindst ene støtteelement (6430) omfatter en gel, en skum, en ikke-newtonsk væske eller enhver kombination deraf.
11. Artikel ifølge krav 1, hvor det mindst ene støtteelement (6430) omfatter en skum omfattende en forskydningsfortykkende ikke-newtonsk væske, og eventuelt hvor den ikke-newtonske væske er indkapslet i en pose.
12. Artikel ifølge krav 1, hvor det mindst ene støtteelement (6430) omfatter et newtonsk skummateriale positioneret imellem emnets kropsoverflade og det ikke-newtonske materiale.
13. Artikel ifølge krav 1, hvor det mindst ene støtteelement (6430) omfatter en halsstøtte omfattende et elastomermateriale eller en kraft-reaktiv polymer positioneret omkring

bagsiden og laterale sider på brugerens hals.

14. Artikel ifølge krav 1, derudover omfattende et ledningsnet sikret til mindst et støtteelement (6430), eventuelt hvor ledningsnettet er integreret i basislaget (6120), og eventuelt hvor ledningsnettet er lamineret eller printet tilstødende til basislaget (6120).
15. Artikel ifølge krav 1, hvor artiklen er en trøje, et par bukser eller en heldragt.

DRAWINGS

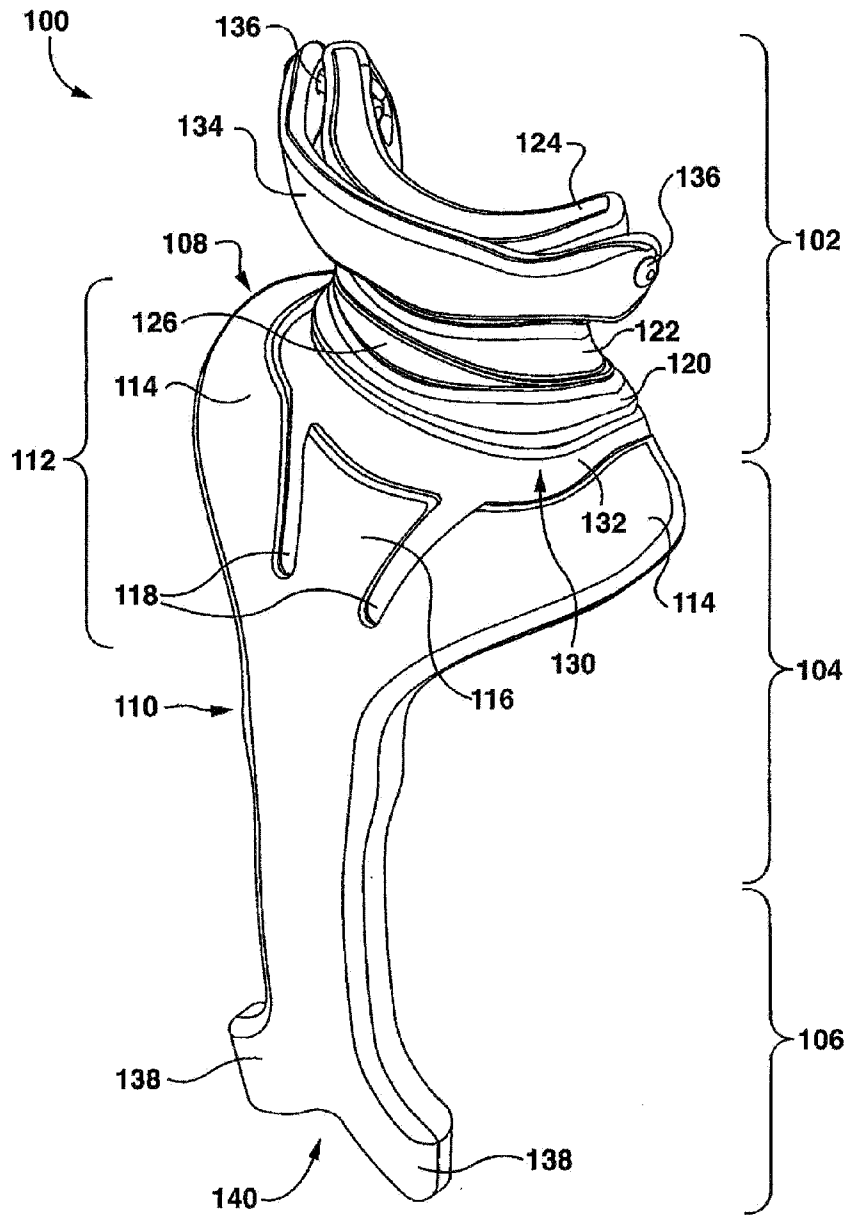

FIG. 1

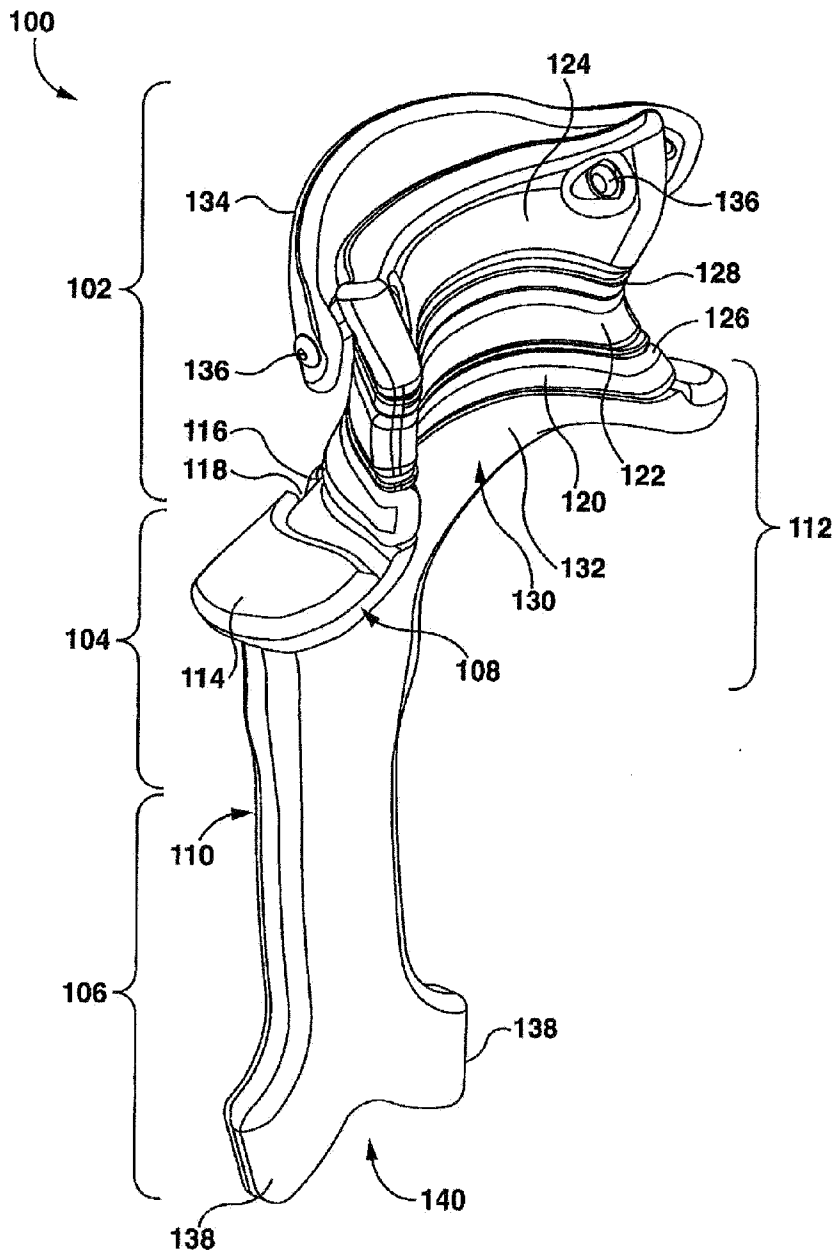

FIG. 2

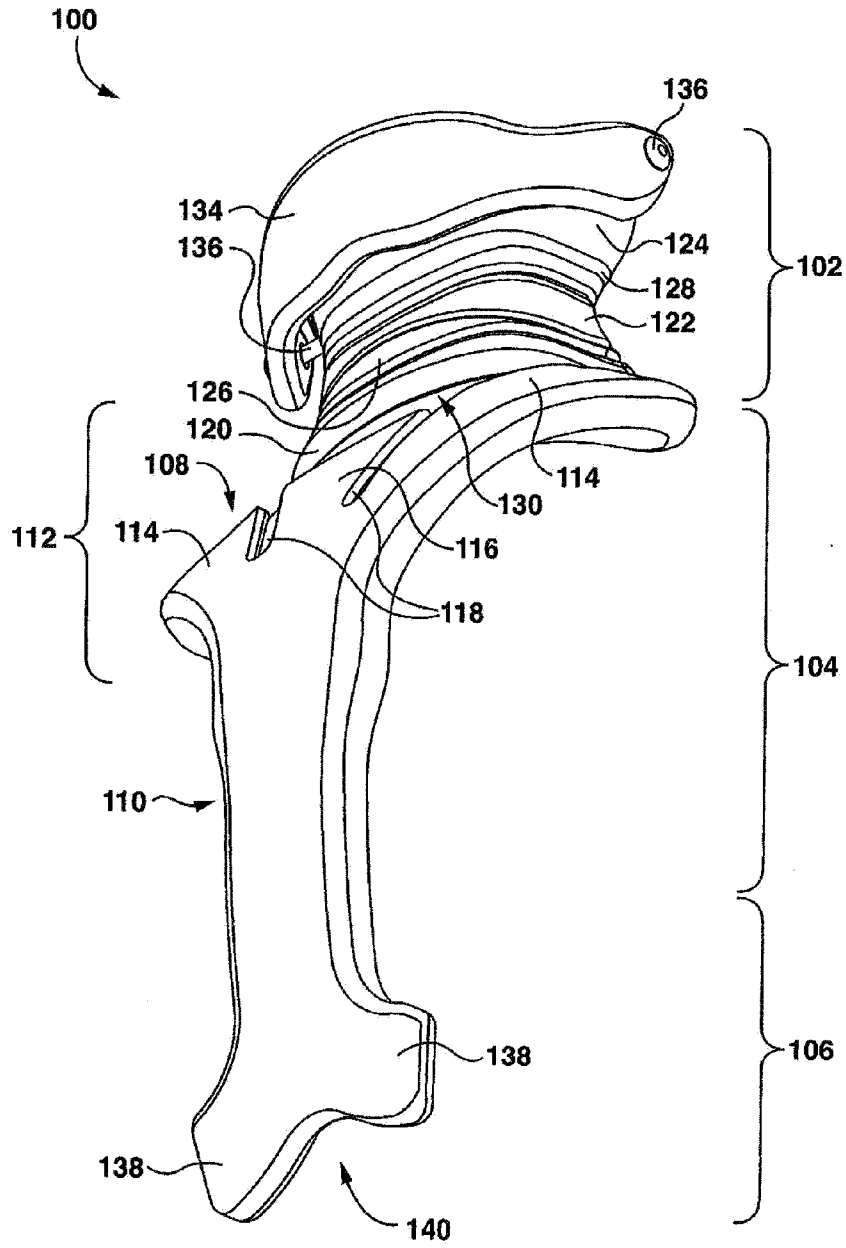

FIG. 3

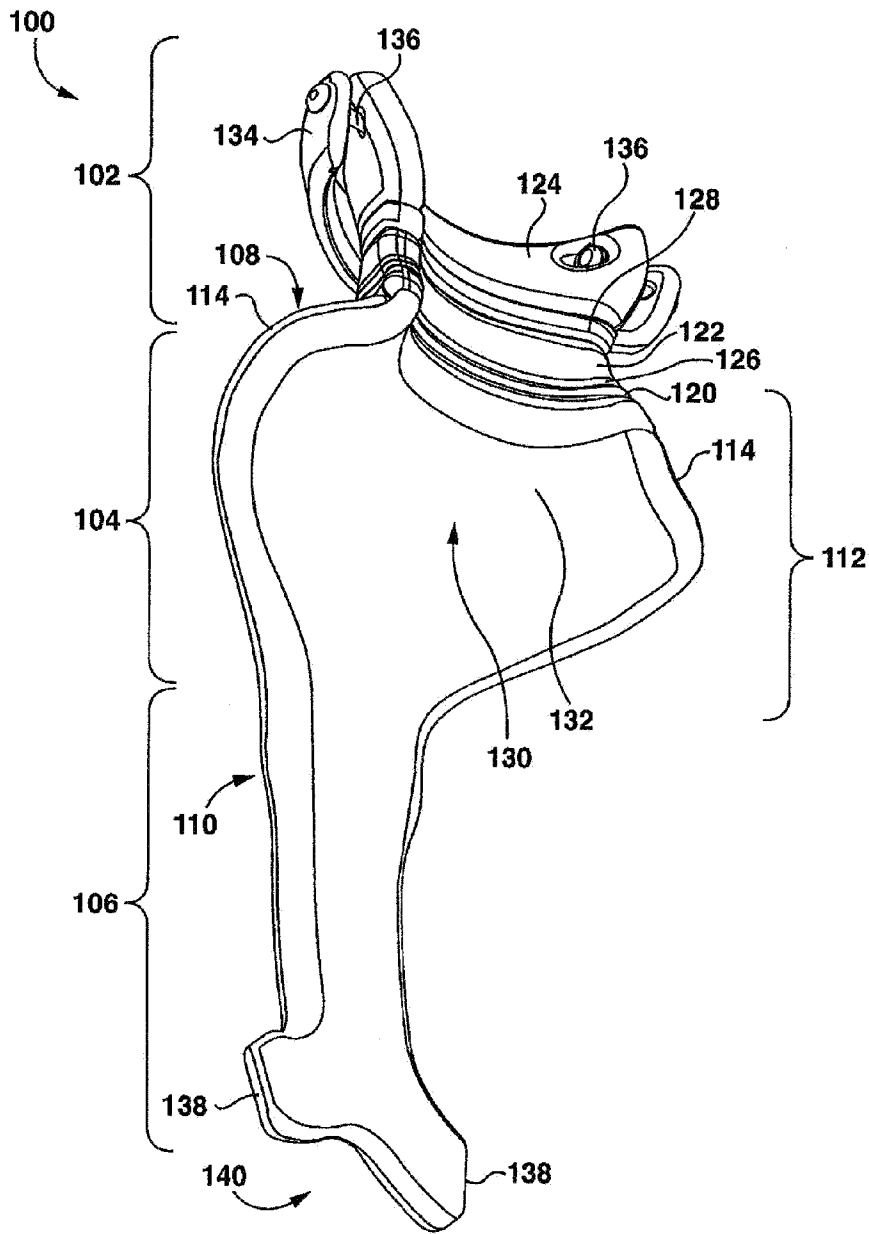
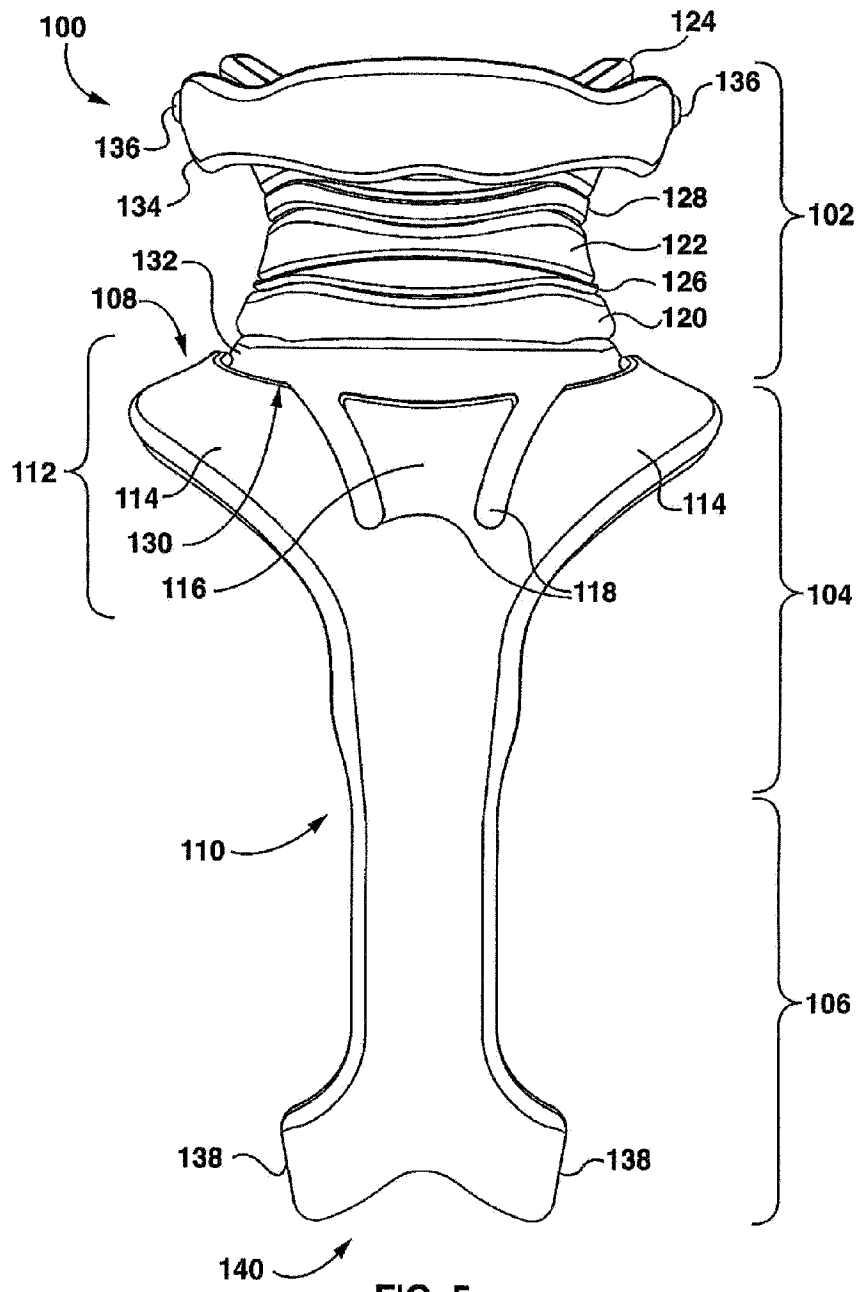
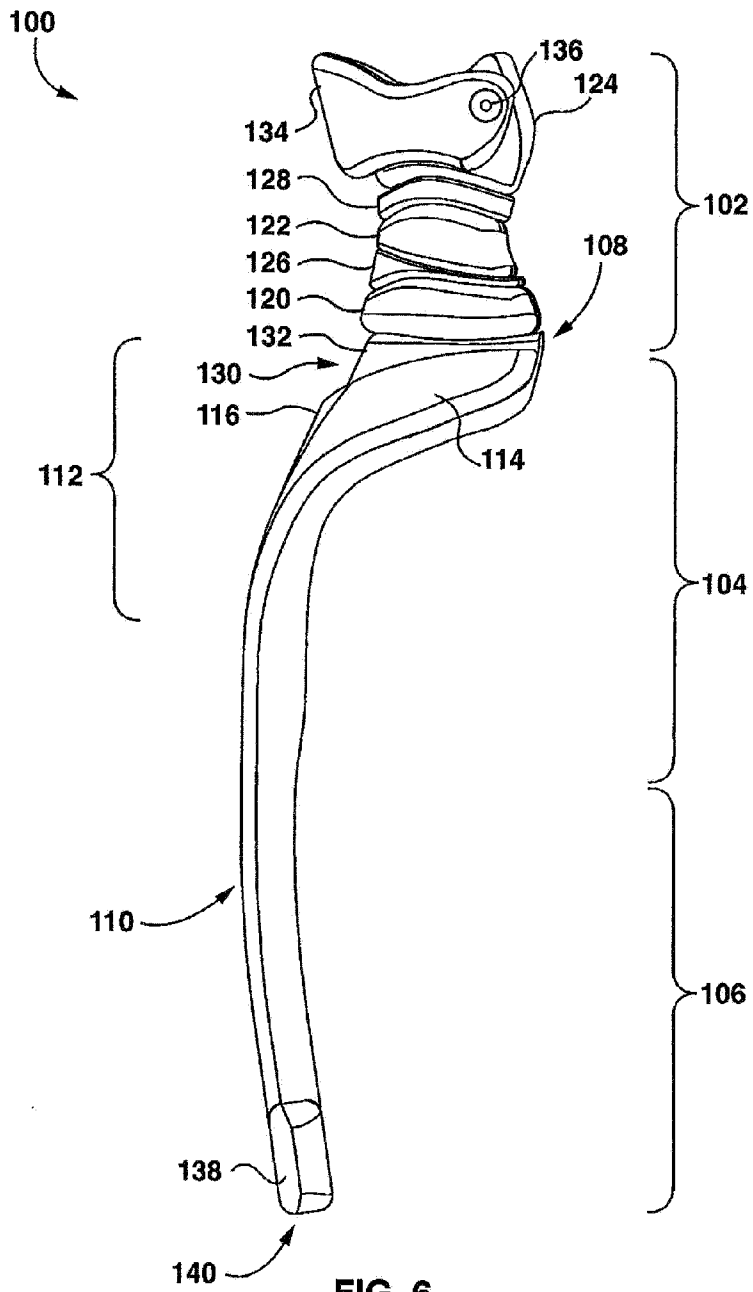

FIG. 4





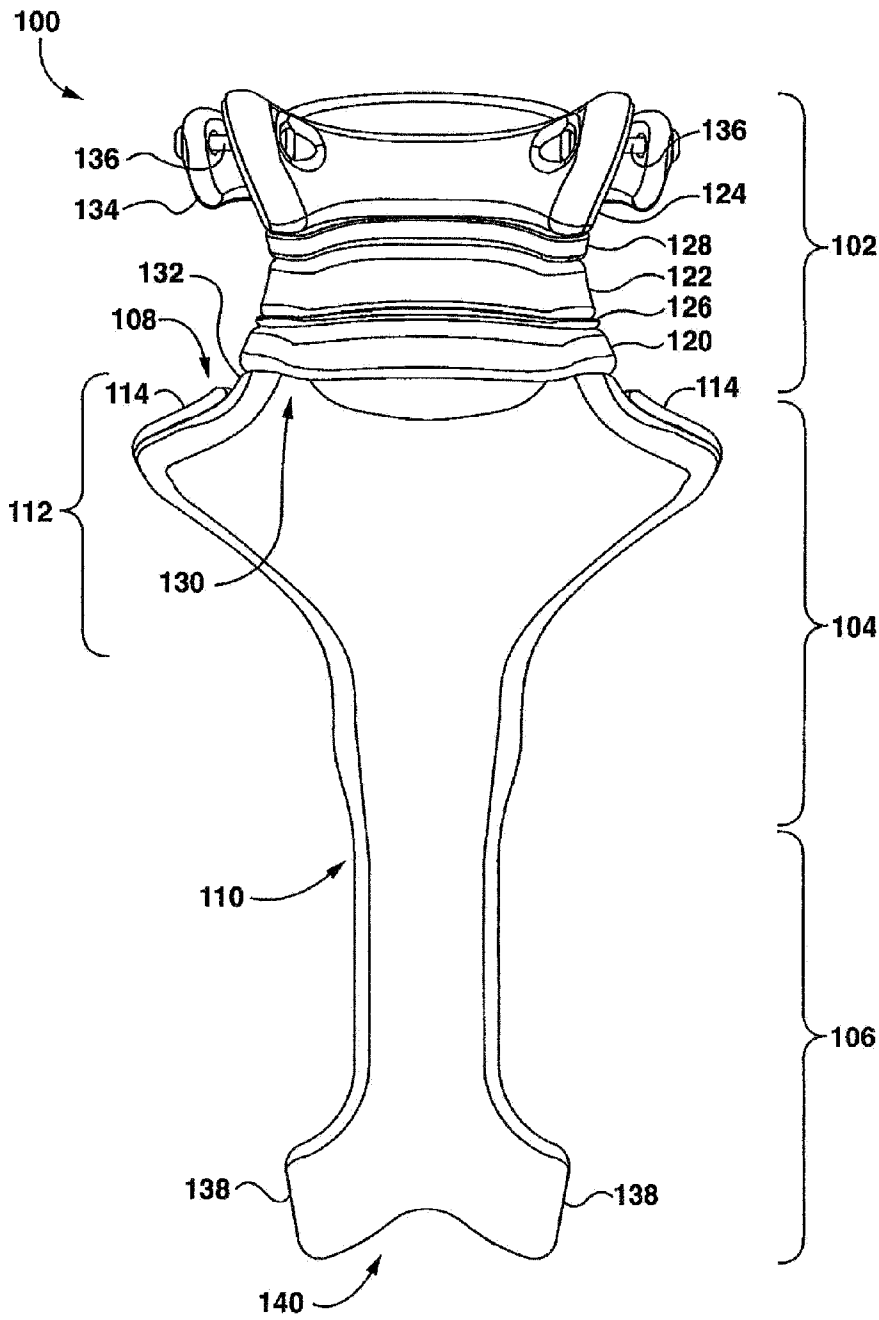

FIG. 7

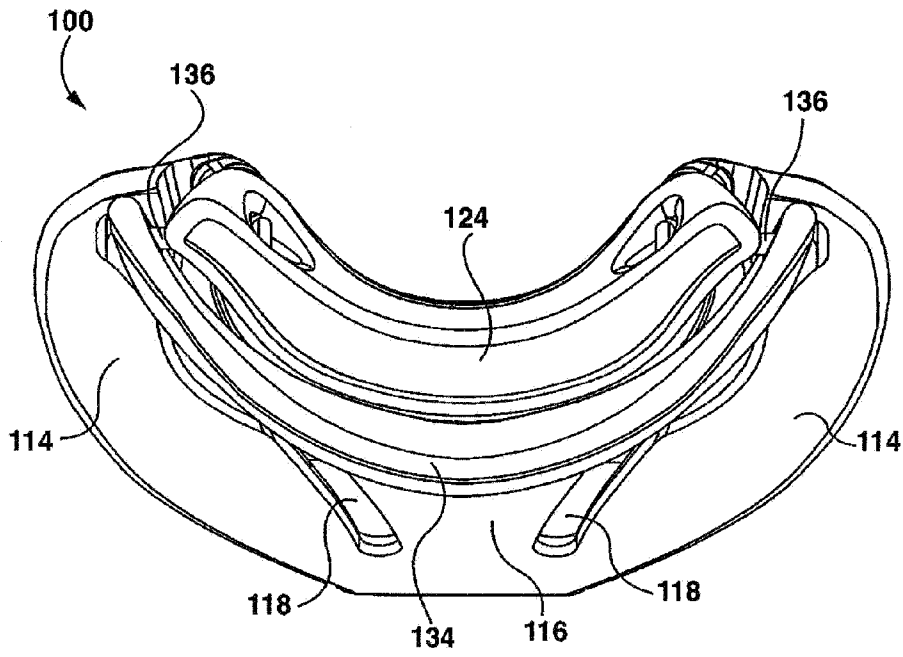

FIG. 8

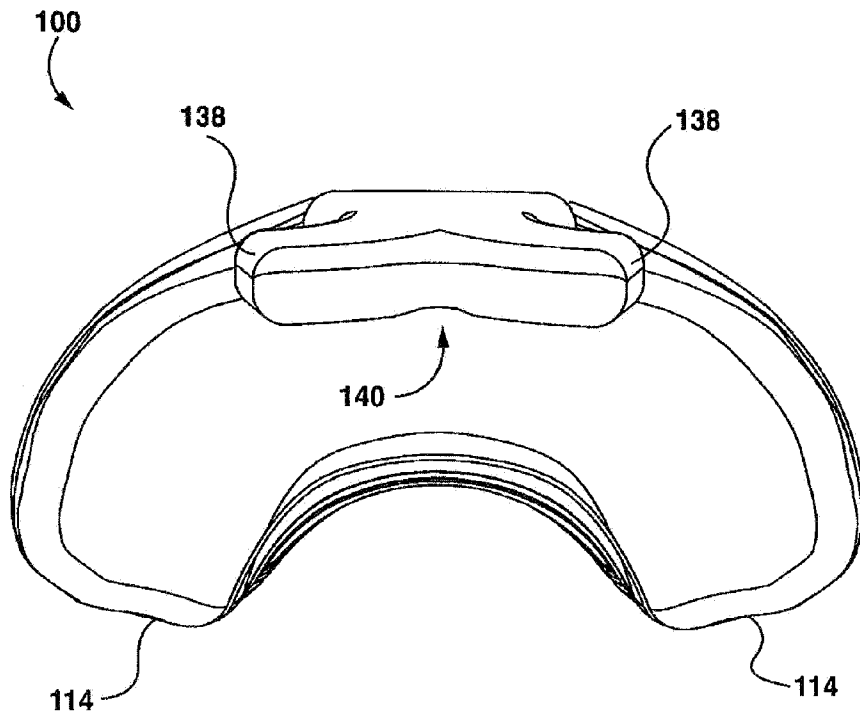

FIG. 9

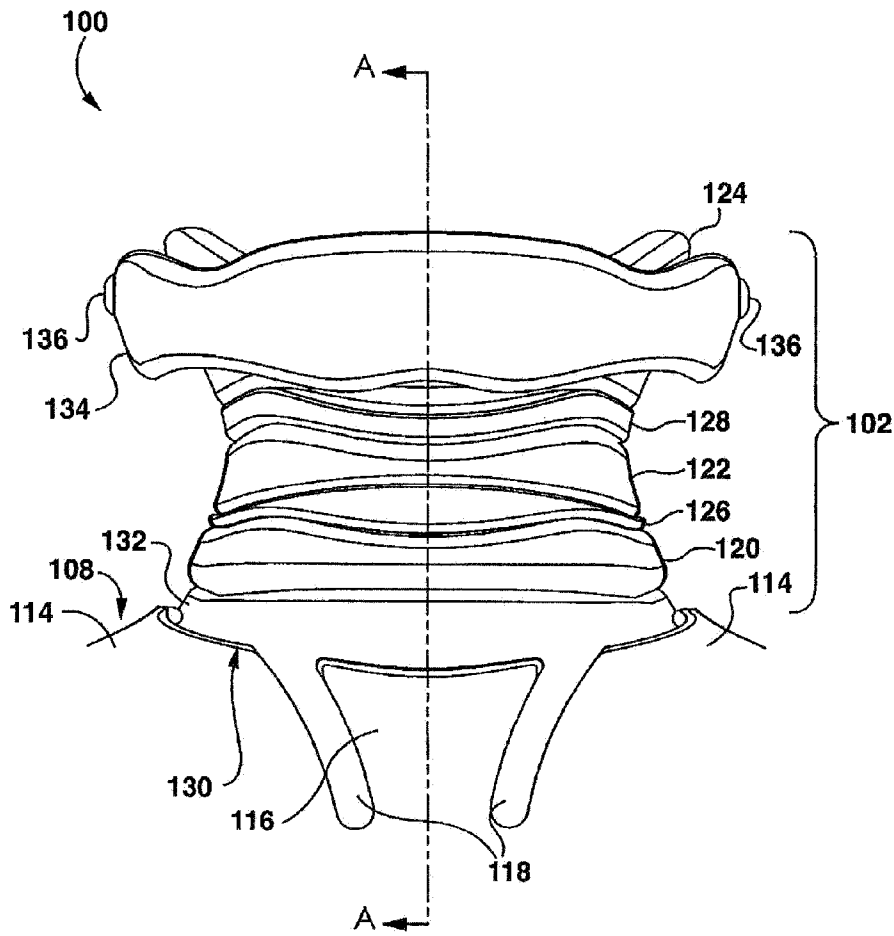

FIG. 10

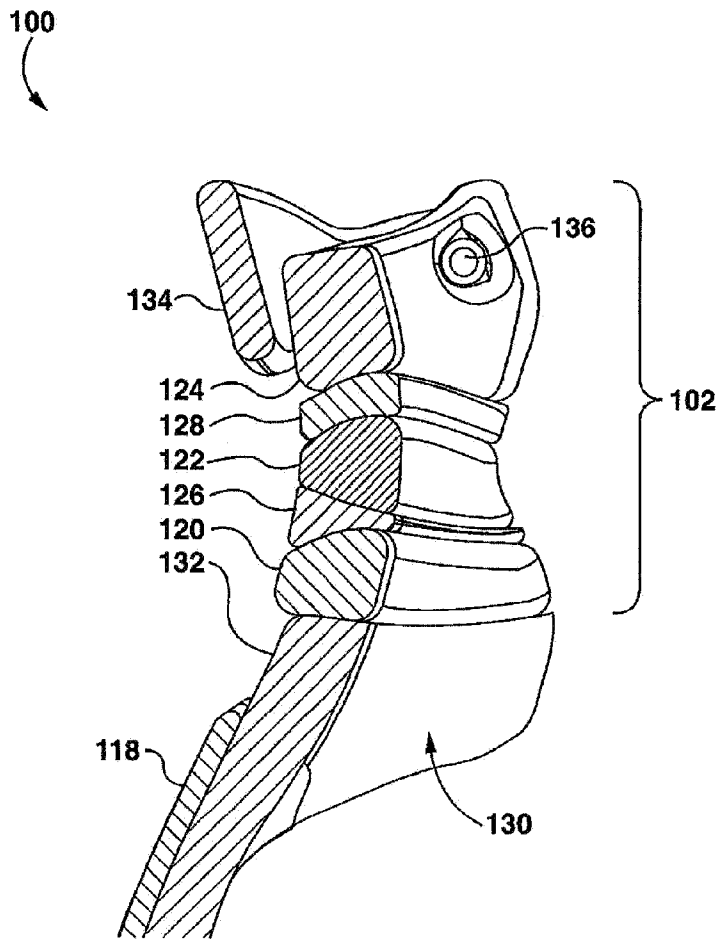

FIG. 11

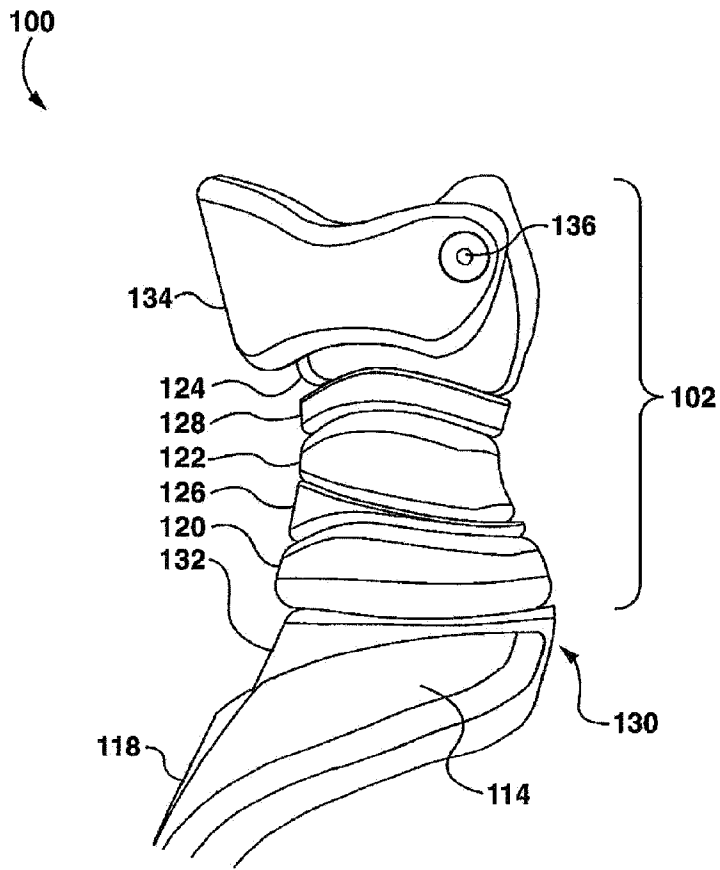

FIG. 12

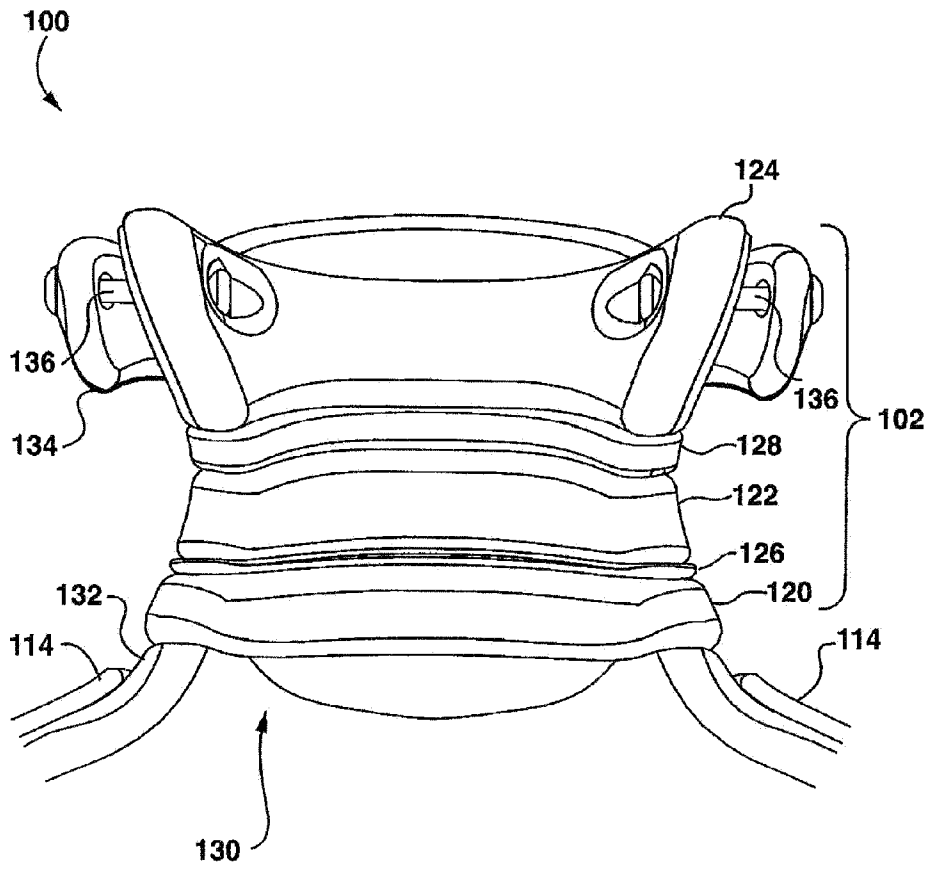

FIG. 13

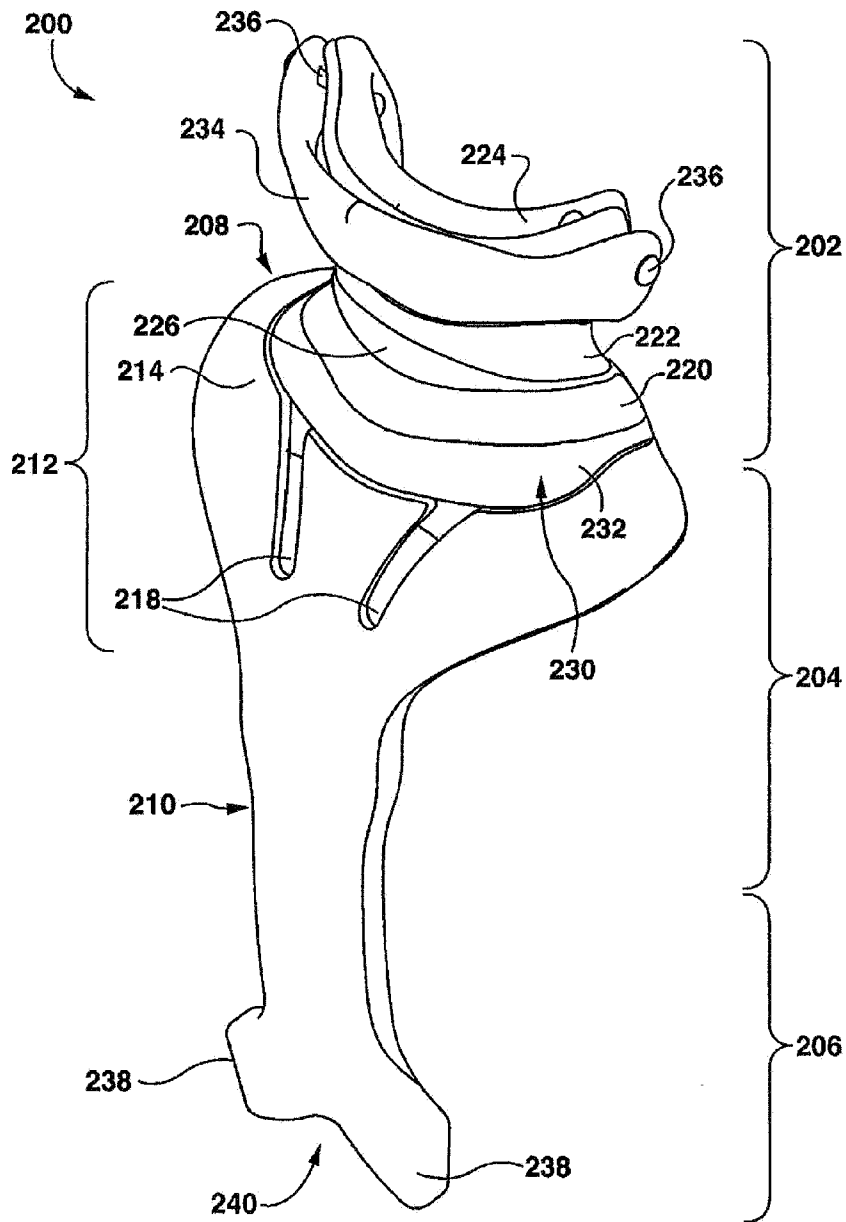
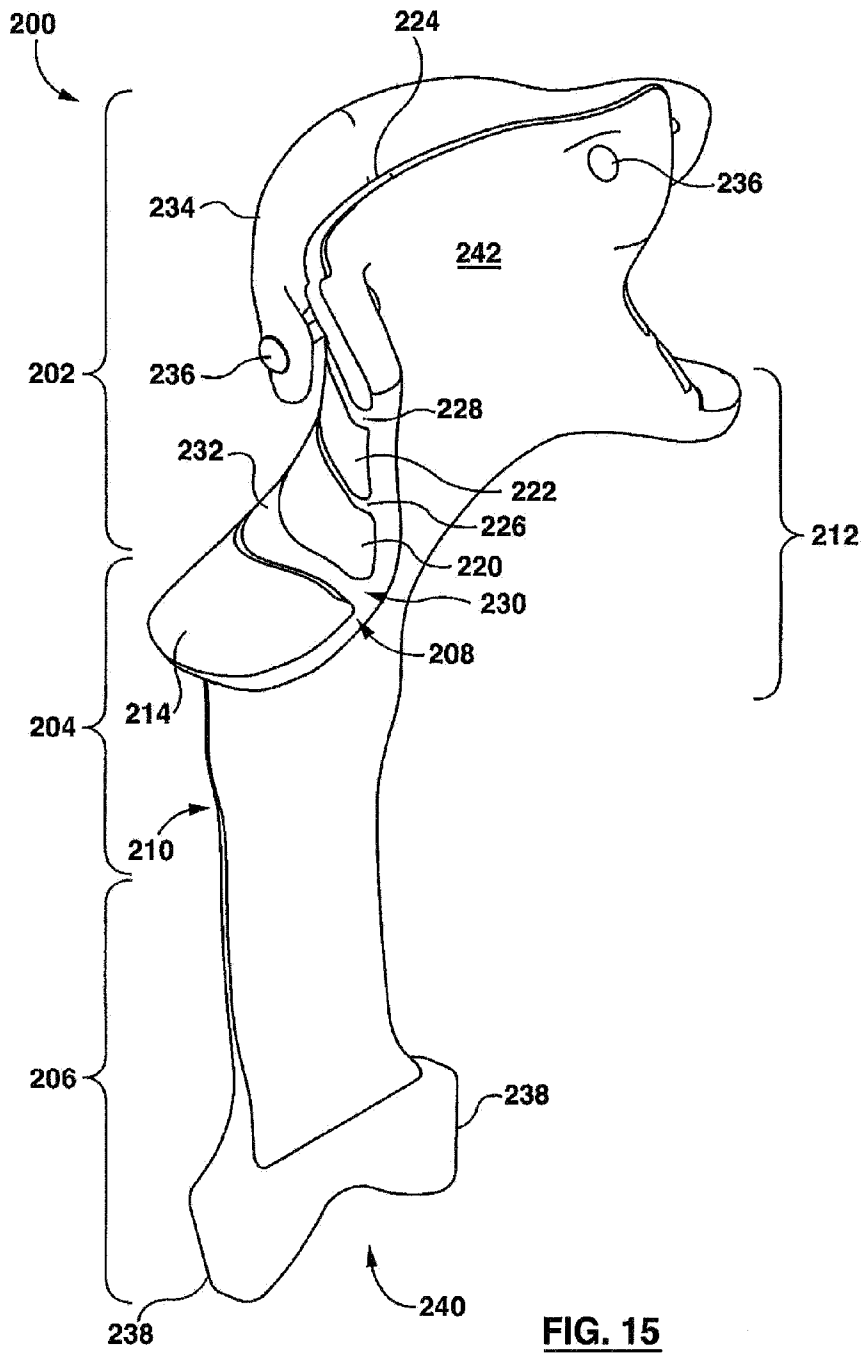

FIG. 14



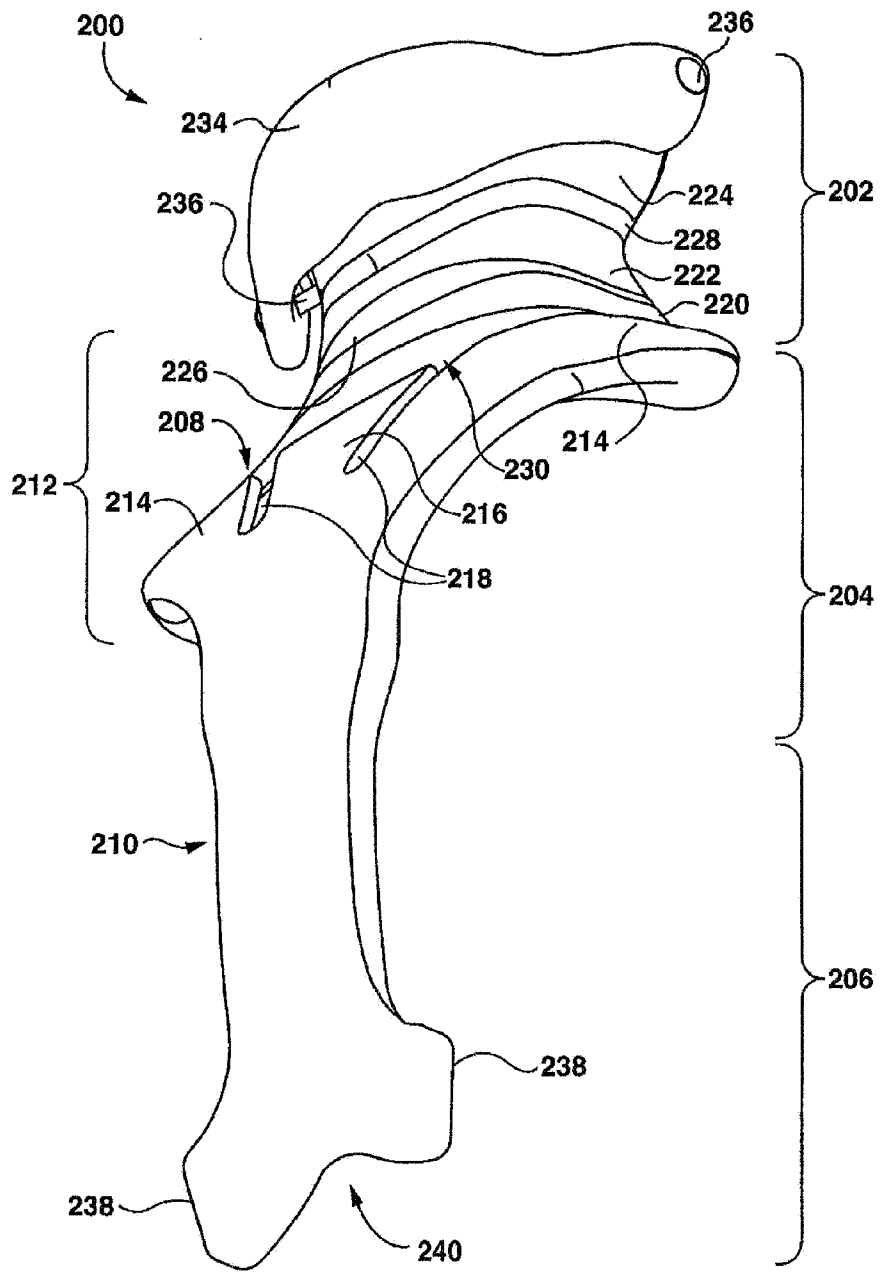

FIG. 16

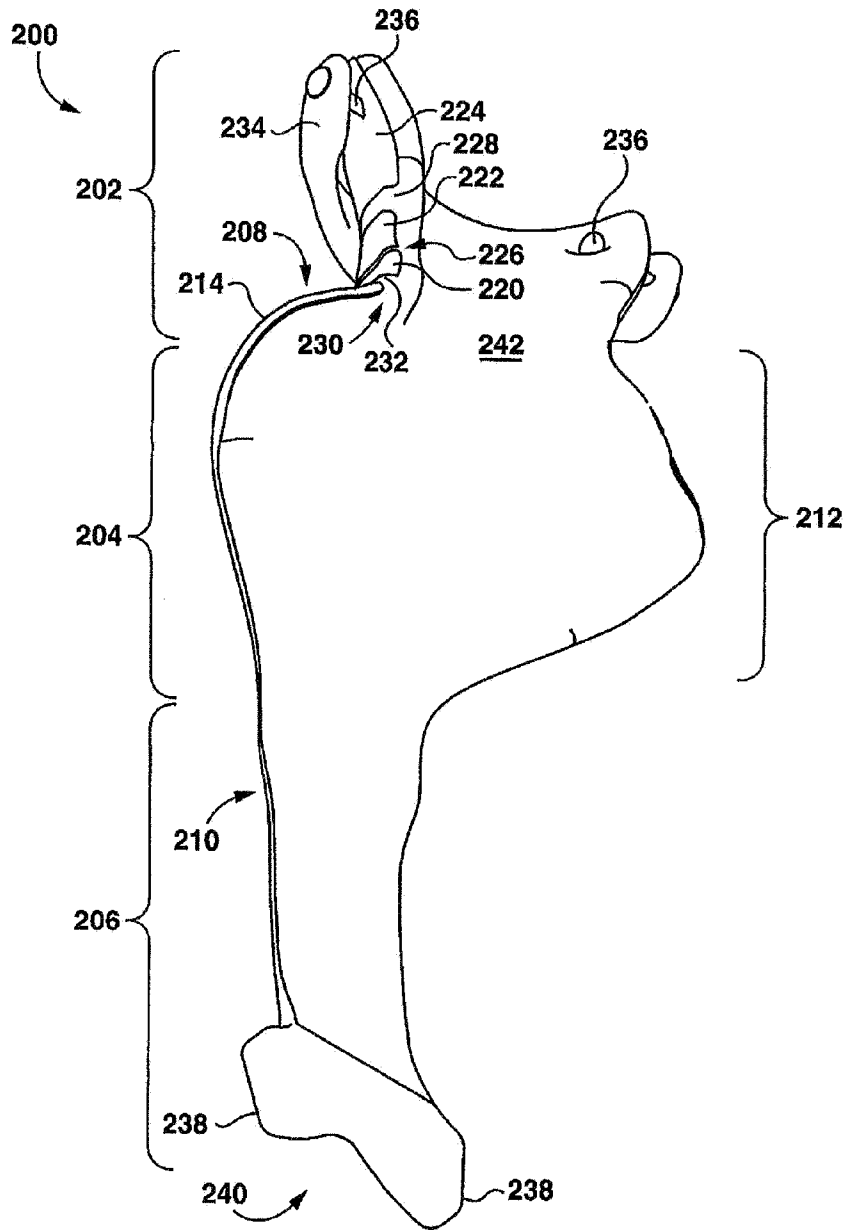

FIG. 17

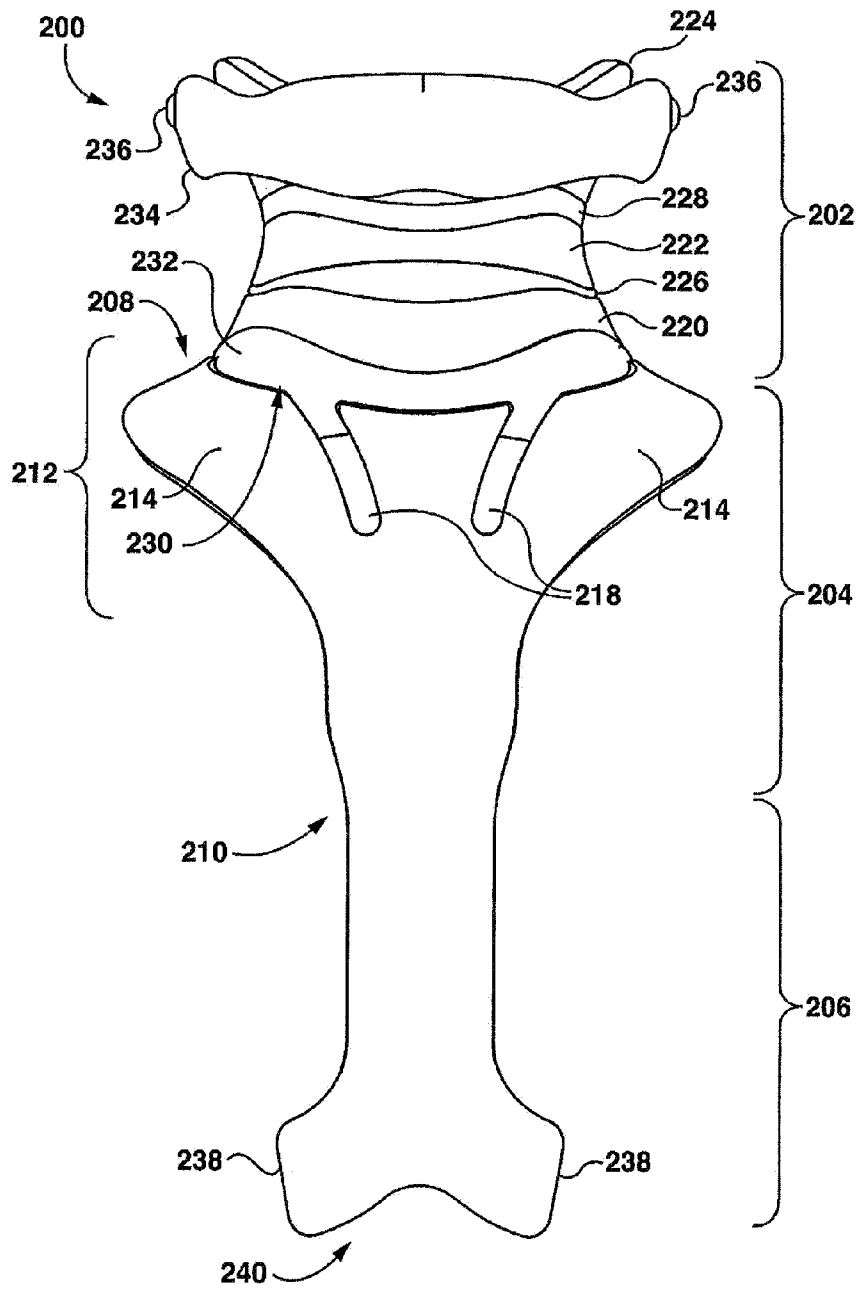

FIG. 18

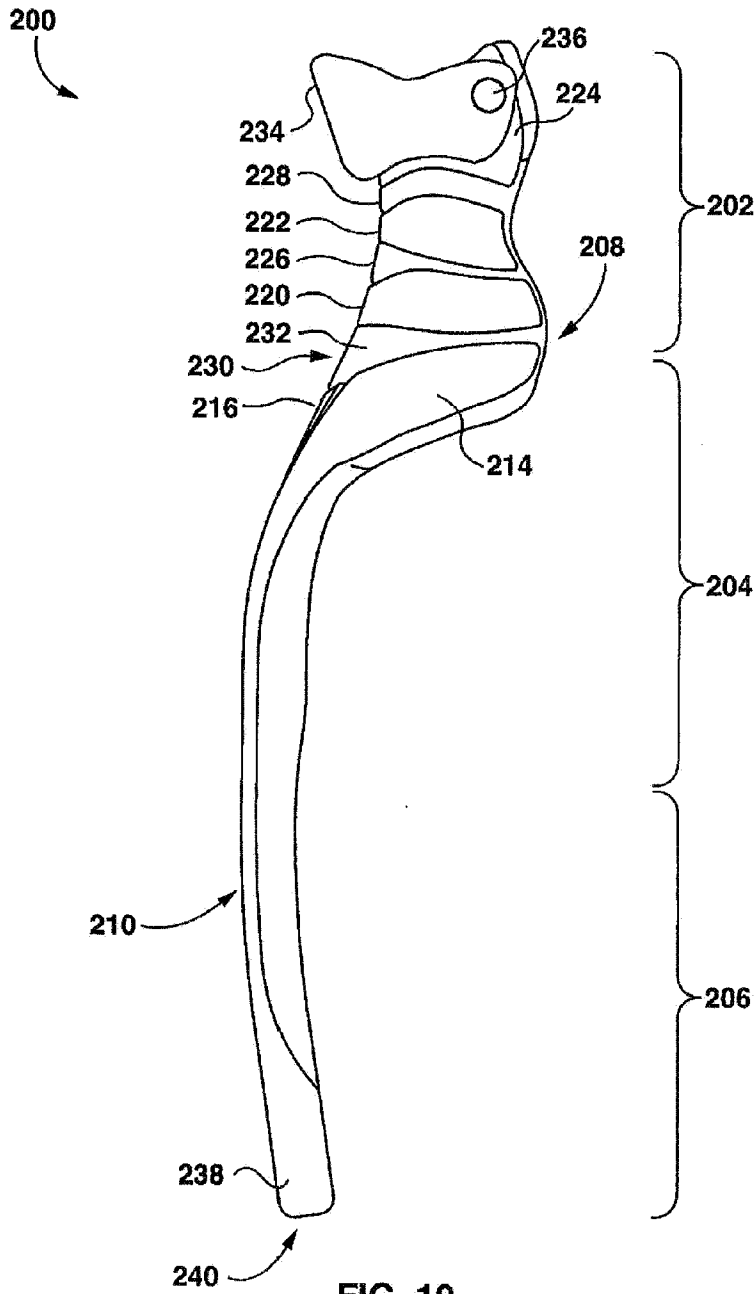

FIG. 19

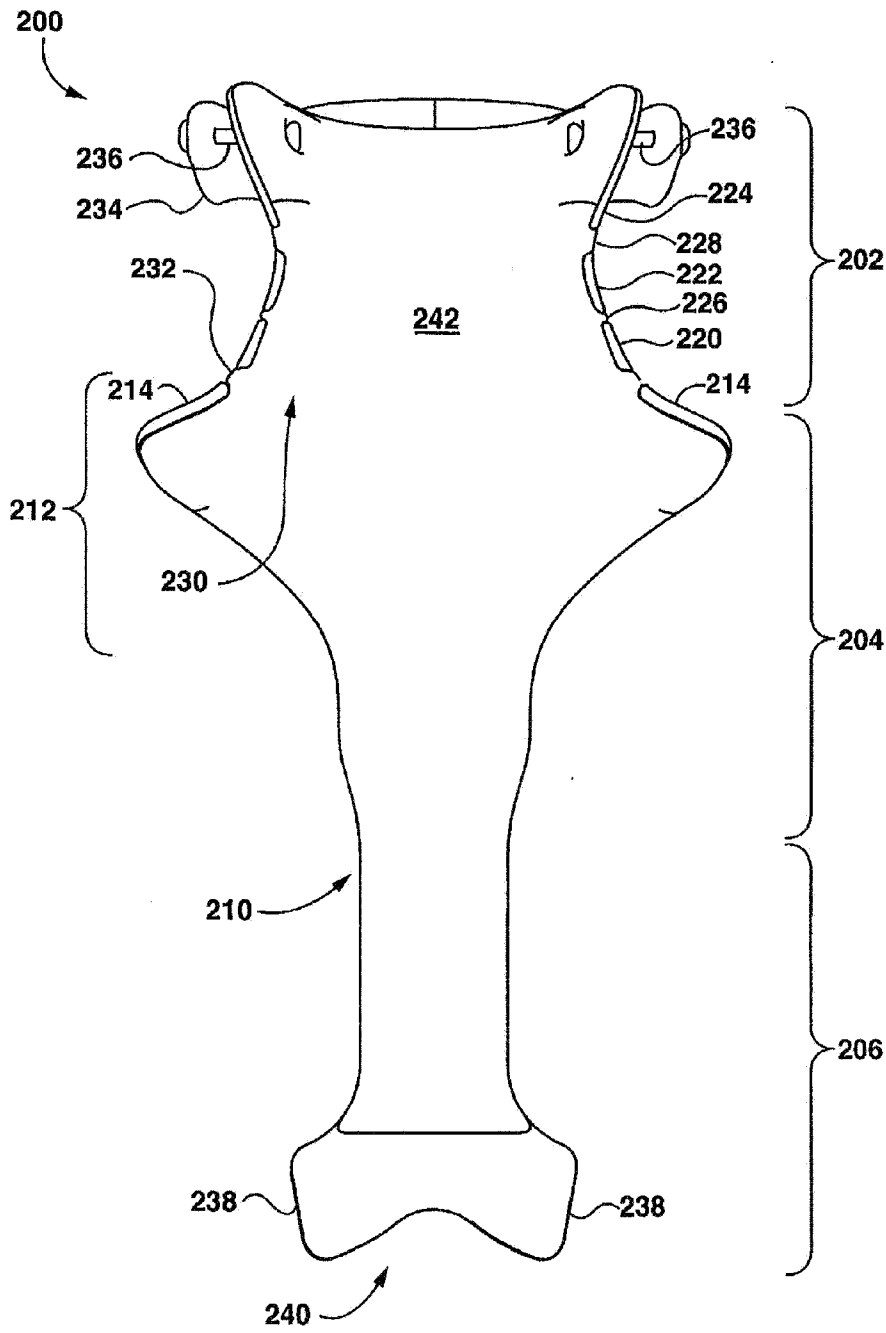

FIG. 20

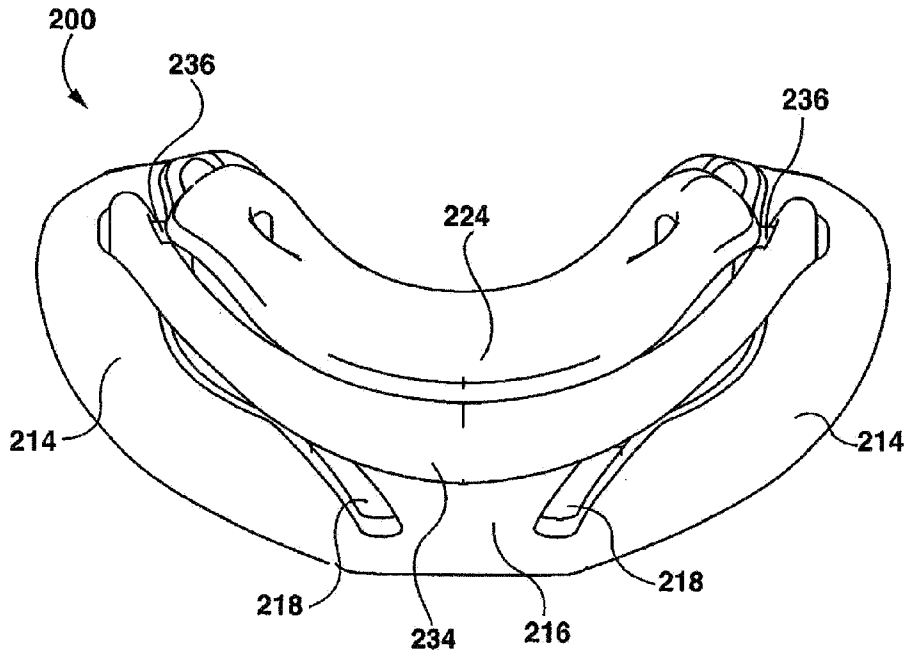

FIG. 21

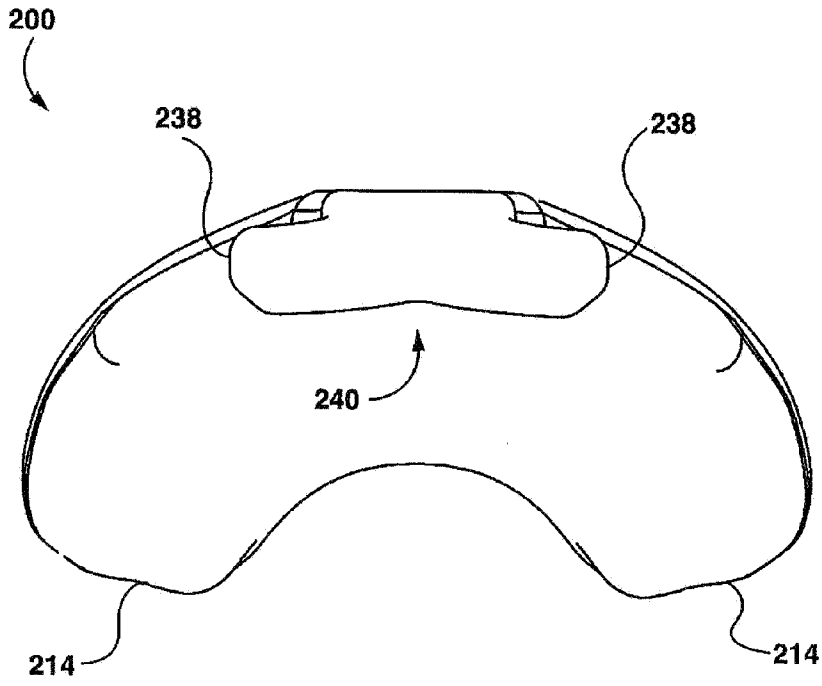

FIG. 22

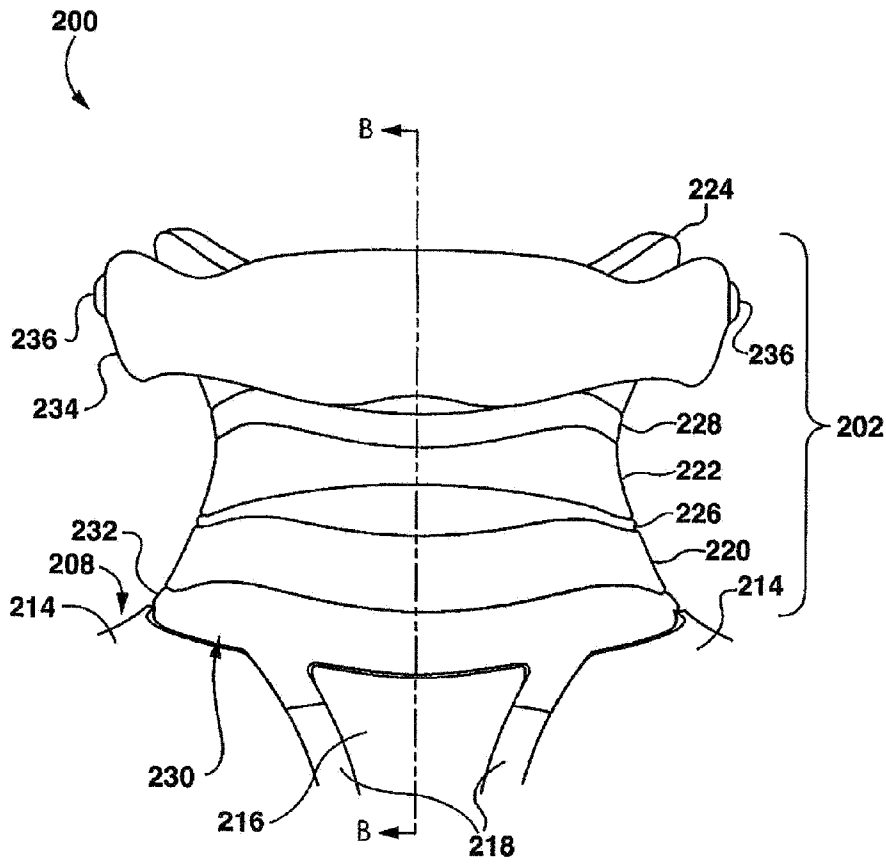

FIG. 23

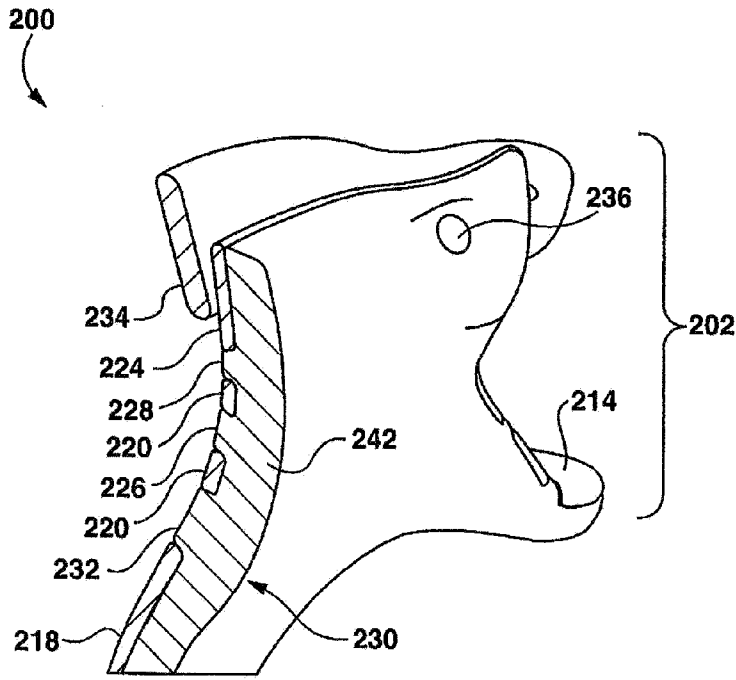

FIG. 24

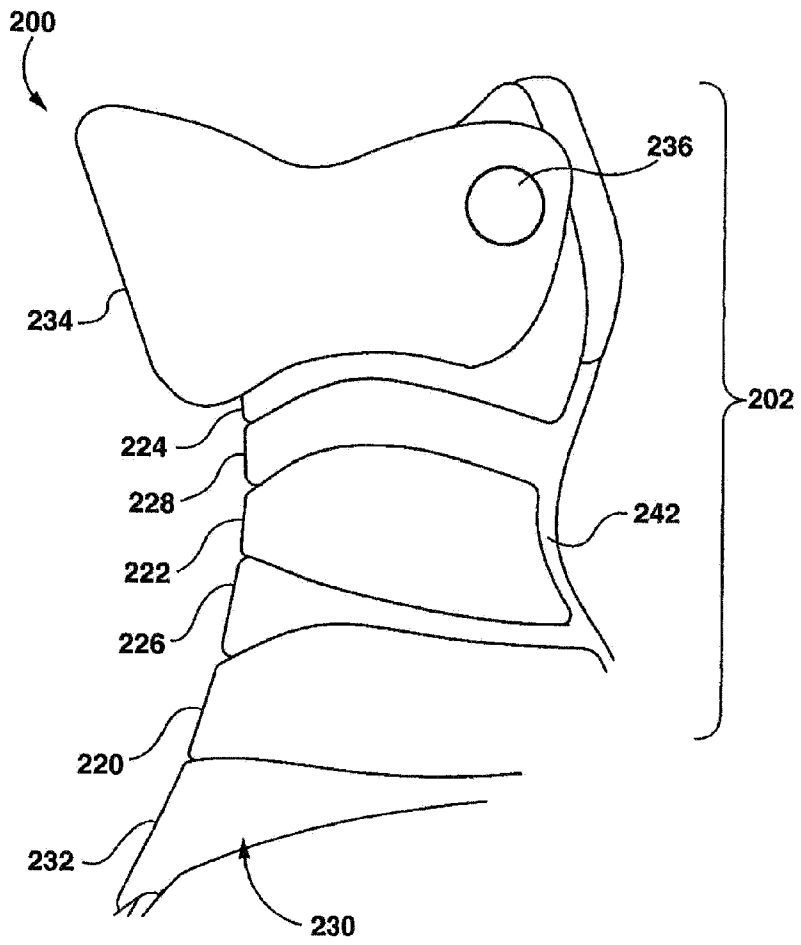

FIG. 25

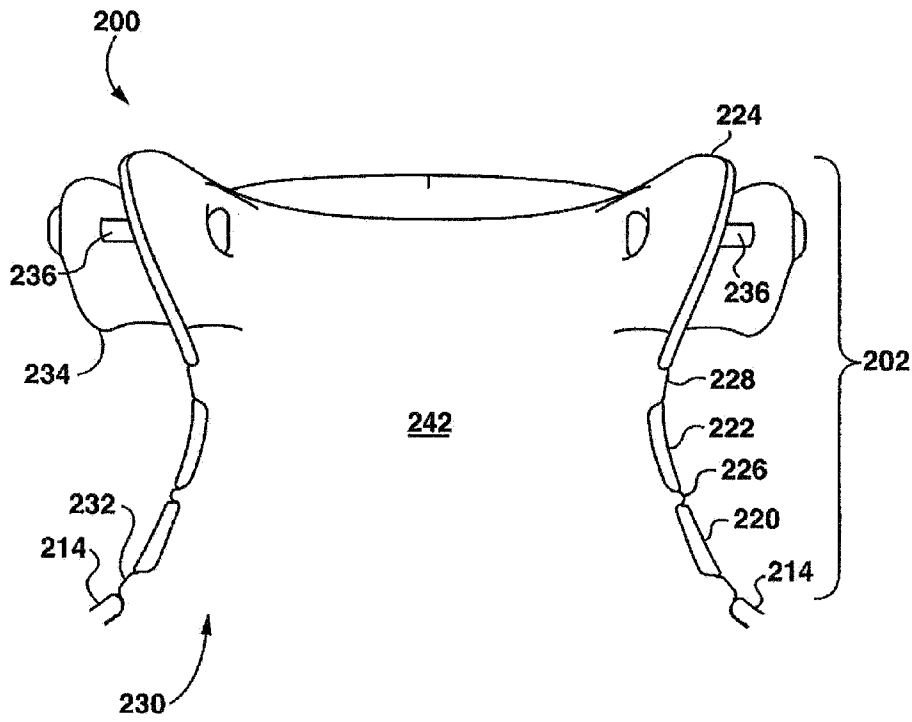

FIG. 26

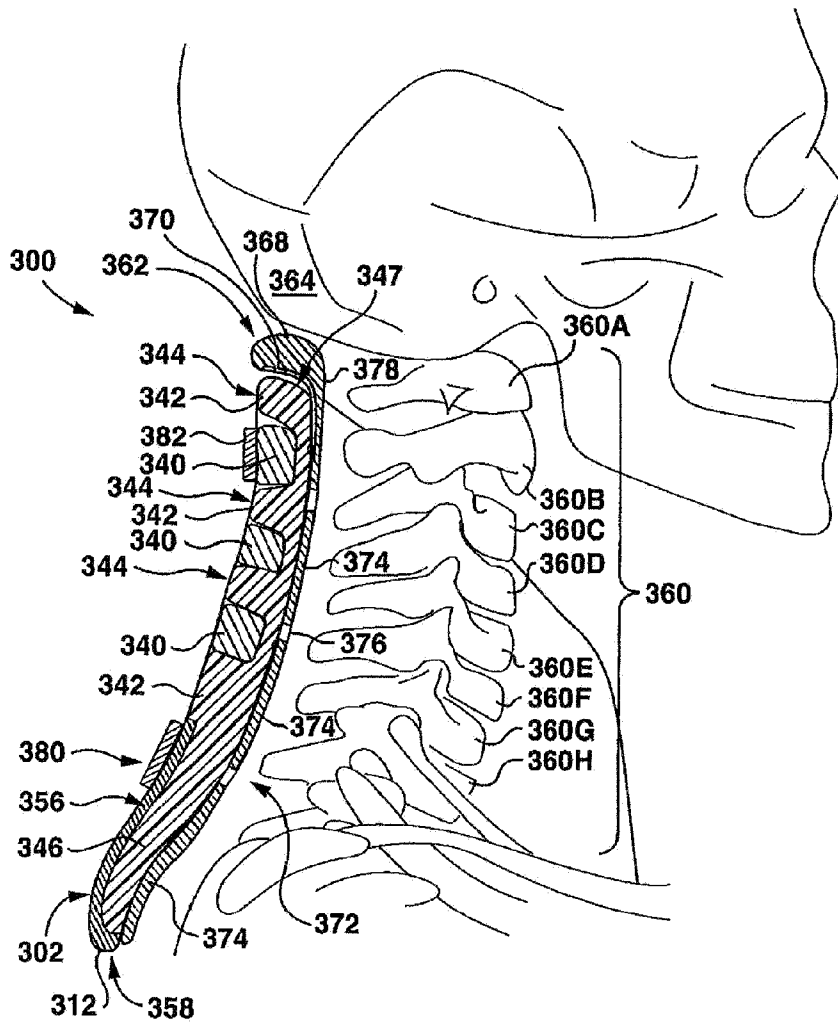

FIG. 27

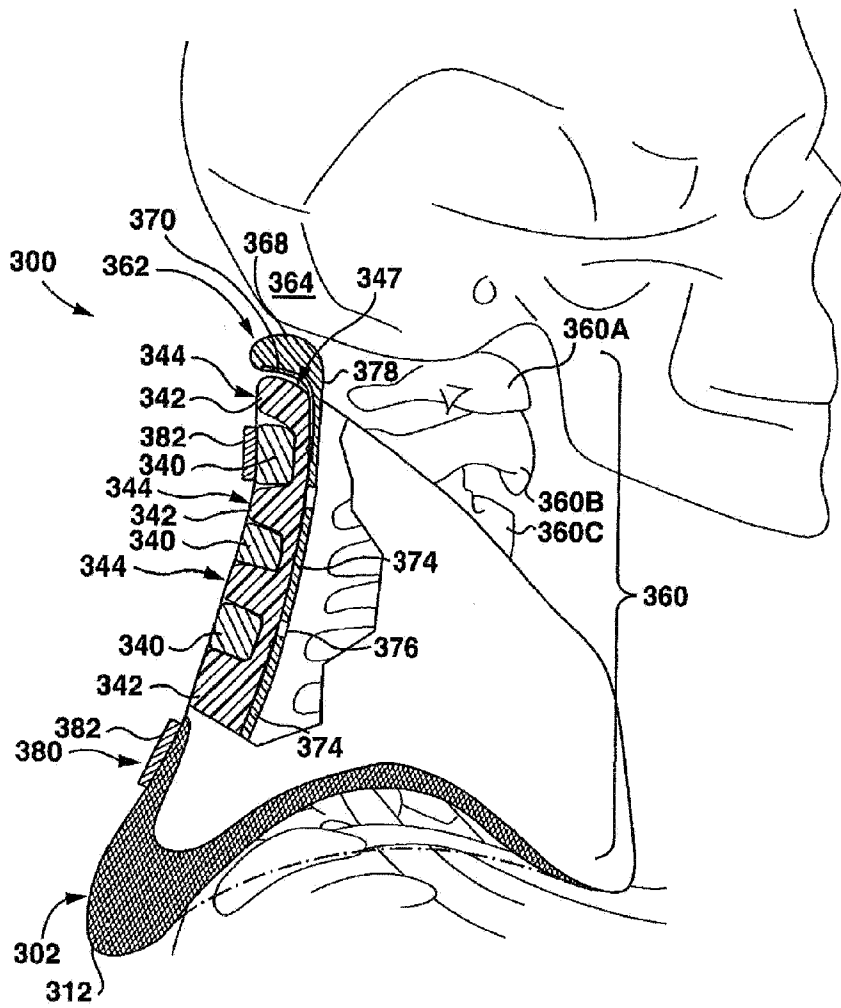

FIG. 28

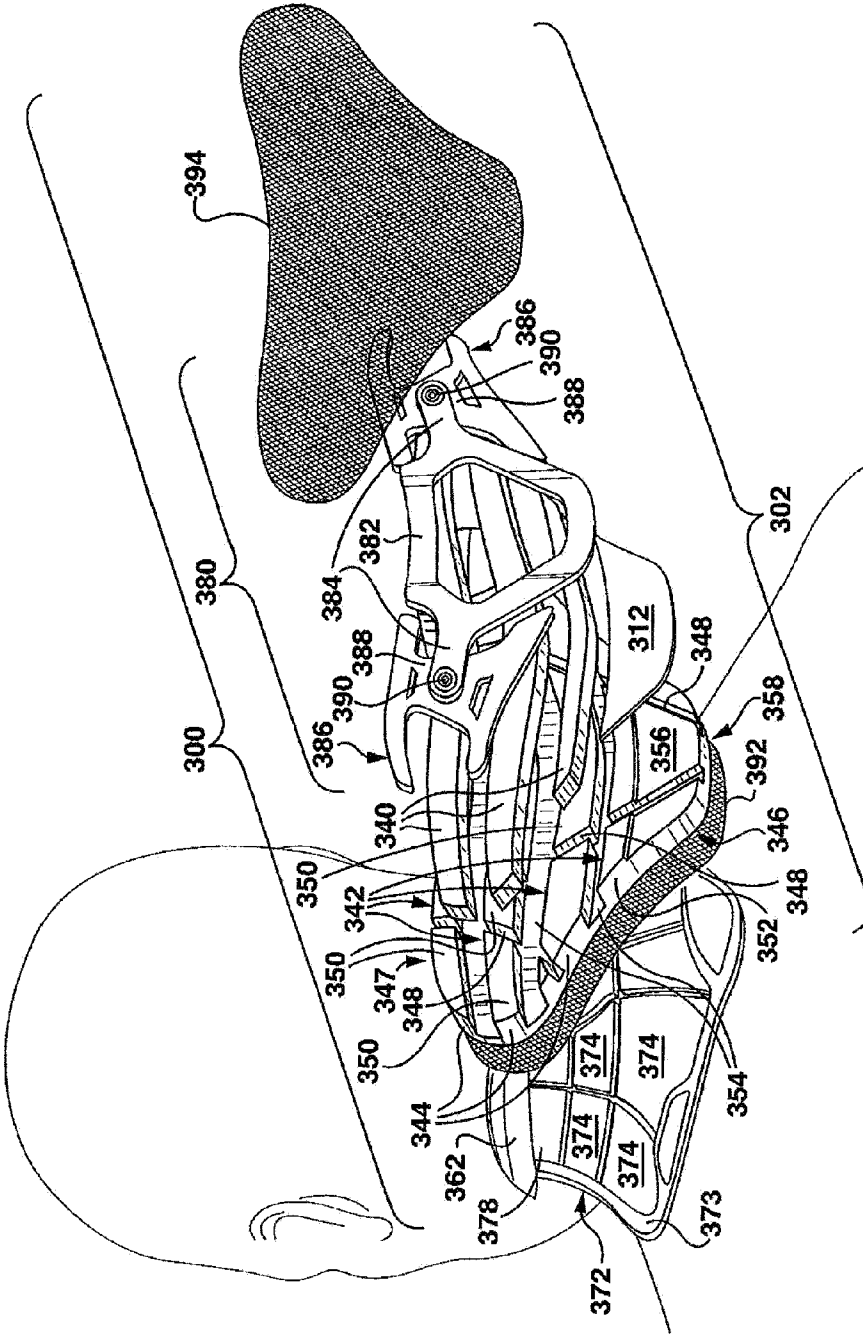

FIG. 30

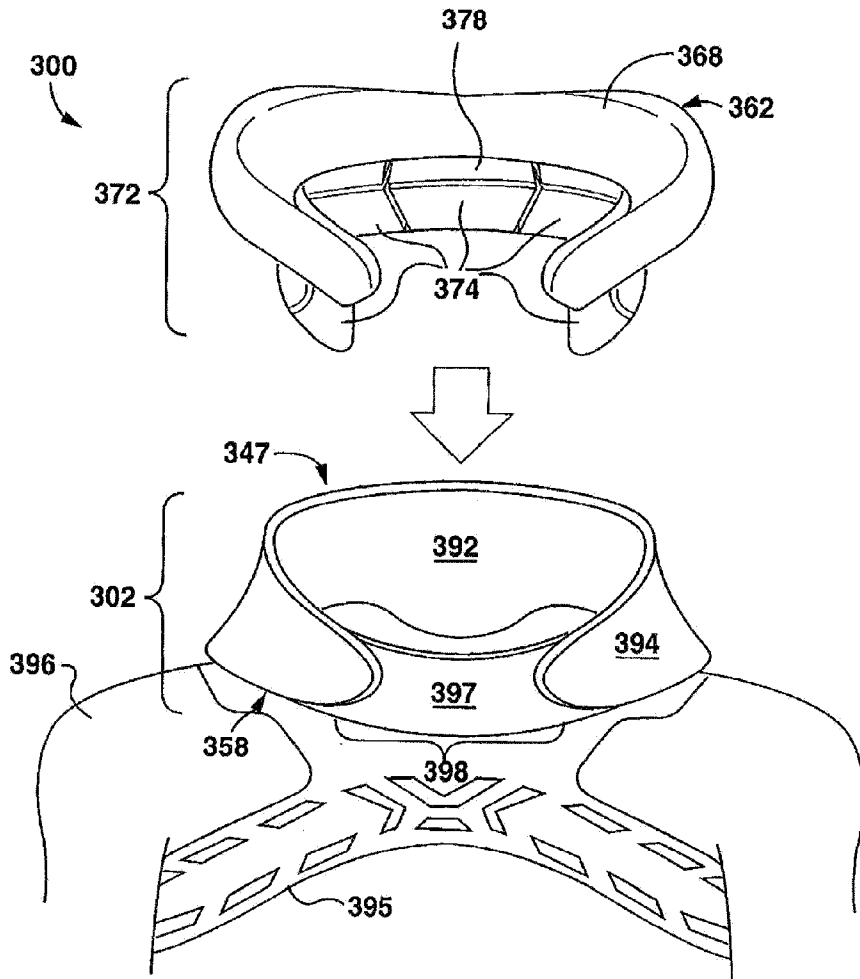

FIG. 31

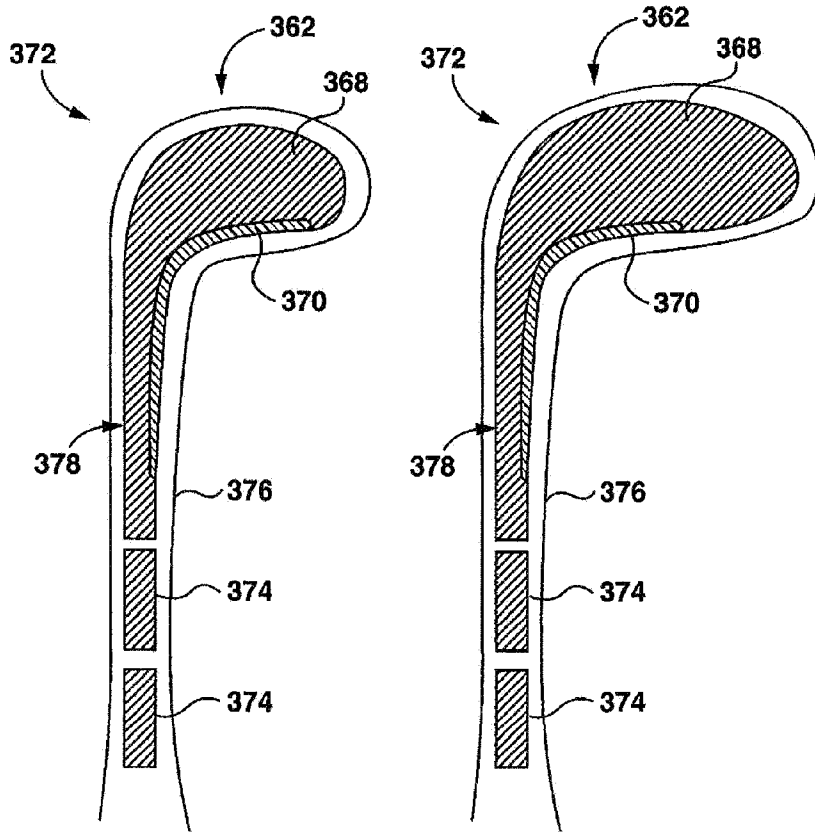

FIG. 32A

FIG. 32B

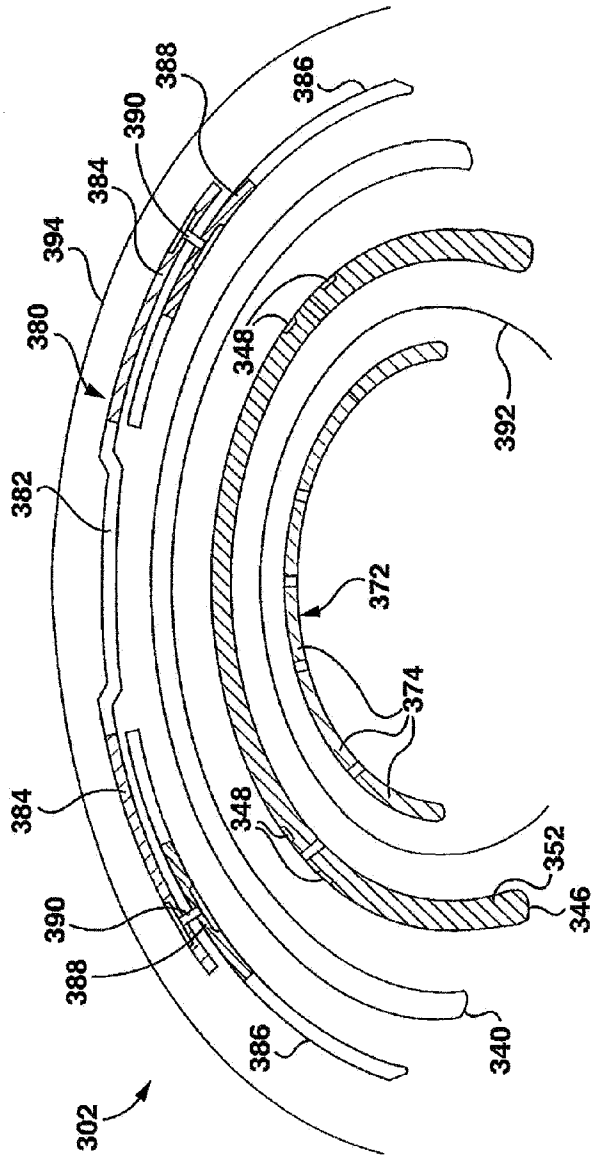

FIG. 33

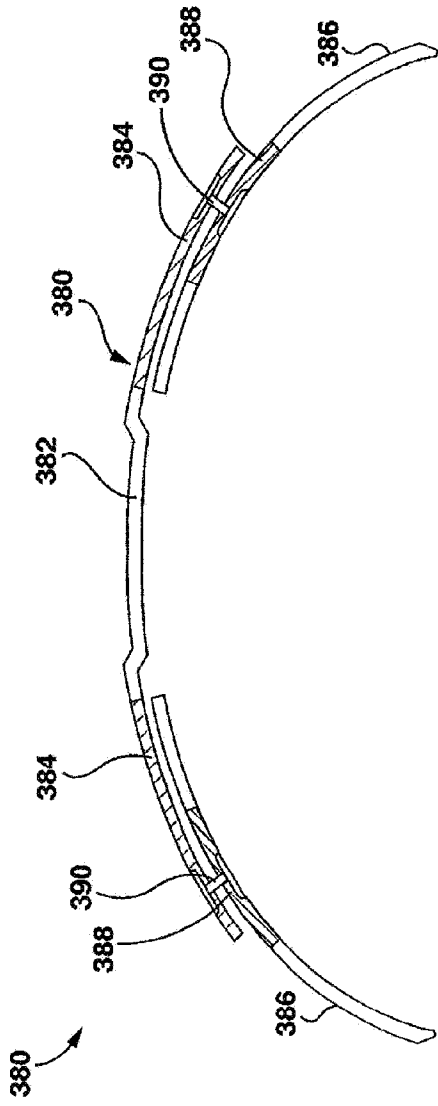

FIG. 35

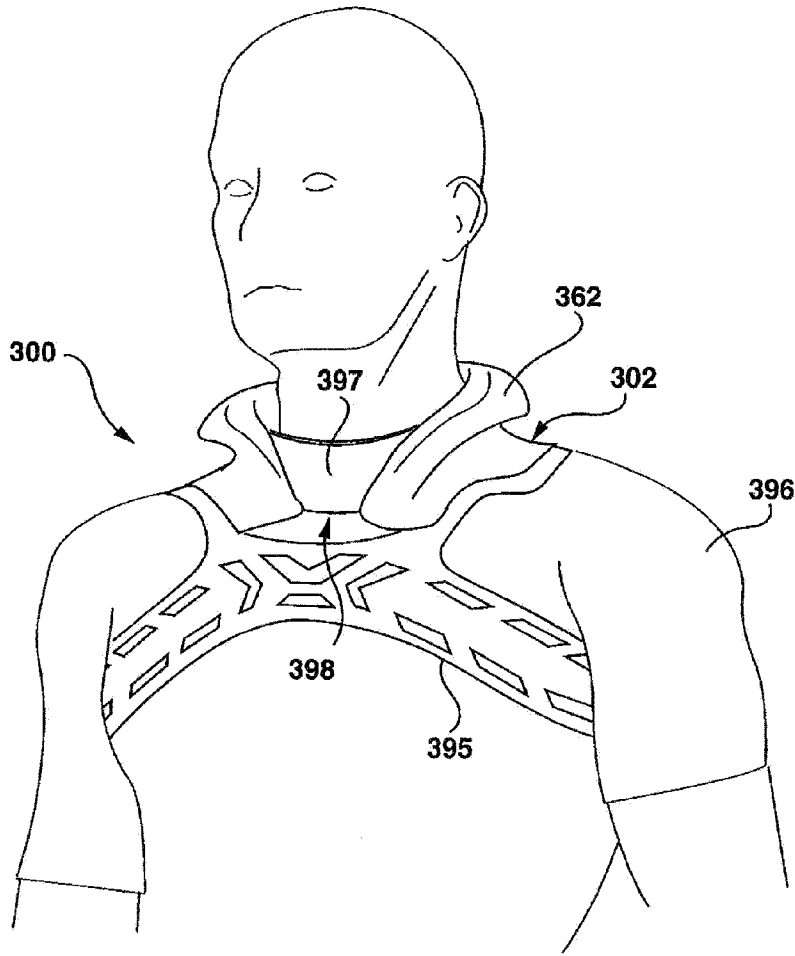

FIG. 36

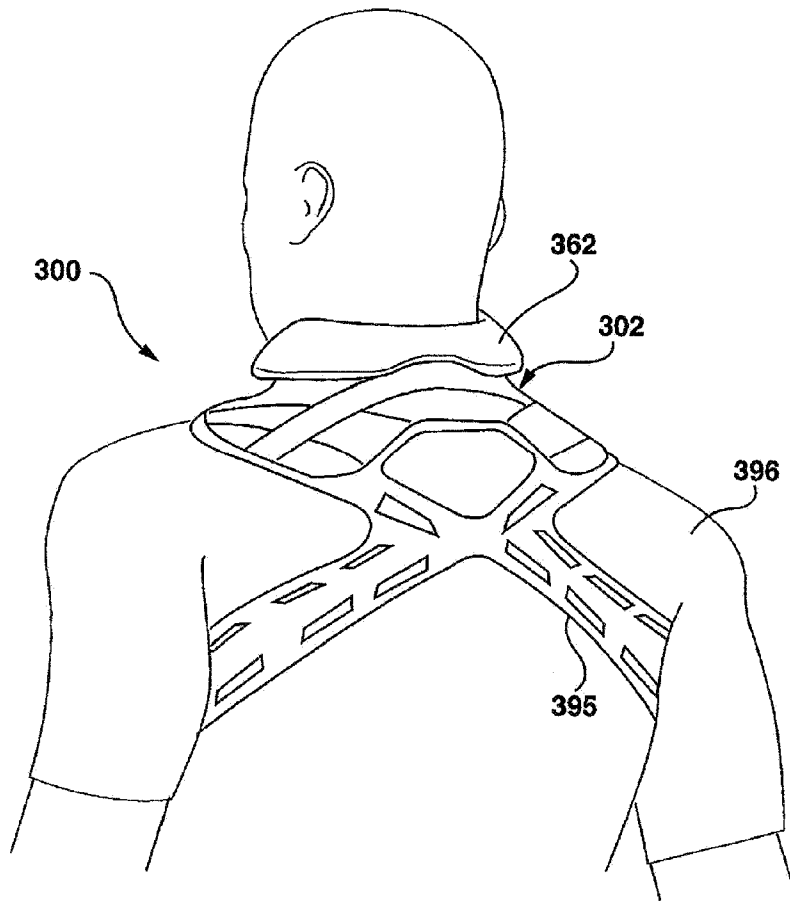

FIG. 37

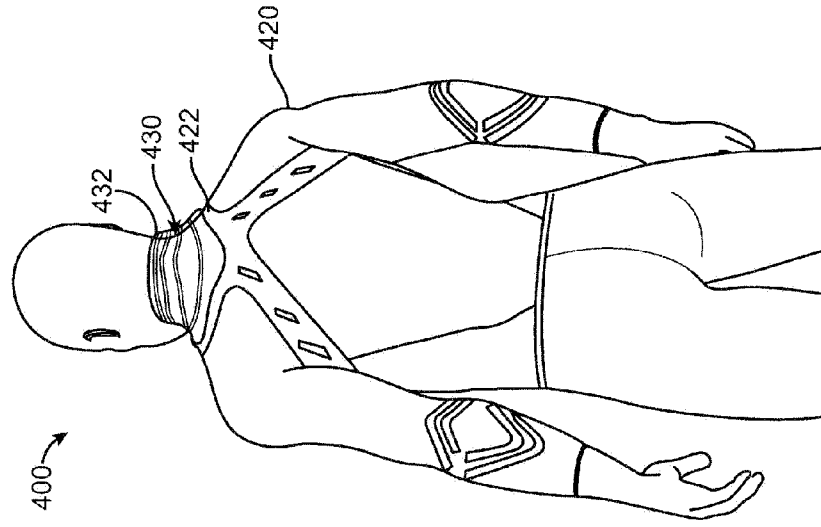

FIG. 41

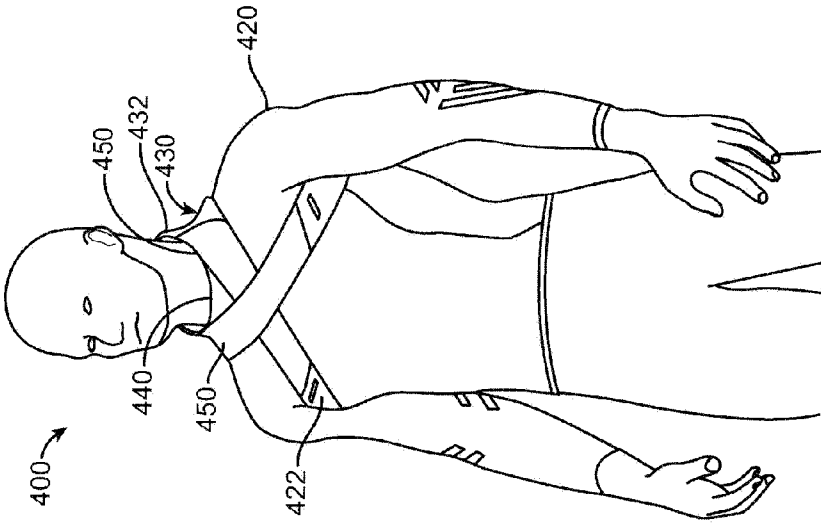

FIG. 40

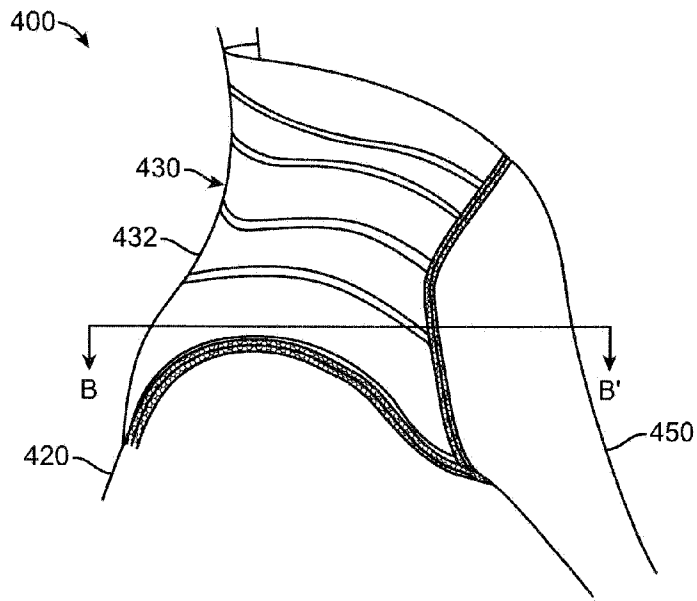

FIG. 42

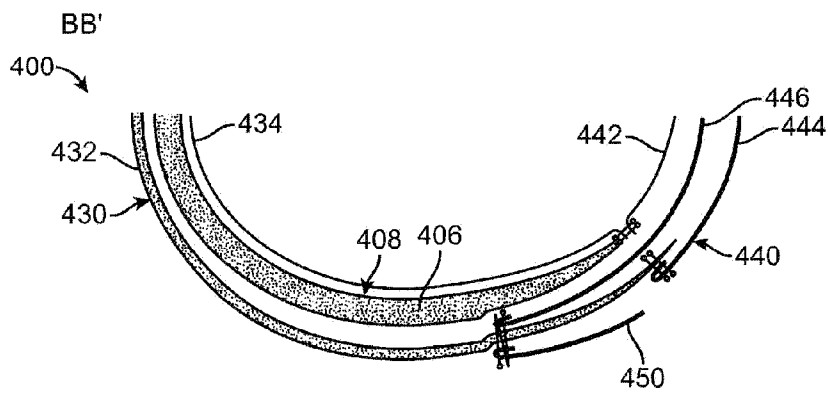

FIG. 43

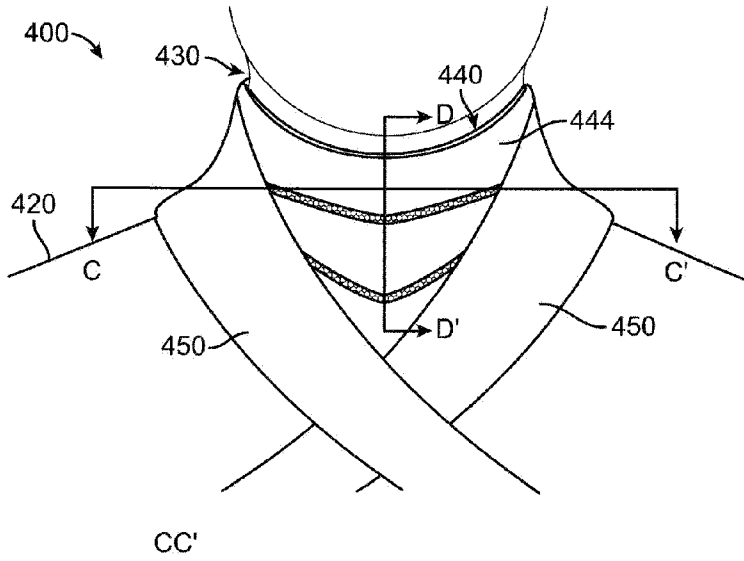

FIG. 44

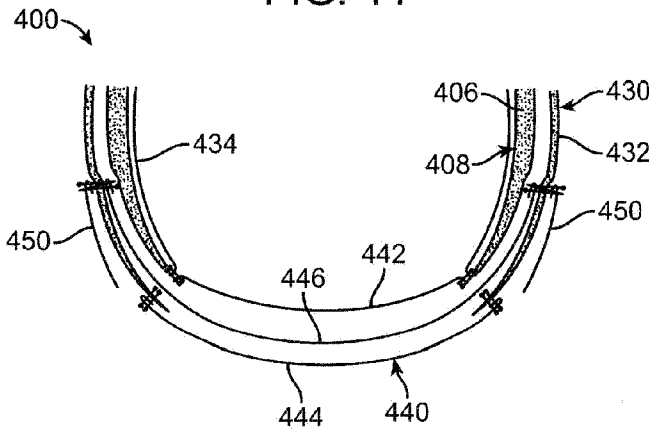

FIG. 45

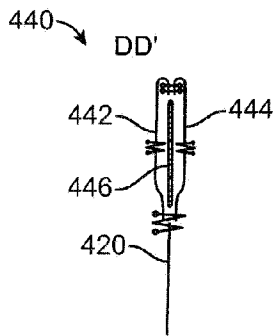

FIG. 46A

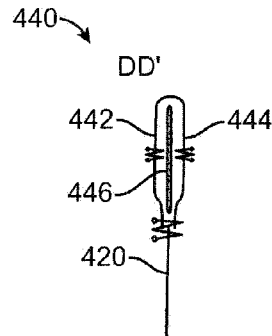

FIG. 46B

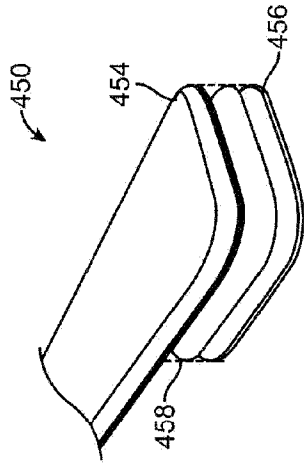

FIG. 48A

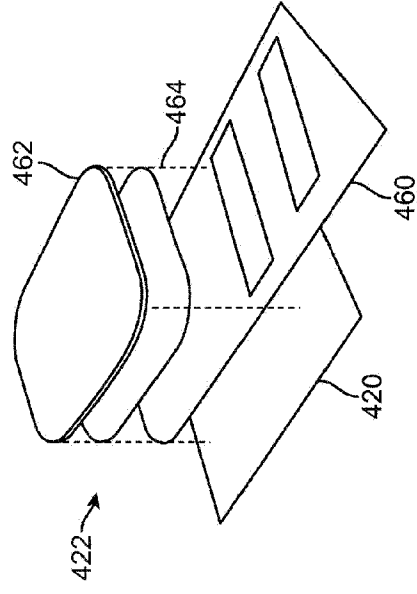

FIG. 48B

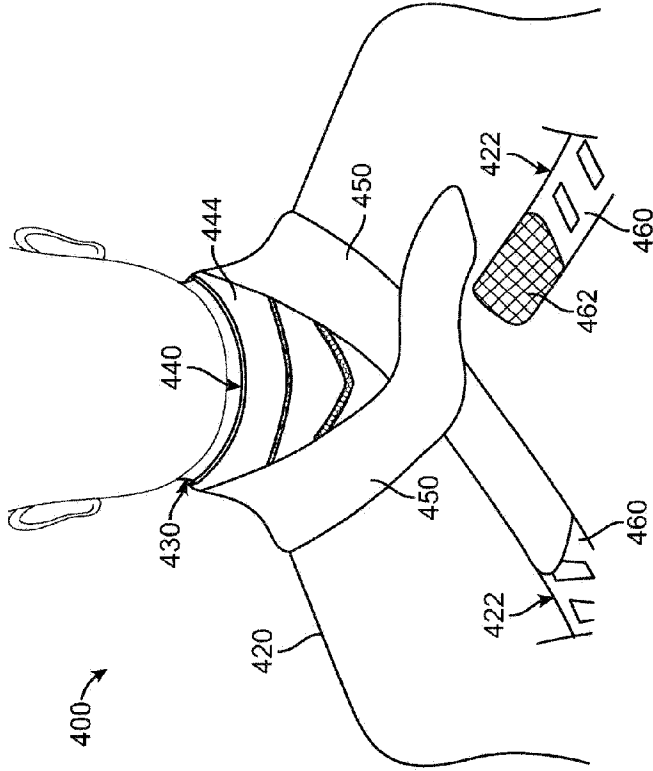

FIG. 47

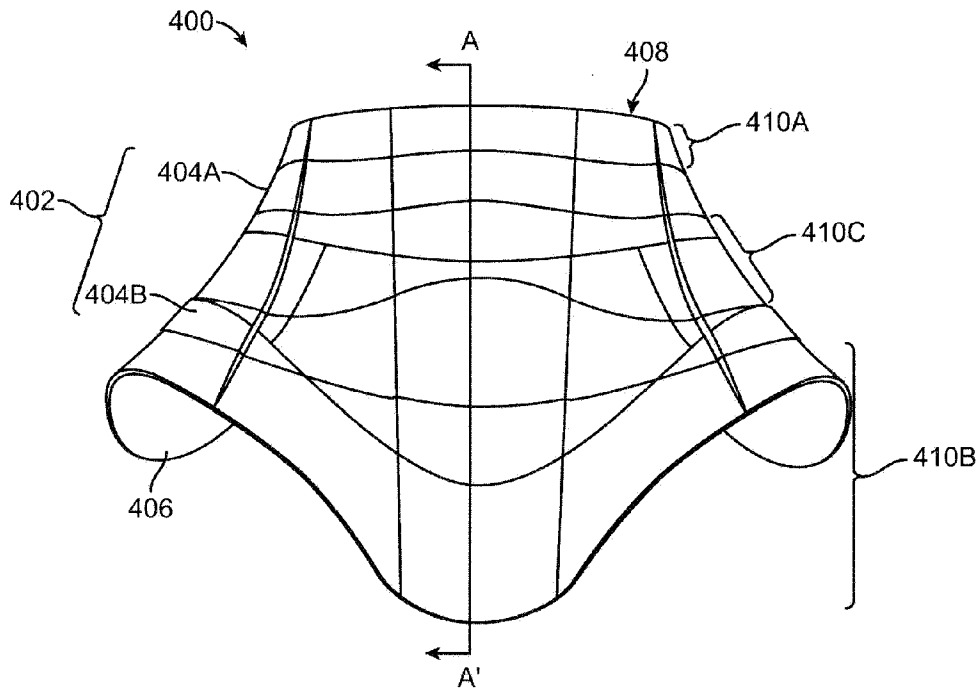

FIG. 49

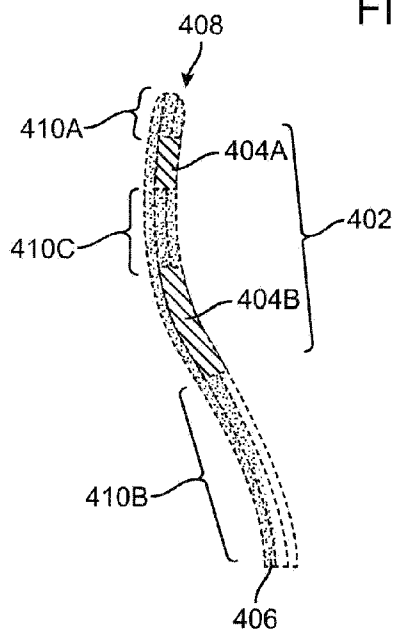

FIG. 50A

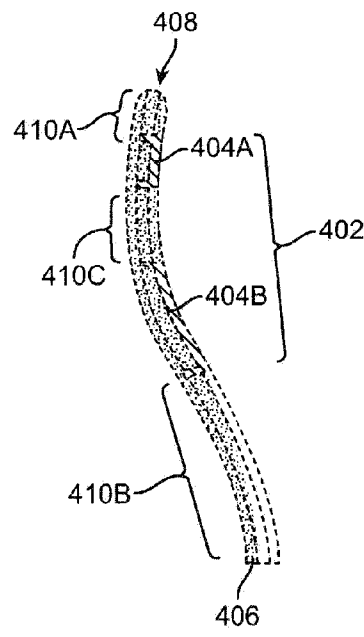

FIG. 50B

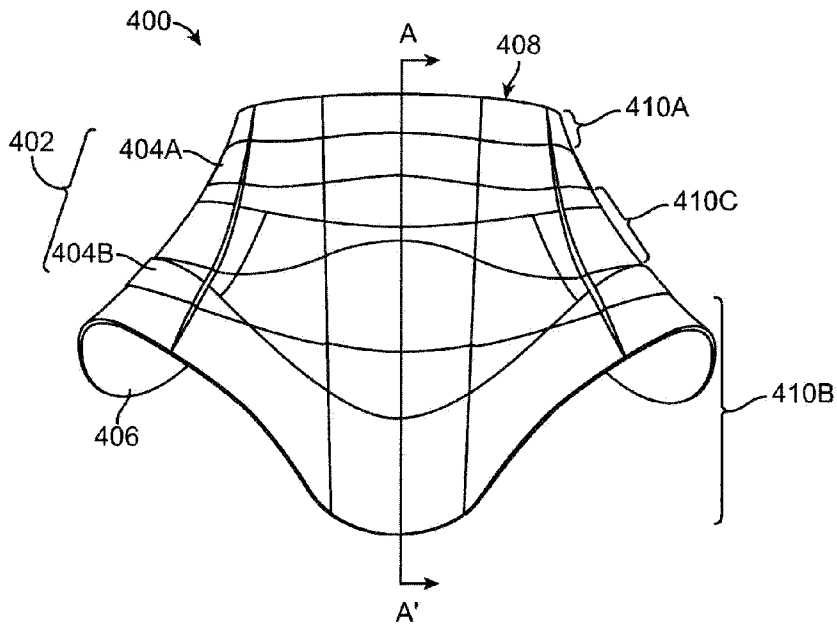

FIG. 51

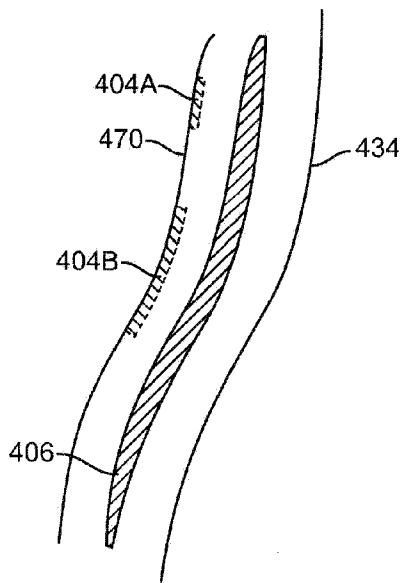

FIG. 52A

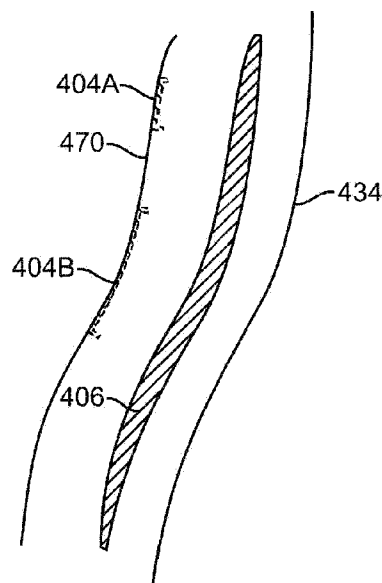

FIG. 52B

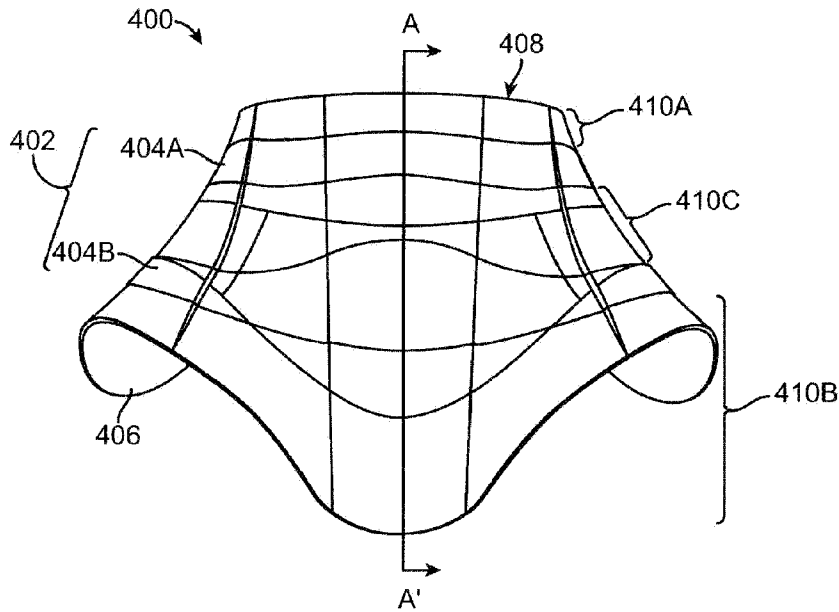

FIG. 53

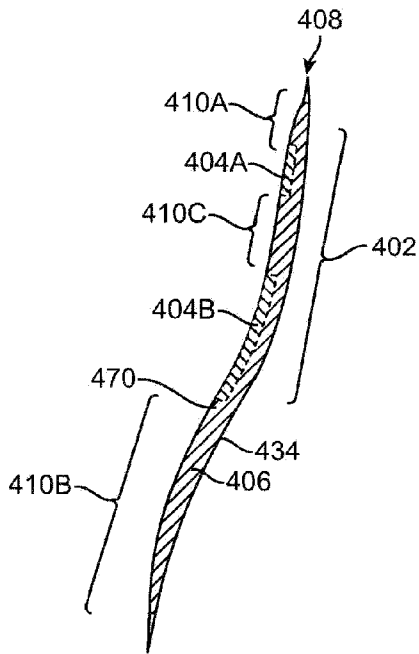

FIG. 54A

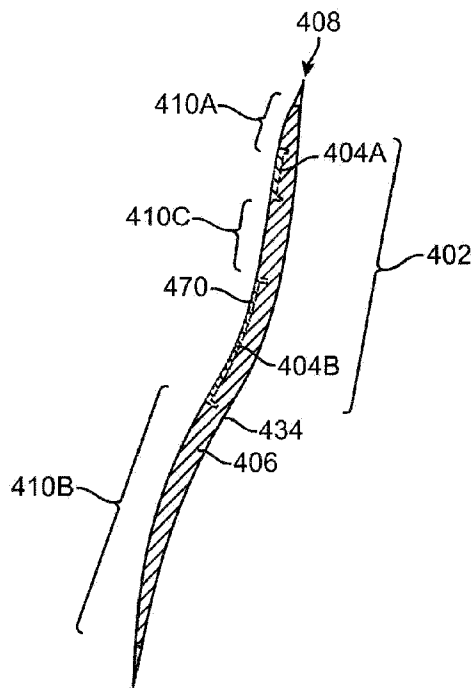

FIG. 54B

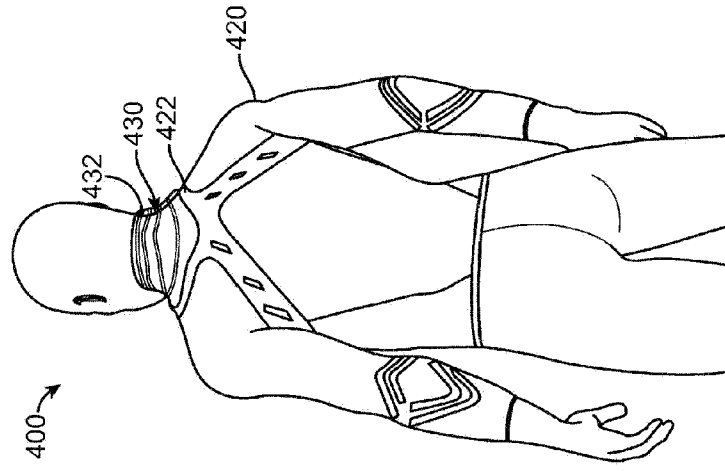

FIG. 56

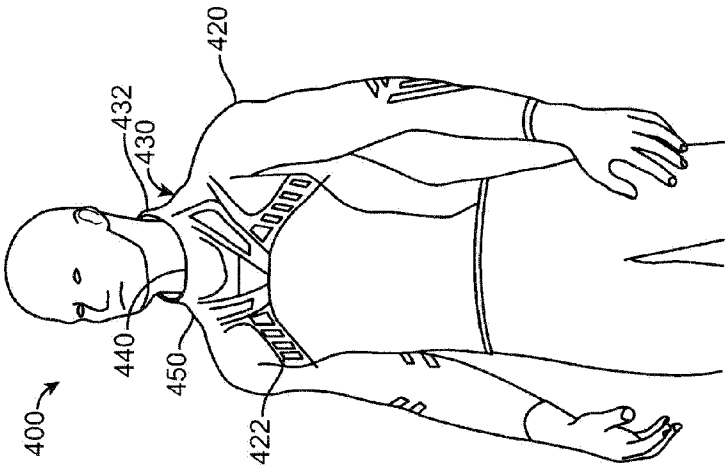

FIG. 55

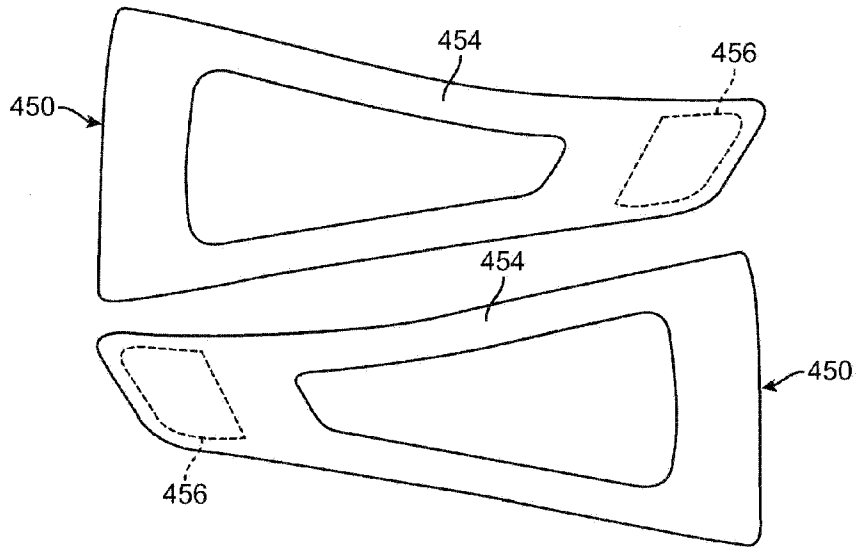

FIG. 57

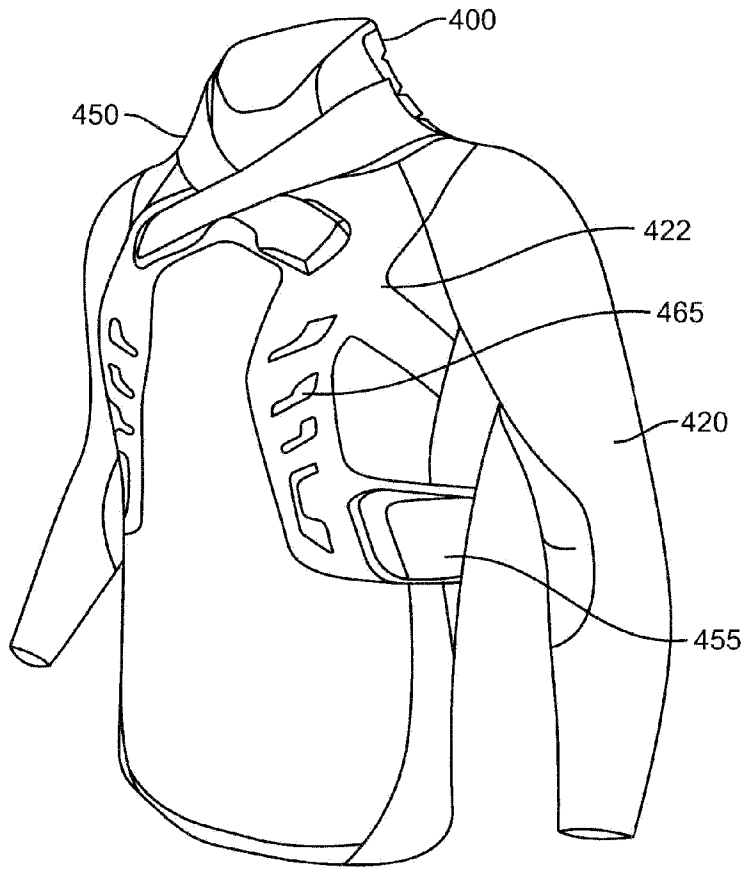

FIG. 58

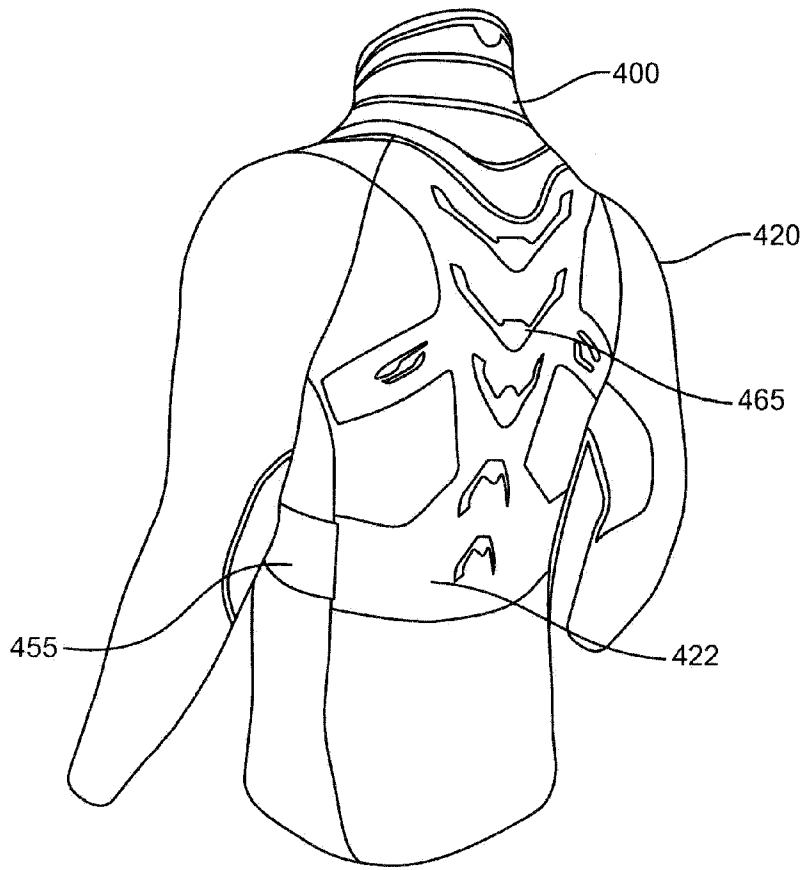

FIG. 59

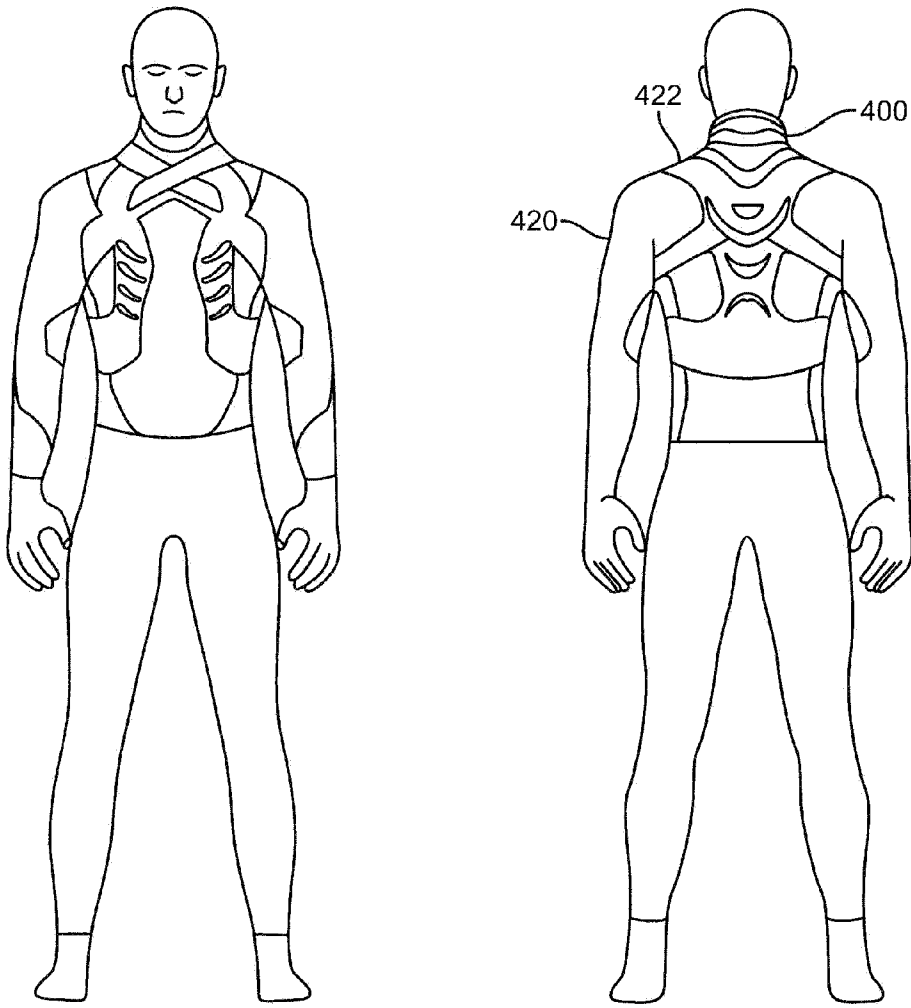

FIG. 60

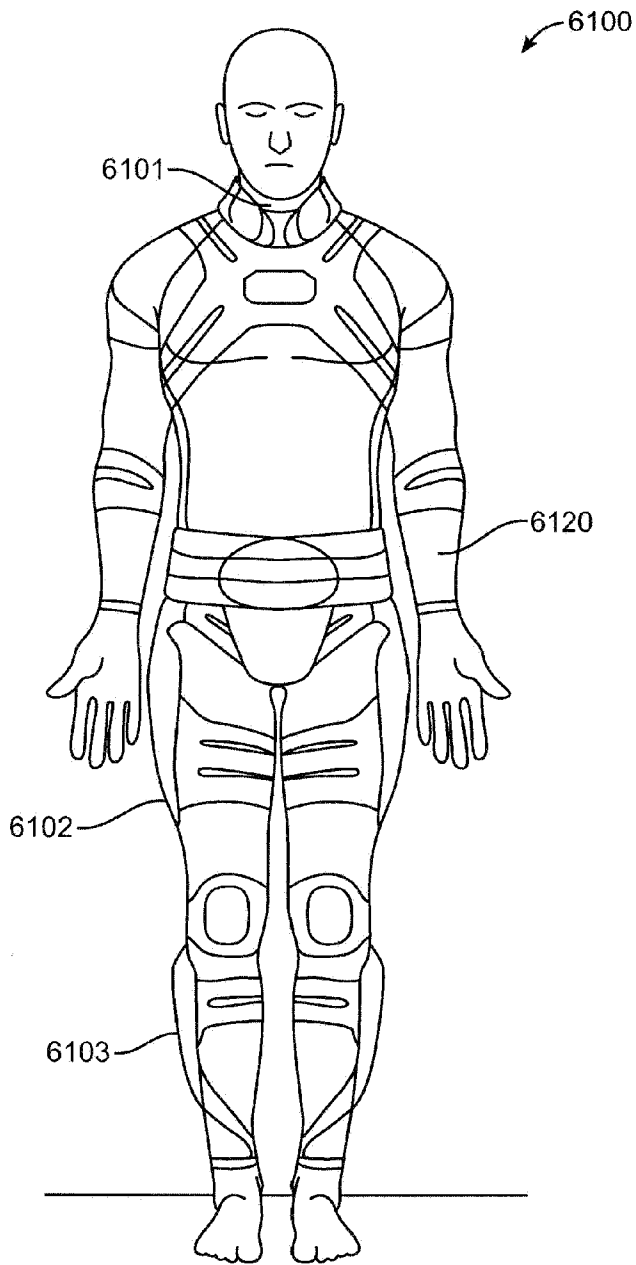

FIG. 61A

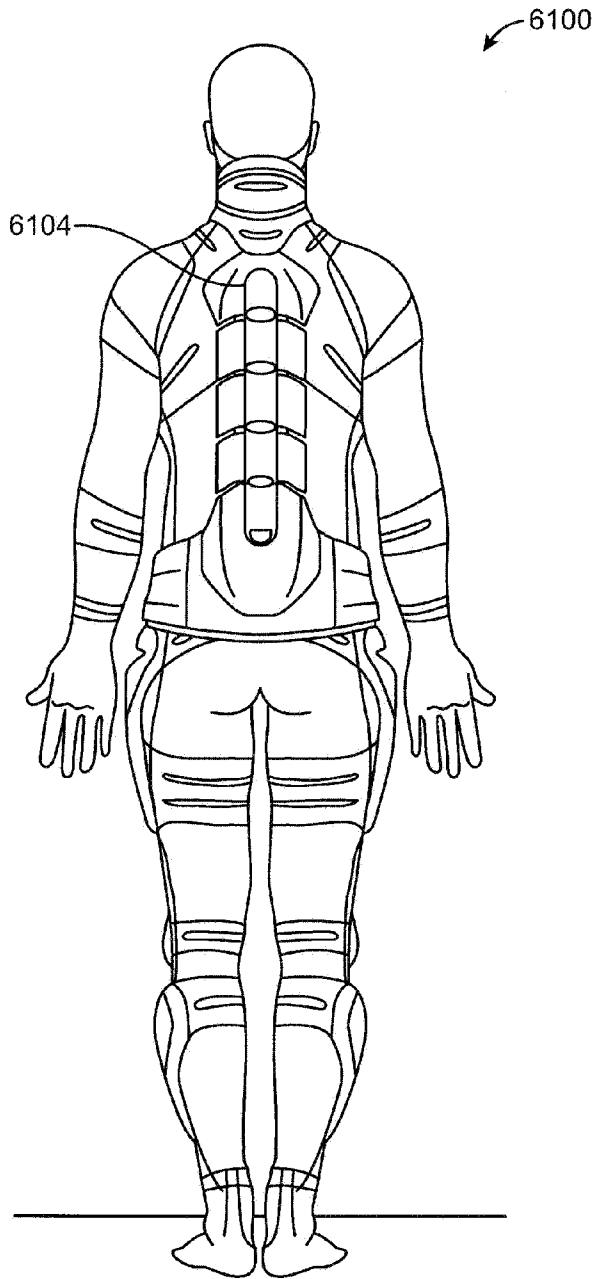

FIG. 61B

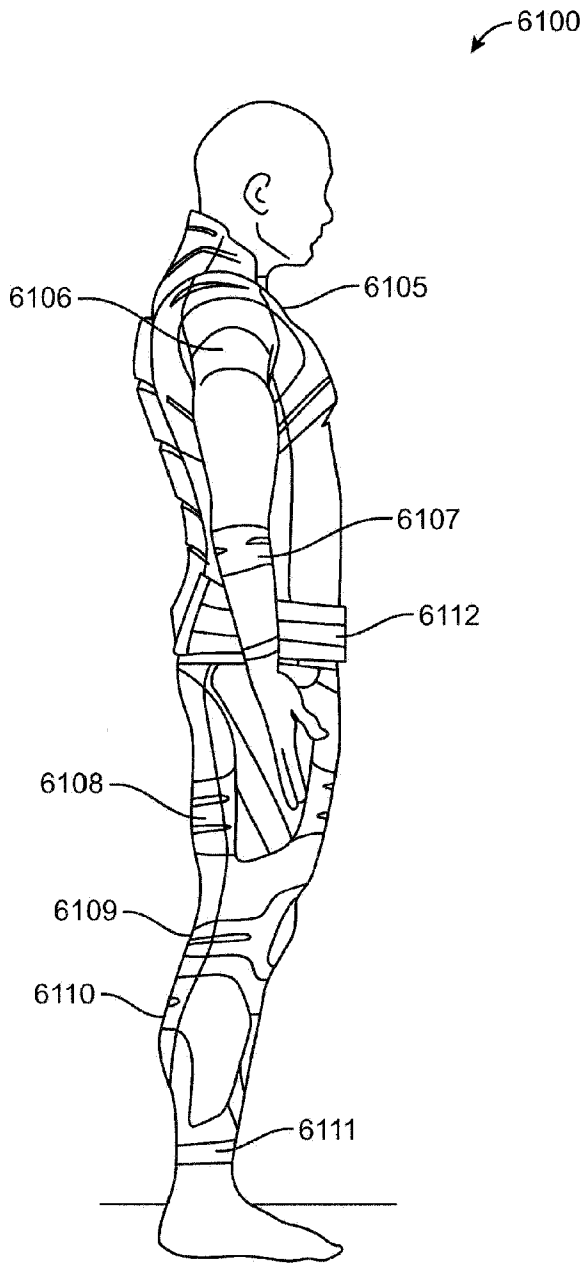

FIG. 61C

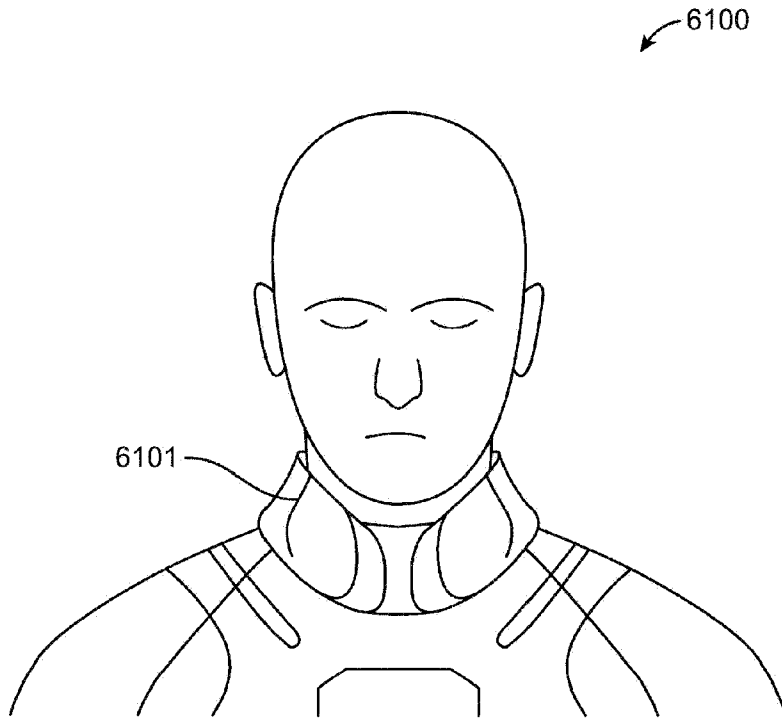

FIG. 61D

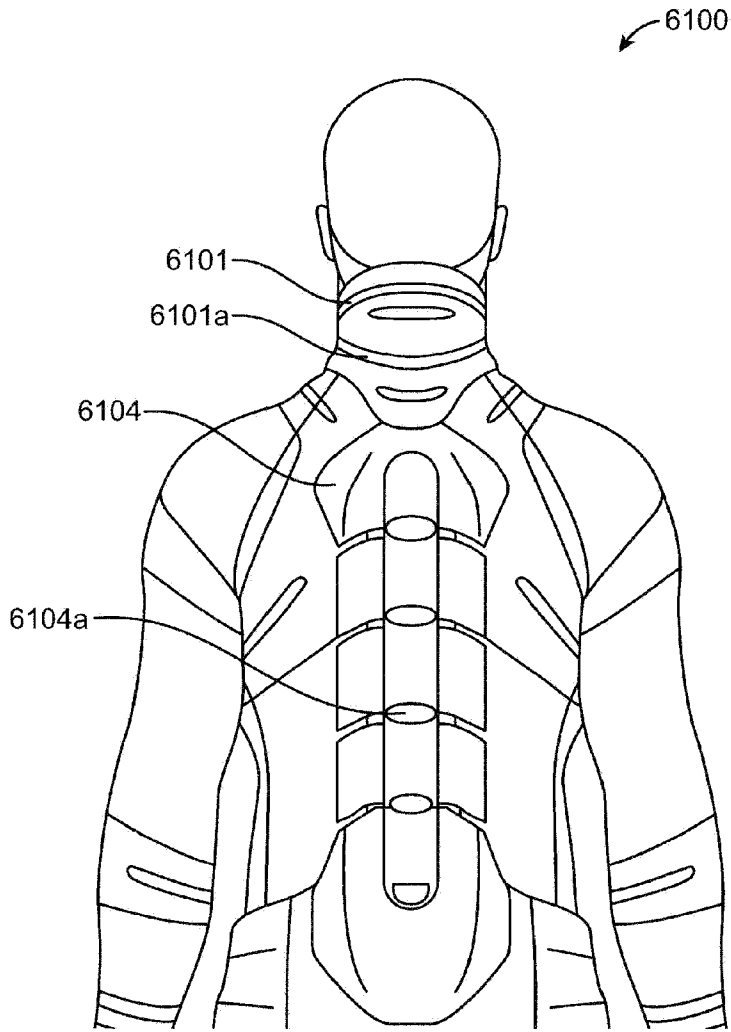

FIG. 61E

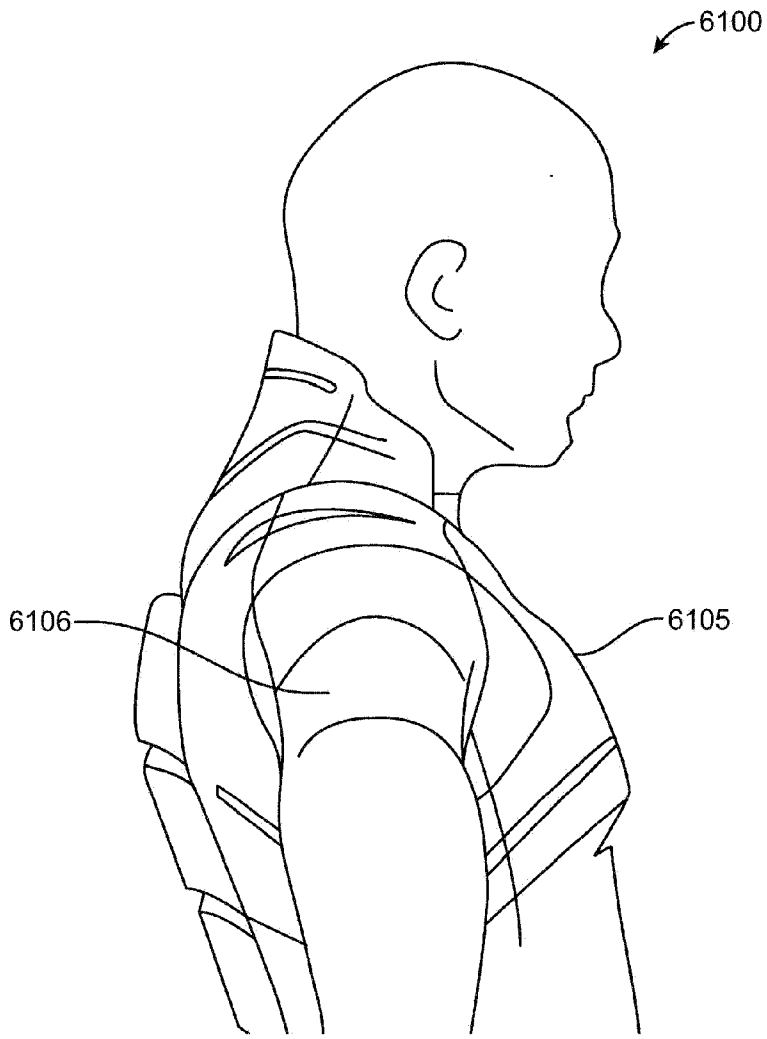

FIG. 61F

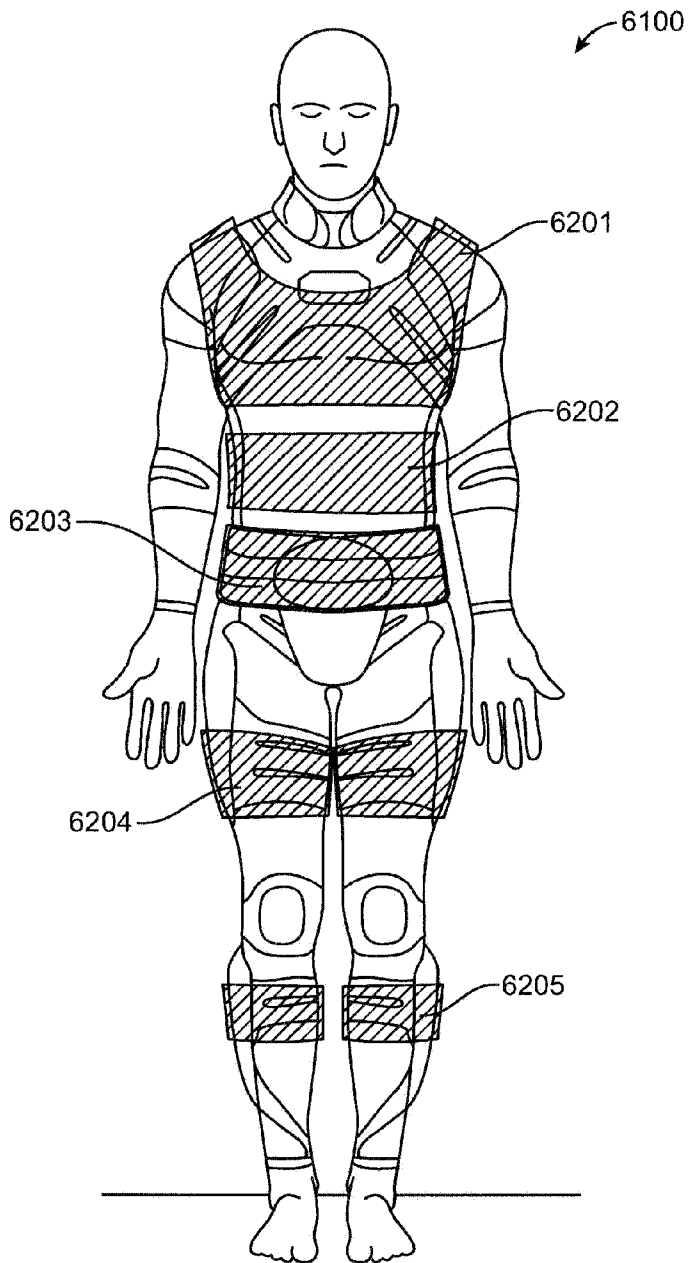

FIG. 62A

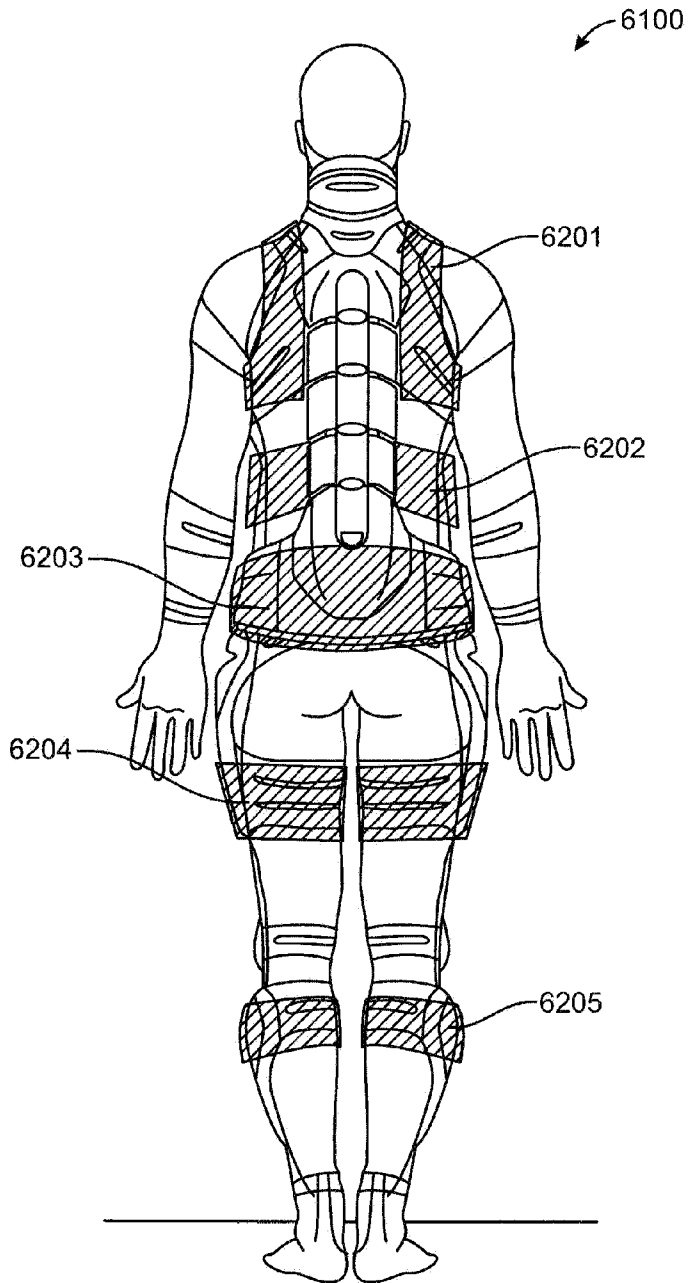

FIG. 62B

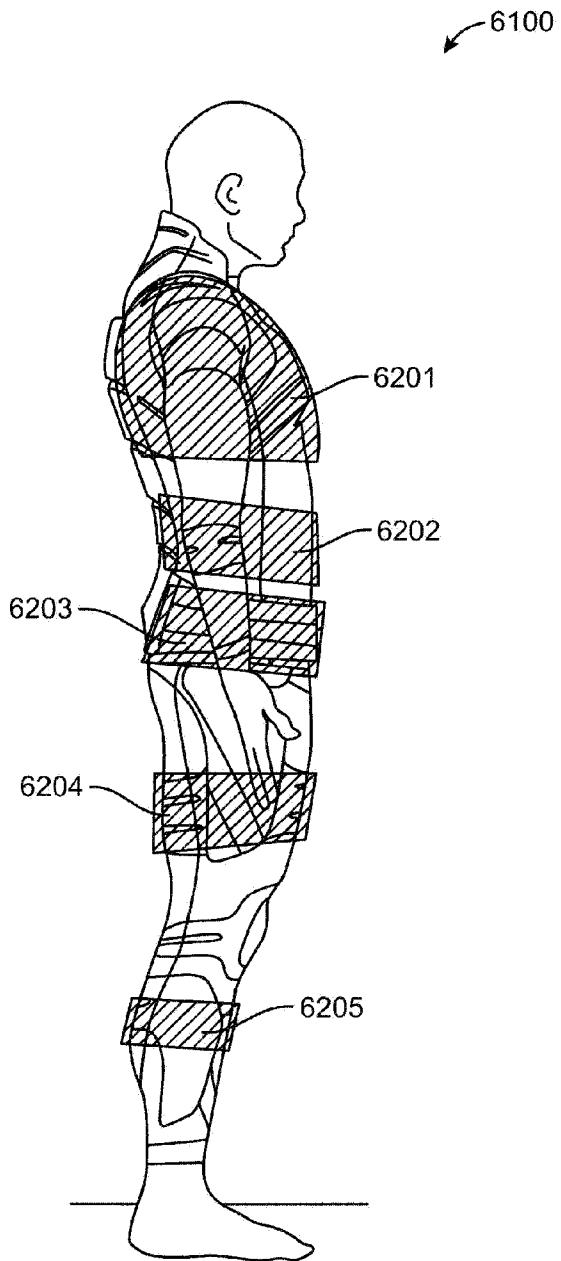

FIG. 62C

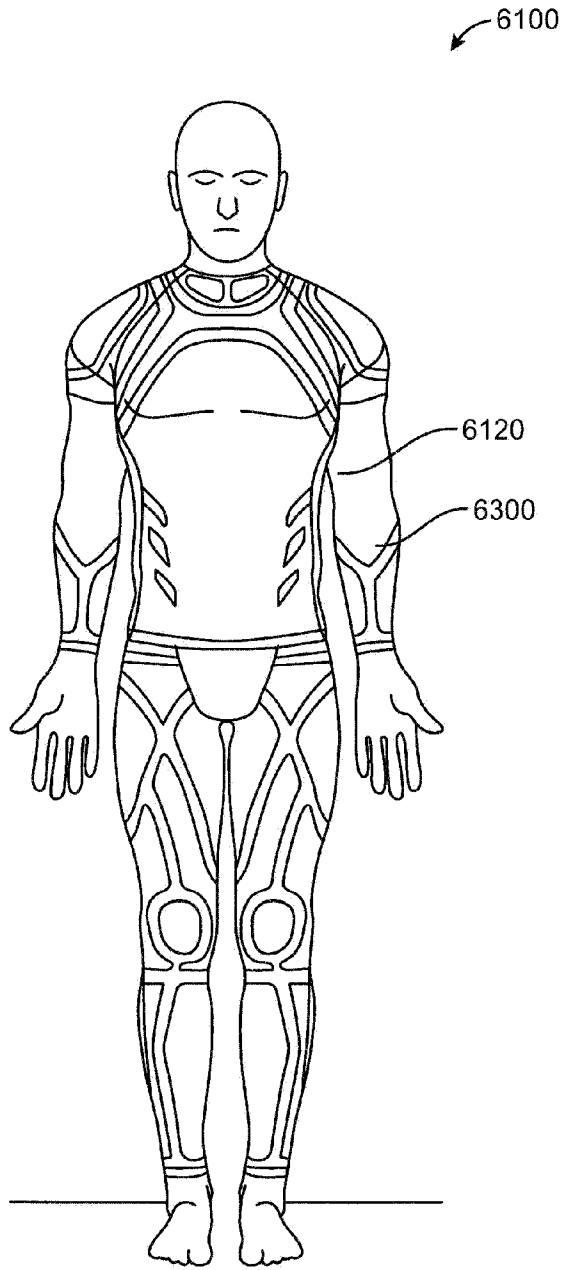

FIG. 63A

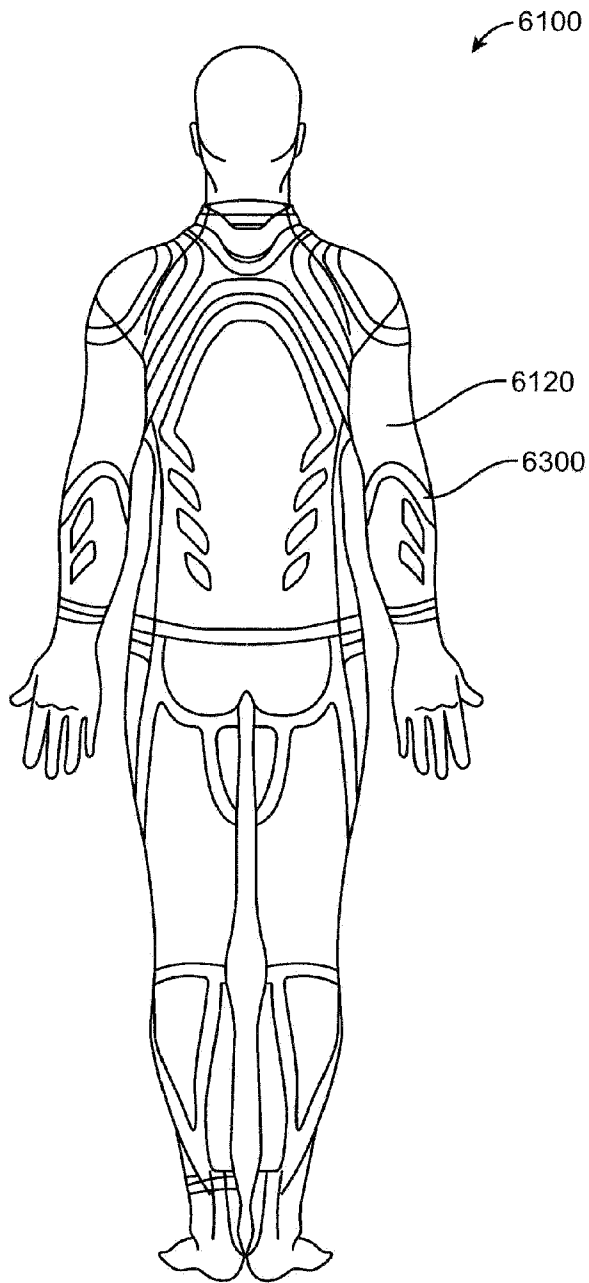

FIG. 63B

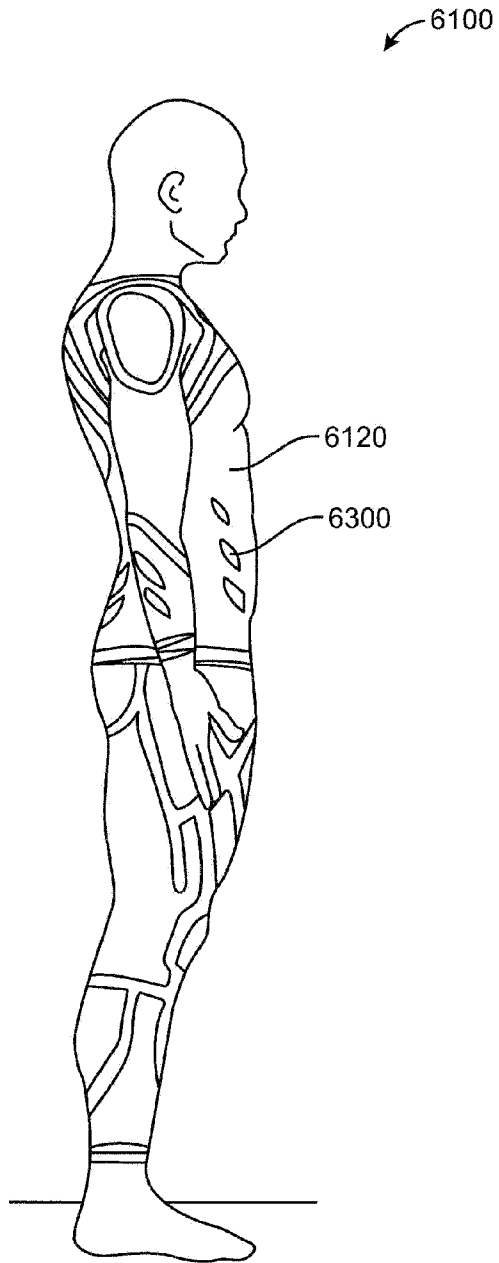

FIG. 63C

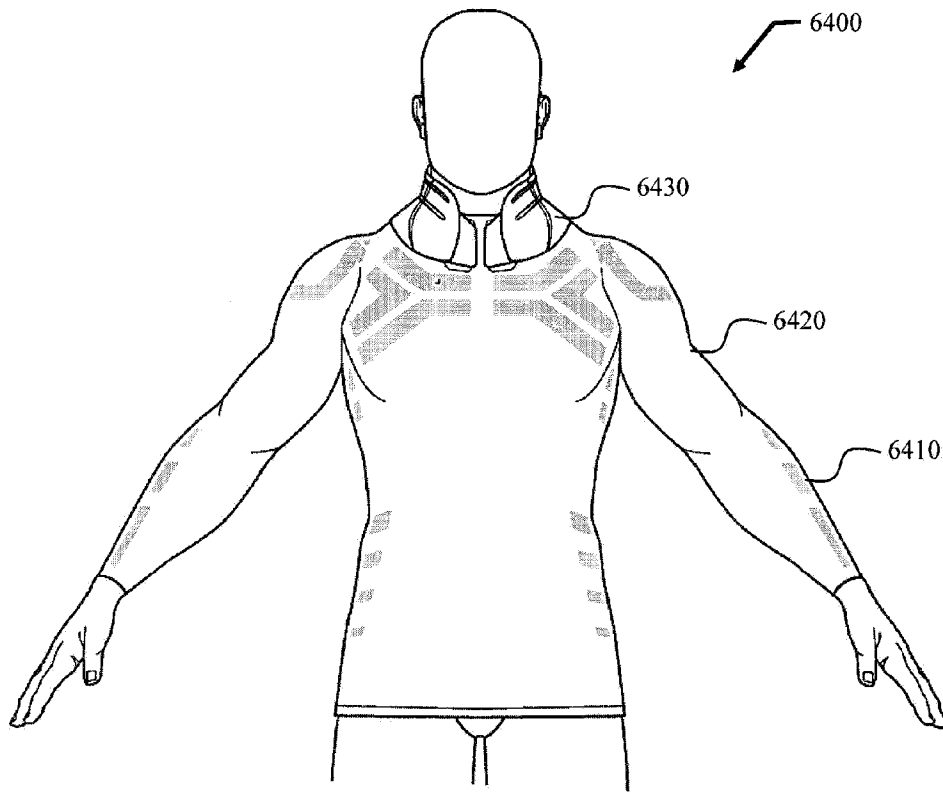

FIG. 64A

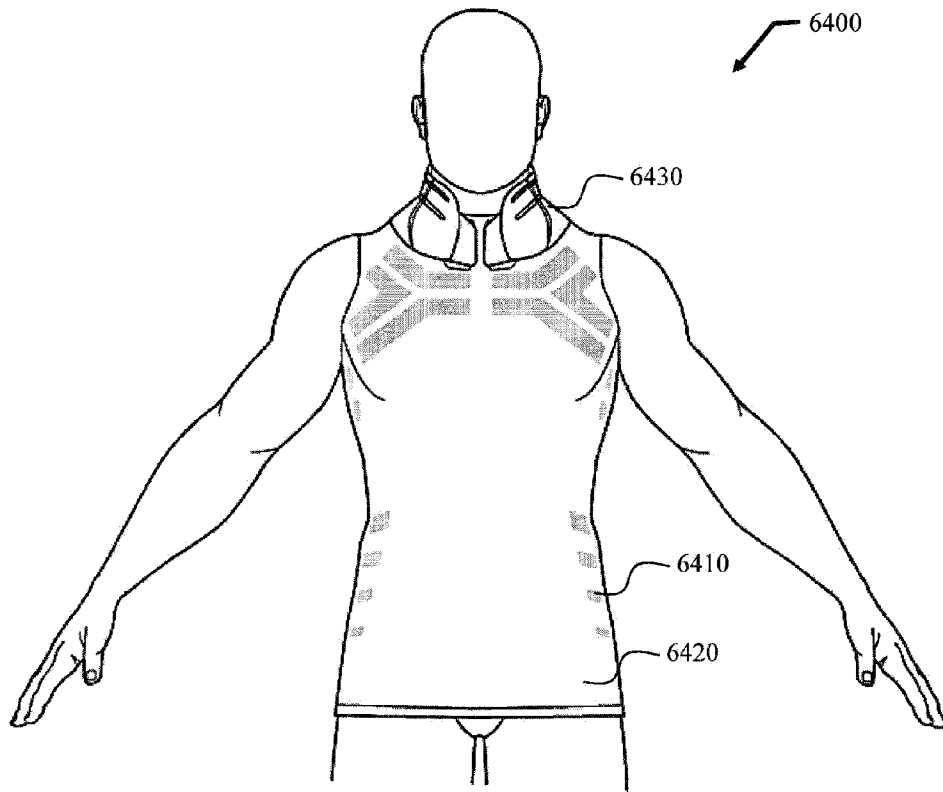

FIG. 64B

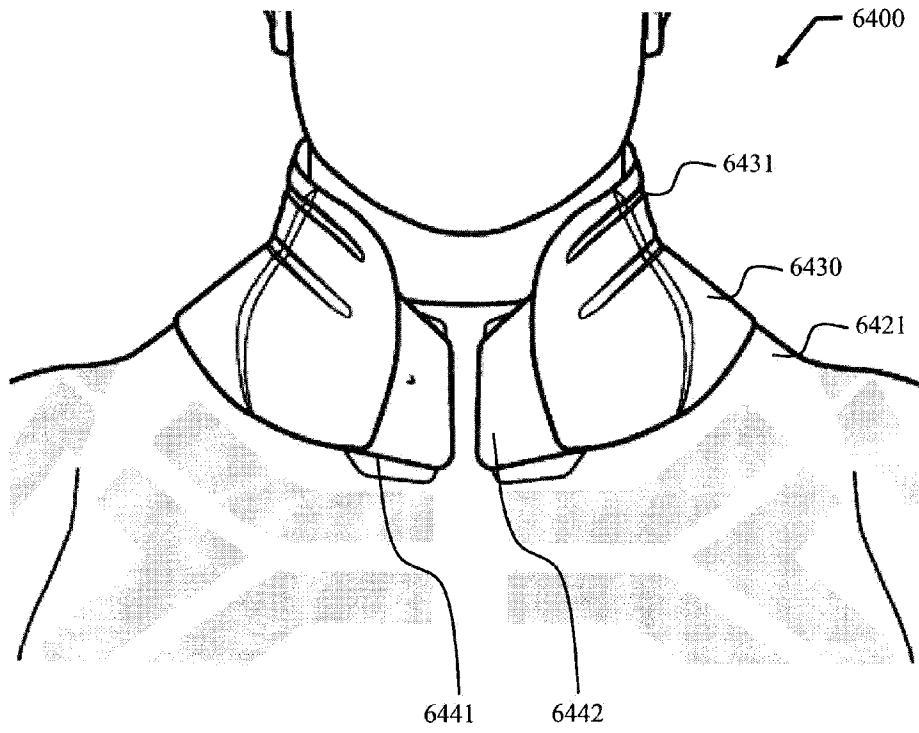

FIG. 64C

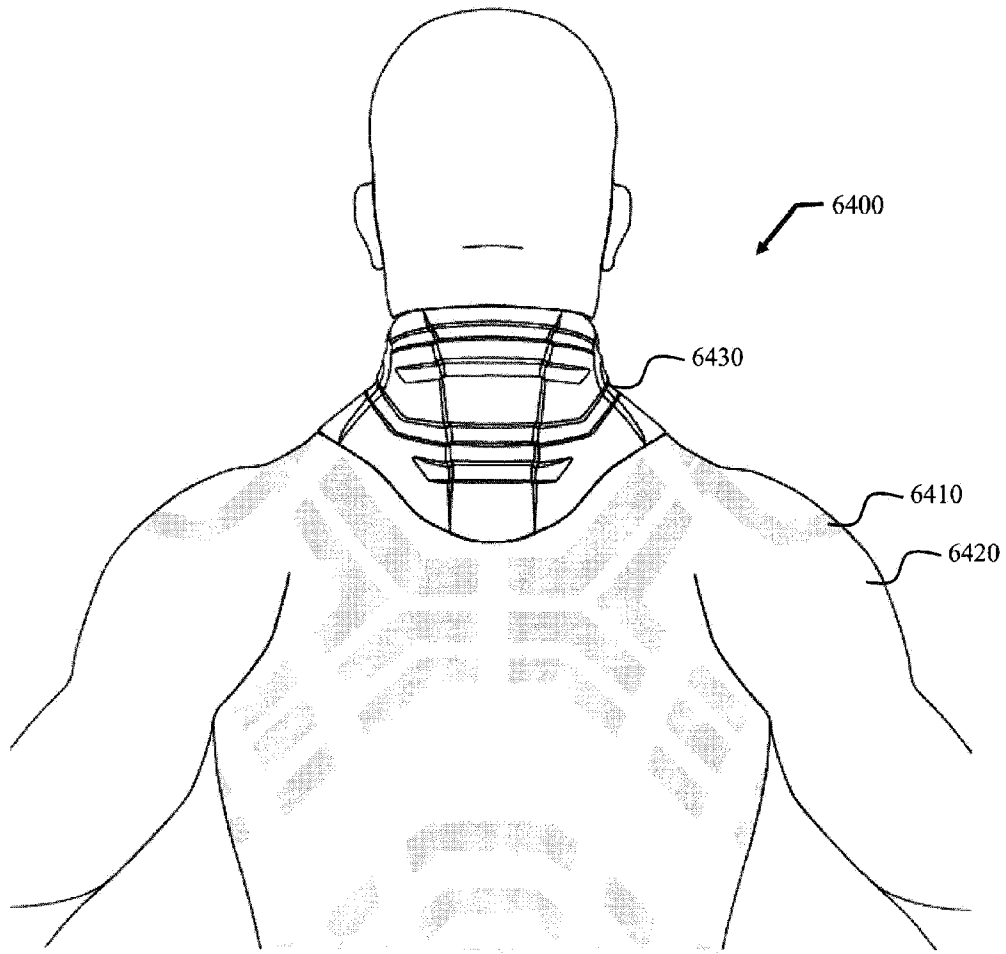

FIG. 64D

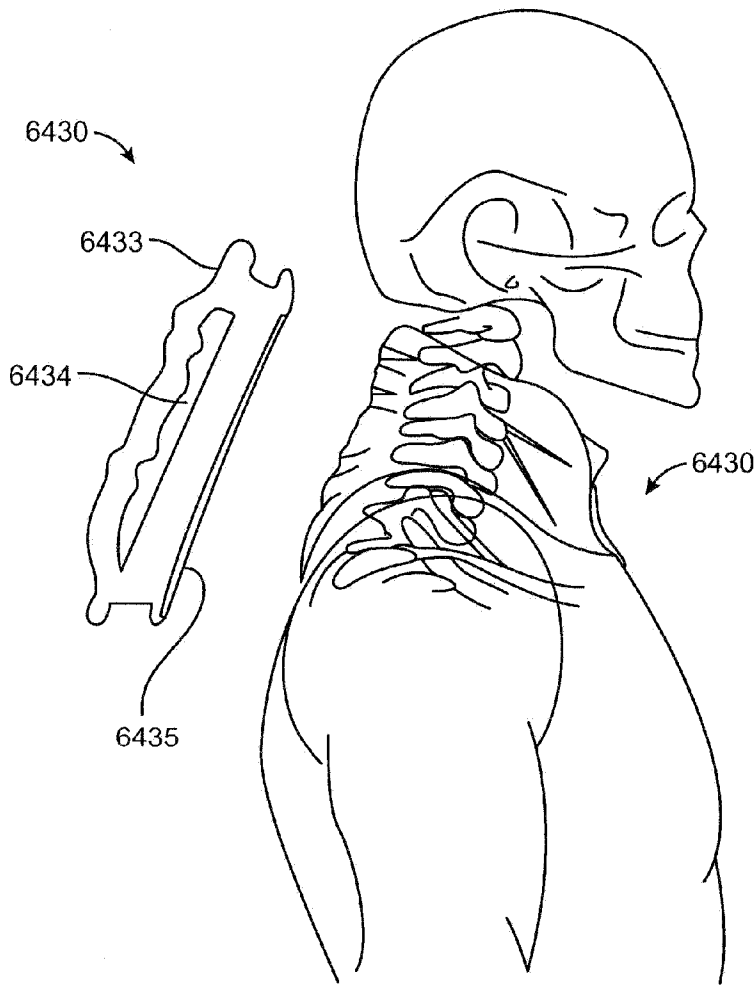

FIG. 64E