



- (51) International Patent Classification:  
*H05B 6/64* (2006.01) *H05B 6/68* (2006.01)
- (21) International Application Number:  
PCT/IB2014/000224
- (22) International Filing Date:  
28 February 2014 (28.02.2014)
- (25) Filing Language: English
- (26) Publication Language: English
- (30) Priority Data:  
13380005.2 1 March 2013 (01.03.2013) EP
- (71) Applicant: **LEKUE, SL** [ES/ES]; C/ Barcelona, 16, E-08120 La Llagosta (Barcelona) (ES).
- (72) Inventors: **COSTA BARRIGA, Xavier**; C/Covadonga, 384, 4t 2a, E-08203 Sabadell (Barcelona) (ES). **TATCHE LLONCH, Josep**; C/Capmany, 4, 3r B, E-08201 Sabadell (Barcelona) (ES). **CASTELLS ESQUÉ, Pere**; Camí de Sant Benet, s/n, E-08272 Sant Fruitós De Bages (Barcelona) (ES). **COSTA LLONCH, Xavier**; C/Barcelona, 16, E-08120 La Llagosta (Barcelona) (ES).
- (74) Agent: **JUNCOSA MIRÓ, Jaime**; Torner, Juncosa I Associats, SL, Gran Via de les Corts Catalanes, 669 bis, 1r. 2a., E-08013 Barcelona (ES).

(81) Designated States (unless otherwise indicated, for every kind of national protection available): AE, AG, AL, AM, AO, AT, AU, AZ, BA, BB, BG, BH, BN, BR, BW, BY, BZ, CA, CH, CL, CN, CO, CR, CU, CZ, DE, DK, DM, DO, DZ, EC, EE, EG, ES, FI, GB, GD, GE, GH, GM, GT, HN, HR, HU, ID, IL, IN, IR, IS, JP, KE, KG, KN, KP, KR, KZ, LA, LC, LK, LR, LS, LT, LU, LY, MA, MD, ME, MG, MK, MN, MW, MX, MY, MZ, NA, NG, NI, NO, NZ, OM, PA, PE, PG, PH, PL, PT, QA, RO, RS, RU, RW, SA, SC, SD, SE, SG, SK, SL, SM, ST, SV, SY, TH, TJ, TM, TN, TR, TT, TZ, UA, UG, US, UZ, VC, VN, ZA, ZM, ZW.

(84) Designated States (unless otherwise indicated, for every kind of regional protection available): ARIPO (BW, GH, GM, KE, LR, LS, MW, MZ, NA, RW, SD, SL, SZ, TZ, UG, ZM, ZW), Eurasian (AM, AZ, BY, KG, KZ, RU, TJ, TM), European (AL, AT, BE, BG, CH, CY, CZ, DE, DK, EE, ES, FI, FR, GB, GR, HR, HU, IE, IS, IT, LT, LU, LV, MC, MK, MT, NL, NO, PL, PT, RO, RS, SE, SI, SK, SM, TR), OAPI (BF, BJ, CF, CG, CI, CM, GA, GN, GQ, GW, KM, ML, MR, NE, SN, TD, TG).

**Published:**

— with international search report (Art. 21(3))

[Continued on next page]

(54) Title: MICROWAVE OVEN AND METHOD FOR AUTOMATICALLY CONTROLLING THE HEATING AND/OR COOKING OF FOODS IN SAID MICROWAVE OVEN

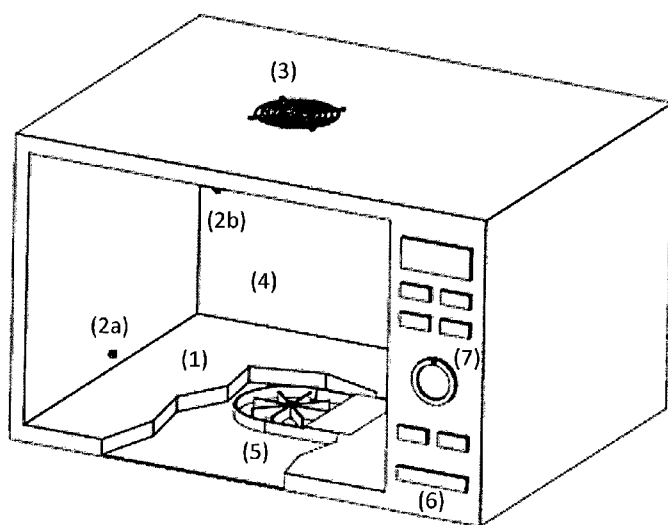

**Fig. 1**

(57) Abstract: The microwave oven comprises a magnetron for heating and/or cooking the food; a chamber (4) which allows arranging the food to be heated and/or cooked therein in a fixed manner and which has means (5) for distributing the electromagnetic waves therein; at least two thermal energy sensors (2a and 2b) arranged at different distances and with different angles from the food for detecting the temperature of said food; a control unit for managing the values acquired by said at least two thermal energy sensors (2a and 2b) and regulating the microwave oven operation when heating or cooking the food, wherein said magnetron is controlled by means of a control algorithm based on readings taken of said thermal energy sensors (2a and 2b).

- *before the expiration of the time limit for amending the claims and to be republished in the event of receipt of amendments (Rule 48.2(h))*

**Microwave oven and method for automatically controlling the heating and/or cooking of  
foods in said microwave oven**

**Field of the Art**

The present invention generally relates to a microwave oven and to a method in which  
5 the temperature of a food to be heated and/or cooked is monitored and controlled, and more  
particularly, in a first aspect, it relates to a microwave oven which allows automatically setting  
the time in which a magnetron of the microwave oven is injecting electromagnetic power until  
reaching a desired food temperature, as a result of a precise measurement of the food  
temperature depending on readings taken by different temperature sensors strategically  
10 arranged in the heating and/or cooking cavity of the microwave oven.

In a second aspect, the invention relates to a method implemented for automatically  
setting said operation time until the food reaches a specific temperature based on the food  
temperature measurements of said temperature sensors, enabling a simplified operation of the  
microwave oven in several specific operating modes, particularly: for heating to a specific  
15 temperature, for keeping food at a given temperature for a specific time period, for cooking at a  
low or medium temperature, for boiling for a predetermined time, etc., and also a simpler  
handling thereof by the user.

**Background of the Invention**

20 An automatic control for cooking in a microwave oven based on detecting the humidity  
in the cooking cavity of the oven is known from documents US-A- 5445009, US-A- 68759369, or  
EP-A -0697802. Said documents describe various methods, all of them intended for reducing or  
eliminating the effect of noise generated by the electromagnetic emission from the microwave  
oven itself in order to prevent distortions in the humidity readings taken by means of humidity  
25 sensors.

On the other hand, like the present invention, US-A- 5693247 discloses a microwave  
oven including a precise mechanism for cooking a food based on detecting the temperature of  
the food arranged on a rotary support and which temperature is monitored by means of at least  
two temperature sensors separated a different distance in relation to the area that will be  
30 occupied by the food. However, in the microwave oven proposed in US-A- 5693247, the  
temperature detection is performed by compensating the distance existing between the food  
and said sensors by means of using the answer of a second degree equation.

One drawback of the mentioned document is that due to the placement of the sensors  
in the upper portion of the cooking chamber and to the arrangement of the rotary tray, the

temperature sensors are not always focused on one and the same point so the readings obtained for the temperature of the foods will need more complex and less precise calculations. Furthermore, the arrangement of sensors proposed by US-A- 5693247 is severely affected by the emission of vapors and gases derived from the food, particularly its water content.

5 US-A- 2003047559 discloses a high frequency heating apparatus wherein capable of simultaneously heating different kinds of objects to appropriate temperatures. The temperature detection means of US-A- 2003047559 is of a multiple type comprising a combination of temperature detection means A and B 226a, 226b, each of them working both during the mounting table rotation heating and during the concentrated heating.

10 JP-A- 2004 044846 comprises a heating chamber 1 for storing a heated material A, a magnetron 6 for generating high frequency wave for heating the heated material A, two infrared sensors 13, 13a, both located in one side wall of the heating chamber for measuring surface temperature of the heated material A, in a non-contact state, a control part 11 for controlling the driving of the magnetron 6 based on a result detected by the infrared sensor 14,  
15 and a back cover 12 for covering a back part of the heating chamber 1 and disposed via a predetermined clearance for thermal insulation. A rotatable support 17 receives the food to be heated.

#### Description of the Invention

20 Therefore, there is a general interest in the field of microwave ovens to enable automatically controlling oven operation for a desired cooking and/or heating of different classes of foods (various foods and/or drinks) in said microwave oven, monitoring and controlling the temperature of the foods in a very efficient manner while they are being cooked and/or heated inside said microwave oven.

25 To that end according to a first aspect, the invention provides a microwave oven with an automatic control for controlling the temperature of a food to be heated and/or cooked, which conventionally comprises: a magnetron or electromagnetic energy generator for heating and/or cooking the food; a chamber for receiving the food to be heated and/or cooked therein; at least two thermal energy sensors arranged at different distances from the food in said chamber for  
30 measuring the temperature of said food; and a control unit for managing the values acquired by said at least two thermal energy sensors and regulating the microwave oven operation when heating or cooking the food.

In a characteristic manner, and unlike the solutions previously known in the state of the art, in the proposed microwave oven, said at least two thermal energy sensors are arranged

oriented with different angles for detecting the temperature of the lower and upper portions of the food; the food is arranged on a fixed supporting surface; the chamber of the oven has means for distributing the electromagnetic waves generated by said magnetron, and said magnetron is controlled by means of a control algorithm housed in said control unit which  
5 operates by taking a plurality of readings of said thermal energy sensors, measuring temperature values of the food in the two lower and upper portions a plurality of times, simultaneously with a predetermined electromagnetic energy supply state, said algorithm automatically regulating the electromagnetic energy supply depending on said temperature values measured by said at least two thermal energy sensors, the temperature and energy  
10 supply measurement ranges being variable during the time of heating and/or cooking the food in the microwave oven and depend on an objective temperature at which said food is to be heated and/or cooked.

In a characteristic manner, said predetermined energy supply state is zero or a value below a prefixed threshold suitable for preventing possible interferences which may be  
15 produced due to the electromagnetic waves or microwaves generated in said chamber with said thermal energy sensors.

According to one embodiment, the time variable electromagnetic energy supply can be carried out by means of generating micro-outages in said supplied electromagnetic energy, either at regular or non-regular intervals, the readings of the sensors being taken during said  
20 micro-outages, or alternatively, by means of an Inverter<sup>®</sup> power control system, which will allow reducing the supplied electromagnetic energy level below the prefixed threshold in one or several moments of cooking and/or heating, and in general varying the energy capacity supplied.

According to another embodiment, the thermal energy sensors are thermopile infrared  
25 sensors arranged such that they allow taking reliable and constant readings of the temperature of the food inside the microwave oven, and can thus interact with the magnetron power. In a preferred embodiment, these sensors are arranged in a side wall, positioned slightly above the food supporting plane, and in an upper wall of the chamber, inside or outside the chamber, and oriented such that they are pointing towards a central point of the supporting surface; readings  
30 of the most significant points of the food are thus allowed.

If said sensors are arranged outside the chamber, they will be accessed through one or more holes which will communicate the inside and the outside of the chamber. Said one or more holes will preferably have an opening such that interferences of said electromagnetic waves from said microwave oven with the sensor are prevented.

The proposed microwave oven further includes an extractor provided for extracting from the chamber water vapor or other possible gases which can be produced when cooking and/or heating said food. According to a preferred embodiment, said extractor will be provided with an extraction mouth spaced away from said at least two thermal energy sensors. On the other hand, the means used for distributing the electromagnetic waves also include a rotary reflector positioned below said food supporting plane.

According to an alternative embodiment, the microwave oven can also include a home automation module which allows monitoring and/or controlling the objective temperature from a user mobile computing device, for example, with a smartphone, a PDA, a tablet or a computer, etc., and it can further include a safety timer module to prevent overcooking and/or overheating said food.

In yet another alternative embodiment, the microwave oven can include one or several dedicated push buttons for accessing specific cooking and/or heating programs with electromagnetic energy supply control for at least the following processes: heating up to a prefixed temperature; keeping the temperature for cooking and/or heating the food at a prefixed temperature; cooking at a temperature kept below a prefixed threshold; or boiling a food for a prefixed time.

According to a second aspect, the invention provides a method for automatically controlling the temperature of a food to be cooked and/or heated in a microwave oven, which conventionally generates electromagnetic energy by means of a magnetron for heating and/or cooking a food placed inside a chamber within a microwave oven, wherein the electromagnetic waves generated by said magnetron are distributed, and wherein at least two thermal energy sensors are arranged in two different areas in said chamber for measuring the temperature of said food.

In a characteristic manner, the proposed method comprises arranging the food on a fixed supporting surface inside said chamber and orienting said at least two thermal energy sensors for detecting the temperature of the lower and upper portions of the food which, as has been indicated above, is fixed. Furthermore, the provided method controls the electromagnetic energy supply by controlling said magnetron by means of an algorithm which operates by taking a plurality of readings of said thermal energy sensors, measuring temperature values of the food in said two lower and upper portions a plurality of times, simultaneously with a predetermined electromagnetic energy supply state preventing interferences with said thermal energy sensors, said algorithm automatically regulating the electromagnetic energy supply depending on said temperature values measured by said at least two thermal energy sensors in

relation to an objective temperature of said cooking and/or heating and, the temperature and energy supply measurement time intervals being the same or variable during the time of heating and/or cooking the food in the microwave oven depending on said objective temperature at which said food is to be heated and/or cooked, such that amounts of electromagnetic energy adapted to the energy necessary for achieving said objective temperature are supplied in the same or different batches.

Finally and according to one embodiment, the time variable electromagnetic energy supply can be carried out either by means of generating micro-outages determining there between said batches of energy supply or in contrast, by means of an Inverter® power control system determining a reduction in the supplied electromagnetic energy below a prefixed level, said batches of energy supply being defined between two consecutive, reduced energy levels.

If said supply is generated by micro-outages, the operating cycles of the magnetron transformer are performed at a very high frequency to optimize cooking the foods in a uniform manner. These micro-outages will preferably be closer to one another in time the closer the food gets to the objective temperature to be achieved.

In addition to compensating for the temperature difference between the food to be heated and/or cooked (content) and the vessel (container) as a result of the continuous temperature detection by the two thermal energy sensors, the present invention will allow, due to the implementation of the mentioned control algorithm, providing a significant overall temperature value of the food which can then be shown to the user, for example, by means of a display.

#### Brief Description of the Drawings

The foregoing and other features and advantages will be better understood from the following detailed description of several embodiments in reference to the attached drawings in which:

Figure 1 is an illustration of the microwave oven proposed according to the first aspect of the invention.

Figures 2A, 2B and 2C are the illustrations of the evolution undergone by the electromagnetic energy generated by the magnetron controlled according to the method of this invention depending on the micro-outages or on the Inverter® power according to several embodiments.

#### Detailed Description of an Embodiment

In reference to Figure 1, said figure shows a microwave oven which comprises a food supporting surface formed, as is already known in the field, by a ceramic plate 1 which is porous to electromagnetic radiations or microwaves, a centrally arranged electromagnetic wave distribution system 5 (in the illustrated example, the system is made up of a rotor or turbine) to which the electromagnetic waves are driven by a waveguide guiding the waves generated by the magnetron (not illustrated, however, the magnetron is of a conventional type, i.e., an electromagnetic wave or microwave generator common in this field of the art and has a power suitable for the required performance) said rotor or turbine being located below the food, distributing the waves homogenously throughout the cavity 4 without the need of using the rotary plate, successfully distributing the generated electromagnetic waves or microwaves uniformly throughout the cavity 4 of the microwave oven and all through the food, temperature sensors 2a and 2b and a vapor extractor 3.

According to the first aspect of the invention, the supporting surface of the food is formed by the actual porous ceramic plate 1, i.e., the food remains fixed during cooking and/or heating.

The temperature sensors 2a and 2b provided are preferably thermopile type infrared sensors. These electronic devices convert thermal energy into electric energy by means of small thermocouples connected in series, being able to take readings of the surface temperature of the food to be heated and/or cooked without needing to be in contact. These sensors generate an output voltage of between 0 and 5V, and allow taking readings of between -20°C and 120°C. According to the proposal of this invention, said thermal energy sensors are always pointing strategically towards the same point of an area provided for locating the food or vessel, so one 2a will preferably be arranged in one of the side walls of the chamber 4 of the microwave oven, such that it is capable of measuring the temperature of the food in the lower plane slightly above the supporting area 1, and another sensor 2b will be arranged in one of the upper walls of the same chamber 4 for measuring the temperature in the upper plane of the food. Alternatively said sensors 2a and 2b could be centrally located in one and the same side wall at different heights, their different angular orientation and their positioning towards the area intended for receiving the food which, as has been indicated, is fixed, during the cooking and/or heating operation being important, thereby assuring uniformity when taking temperatures.

On the other hand, the vapor extractor 3 is arranged at a distance from the sensors 2a and 2b such that when the food is being heated, the possible water vapors or other gases that may be generated are quickly extracted from the chamber 4 of the oven such that they do not influence the measurement detected by the sensors 2a and 2b. In a preferred embodiment, this

vapor extractor 3 has an extraction mouth situated in the upper portion of the microwave oven, as can be observed in Figure 1. Nevertheless, in an alternative embodiment, the mentioned extractor could also be located in the opposite wall of the chamber 4 where the sensors 2a and 2b are arranged to assure an immediate separation of the vapor or moisture generated in relation to the area occupied by the sensors 2a and 2b, which sensors can thus take a "clean" reading of the surface temperature of the food on which these sensors are focused.

The control of the thermal energy sensors 2a and 2b and of the power supply of the magnetron will be performed by means of a microcontroller or a microprocessor. Particularly, a Microchip® PIC such as Microchip® PIC24FJ64GA006 could be used. This microcontroller will have the desired time and temperature as inputs, in addition to door open sensors/detectors and the mentioned thermopile sensors 2a and 2b. As outputs, it will have the control for lighting the chamber of the oven, the rotor or turbine 5 of the microwave oven and a transformer powering the magnetron. With the internal menu of the PIC, the invention allows determining the type of heating to be performed: quick, slow, progressive, increasing exponentially, decreasing exponentially, etc. The behavior of the magnetron once reaching desired food temperature can also be determined. This control will be performed with a configurable PID.

In a preferred embodiment, the control algorithm has been designed for gradually performing, for example, micro-outages in the electromagnetic energy generated by the magnetron depending on the actual temperature of the food at the time of taking the measurement and the objective temperature. As mentioned above, these micro-outages will generally be of a shorter duration closer to one another in time as the temperature of the food measured by means of the two thermal energy sensors 2a and 2b becomes closer to the objective temperature and will generally comprise, in a first sequence, outages of a very different duration.

In one embodiment, Figure 2A, the electromagnetic energy supply is controlled by means of generating micro-outages separating fragments of common maximum electromagnetic power (sectors of the same height) and the thermopile sensors 2a and 2b take the different temperature readings when the magnetron is not emitting electromagnetic power. In this particular case, depending on the reading of the temperature of the food (which, in a preferred example, is the mean of the two temperatures, a lower and a higher temperature, measured by the thermopiles 2a and 2b), electromagnetic waves will be injected at maximum power for a specific time (the invention proposes up to three possible different time durations), the closer the read temperature is to the objective temperature or *temp\_set*, the shorter these time periods will be.

In another embodiment, Figure 2B, the technology used for controlling the electromagnetic energy supply is an Inverter® technology but micro-outages are also performed to enable taking the reading of the thermopiles 2A and 2B and the duration of the micro-outages and the time which the magnetron is emitting electromagnetic power are fixed. In this particular case, the electromagnetic energy supplied to the food varies depending on the power level provided by the Inverter® technology, such that the closer the read temperature is to the objective temperature, the lower the power emitted by the magnetron is. In the drawing, a section in which energy is not injected until the detected temperature drops has been included in the area close to the objective temperature which has been surpassed and the energy supply to said objective temperature is thus completed.

In yet another embodiment, Figure 2C, the technology used for controlling the electromagnetic energy supply is Inverter® technology without the need of performing micro-outages to take the reading of the thermopiles 2A and 2B. In this particular case, when the electromagnetic power supplied to the food is less than the reading frequency, it is possible to take a series of readings continuously with the subsequent regulation of the supplied electromagnetic power using the same strategy proposed by the method of the invention.

On the other hand, the power emitted by the magnetron will be distributed in the on/off cycles. These cycles will be controlled by the PIC that will send the information corresponding to the high voltage transformer powering the magnetron.

In a possible embodiment, this proposed microwave oven has a capacity of 20 liters, a microwave power of 800W and a ceramic surface which is transparent to the electromagnetic waves emitted. It further generates maximum power pulses with a variable duration depending on the percentage of power which has been selected and which is to be applied to the food. In an alternative embodiment, it also has a new timer for controlling the cooking time and the objective temperature at which the food is to be cooked and/or heated.

Given that the method described based on the mentioned algorithm allows very precise cooking and/or heating, it has been provided in a preferred embodiment that the microwave oven has knobs or push buttons 7 located in the front panel 6 of the microwave oven allowing direct access to the intelligent cooking processes or programs. For example, directly heating the food at a prefixed temperature; keeping a food at a given temperature (input temperature or a desired preservation temperature); cooking at a low or medium temperature (e.g., cooking eggs or fish or in contrast, cooking a stew); boiling the food for a prefixed time (e.g., for infusions, pastas, etc.)

On the other hand, according to another alternative embodiment, the microwave oven

can also have a home automation module to monitor and/or control the objective temperature from a user mobile computing device and/or also a safety timer module to prevent overcooking or overheating said food.

The scope of this invention is defined in the following set of claims.

5

### Claims

1.- A microwave oven for automatically controlling the heating and/or cooking of foods which comprises:

- a magnetron for heating and/or cooking the food;
- 5 - a chamber (4) for receiving the food to be heated and/or cooked therein;
- at least two thermal energy sensors (2a and 2b) arranged at different distances from the food in said chamber (4) for measuring the temperature of said food; and
- a control unit for managing the values acquired by said at least two thermal energy sensors (2a and 2b) and regulating the microwave oven operation when heating  
10 and/or cooking the food,

characterized in that

- said at least two thermal energy sensors (2a and 2b) are arranged oriented with different angles for detecting the temperature of lower and upper portions of the food;
- 15 - a supporting surface (1), fixed and unmovable, holding the food;
- said chamber (4) of the microwave oven has means (5) for distributing the electromagnetic waves generated by said magnetron; and
- said magnetron is controlled by means of a control algorithm housed in said control unit, which operates by:
  - 20 ○ taking a plurality of readings of said thermal energy sensors (2a and 2b), and,
  - measuring, a plurality of times, temperature values of the food in said two lower and upper portions, each of said measuring taking place simultaneously with a predetermined electromagnetic energy supply state,
- 25 said algorithm automatically regulating the electromagnetic energy supply depending on said temperature values measured by said at least two thermal energy sensors (2a and 2b), and the temperature and energy supply measurement ranges being variable during the time of heating and/or cooking the food in the microwave oven and being a function of an objective temperature at which said food is to be heated and/or cooked.

30 2.- The oven according to claim 1, characterized in that said predetermined energy supply state is zero or a value below a prefixed threshold suitable for preventing interferences of the electromagnetic waves generated in said chamber (4) with said thermal energy sensors (2a and 2b).

3.- The microwave oven according to claim 1, characterized in that said time variable

electromagnetic energy supply is carried out by means of generating micro-outages in said supplied electromagnetic energy at regular or non-regular intervals, readings of the thermal energy sensors (2a and 2b) being taken during said micro-outages.

4.- The microwave oven according to claim 1, characterized in that said time variable  
5 electromagnetic energy supply is carried out by means of an Inverter® power control system, which allows varying the supplied electromagnetic energy level and reducing it below said prefixed threshold in one or several moments of heating and/or cooking.

5.- The microwave oven according to claim 1, characterized in that said at least two  
10 thermal energy sensors (2a and 2b) are arranged in a side wall, positioned slightly above the food supporting plane, and in an upper wall of said chamber (4), inside thereof, and oriented pointing towards a central point of the supporting surface (1).

6.- The microwave oven according to claim 1, characterized in that said at least two  
15 thermal energy sensors (2a and 2b) are arranged in a side wall, positioned slightly above the food supporting plane, and in an upper wall of said chamber (4), outside thereof, with an access through one or more holes, and oriented pointing towards a central point of the supporting surface (1).

7.- The microwave oven according to claim 5 or 6, characterized in that it further  
20 comprises an extractor device (3) for extracting from the chamber (4) water vapor or gases which are produced when heating and/or cooking said food, at least one extraction mouth being arranged spaced away from said at least two thermal energy sensors (2a and 2b).

8.- The microwave oven according to claim 1, characterized in that said means (5) for  
distributing the electromagnetic waves comprise a rotary reflector positioned below said food supporting plane.

9.- The microwave oven according to claim 1, characterized in that said thermal energy  
25 sensors (2a and 2b) are thermopile type infrared sensors.

10.- The microwave oven according to claim 1, characterized in that it further comprises  
a home automation module which allows monitoring and/or controlling the objective temperature from a user mobile computing device.

11.- The microwave oven according to claim 10, characterized in that it further  
30 comprises a safety timer module to prevent overcooking said food.

12.- The microwave oven according to any one of the preceding claims, characterized in  
that it comprises one or several dedicated push buttons (7) for accessing specific cooking and/or heating programs with electromagnetic energy supply control for at least the following processes:

- heating up to a prefixed temperature;
- keeping the food for a prefixed time at a prefixed temperature;
- defrosting;
- cooking at a temperature kept below a prefixed threshold;
- 5 - boiling a food for a prefixed time.

13.- A method for automatically controlling the heating and/or cooking of foods in a microwave oven, which comprises generating electromagnetic energy by means of a magnetron for heating and/or cooking a food placed inside a chamber within a microwave oven, wherein the electromagnetic waves generated by said magnetron are distributed and wherein at least  
10 two thermal energy sensors are arranged in two different areas in said chamber for measuring the temperature of said food, characterized in that it comprises

- arranging the food on a supporting surface, fixed and unmovable, inside said chamber;
- orienting said at least two thermal energy sensors for detecting the temperature of a lower and upper portions of the food; and
- 15 - controlling the electromagnetic energy supply by means of controlling said magnetron by means of an algorithm which operates by:
  - o taking a plurality of readings of said thermal energy sensors (2a and 2b), and,
  - o measuring, a plurality of times, temperature values of the food in said two  
20 lower and upper portions, each of said measuring taking place simultaneously with a predetermined electromagnetic energy supply state, preventing interferences with said thermal energy sensors,

said algorithm automatically regulating the electromagnetic energy supply depending on said temperature values measured by said at least two thermal energy sensors in relation to an objective temperature of said cooking and/or heating and, the temperature and energy supply  
25 measurement time intervals being the same or variable during the time of heating and/or cooking the food in the microwave oven being a function of said objective temperature at which said food is to be heated and/or cooked, such that amounts of electromagnetic energy adapted to the energy necessary for achieving said objective temperature are supplied in the same or  
30 different batches.

14.- The method according to claim 13, characterized in that it comprises carrying out said time variable electromagnetic energy supply by means of generating micro-outages determining there between said batches of energy supply.

15.- The method according to claim 13, characterized in that it comprises carrying out

said electromagnetic energy supply by means of an Inverter<sup>®</sup> power control system determining a variable power and a reduction in the supplied electromagnetic energy below a prefixed level, said batches of energy supply being defined between two consecutive, reduced energy levels.

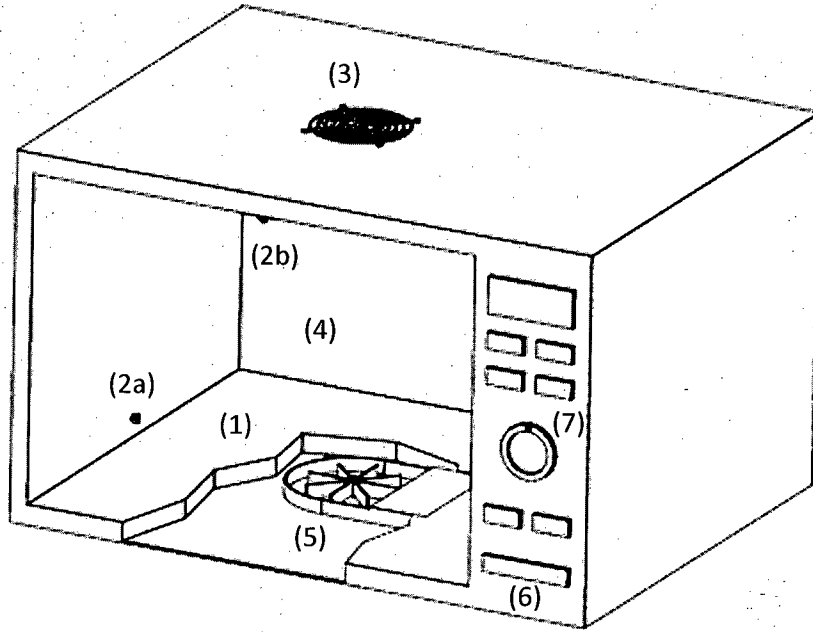

Fig. 1

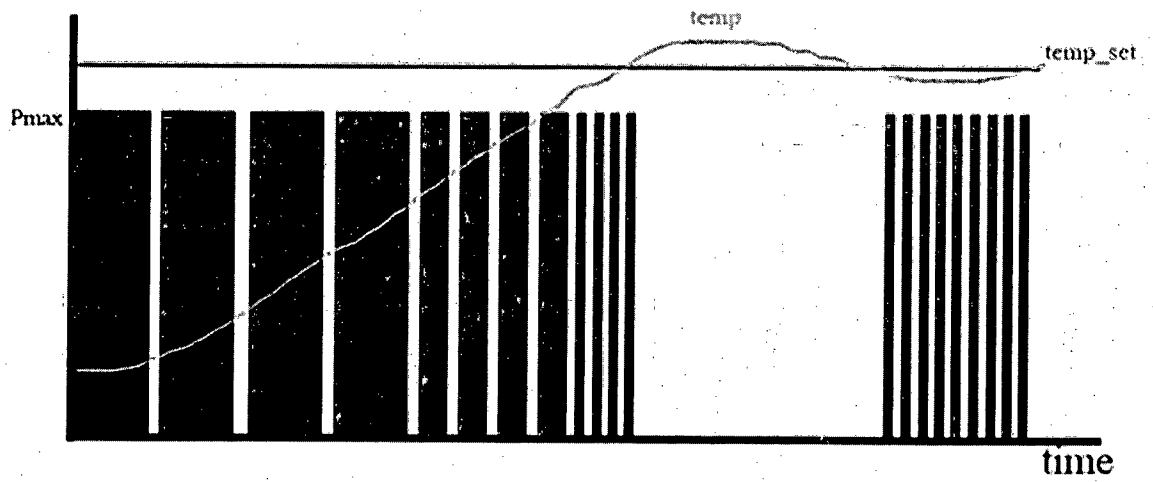

Fig. 2A

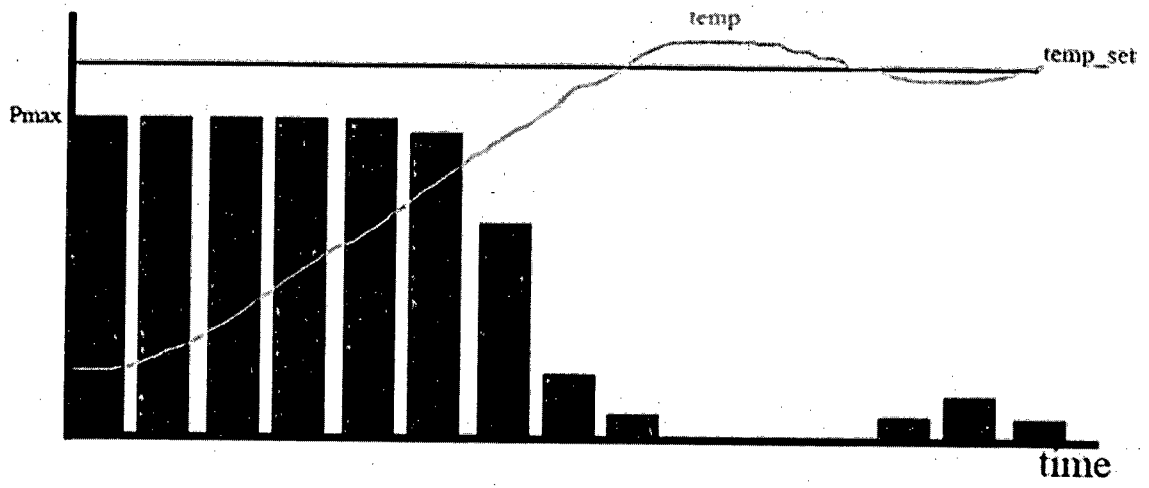

Fig. 2B

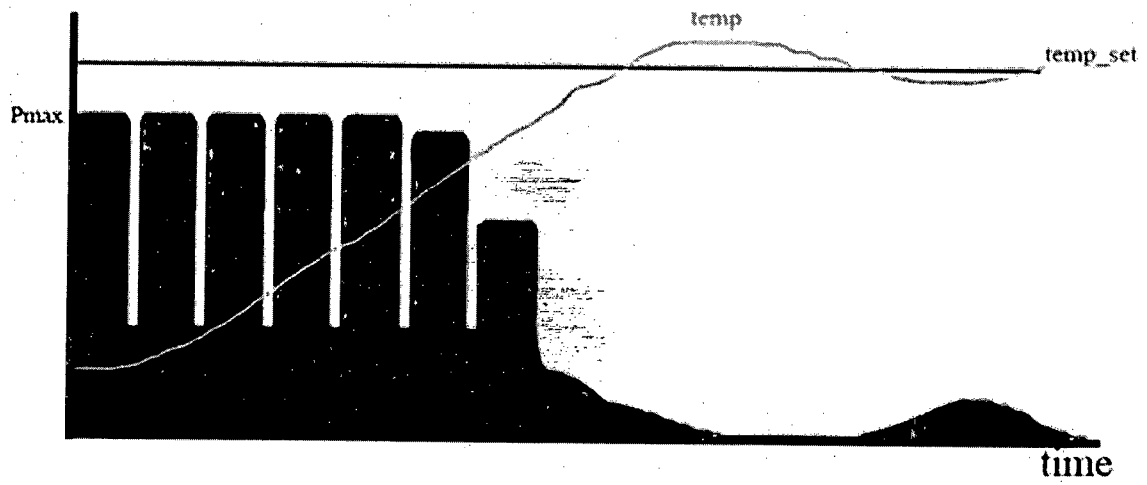

Fig. 2C

# INTERNATIONAL SEARCH REPORT

International application No PCT/IB2014/000224
---

<b>A. CLASSIFICATION OF SUBJECT MATTER</b> INV. H05B6/64 H05B6/68 ADD.		
According to International Patent Classification (IPC) or to both national classification and IPC		
<b>B. FIELDS SEARCHED</b>		
Minimum documentation searched (classification system followed by classification symbols) H05B		
Documentation searched other than minimum documentation to the extent that such documents are included in the fields searched		
Electronic data base consulted during the international search (name of data base and, where practicable, search terms used) EPO-Internal, WPI Data, PAJ		
<b>C. DOCUMENTS CONSIDERED TO BE RELEVANT</b>		
Category*	Citation of document, with indication, where appropriate, of the relevant passages	Relevant to claim No.
X	JP 2002 005450 A (MATSUSHITA ELECTRIC IND CO LTD) 9 January 2002 (2002-01-09) abstract; figure 20 -----	1, 13
X	JP 2004 044846 A (MITSUBISHI ELECTRIC CORP) 12 February 2004 (2004-02-12) abstract; figure 12 -----	1, 13
X	EP 1 150 549 A2 (SANYO ELECTRIC CO [JP]) 31 October 2001 (2001-10-31) paragraph [0052] - paragraph [0066]; figures 2,6 -----	1, 13
X	US 2003/047559 A1 (WATANABE KENJI [JP] ET AL) 13 March 2003 (2003-03-13) paragraph [0169] - paragraph [0173]; figure 20 -----	1, 13
----- -/--		
<input checked="" type="checkbox"/> Further documents are listed in the continuation of Box C.	<input checked="" type="checkbox"/> See patent family annex.	
* Special categories of cited documents :		
"A" document defining the general state of the art which is not considered to be of particular relevance	"T" later document published after the international filing date or priority date and not in conflict with the application but cited to understand the principle or theory underlying the invention	
"E" earlier application or patent but published on or after the international filing date	"X" document of particular relevance; the claimed invention cannot be considered novel or cannot be considered to involve an inventive step when the document is taken alone	
"L" document which may throw doubts on priority claim(s) or which is cited to establish the publication date of another citation or other special reason (as specified)	"Y" document of particular relevance; the claimed invention cannot be considered to involve an inventive step when the document is combined with one or more other such documents, such combination being obvious to a person skilled in the art	
"O" document referring to an oral disclosure, use, exhibition or other means	"&" document member of the same patent family	
"P" document published prior to the international filing date but later than the priority date claimed		
Date of the actual completion of the international search  23 June 2014	Date of mailing of the international search report  03/07/2014	
Name and mailing address of the ISA/ European Patent Office, P.B. 5818 Patentlaan 2 NL - 2280 HV Rijswijk Tel. (+31-70) 340-2040, Fax: (+31-70) 340-3016	Authorized officer  Gea Haupt, Martin	

# INTERNATIONAL SEARCH REPORT

International application No  
PCT/IB2014/000224

C(Continuation). DOCUMENTS CONSIDERED TO BE RELEVANT

Category*	Citation of document, with indication, where appropriate, of the relevant passages	Relevant to claim No.
X	US 5 693 247 A (BU JONG UK [KR] ET AL) 2 December 1997 (1997-12-02) cited in the application column 2, line 24 - line 39; figures 1,2 -----	1,13

# INTERNATIONAL SEARCH REPORT

Information on patent family members

International application No PCT/IB2014/000224
---

Patent document cited in search report	A	Publication date	Patent family member(s)	Publication date
JP 2002005450	A	09-01-2002	NONE	
-----				
JP 2004044846	A	12-02-2004	JP 3879042 B2	07-02-2007
			JP 2004044846 A	12-02-2004
-----				
EP 1150549	A2	31-10-2001	CN 1321854 A	14-11-2001
			EP 1150549 A2	31-10-2001
			JP 2002013743 A	18-01-2002
			US 2002005406 A1	17-01-2002
-----				
US 2003047559	A1	13-03-2003	CN 1366787 A	28-08-2002
			EP 1186209 A1	13-03-2002
			US 2003047559 A1	13-03-2003
			WO 0180602 A1	25-10-2001
-----				
US 5693247	A	02-12-1997	CN 1120148 A	10-04-1996
			JP 3232212 B2	26-11-2001
			JP H08159479 A	21-06-1996
			KR 0129239 B1	09-04-1998
			US 5693247 A	02-12-1997
-----				