

Jan. 12, 1943.

A. J. KORENYI

2,307,931

BLADE SHARPENING DEVICE

Filed June 2, 1942

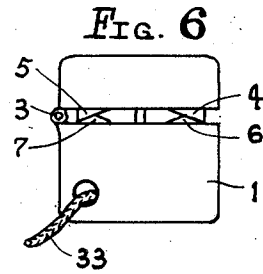
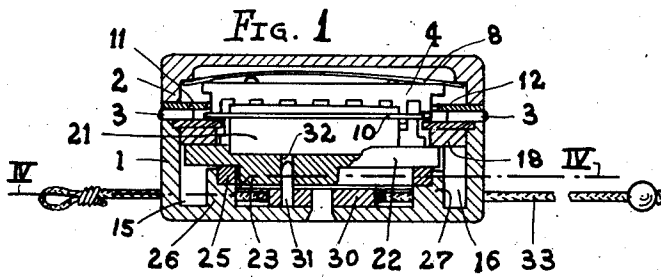

FIG. 2

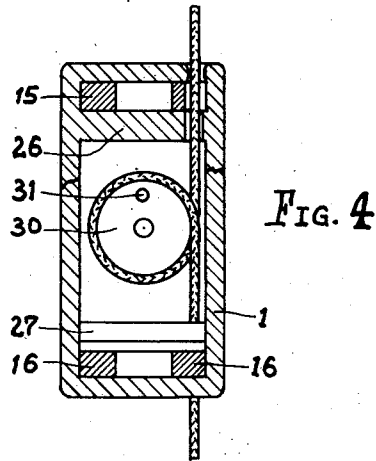
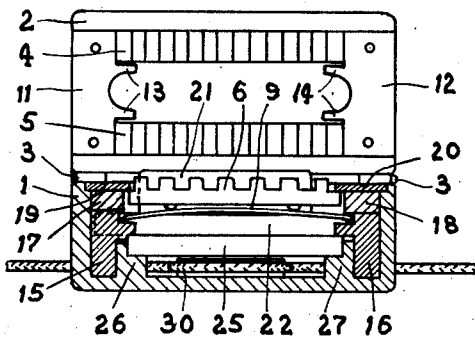

FIG. 3

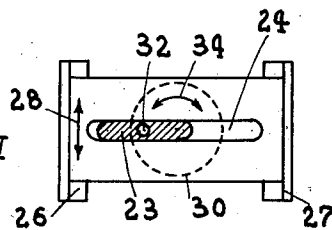
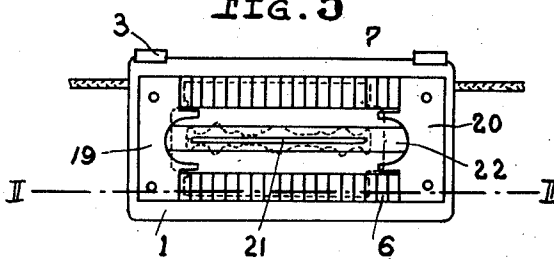

FIG. 5

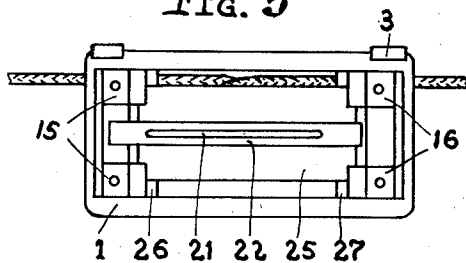

FIG. 7

INVENTOR.
ANDREW J. KORENYI
BY

Carl M. Avery

UNITED STATES PATENT OFFICE

2,307,931

BLADE SHARPENING DEVICE

Andrew J. Korenyi, New York, N. Y., assignor to
Blade Master, Incorporated, New York, N. Y., a
corporation of New York

Application June 2, 1942, Serial No. 445,415

6 Claims. (Cl. 51—161)

My invention relates to blade-sharpening devices, i. e., to apparatus for grinding or honing razor blades.

In a known type of blade sharpeners, a box-like casing is equipped with sharpening or grinding members, arranged at opposite sides of the blade to be sharpened and provided with springs for holding the members resiliently against the blade. A drive mechanism enclosed by the casing and operated by means of a cord serves to impart to the blade a rotating or otherwise non-linear motion while the cutting edge or edges of the blade are in contact with the grinding members. The cord extends exteriorly of the casing, and the device is actuated by moving it up and down along the suspended and tautened cord.

An object of my invention is to provide a blade-sharpening device which, while retaining substantially the operation of the above-mentioned known system as far as the sharpening is concerned, affords improvements and advantages with respect to the actuating mechanism of the apparatus. More particularly, an object of the invention is to provide an actuating mechanism whose individual operative elements, due to their particular motion and shape, are subjected to a minimum of mechanical stress so that their durability is improved or the requirement as to the strength of their material lessened. Referring to the latter aspect, an object of the invention is to afford the use of non-metallic materials, such as resinous and other artificial products, vitreous or mineral substances or wood, instead of the steel and other metal parts heretofore indispensable in this type apparatus, and it is also an object to achieve this result without substantial increase in the space requirements of the mechanism or the whole apparatus.

A further object of my invention consists in simplifying the driving elements proper of the blade-sharpening device, particularly with reference to a pulling cord mechanism of the aforementioned type, the intended simplification aiming at the elimination of one or more of the rollers heretofore necessary for transmitting the relative motion of the cord to the blade-impelling elements of the device.

It is also an object of the invention to provide a blade-sharpening device that lends itself readily to accommodating double edge or single edge blades of any design. That is, the invention aims at a construction whose mechanism is not inherently or practically limited to double edge blades, but in which the blade holder or blade impeller proper is easily adaptable for any kind of blades without change of the actuating mechanism.

According to the invention, a blade-sharpening device having grinding or honing members at both sides of the blade to be sharpened is designed as follows. The device contains a rotary drive

member provided with eccentric drive means. The drive means engage a blade holder to impart the sharpening movement thereto. A reciprocatory or shuttle member is disposed between the blade holder and the stationary frame structure or casing of the device so as to be limited to reciprocating straight line motions relative to the frame or casing. The shuttle member and the holder engage each other movably so as to limit the latter to relative motions at an angle to the motion of the shuttle member.

According to another feature of my invention, the blade holder, i. e., the element directly engaging the blade for impelling it relative to the honing or grinding members, consists of a single, preferably bar-shaped, part whose upper portion is shaped for engaging the blade and hence is adapted to the particular type of double edge or single edge blade to be accommodated. The lower portion of the holder engages both the shuttle member and the drive member. When speaking of a single part, I mean to say that only one moving element is used as a blade holder or impeller as contrasted with the two movable and separately actuated driving studs employed in a known construction. However, it is possible and advantageous to compose the blade holder according to my invention of several yet firmly and rigidly connected elements so as to form an integral structure. The holder effects no movement relative to the blade entrained thereby, and hence can easily be adapted to different blade types as mentioned in the foregoing.

The above-mentioned objects and features of my invention will be more fully understood from the following description of the embodiment exemplified by the drawing, all figures referring to the same apparatus.

Fig. 1 shows a longitudinal section through a box-like sharpening device according to the invention for double edge blades, the section extending substantially through the longitudinal axis of the device.

Fig. 2 shows the same device in a similar position yet with the cover opened and the base portion of the casing cut along the line II—II indicated in Fig. 3.

Fig. 3 shows a top view of the base portion of the casing with the cover portion removed.

Fig. 4 is a sectional top view of the same base portion, the section extending along the line IV—IV in Fig. 1.

Fig. 5 is also a top view of the base portion of the casing in a position similar to that of Fig. 3 but with several parts removed in order to show more clearly the blade holder and the shuttle member of the device.

Fig. 6 is a side elevation of the casing in closed condition.

Fig. 7 illustrates the shuttle member and its

guidance separately for elucidating the operation of the device.

Referring to the figures, 1 is the base portion and 2 the cover portion of a box-like casing of substantially prismatic shape serving as the frame structure of the device. Both parts are linked together by hinges 3. The cover portion forming the lid of the apparatus contains two sharpening members 4 and 5 (Figs. 1, 2 and 6) of abrasive or honing material. Two similar members 6 and 7 (Figs. 3 and 6) are arranged in the bottom portion 1. The members have saw-tooth-like projections carrying the sharpening surfaces proper so that each pair of juxtaposed sharpening members tends to have their teeth interleave each other when the lid is closed and no blade inserted. Leaf springs 8 and 9 (Figs. 1 and 2) are provided in the lid 2 and base portion 1, one for each sharpening member, to hold these members resiliently towards each other. The springs may consist of steel or other metal or of an elastic non-metallic material (for instance, bone springs). The sharpening surfaces of the members are oppositely inclined (Fig. 6) so that each pair forms a wedge-like assembly bearing against both sides of an inserted razor blade and forced more or less apart by the moving blade when in operation. This ensures a satisfactory sharpening operation acting simultaneously on both sides of the cutting edges of the blade.

If the apparatus is designed for single edge blades, only one pair of sharpening members, for instance 5 and 7, is necessary. The position of a double edge blade relative to the sharpening members, in the operative condition of the device, is apparent from Fig. 1, where the blade is denoted by 10, and from Fig. 3 showing the blade 10 by a broken contour line.

The sharpening members 4, 5 and springs 8 of the lid 2 are held in proper position relative to the lid by means of plates 11 and 12 (Figs. 1 and 2) so shaped as to permit and limit the up and down movements of the members while preventing, by means of projections 13 and 14, a lateral escape of the members. Similarly, the springs 9 and sharpening members 6 and 7 of the base portion 1 are held in proper position and guided by parts 15 and 16, 17 and 18, and plates 19 and 20 (Figs. 1, 2, 3, 4 and 5), the plates 19 and 20 having a shape and function similar to the plates 11 and 12 of the lid. The springs 9 rest on projections of the parts 15 and 16 (Fig. 2). The just-mentioned parts 15 through 18 of the base portion 1 serve also as guiding and stop members of the actuating mechanism, as will be set forth presently.

The blade-impelling member of the apparatus, here simply called a "holder," consists of a bar-shaped structure whose upper portion 21 (Figs. 1, 2, 3, and 5) projects upwardly beyond the sharpening surfaces of the lower sharpening members 7 and 8 (Figs. 1 and 2) so as to engage the central slot of the customary double edge blades (Figs. 1 and 3). The lower portion 22 of the blade holder (Figs. 1, 2, 3, and 5) extends sidewise (longitudinally) beyond the upper portion 21 and has a downward projection 23 (Figs. 1 and 7). This projection engages a slot 24 of a shuttle member formed of a rectangular plate 25 (Figs. 1, 2, 5, and 7). The shuttle plate rest on guides 26 and 27 which limit the motion of the plate to reciprocations in parallel to the short axis of the casing as is indicated in Fig. 7 by the arrow 28. The blade holder, due to the engagement of its portion 23 with the slot 24, is limited to reciproca-

tions relative to the plate 25 in a direction at right angles to the transversal plate motion, as is indicated in Fig. 7 by the arrow 29. The above-mentioned projections of parts 15 and 16 secure the plate 25 in proper position relative to its guides 26 and 27 (Figs. 2 and 5).

Underneath the plate 25 is a rotary drive member in the form of a friction roller 30. This roller is coupled with the lower portion 23 of the blade holder by eccentric drive means consisting of a drive stud 31 firmly mounted on roller 30 and engaging a bore 32 of the blade holder (Figs. 1, 4, and 7). An actuating cord 33 is passed through bores in the base portion 1 of the casing and arranged with respect to roller 30 so as to engage substantially the entire periphery of the roller. That is, the cord forms at least about one full turn. The shuttle guides 26 and 27 and the shuttle plate 25 limit the cord space within the casing and hence hold the cord in suitable relation to the roller. As a result, a sufficient friction between roller and cord is ensured without necessity of additional rollers or the like movable guide elements.

When using the device, the casing is opened and a blade placed over the upper end of the holder portion 21 so as to assume the position shown by broken lines in Fig. 3. Then the casing is closed, thereby placing the blade between the wedge-like sets of sharpening members which now are pressed by their springs against the cutting edges to be sharpened. The cord is suspended at one end from a hook, nail or the like, and kept fairly taut by holding its other end. When now the closed casing is moved up and down the cord, the roller 30 is rotated as indicated by the arrow 34 in Fig. 7. The rotation is imparted to the blade holder but, within the mechanism of the device, is resolved into the two rectilinear components represented by the arrows 28 and 29 in Fig. 7. Hence only the driving roller and its eccentric stud perform a rotary motion while the engagements between holder and shuttle, and between shuttle and casing, involve straight-line movements along rather extensive planes of contact.

As a result, the stresses are transmitted within the mechanism in a favorable way and over relatively large contact areas so that the specific stress on the material is extremely small. Since the motion of the shuttle member extends merely within its own plane, and that of the holder is parallel to this plane, these motion-transmitting elements require very little height even if they are constructed with relatively large wall thickness. By virtue of these characteristics of the mechanism, an increased strength and sturdiness of the device elements is obtained as compared with known sharpeners and under similar conditions as regards the materials employed. By the same token, however, the invention makes it possible to successfully use materials of lesser strength than heretofore required in such apparatus. For instance, resinous or other molded materials, vitreous or ceramic substances or wood can be used to advantage. Thus, a device constructed as shown and having all illustrated elements made of non-metallic materials has proved satisfactory, a result especially advantageous in times of emergency, as existing at the filing of this application, and not obtainable with the known sharpener mechanism without an undue increase of the over-all dimensions. The parts of a mechanism according to the invention have simple shapes, and hence can easily

be produced of the materials just mentioned. When using non-metallic materials in a sharpener for double edge blades, I prefer making the upper portion of the blade holder of vitric or ceramic substance, such as glass, in order to prevent it from being injured by the edges of the inner slot of the blades. Some or all of the stationary holding and guiding parts may consist of separate elements, or they may be connected or integrated with one another or with the respective portion of the casing.

While I have mentioned certain materials, it will be understood from the foregoing that the essential advantages of the invention are not predicated upon the use of any particular material. It will likewise be seen that various modifications as to details may be applied without leaving the scope of the essential features of the invention. For instance, the shuttle plate may be given a shape or provided with guiding means different from those illustrated while maintaining the essential resolution of the rotary drive motion into the two relative reciprocations of the shuttle and the blade holder.

I claim:

1. A blade-sharpening device, comprising a casing, blade-sharpening means in said casing for resiliently engaging a blade, a rotatable drive member journaled in said casing and having eccentric drive means, a shuttle plate disposed in said casing so as to be capable of constrained reciprocatory motion relative to said casing, said shuttle having a slot extending at a right angle relative to the direction of said motion, a blade holder for impelling a blade relative to said sharpening means, said holder being movable relative to said plate and extending into said slot in order to be guided thereby in the direction of said slot, the said eccentric drive means and the portion of said holder engaging said slot being coupled with each other, whereby said drive member when actuated imparts simultaneously reciprocatory motions at right angles to said plate and said holder respectively.

2. A blade-sharpening device, comprising a casing of elongated shape, blade-sharpening means resiliently disposed in said casing, a rotatable drive member journaled in said casing and having eccentric drive means, a movable shuttle plate, guide means in said casing for limiting the motion of said plate to reciprocations transverse to the main geometrical axis of said elongated casing, a movable blade holder arranged in said casing for impelling a blade while the latter engages said sharpening means, said plate forming a guide for said holder to limit the motion of the latter relative to said plate to reciprocations at right angles to said plate motion, said drive means engaging said holder, and exterior actuating means connected with said drive member for causing the latter to simultaneously reciprocate said plate and said holder relatively to said casing and said plate respectively.

3. A blade-sharpening device, comprising a casing having a bottom and a cover portion, blade-sharpening means disposed both in said bottom and cover portions for simultaneously engaging the two sides of a blade, spring means associated with said sharpening means for securing a resilient contact of the latter with a blade when said casing is in closed condition, a rotatable drive member journaled in said bottom portion and having eccentric drive means, a movable shuttle plate having a rectilinearly extend-

ing guide slot, stationary guide means in said casing for limiting the motion of said plate to reciprocations at right angles to the extension of said slot, a movable blade holder for impelling a blade, said holder having a portion engaging said slot so as to be limited to reciprocations along said slot and having said portion coupled with said drive means, whereby said holder is caused by said drive member, when actuated, to perform rotary motions relative to said casing while reciprocating in said slot and causing said plate to reciprocate at right angles thereto.

4. A blade-sharpening device, comprising a frame structure, sharpening means mounted on said structure for sharpening a blade, a drive member rotatably mounted on said structure, actuating means for imparting rotary motion to said member, a shuttle member movably disposed on said structure, said structure having guide means engaged by said shuttle member for limiting the motion of said shuttle member to straight-line reciprocations relative to said structure, a holder disposed in said frame structure for accommodating a blade so as to hold it in engagement with said sharpening means, said holder engaging said shuttle member so as to be reciprocable relative to the latter at an angle to said shuttle motion, said actuating means including an eccentric means engaging said holder so as to impart relative reciprocatory motions to said shuttle member and said holder, respectively, when said actuating means are operated, whereby the blade is moved relatively to said sharpening means.

5. A blade-sharpening device, comprising a supporting structure, blade-sharpening means mounted on said structure, a rotatable drive member having eccentric drive means, a shuttle member movably arranged in said structure, said structure having guide means engaging said shuttle member so as to limit its motion relative to said structure to rectilinear reciprocations, a holder movably arranged in said structure for holding a blade in contact with said sharpening means, said holder and said shuttle member engaging each other so as to form a parallel motion guide in order to constrain the motion of said holder relative to said shuttle to rectilinear reciprocations at right angles to said shuttle motion, said eccentric means engaging said holder so as to impart simultaneous relative reciprocating motions to said holder and said shuttle member respectively resulting in a rotary sharpening movement of the blade.

6. A blade-sharpening device, comprising a casing of substantially prismatic shape, blade-sharpening means resiliently disposed in said casing, a rotatable drive member disposed in said casing and having eccentric drive means, a shuttle plate movably disposed in said casing, guide means associated with said casing for constraining the motion of said shuttle plate relative to said casing so that the shuttle motion is limited to reciprocations in parallel to a geometrical axis of said casing, a blade holder movably disposed in said casing for impelling a blade while the latter is in contact with said sharpening means, said blade holder and said shuttle plate engaging each other so as to form a parallel motion guide for limiting the motion of said holder relative to said shuttle plate to reciprocations at right angles to that of said shuttle, and said eccentric drive means being coupled to said holder to impart simultaneously relative reciprocating motions to said holder and shuttle respectively.

ANDREW J. KORENYI,