

C. F. OESTERREICHER.
 FAN.
 APPLICATION FILED JAN. 5, 1911.

997,082.

Patented July 4, 1911.

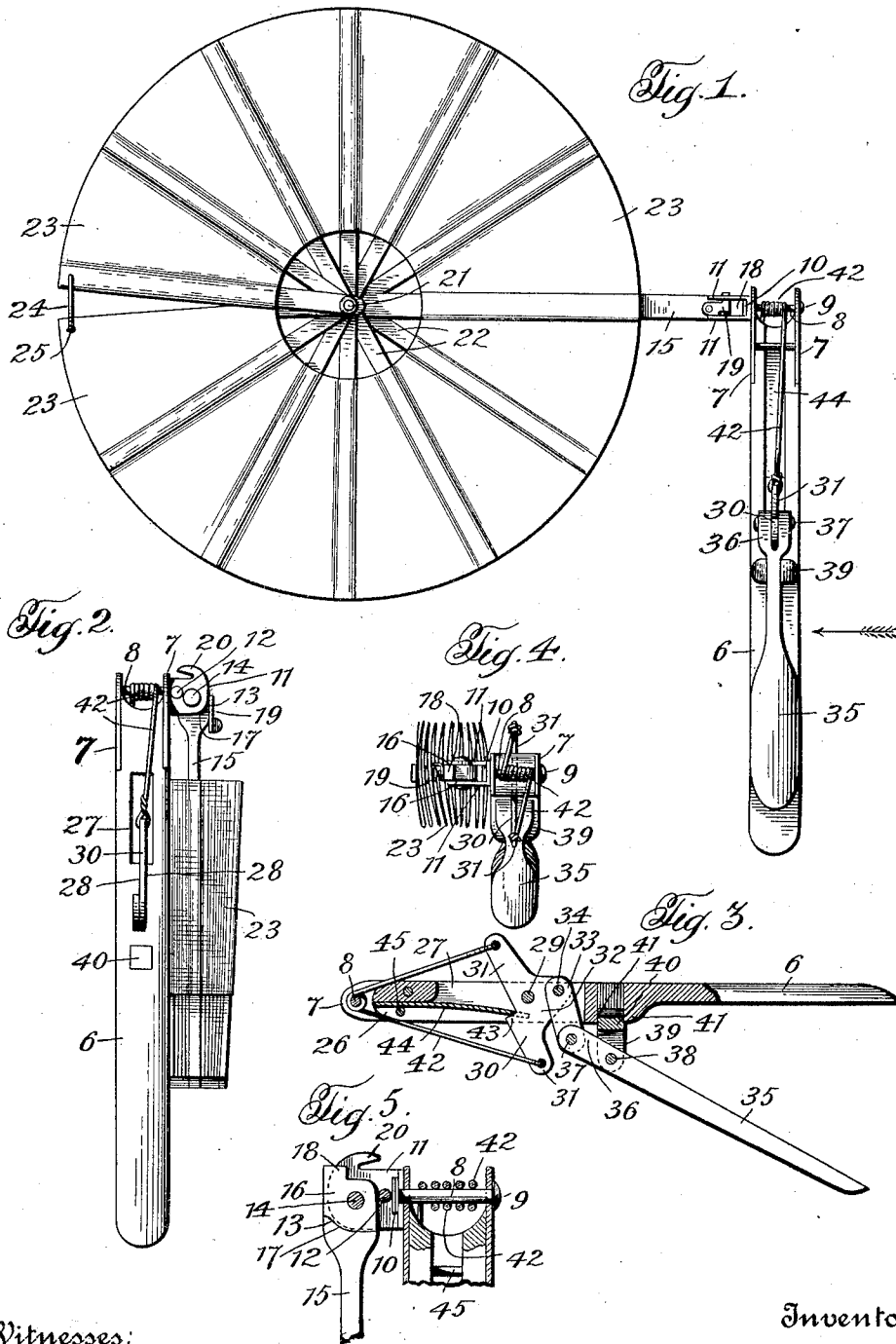

Witnesses:

Jas. Hutchinson
Carrie A. Krey

Inventor:

Clarence F. Oesterreicher,
 By *H. Ralph Borton,* Attorney:

UNITED STATES PATENT OFFICE.

CLARENCE F. OESTERREICHER, OF DURBIN, FLORIDA.

FAN.

997,082.

Specification of Letters Patent.

Patented July 4, 1911.

Application filed January 5, 1911. Serial No. 600,950.

To all whom it may concern:

Be it known that I, CLARENCE F. OESTERREICHER, a citizen of the United States, residing at Durbin, in the county of St. John and State of Florida, have invented certain new and useful Improvements in Fans, of which the following is a specification.

This invention relates to that class of fans which has a leaf or blade which is rotatable by manipulation of a portion attached to the handle, and it contemplates an article of this character which is simple in construction, positive in operation, and the leaf or blade of which is foldable on its carrying-arm and the arm foldable against the handle, whereby the article can be reduced to a compact form suitable to be carried in the pocket.

When read in connection with the description herein, the details of construction and arrangement of parts provided by the invention will be apparent from the accompanying drawings, forming part hereof, wherein an embodiment of the invention is disclosed, for purposes of illustration.

While the embodiment of the invention shown in the drawings is preferred, as it has given satisfactory and reliable results in practice, it is to be understood that the several instrumentalities of which the invention consists can be variously organized, without departing in the least from the nature and spirit of the invention, and that the invention is not necessarily to be limited to the precise delineation herein in interpretation of claims hereinafter.

Like reference-characters refer to corresponding parts in the several views of the drawings, of which—

Figure 1 is a side view, the fan being open and ready for use; Fig. 2 is a view of the other side, the fan being folded and certain parts broken away; Fig. 3 is a sectional view of the handle and its associated parts, looking in direction of the arrow, Fig. 1; Fig. 4 is a top view, the fan being folded; and Fig. 5 is a sectional view.

Having more particular reference to the drawings, 6 designates a handle, on opposite sides of which are secured, and from one end of which project, arms 7.

A shaft 8 is journaled in the ends of arms 7, in a line transverse of the handle. The shaft is held against longitudinal displacement from the arms in one direction by a head 9 on one end of the shaft outside of one

of the arms, and in the other direction by a squared head 10 on the other end of the shaft outside of the other arm. Between the head 10 and the outer surface of the arm on that side the shaft passes through the connecting portion of a substantially U-shaped member having complementary legs 11, and opposite edges of the squared head engage the inner sides of these legs, whereby the member is prevented from turning with respect to the shaft. A rivet or bolt 12 is firmly held in the legs and against the outer surface of the head to hold the head firmly against the connecting portion of the U-shaped member.

The outer or terminal edges of the legs 11 are rounded, as shown at 13, and at the radial center of these edges a bolt or the like 14 is held in the legs. A fan-blade-carrying arm 15 is pivoted on this bolt between the legs. The arm 15 has an enlarged end with flattened surfaces 16 which contact with the inner surfaces of the legs 11, and also shoulders 17 which contact with the rounded edges 13, whereby the arm is held firmly against any movement with respect to the legs other than turning movement on the bolt 14. It will be seen that when the fan is to be folded the arm 15 is turned on bolt 14 down against the handle, as shown in Fig. 2. When the fan is to be opened for use, the arm 15 is swung from the handle until it is at right angles to the handle and in line with shaft 8, at which position a shoulder 18 on the inner end of the arm will contact with the connecting portion of the substantially U-shaped member to prevent further turning movement in that direction. The arm is held in extended position by a pivoted catch 19 on the arm being turned under a hook or lug 20 on one of the legs 11.

On the outer end of arm 15 is a pin 21, on which are journaled radially-extending strips 22, to which is attached and to the arm 15 fabric 23 forming the surface of the fan-blade. The fabric is creased in the usual manner, so that the strips may be turned against the arm 15 to fold the blade and swung around from the arm to open the blade. On one of the two strips which meet when the blade is open is a catch 24, which is engageable in an aperture or seat 25 on the other of the two strips to hold the blade open.

The handle is formed with a slot 26 ex-

tending from the end carrying the arms 7 to an opening 27. This opening is contracted in its lower portion to form shoulders 28, between which is pivoted, on a pin 29 extending through the handle, a rocking member 30. This member has laterally-extending arms 31, and an arm 32 depending below the pivot. A link 33 is pivotally connected to the end of arm 32 by a rivet 34 and to the upper end of an operating-lever 35, the link being journaled between bifurcated ends 36 of the lever on a pin 37. The lever is pivoted, on a pin 38, between the bifurcated ends 39 of a bracket 40 mortised into the handle and between shoulders 41 on the handle, and it is capable of being swung toward and from the handle. A strap, cord, or other suitable flexible element 42 is wound on shaft 8 and has its ends connected to the ends of arms 31 of the pivoted member 30. The member 30 has, in its top edge, which is above the pivot 29, and intermediate the ends of arms 31, a notch or seat 43, with which is engaged the lower end of a leaf-spring 44. The upper portion of this spring is seated in the slot 26 and firmly held therein by a pin 45. The spring possesses a tendency to force its lower end outwardly and thereby to draw the end of the arm 32 in the opposite direction and the upper end of the lever 35 toward the handle, which movement will obviously move the lower end of the lever away from the handle.

When it is desired to operate the fan, the handle and operating-lever are grasped by the hand and the lower portion of the lever drawn toward the handle. This will rock member 30 on its pivot, through the instrumentality of link 35, against the tendency of movement of spring 44, and cause the flexible element wound on the shaft 8 to be drawn in one direction and the shaft and arm 15 with its fan-blade rotated in one direction. Upon release of pressure on the operating-lever, the spring 44 will operate to rock the member 30 in the other direction and cause reverse rotating movement of the

fan-blade. The successive pressure on and release of the operating-lever will cause successive rotating movements of the fan-blade and the movement of the atmosphere desired by the user.

Having thus described my invention, what I claim as new, and desire to secure by Letters Patent, is—

1. A fan comprising a handle, a shaft journaled thereon, a fan-blade-carrying arm pivoted on said shaft and foldable against said handle, and means whereby said shaft is rotated.

2. A fan comprising a handle, a shaft journaled thereon, a substantially U-shaped member on said shaft, a fan-blade-carrying arm pivoted between the legs of said member and foldable against said handle, and means whereby said shaft is rotated.

3. A fan comprising a handle, a shaft journaled thereon, a substantially U-shaped member on said shaft, a fan-blade-carrying arm pivoted between the legs of said member and foldable against said handle and capable of being extended to operative position in line with said shaft, means to stop extending movement when said arm has reached position in line with said shaft, means to retain said arm in extended position, and means whereby said shaft is rotated.

4. A fan comprising a handle, a shaft journaled thereon, a fan-blade-carrying arm pivoted on said shaft and foldable against said handle and capable of being extended to operative position in line with said shaft, a stop to arrest extending movement when said arm has reached position in line with said shaft, a lug, and a catch engageable with said lug to retain said arm in extended position, and means whereby said shaft is rotated.

In testimony whereof I affix my signature in presence of two witnesses.

CLARENCE F. OESTERREICHER.

Witnesses:

C. W. WING,
T. E. POPE.