



(43) International Publication Date
6 August 2015 (06.08.2015)

- (51) International Patent Classification:
A61M 39/10 (2006.01) A61M 39/20 (2006.01)
- (21) International Application Number:
PCT/IB2014/067444
- (22) International Filing Date:
31 December 2014 (31.12.2014)
- (25) Filing Language: Italian
- (26) Publication Language: English
- (30) Priority Data:
TO2014A000078 31 January 2014 (31.01.2014) IT
- (71) Applicant: **INDUSTRIE BORLA S.P.A.** [IT/IT]; Via G. Di Vittorio, 7bis, I-10024 Moncalieri (Torino) (IT).
- (72) Inventor: **GUALA, Gianni**; Strada Villa Zanetti, 28/18, I-10133 Torino (IT).
- (74) Agent: **BUZZI, Franco**; Buzzi, Notaro & Antonielli d'Oulx S.r.l., Via Maria Vittoria, 18, I-10123 Torino (IT).
- (81) Designated States (unless otherwise indicated, for every kind of national protection available): AE, AG, AL, AM,

AO, AT, AU, AZ, BA, BB, BG, BH, BN, BR, BW, BY, BZ, CA, CH, CL, CN, CO, CR, CU, CZ, DE, DK, DM, DO, DZ, EC, EE, EG, ES, FI, GB, GD, GE, GH, GM, GT, HN, HR, HU, ID, IL, IN, IR, IS, JP, KE, KG, KN, KP, KR, KZ, LA, LC, LK, LR, LS, LU, LY, MA, MD, ME, MG, MK, MN, MW, MX, MY, MZ, NA, NG, NI, NO, NZ, OM, PA, PE, PG, PH, PL, PT, QA, RO, RS, RU, RW, SA, SC, SD, SE, SG, SK, SL, SM, ST, SV, SY, TH, TJ, TM, TN, TR, TT, TZ, UA, UG, US, UZ, VC, VN, ZA, ZM, ZW.

(84) Designated States (unless otherwise indicated, for every kind of regional protection available): ARIPO (BW, GH, GM, KE, LR, LS, MW, MZ, NA, RW, SD, SL, ST, SZ, TZ, UG, ZM, ZW), Eurasian (AM, AZ, BY, KG, KZ, RU, TJ, TM), European (AL, AT, BE, BG, CH, CY, CZ, DE, DK, EE, ES, FI, FR, GB, GR, HR, HU, IE, IS, IT, LT, LU, LV, MC, MK, MT, NL, NO, PL, PT, RO, RS, SE, SI, SK, SM, TR), OAPI (BF, BJ, CF, CG, CI, CM, GA, GN, GQ, GW, KM, ML, MR, NE, SN, TD, TG).

Published:
— with international search report (Art. 21(3))

(54) Title: VALVED CONNECTOR FOR MEDICAL LINES

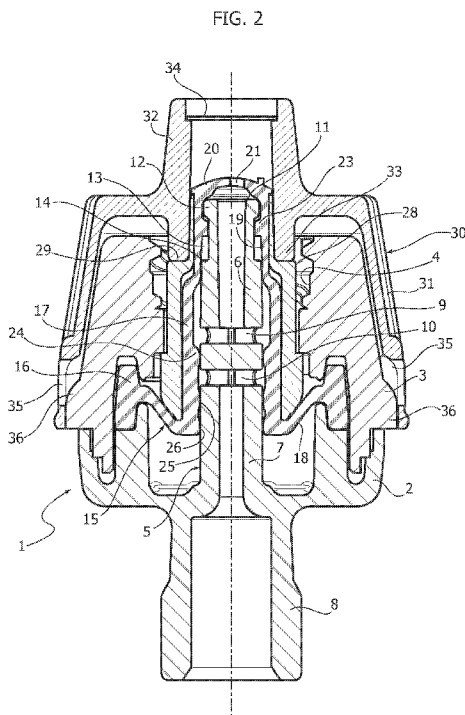

(57) Abstract: A valved male luer connector including an elastic hollow element (15) which encloses a tubular member (5) having an inlet portion (7) and an outlet portion (6). A collar (28) is axially displaceable causing a stretching deformation of the elastic hollow element (15) and opening the flow passage between the inlet portion (7) and the outlet portion (6) of the tubular member (5). A priming cap (30) is designed to be releasably connected to the casing (1) of the valved connector to provide stretching deformation of the elastic element (15) and keep the outlet portion (6) of the tubular member (5) in communication with the atmosphere through a liquid-impermeable barrier (34).

- 1 -

"Valved connector for medical lines"

Field of the invention

The present invention relates in general to
5 connectors for medical fluids, and particularly
concerns a valved male luer connector connectable to a
fluid line and designed to be connected to a connector
generally of the female luer type and the like to open
the flow passage of the fluid through the two
10 connectors.

State of the prior art

From the patent US-7559530, as well as the
European patent application EP-2504056 (WO-
2011/064738), both owned by the Applicant, a valved
15 male luer connector is disclosed, comprising a casing,
a tubular member having an inlet portion and an outlet
portion with an open terminal end, and an elastic
hollow element secured to the casing and enclosing the
tubular member. The elastic hollow element has a
20 terminal wall, which normally seals closed the terminal
end of the outlet portion of the tubular member and has
a cut. A collar interposed between the casing and the
elastic hollow element is axially displaceable,
following thrust engagement by a female connector
25 connectable to the male connector, causing a stretching
deformation of the elastic hollow element elastic and
consequent opening of the flow passage between the
inlet portion and the outlet portion of the tubular
member.

30 This valved male luer connector thus operates
according to the stretching deformation of the elastic
hollow element: in this way, it can guarantee a perfect
closure in the absence of the female connector, a
prompt opening during coupling with the female
35 connector, and a rapid return to the closed condition

- 2 -

following decoupling of the female connector.

In the case where the tubular member is connected to a supply line of a medical liquid contained, for example, in a bag, it is necessary to carry out
5 "priming" of the line beforehand, or rather before the connection of the female connector for transferring the medical liquid to a patient. Therefore, the operator must manually open the valved connector until the medical liquid coming from the line reaches the
10 terminal end of the tubular member. This operation is delicate and can be complicated and inconvenient.

From the documents US-5032116A and WO-2004/014477, medical devices provided with a removable ventilation cap are known.

15 Summary of the invention

The object of the present invention is to resolve the aforesaid problem in a simple, practical and functional manner and in a manner to avoid losses of liquid.

20 According to the invention, this object is achieved thanks to a valved male luer connector of the type defined at the beginning, and corresponding to the preamble of claim 1, whose unique characteristic lies in the fact that it includes a priming cap, designed to
25 be releasably connected to the connector casing for stretching deformation of said elastic element, and to keep said terminal end of the outlet portion of the tubular member in communication with the atmosphere by means of a liquid-impermeable membrane. The priming cap
30 comprises a skirt arranged on the outside of the casing and configured to engage the connector casing and a tubular part coaxial to the skirt, which on one side carries the aforesaid liquid-impermeable barrier and on the opposite side it is arranged to interact with the
35 collar interposed between the casing and the elastic

- 3 -

hollow element.

The skirt of the priming cap is selectively engageable with said casing, in a first axial position to protect the end wall of the elastic hollow element, in which this elastic hollow element is essentially undeformed, and in a second axial position in which said elastic hollow element is stretched.

In the second axial position, the skirt of the priming cap is conveniently connected to the casing of the connector by means of a bayonet coupling.

Thanks to this solution idea, the valved male luer lock connector according to the invention enables, during use, the immediate connection to the female connector without the need of firstly having to perform priming of the supply line of the medical liquid, since the priming is made ready and available by the presence of the cap applied in a removable manner to the body of the connector, without the risk of liquid loss, when it is arranged in the aforesaid second axial position. The connection of the valved male luer lock connector to the female connector can therefore be carried out directly, following removal of the priming cap, the effect of which returns the elastic element to the undeformed closed condition of the connector, which will then be reopened due to the effect of coupling with the female connector.

Brief description of the drawings

Further characteristics and advantages of the invention will become apparent from the detailed description which follows, with reference to the attached drawings provided purely by way of non-limiting example, in which:

Figure 1 is a schematic perspective view of the valved male luer connector according to the invention,

Figure 2 is a view in axial cross-section of the

- 4 -

valved connector in a first condition,

Figures 3 and 4 are two perspective views, frontal and dorsal, respectively, of the priming cap of the valved connector according to the invention, and

5 Figure 5 is an analogous view to Figure 2, which shows the valved connector in a second condition.

Detailed description of the invention

Referring to the drawings, the valved male luer connector according to the invention comprises (in a generally known manner from the aforementioned documents US-7559530 and EP-2504056), a casing 1 formed of a lower flange portion 2, permanently coupled to an upper hollow body 3 formed, at the opposite side to the flange 2, of an internally threaded seat 4.

15 The flange 2 is, in turn, formed integrally and coaxially with a tubular member indicated as a whole by 5, having an inlet portion 7 and an outlet portion 6, which extends through the hollow body 3 and projects outwards from the relative threaded seat 4. The outlet portion 6, together with other parts that will be described below, defines with the threaded seat 4, a male luer lock connector suitable for engagement with a female connector, not illustrated as it is a per se known type. For example, the female connector can be of the valved type described and illustrated in the document EP-1834665, also by the Applicant.

The inlet portion 7 communicates with a tubular appendage 8, which is also integrally formed with the flange 2 and protrudes at the rear of the casing 1, for example, configured for attachment of a flexible line connected to a bag containing a medical liquid for infusion.

The inlet portion 7 and the outlet portion 6 are connected to each other by means of two series of separate passages 9, 10 whose mutual communication is

- 5 -

controlled in the manner explained below.

The outlet portion 6 of the tubular member 5 has one open terminal end, indicated by 11, at which an annular enlargement 12 is formed, which defines the upper limit of an outer annular groove 13, in turn having a lower limit defined by a stop step 14.

Numeral 15 indicates an elastic hollow element, typically made of elastomeric rubber or silicone, including an annular base 16 secured to the casing 1 between the flange 2 and the body 3, a generally cylindrical first part 17 connected to the base 16 by means of a generally conical part 18 diverging towards this first cylindrical part 17, and a second generally cylindrical part 19, slightly narrower than the first cylindrical part 17 and having a terminal transverse wall 20.

The terminal wall 20 has a central cut 21, for example, linear or of tricuspid form, as in the case of the example illustrated, which is normally closed due to the intrinsic elasticity of the elastic hollow element 15 in order to essentially seal closed the open terminal end 11 of the tubular member 5.

The second cylindrical portion 19 of the elastic hollow element 15 is internally formed with an annular guiding protrusion 23, slidable within the groove 13 of the inlet portion 6 of the tubular member 5, between the annular enlargement 12 and the step 14.

The first cylindrical part 17 of the elastic hollow element 15 has, internally, a first, a second and a third annular sealing protrusion axially spaced apart from each other, indicated respectively by 24, 25 and 26 and in slidable sealing contact on the tubular member 5. The annular protrusion 24 interacts with the passages 9 and 10 to close and open, respectively, the communication between the inlet portion 7 and the

- 6 -

outlet portion 6 of the tubular member 5. In the condition represented in Figure 2, the passages 9 and 10 are isolated from each other by the annular sealing protrusion 24, while in the condition represented in Figure 5, passages 9 and 10 are in communication.

The reference 28 indicates a collar interposed between the hollow body 3 of the casing 1 and the elastic hollow element 15, forming an actuator member, configured for controlling the opening of the flow passage through the connector due to a stretching deformation of the elastic hollow element 15. The collar 28 has an outer annular step 29, arranged to cooperate, in the manner described in the aforementioned document EP-2504056, with a female luer connector or the like, coupled in the seat 4 of the body 3. As a result of this coupling, the female connector applies an axial thrust against the step 29 of the collar 28 in order to push it in the direction of the inlet portion 7 of the tubular member 5 and to elastically deform the elastic hollow element 15 in order to open the flow passage between the tubular appendage 8 and the female connector through the terminal end 11 of the outlet portion 6 of the tubular member 5, in the manner represented in Figure 5 which will be discussed below.

According to the unique characteristic of the invention, the valved male luer connector is also equipped with a priming cap, indicated as a whole by 30, which is designed to be releasably connected to the casing 1 to keep the connector in a condition of at least partial opening before its coupling with the female connector. In this way, during use, the medical liquid coming from the line connected to the tubular appendage 8 is able to reach the terminal end 11 of the tubular member 5 without the need for a priming

- 7 -

intervention by the operator, thus rendering the valved male luer connector ready for its coupling to the female connector for the supply of medical liquid to a patient.

5 The priming cap 30 comprises a ridged skirt 31, configured in order to externally enclose the hollow body 3 of the connector, and a tubular part coaxial to the skirt 31 and having an outer portion 32 projecting axially beyond the skirt 31 and an inner portion 33 protruding inside this skirt 31. The outer portion 32 carries a transversal liquid-impermeable barrier, typically formed of a hydrophobic membrane 34, while the inner portion 33 is configured to interact with the step 29 of the collar 28.

15 The skirt 31 of the priming cap 30 is selectively engageable with the casing 1, in a first axial position, represented in Figure 2, or in a second axial position represented in Figure 5. In the first position, the skirt 31 engages with the body 3, for example, by simple interference, essentially without interacting with the collar 28 and therefore without deforming the elastic hollow element 15. Therefore, in this first position, the valved connector remains closed and the priming cap 30 acts as a simple cover to protect the end wall 20 of the elastic hollow element 15.

20 In the second axial position represented in Figure 5, the inner end part 33 of the priming cap 30 interacts with the step 29 of the collar 28, elastically deforming the elastic hollow element 15.

30 To arrange and stably maintain the priming cap 30 in the second axial position, two opposing slots 35 are formed at the base of the skirt 31, configured to cooperate with a complementary pair of radial projections 36 of the body 3 to achieve a rotation

35

- 8 -

coupling of the bayonet type .

In this second axial position, as said, represented in Figure 5, the priming cap 30 is secured to the body 3 due to the engagement of the slots 35 of the skirt 31 relative to the protrusions 36 of the body 3, under the elastic thrust applied by the elastic hollow element 15, displaying stretching deformation, against the step 29 of the collar 28.

Following the stretching deformation of the elastic element 15, the inner annular protrusion 24 of the elastic element 15 is arranged downwards, in order to free the communication between the radial passages 9 and 10 and therefore between the inlet 7 and the outlet 6 portions of the tubular member 5, while the cut 21 of the end wall 20 is simultaneously opened, thereby placing the end 11 of the outlet portion 6 of the tubular member 5 in communication with the outer tubular portion 32 of the priming cap 30. The tubular connector 8, and therefore the line connected to it during use, are thus maintained in communication with the atmosphere through the membrane 34 which, as said, constitutes an impermeable barrier to the medical liquid coming from the line.

In this way, the valved male luer connector according to the invention, without any risk of liquid loss, is ready for subsequent coupling with the female connector, without the need for further priming operations: it is in fact sufficient to remove the cap 30, disengaging the bayonet coupling 35-36, to then be able to apply the female connector in its replacement.

Of course, the details of construction of the embodiments may be widely varied with respect to those described and illustrated, without thereby departing from the scope of the present invention as defined by the following claims.

- 9 -

CLAIMS

1. Valved male luer connector comprising a casing (1), a tubular member (5) having an inlet portion (7) and an outlet portion (6) with an open terminal end (11), an elastic hollow element (15) secured to the casing (1) and enclosing the tubular member (5), said elastic hollow element (15) having a terminal wall (20), which normally seals closed said terminal end (11) of the outlet portion (6) of the tubular member (5) and having a cut (21), and a collar (28) interposed between the casing (1) and the elastic hollow element (15) and axially displaceable, following thrust engagement by a female connector connectable to said male connector, causing a stretching deformation of said elastic hollow element (15) and consequent opening of the flow passage between said inlet portion (7) and said outlet portion (6) of the tubular member (5), characterized in that it comprises a priming cap (30) designed to be releasably connected to the casing (1) of the connector to provide stretching deformation of said elastic element (15) and to keep said terminal end (11) of the outlet portion (6) of the tubular member (5) in communication with the atmosphere through a liquid-impermeable barrier (34), said priming cap (30) comprising a skirt (31) arranged outside the casing (1) and configured to engage said casing (1) and a tubular part (32, 33) coaxial to said skirt (31), which carries said liquid-impermeable barrier (34) and is arranged to interact with said collar (28) interposed between the casing (1) and the elastic hollow element (15).

2. Valved connector according to claim 1, characterized in that said skirt (31) of the priming cap (30) can be selectively engaged with said casing

- 10 -

(1) in a first axial position to protect said terminal wall (20) of the elastic hollow element (15), in which said elastic hollow element (15) is essentially undeformed, and in a second axial position wherein said
5 elastic hollow element (15) is stretched, respectively.

3. Connector according to claim 2, characterized in that said skirt (31) of the priming cap (30) in said second axial position is connected to the casing (1) of the connector by means of a bayonet coupling (35, 36).

10 4. Connector according to any one of the preceding claims, characterized in that said liquid-impermeable barrier consists of a hydrophobic membrane (34).

FIG. 1

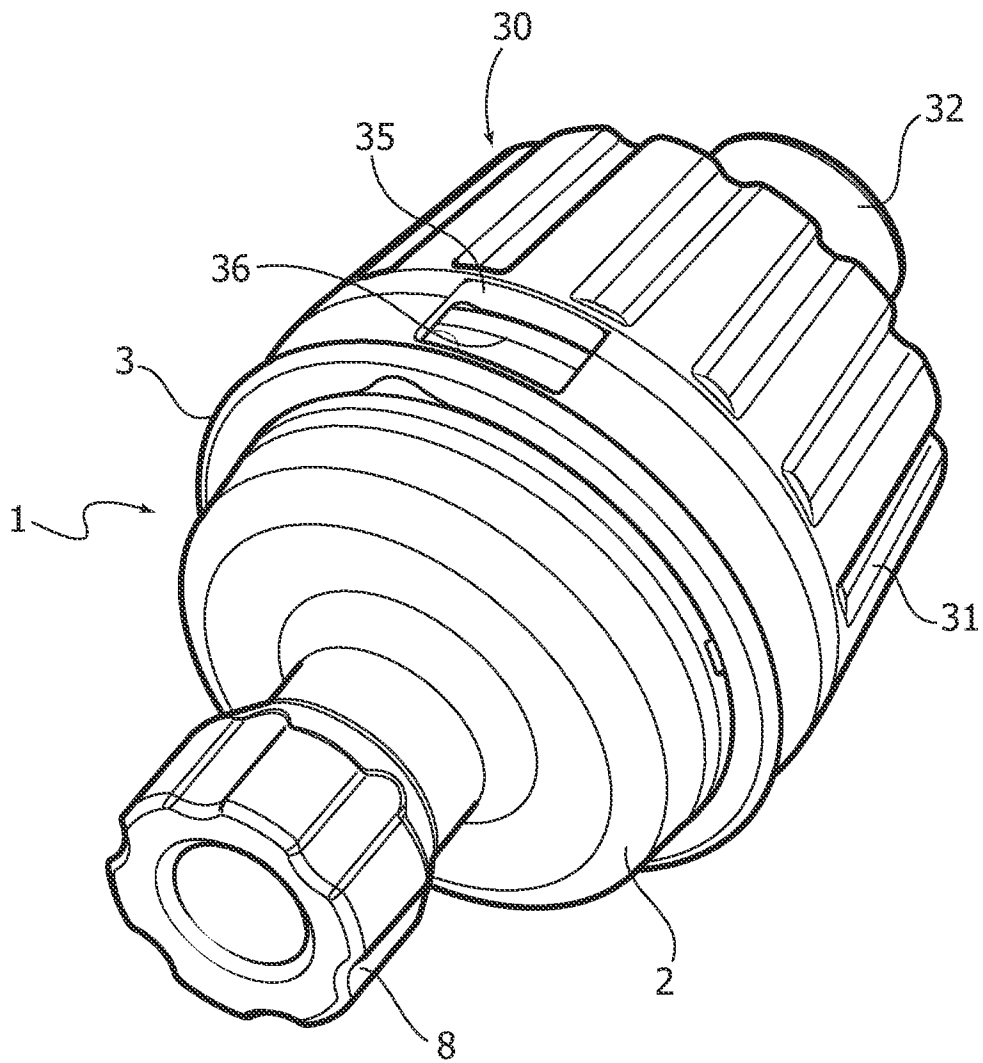

FIG. 3

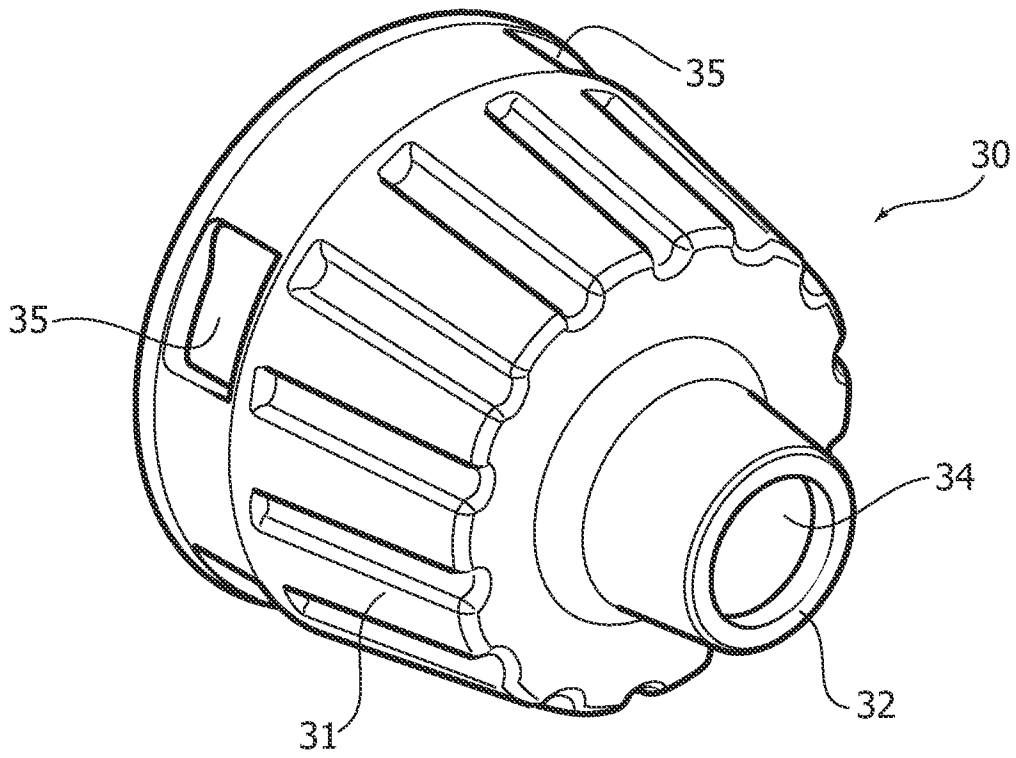
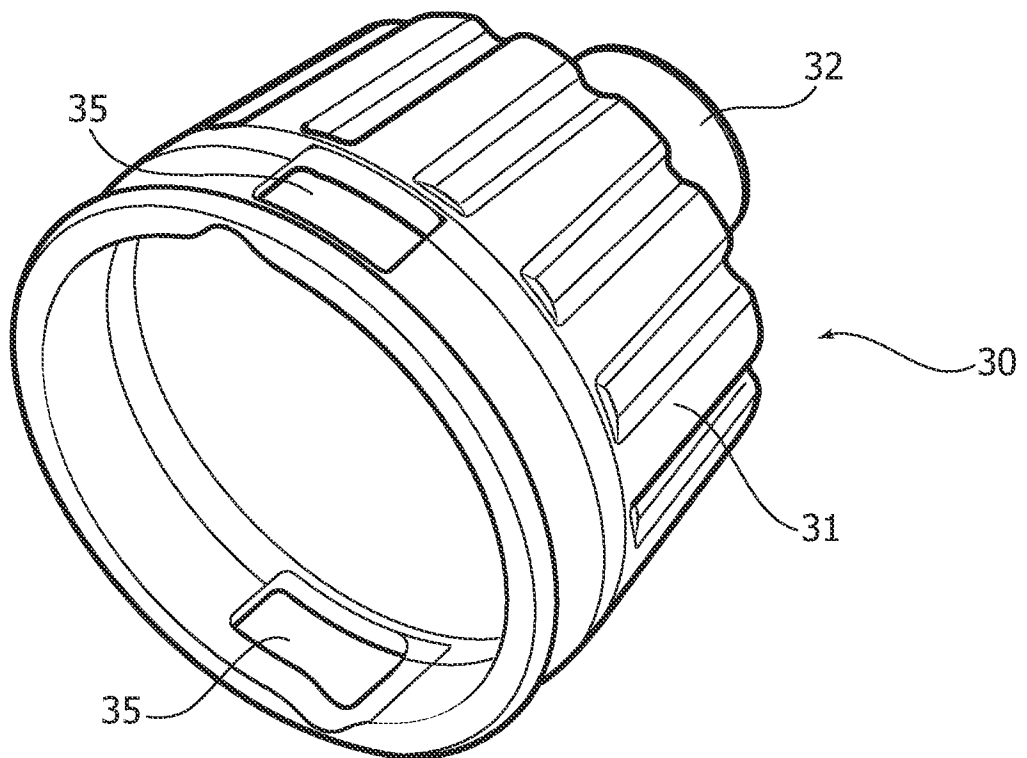

FIG. 4



INTERNATIONAL SEARCH REPORT

International application No
PCT/IB2014/067444

A. CLASSIFICATION OF SUBJECT MATTER
INV. A61M39/10 A61M39/20
ADD.
According to International Patent Classification (IPC) or to both national classification and IPC

B. FIELDS SEARCHED
Minimum documentation searched (classification system followed by classification symbols)
A61M

Documentation searched other than minimum documentation to the extent that such documents are included in the fields searched

Electronic data base consulted during the international search (name of data base and, where practicable, search terms used)
EPO-Internal, WPI Data

C. DOCUMENTS CONSIDERED TO BE RELEVANT

Category*	Citation of document, with indication, where appropriate, of the relevant passages	Relevant to claim No.
A	WO 2011/064738 A2 (BORLA IND [IT]; GUALA GIANNI [IT]) 3 June 2011 (2011-06-03) cited in the application figure 2	1-4
A	----- US 5 032 116 A (PETERSON GERALD H [US] ET AL) 16 July 1991 (1991-07-16) figure 2 column 1, lines 4-11 column 2, lines 38-40 column 3, lines 38-40; figure 2	1-4
A	----- WO 2004/014477 A1 (KIM YONG-NYUN [KR]) 19 February 2004 (2004-02-19) page 1, lines 11-21; figure 3 page 2, line 30 - page 3, line 4 page 8, line 6	1-4
	----- -/--	

Further documents are listed in the continuation of Box C.

See patent family annex.

* Special categories of cited documents :

- "A" document defining the general state of the art which is not considered to be of particular relevance
- "E" earlier application or patent but published on or after the international filing date
- "L" document which may throw doubts on priority claim(s) or which is cited to establish the publication date of another citation or other special reason (as specified)
- "O" document referring to an oral disclosure, use, exhibition or other means
- "P" document published prior to the international filing date but later than the priority date claimed

- "T" later document published after the international filing date or priority date and not in conflict with the application but cited to understand the principle or theory underlying the invention
- "X" document of particular relevance; the claimed invention cannot be considered novel or cannot be considered to involve an inventive step when the document is taken alone
- "Y" document of particular relevance; the claimed invention cannot be considered to involve an inventive step when the document is combined with one or more other such documents, such combination being obvious to a person skilled in the art
- "&" document member of the same patent family

Date of the actual completion of the international search 8 April 2015	Date of mailing of the international search report 16/04/2015
Name and mailing address of the ISA/ European Patent Office, P.B. 5818 Patentlaan 2 NL - 2280 HV Rijswijk Tel. (+31-70) 340-2040, Fax: (+31-70) 340-3016	Authorized officer Herz, Markus

INTERNATIONAL SEARCH REPORT

International application No
PCT/IB2014/067444

C(Continuation). DOCUMENTS CONSIDERED TO BE RELEVANT		
Category*	Citation of document, with indication, where appropriate, of the relevant passages	Relevant to claim No.
A	EP 0 081 655 A1 (INTERMEDICAT GMBH [CH]) 22 June 1983 (1983-06-22) figure 1 -----	1-4

INTERNATIONAL SEARCH REPORT

Information on patent family members

International application No

PCT/IB2014/067444

Patent document cited in search report	Publication date	Patent family member(s)	Publication date	
WO 2011064738	A2	03-06-2011	AU 2010325551 A1	14-06-2012
			CA 2781833 A1	03-06-2011
			CN 102971041 A	13-03-2013
			EP 2504056 A2	03-10-2012
			ES 2429841 T3	18-11-2013
			JP 2013512028 A	11-04-2013
			PT 2504056 E	22-10-2013
			US 2012271246 A1	25-10-2012
			WO 2011064738 A2	03-06-2011
US 5032116	A	16-07-1991	AT 136227 T	15-04-1996
			AU 638663 B2	01-07-1993
			AU 8835491 A	23-07-1992
			CA 2056048 A1	10-07-1992
			DE 69209530 D1	09-05-1996
			DE 69209530 T2	02-10-1996
			EP 0494779 A1	15-07-1992
			ES 2088093 T3	01-08-1996
			JP H0698190 B2	07-12-1994
			JP H04295373 A	20-10-1992
			NO 914981 A	10-07-1992
			NZ 240690 A	27-04-1994
			US 5032116 A	16-07-1991
			WO 2004014477	A1
EP 1534379 A1	01-06-2005			
JP 4295217 B2	15-07-2009			
JP 2005535379 A	24-11-2005			
US 2005203460 A1	15-09-2005			
WO 2004014477 A1	19-02-2004			
EP 0081655	A1	22-06-1983	DE 3147499 A1	09-06-1983
			DK 533682 A	02-06-1983
			EP 0081655 A1	22-06-1983
			ES 268873 U	01-06-1983
			FI 823673 A	02-06-1983
			NO 823501 A	02-06-1983