

(19) AUSTRALIAN PATENT OFFICE

- (54) Title
Articulating Spinal Implant
- (51) ⁶ International Patent Classification(s)
A61F 002/44
- (21) Application No: 2002301243 (22) Application Date: 2002.09.27
- (43) Publication Date : 2003.02.27
- (43) Publication Journal Date : 2003.02.27
- (62) Divisional of:
749335
- (71) Applicant(s)
SDGI Holdings, Inc.
- (72) Inventor(s)
Cauthen, Joseph C7
- (74) Agent/Attorney
Spruson & Ferguson, Level 35 St Martins Tower 31 Market
Street, Sydney, NSW, 2000
- (56) Related Art
WO 1998/14142
WO 1993/10725
EP 0042271

Articulating Spinal Implant

Abstract

A spinal implant [10] for intervertebral disc replacement. The implant [10] is formed from two hemicylindrical elements [20, 22], each engaging one of an adjacent pair of vertebrae [12, 14]. An articulating ball-and-socket joint [24] between the two elements [20, 22] resists compression and lateral movement between the vertebra [12, 14], but allows pivotal movement, thereby preserving mobility. Fusion chambers [30, 34] are provided for allowing bone ingrowth to fuse the elements [20, 22] to the vertebrae [12, 14]. Biocompatible, bioreabsorbable struts, shims, fillers and/or end caps are provided for temporary stabilisation of the first and second hemicylindrical elements [20, 22].

10 Bone chips removed from the vertebrae [12, 14] during implantation or bone growth stimulators can be inserted into the fusion chamber [30, 34] or otherwise applied to the implant [10] to enhance bone ingrowth.

AUSTRALIA

PATENTS ACT 1990

COMPLETE SPECIFICATION

FOR A STANDARD PATENT

ORIGINAL

Name and Address of Applicant : SDGI Holdings, Inc.
Suite 508
300 Delaware Avenue
Wilmington Delaware 19801
United States of America

Actual Inventor(s): Joseph C Cauthen

Address for Service: Spruson & Ferguson
St Martins Tower, Level 35
31 Market Street
Sydney NSW 2000
(CCN 3710000177)

Invention Title: Articulating Spinal Implant

The following statement is a full description of this invention, including the best method of performing it known to me/us:-

Articulating Spinal Implant

Background of the Invention

1. Field of the Invention

The invention relates generally to a spinal implant for use in intervertebral disc replacement; 5 and more specifically relates to an articulating implant that fuses to adjacent vertebrae by bone ingrowth, thus restoring proper intervertebral spacing, and eliminating nerve root and/or spinal cord compression, while preserving spinal flexibility.

2. Description of Related Art

The spinal column is formed from a number of vertebrae, which in their normal state are 10 separated from one another by cartilaginous intervertebral discs. These discs form a cushion between adjacent vertebrae, resisting compression along the support axis of the spinal column, but permitting limited movement between the vertebrae to provide the characteristic flexibility of the healthy spine. Injury, disease or other degenerative disorders may cause one or more intervertebral discs to shrink, collapse, deteriorate or become displaced, herniated or otherwise damaged. This can lead to 15 compression of adjacent nerve root(s) or the spinal cord causing chronic and often disabling pain, and in advanced circumstances, irreversible paralysis of upper and/or lower limbs.

A number of devices and methods have been suggested for the replacement of damaged or dislocated intervertebral discs. One common approach is to permanently stabilise or "fuse" the adjacent vertebrae to maintain the proper intervertebral spacing and eliminate relative movement 20 between the vertebrae. Various methods of vertebral stabilisation have been developed. For example, autogenous grafts of dowel-shaped sections of bone have been implanted between the vertebrae to cause bone growth across the intervertebral space, thereby fusing the adjacent vertebrae into one bone mass. This procedure disadvantageously requires the harvest of donor bone for the graft from other parts of the patient's body, typically requiring a separate surgical procedure and resultant 25 increases in complications and expense. An alternative source is cadaver bone, with potential complications of transmissible diseases, impaired graft incorporation, collapse or displacement. A further development to this method of vertebral stabilization involves the implantation of a perforated cylindrical bone basket between adjacent vertebrae. Bone fragments produced in preparing the vertebrae for the implantation are inserted into the bone basket to promote bone growth into, through 30 and around the basket.

Vertebral stabilisation by fusion of adjacent vertebrae has proven successful in permanently preserving intervertebral spacing, but has been found to present a number of disadvantages. Fusion of adjacent vertebrae necessarily eliminates a portion of the spine's normal range of motion, thereby reducing the subject's spinal flexibility. Additionally, fusion of the vertebrae increases the stresses 35 imposed on adjacent mobile portions of the spinal column, often hastening the subsequent breakdown of normal joint surfaces above and below the fused vertebrae.

It has also been proposed to replace an injured intervertebral disc with a prosthesis which is "jointed" to permit relative movement between vertebrae. Previously-known devices of this type generally have been found to suffer from inadequate attachment between the prosthesis and the 40 vertebrae. The intended movement between the components of previously-known jointed prostheses

can cause relative motion between the prosthesis and adjacent bone surface(s). Because such motion would disrupt bone ingrowth, jointed prostheses have generally been considered incompatible with attachment by bone ingrowth. In addition, because the joint elements of these devices typically must occupy a substantial vertical extent in order to achieve the desired range of motion, and yet must fit within the intervertebral space, attachment of such devices generally has been by use of flat plates or surfaces provided on either side of the joint elements as points of fixation to the vertebrae. This attachment may be accomplished by compressive or friction fits, spiked projections, screws or pins, complemented in some instances with tissue ingrowth into porous surfaces. These mechanisms of attachment, however, may lack the degree and strength of fixation desired. Moreover, several such devices have used attachment flanges which extend beyond the surfaces of the vertebrae to which the device is attached. This has been found undesirable, as the extending flanges may interfere with or injure adjacent tissue. For example, it has been reported that flanges extending into immediately adjacent delicate oesophageal area may interfere with swallowing and speech, or cause perforation and potentially fatal infection. An additional drawback to the use of screw and pin connections is the potential for such connectors to dislodge and cause injury.

Thus, it can be seen that a need yet exists for a spinal implant effective in permanently maintaining intervertebral spacing to prevent nerve or spinal cord compression while preserving as much of the natural range of motion between the affected vertebrae as possible. A need further exists for such a device which is capable of forming a permanent, strong attachment to the vertebrae and yet does not protrude beyond the external surfaces to which it is attached. Still another need exists for a method of replacing a damaged or displaced disc, which method maintains intervertebral spacing to prevent nerve and spinal cord compression, while preserving the natural relative motion between the vertebrae. It is to the provision of a device and method meeting these and other needs that the present invention is primarily directed.

Brief Summary of the Invention

The invention provides a spinal implant comprising: a first element comprising a first articulation surface and a first threaded outer surface adapted to engage a first vertebra; a second element comprising a second articulation surface and a second threaded outer surface adapted to engage a second vertebra; and wherein said first and second articulation surfaces cooperate to allow relative movement between said first and second elements.

The invention also provides a spinal implant, comprising:

a first element comprising a first articulation surface and a first outer surface defining a first convex lateral curvature extending substantially entirely across a width of the implant and adapted to engage a first vertebra;

a second element comprising a second articulation surface and a second outer surface defining a second convex lateral curvature extending substantially entirely across said width of the implant and

adapted to engage a second vertebra; and wherein said first and second articulation surfaces cooperate to allow relative movement between said first and second elements.

Also provided by the invention is a spinal implant, comprising:

5 a first element comprising a first articulation surface and a first outer surface adapted to engage a first vertebra;

a second element comprising a second articulation surface and a second outer surface adapted to engage a second vertebra; and

10 wherein one of said first and second articulation surfaces defines an elongate rocker and the other of said first and second articulation surfaces defines an elongate channel, at least a portion of said rocker being engaged within said channel to allow relative movement between said first and said second elements.

The invention further provides a spinal implant, comprising: a first element having a first outer surface adapted to engage a first vertebra; a second element having a second outer surface adapted to engage a second vertebra; and a stabilisation element adapted to temporarily stabilise said first and second elements to facilitate fusion with the first and second vertebra.

15 Also provided by the invention is a method of maintaining an intervertebral space between a first vertebra and a second vertebra, comprising:

providing a spinal implant having a first element and a second element, the first element having a first articulation surface and a first threaded outer surface, the second element having a second articulation surface and a second threaded outer surface;

20 engaging the first threaded outer surface of the first element against a portion of the first vertebra;

engaging the second threaded outer surface of the second element against a portion of the second vertebra; and

25 adjoining the first and second articulation surfaces to permit relative movement between the first and second elements.

Briefly described, in a preferred form, the present invention comprises a spinal implant including a first element having first connection means for engaging a first vertebra. The first connection means includes a first fusion chamber having at least one opening therein for facilitating bone ingrowth into the first fusion chamber to fuse the first element to the first vertebra. The implant also includes a second element having second connection means for engaging a second vertebra. The second connection means includes a second fusion chamber having at least one opening therein for facilitating bone ingrowth into the second fusion chamber to fuse the second element to the second vertebra. The implant also includes internal articulation means, coupling the first element to the second element, for allowing relative movement between the first element and the second element. The term "internal articulation means," is intended to mean a device that permits relative motion

between components of the device, rather than between the device and an external structure such as adjacent bone or other tissue.

5 In specific embodiments of the subject invention, the first and second element may have either hemicylindrical or hemielliptical shaped outer surfaces. The first and second elements each having an outer wall perforated with one or more openings provided therein to allow bone ingrowth into the fusion chambers, and having abutting joint surfaces forming the internal articulation means. In a further preferred embodiment, the joint surfaces are formed as engaging concave and convex surfaces to create a ball-and-socket type joint (or groove and channel, or other such joint), which allows relative pivotal motion between the vertebrae, but resists compression therebetween.

10 The first and second elements can join to form a single element which can be implanted using methods similar to those followed in the implantation of previously-known non-articulating vertebral fusion implants. Temporary stabilising means can be provided for rigidly coupling the first and second elements by interposition of bioreabsorbable elements to permit implantation and enable bone ingrowth into the fusion chambers and fusion of the first and second elements to adjacent bone during an initial stabilisation period, after which said temporary means biodegrades permitting articulation
15 between the first and second elements.

The present invention can be further described as comprising a spinal implant having a first articulation surface, a second articulation surface engaging at least a portion of the first articulation surface along a support axis generally parallel to the spinal column, first connection means for connecting the first articulation surface to a first vertebra, and second connection means for connecting the second articulation surface to a second vertebra. The first and second articulation surfaces resist axial compression between the first and second elements in the direction of the support axis, but allow relative pivotal motion between the first and second elements. At least one, and preferably both, of the first connection means and the second connection means comprise a fusion chamber having at least one opening therein for facilitating bone ingrowth, thereby permanently and securely affixing the implant in place.

In another preferred form, the present invention comprises a method of maintaining an intervertebral space between a first vertebra and a second vertebra. The method includes the steps of removing a section of the first vertebra to form a cavity therein, mounting a first element of a spinal implant within the cavity formed in the first vertebra, and connecting a second element of the spinal implant to the second vertebra. The first element includes a first articulation surface and a first fusion chamber having at least one opening therein for facilitating bone ingrowth from the first vertebra. The second element includes a second articulation surface, wherein the first and second articulation surfaces adjoin to form a joint allowing relative pivotal movement between the first and second elements but preventing relative compression between the first and second elements. In a further preferred embodiment, the method may also include the removal of a section of the second vertebra to form a cavity for receiving the second element. The second element may also include a second fusion chamber for facilitating bone ingrowth from the second vertebra. Bone fragments formed by the removal of vertebral sections to accommodate implantation or bone growth stimulating compounds or devices may be inserted into the fusion chamber(s) to enhance bone ingrowth.

These and other objects, features and advantages of the present invention will be more readily understood with reference to the following detailed description, read in conjunction with the accompanying drawing figures.

Brief Description of the Drawings

Figure 1A and 1B show a perspective view of a spinal implant according to one cylindrical form of the present invention.

Figure 2 shows a cross-sectional side view of the spinal implant of FIG. 1.

Figure 3 shows a cross-sectional end view of the spinal implant of FIG. 1.

Figure 4a is an end view of a spinal implant *in situ* according to the cylindrical form of the present invention.

Figure 4b is a side view of a spinal implant *in-situ* according to the cylindrical form of the present invention.

Figure 5 is a cross-sectional end view of another embodiment of the present invention.

Figure 6a shows a cross-sectional end view of an elliptically shaped spinal implant of the subject invention.

Figure 6b shows a cross-sectional end view of an alternative elliptically shaped spinal implant of the subject invention.

Figure 7 shows a cross-sectional side view of the tapered spinal implant.

Figure 8 shows a cross-sectional end view of a spinal implant with a rocker and channel articulating means.

Figure 9 shows a cross-sectional end view of a spinal implant with a rocker and hour-glass channel articulating means.

Figures 10a & 10b show a perspective view of a spinal implant with a rocker and alternative hour-glass channel articulating means.

Figures 11a & 11b show a perspective view of a spinal implant with a rocker and alternative hour-glass channel articulating means.

Figure 12 is an end view of a spinal implant *in-situ* according to the elliptical form of the present invention.

Figure 13 is a side view of a spinal implant *in-situ* according to the tapered form of the present invention.

Figure 14 shows a surgical instrument for cutting an elliptical section in between spinal vertebra.

Detailed Disclosure of the Invention

Referring now in detail to the figures wherein like reference numbers represent like parts throughout, preferred forms of the present invention will now be described. As seen in Figs. 1-3, one embodiment of the present invention comprises a spinal implant 10, generally comprising a first element 20 and a second element 22. The first element 20 is coupled to the second element 22 by an internal articulation means 24 for allowing relative pivotal movement between the first and second elements.

Figures 4A and 4B show the spinal implant 10 of the present invention installed *in situ*, between a first vertebra 12 and a second vertebra 14. The implant 10 is shown implanted into an anterior aspect of the vertebral body, between the fifth cervical and sixth cervical vertebra. The device and method of the present invention, however, are applicable to anterior and posterior approaches to the vertebrae.

As seen best in Figs. 2-3, the first element 20 of the implant 10 comprises first connection means, in the form of a first fusion chamber 30, for engaging the first vertebra 12. At least one opening 32 is formed in the first fusion chamber 30, to facilitate bone growth into, through and around the first fusion chamber 30 from the first vertebra 12, to fuse the first element to the first vertebra 12. Preferably, a plurality of openings 32 are provided to further promote bone ingrowth. Fusion by bone ingrowth has been found to provide a more permanent, rigid connection between the implant 10 and the skeletal structure than provided by other known connection means.

The second element 22 of the implant 10 comprises a second connection means for engaging the second vertebra 14. The second connection means preferably comprises a second fusion chamber 34, substantially similar in construction to the above-described first fusion chamber 30, and comprising at least one opening 36 formed therein for facilitating bone growth into, through and

around the second fusion chamber 34 from the second vertebra 14. Alternatively, the second connection means can comprise an adhesive connection, screw connection, pin connection, or any other effective alternative connection means. However, the provision of a second fusion chamber 30 is preferred, as it provides a more permanent and secure coupling than other known attachment means. Although the first element 20 and first vertebra 12 are depicted in the figures as above the second element 22 and second vertebra 14, it will be understood that the present invention equally comprehends the reverse configuration wherein the first element, as described herein, is attached to a first vertebra lower on the spinal column than the second vertebra to which is attached the second element. The first and second elements can be fabricated from biocompatible materials including, without limitation, titanium, surgical alloys, stainless steel, chrome-molybdenum alloy, cobalt chromium alloy, zirconium oxide ceramic, nonabsorbable polymers and other anticipated biocompatible metallic or polymeric materials.

Referring now to Figs. 2-3, the articulation means 24 of the present invention preferably comprises a first articulation surface 40 provided on the first element 20, and an abutting second articulation surface 42 provided on the second element 22. The first and second articulation surfaces 40,42 are preferably fabricated from or coated with low-friction, wear and impact-resistant, biocompatible materials, such as, for example, titanium, stainless steel, surgical alloys, chrome molybdenum alloys, cobalt chromium alloy, zirconium oxide ceramic, non-absorbable polymers and other biocompatible metallic or polymeric materials. The articulation means 24 resists axial compression between the first and second elements 20, 22, but allows relative pivotal movement therebetween. Thus, when implanted, as shown in Figure 4, the articulation means 24 resists axial compression between first and second vertebra 12, 14 along a support axis 44 extending generally along the spinal column, as shown, for example, in Figure 4, but permits pivotal movement between vertebrae. The term "pivotal," is intended to comprehend either or both of a rotational or twisting motion about the support axis 44 (for example, rotation between cervical vertebrae by turning the head to the right or left), and/or a tilting motion angularly inclined in any direction relative to the support axis 44 (for example, nodding the head forward or backward and/or tilting the head downward to the right or left).

Axial compression, as well as lateral translation normal to the support axis 44, is resisted between the first and second vertebra 12, 14, by providing the first internal articulation surface 40 with a void, such as a concave surface 46, which receives a protuberance, such as a convex surface 48, projecting from the second internal articulation surface 42. This "ball-and-socket" arrangement allows relative rotation about the support axis 44 between the first and second vertebra 12, 14. The articulation means 24 can be provided with one or more stops to limit the range of rotational movement allowed.

In addition to the "ball-and socket" arrangement for the articulating means 24 other configurations are possible. In an alternative embodiment, as shown in Figures 8 and 10, the articulating means comprises a rocker 100 and channel 101. The second articulation surface 42 can comprise a substantially U-shaped channel 101 extending along the length of the second element 22. The first articulation surface 40 comprises a correspondingly-shaped rocker 100 which can be, for

example, hemielliptical in shape along the length of the first element 20. Such an arrangement permits a tilting motion in one plane. In an alternative to this embodiment, as shown in Figure 9, a second range of motion can be added to the articulating means 24 by modifying the shape of the channel 102. The modified channel 102 can be, for example, substantially hour-glass in shape through the depth of the channel 102. The channel width at the channel's base 103 and mouth 104 are greater than the channel width at the channel's midpoint 105. The hour-glass shaped channel 102 permits a tilting motion along two perpendicular linear planes.

In a second alternative to this embodiment, as shown in Figure 11, an alternative second range of motion can be added to the articulating means 24 by modifying the shape of the channel 106. The modified channel 106 can be, for example substantially hour-glass in shape through the length of the second element 22. The channel width at the channel's longitudinal midpoint 107 is less the channel width at the channel leading end 108 and tail end 109. Those skilled in the art, having the benefit of the instant disclosure, will appreciate that the "hour-glass" shape as described herein includes various curves or straight edges so long as the width at, or near, the end points of the channel (or the top and bottom of the channel) is wider than the width at some point between the end points. The hour-glass shaped channel 106 permits two ranges of motion, a tilting motion and a pivoting motion about the central axis. These motions may be desirable for some patients.

The articulation means 24 preferably further comprises one or more angularly offset bevels 50 formed in the first internal articulation surface 40 and/or the second internal articulation surface 42, to allow relative tilting movement between the first and second vertebra 12, 14 in one or more directions. According to the embodiment shown in the figures, the first and second internal articulation surfaces 40,42 are each provided with an angularly offset bevel 50, in a generally pyramidal configuration, as seen best in Figure 9, thereby enabling tilting movement in all directions (360°). A generally conical configuration is also possible and, likewise, would permit both rotational movement and 360° tilting movement. Additionally, as shown in Figures 10 and 11, the first and second articulating surfaces 40, 42 can each be provided with a general arc configuration, which provide a greater range of motion.

The natural range of motion of the spine may be approximated by providing bevels 50 of approximately 5° around the periphery of each of the first and second articulation surfaces 40,42, thereby allowing approximately 10° of tilt in all directions between adjacent vertebrae. As depicted in the figures, the pivot point or axis of the articulation means 24 is generally centrally located on the first and second articulation surfaces 40, 42, and will be aligned with the spine's normal axis of rotation when implanted as shown in Figure 4. This location, however, can be selectively varied to position the centre of rotation of the articulation means 24 centrally, anteriorly, posteriorly, to the left, to the right, or eccentrically (off-centre in both the anterior/posterior direction and the left/right direction) of the spine's normal axis of rotation, in order to achieve proper alignment of the spine, thereby restoring optimal sagittal and coronal spinal balance and alignment.

In one embodiment as shown best by Figure 1, the first and second elements 20, 22 of the implant 10 of the present invention preferably comprise generally hemicylindrical outer walls 60, 70 adjoining to form a generally cylindrical body. When in their assembled configuration, the first element 20 and the second element 22 abut one another with their respective first and second articulating

surfaces 40,42 adjacent and engaging one another, as described above. The first element 20 preferably further comprises a first radiused outer wall 60. The one or more openings 32 for facilitating bone ingrowth are provided in this first radiused outer wall 60, and communicate with a first fusion chamber 62 formed between the first radiused outer wall 60 and the first articulating surface 40.

5 Similarly, the second element 22 preferably comprises a second radiused outer wall 70, defining one or more openings 36 for facilitating bone ingrowth. The openings 36 communicate with a second fusion chamber 72 formed between the second radiused outer wall 70 and the second articulating surface 34. The first and second radiused outer walls 60,70 can be provided with threads 80 to facilitate advancing the implant 10 into the intervertebral space during implantation and to help secure

10 the implant 10 in position once implanted. The threads 80 on each of the first and second radiused outer walls 60, 70 are preferably aligned to form continuous threads when the first and second elements 20, 22 are engaged. In some instances, it may be desirable to provide self-tapping threads 80, and/or to configure the threads 80 to direct bone fragments generated by implantation into the openings 32, as taught by U.S. Patent No. 5,489,308 to Kuslich *et al.* In other less preferred

15 embodiments, the threads 80 can be replaced with a contoured outer surface comprising smooth, splined, flanged, spiked or beaded surface features. The implant 10 can further comprise one or more support flanges 85 in the first and/or second elements 20, 22, for additional strength.

In a second embodiment as shown best by Figures 6a, 6b and 12, the first and second elements 20,22 of the implant 10 of the present invention preferably comprise generally hemielliptical

20 outer walls 97, 99 adjoining to form a generally elliptical body. When in their assembled configuration, the first element 20 and the second element 22 abut one another with their respective first and second articulating surfaces 40,42 adjacent and engaging one another, as described above. The first element 20 preferably further comprises a first radiused outer wall 97. The one or more openings 32 for facilitating bone ingrowth are provided in this first radiused outer wall 97, and communicate with a first

25 fusion chamber 62 formed between the first radiused outer wall 97 and the first articulating surface 40. Similarly, the second element 22 preferably comprises a second radiused outer wall 99, defining one or more openings 36 for facilitating bone ingrowth. The openings 36 communicate with a second fusion chamber 72 formed between the second radiused outer wall 99 and the second articulating surface 42. In alternative embodiments the contoured outer surfaces of the first 20 and 22 second

30 elements can comprise smooth, splined, flanged, spiked or beaded surface features to secure the element in position once implanted. The implant 10 can further comprise one or more support flanges 85 in the first and/or second elements 20, 22, for additional strength.

In another embodiment, as shown in Figures 7 and 12, the element 10 may be tapered along the horizontal axis. The tailing end 92 having a vertical radius greater than the vertical radius of the

35 leading end 93. The tapered shape decreases the amount of material required to be removed and increases the ease of insertion of the implant 10 in between the first and second vertebra.

In a further preferred embodiment, the present invention may further comprise the provision of one or more stabilising means for temporarily rigidly coupling the first element 20 to the second element 22 to prevent relative movement therebetween. For example, it is preferred that the first and

40 second elements 20, 22 be held rigidly in place during installation of the implant 10 into the

intervertebral space. In addition, the first and second elements 20, 22 should remain rigidly coupled for a sufficient length of time after implantation to permit sufficient bone ingrowth into the fusion chambers to prevent relative motion between the implant 10 and the vertebrae 12, 14 during normal activities of the patient. Typically, approximately eight to twenty weeks of bone ingrowth will be sufficient, before the first and second elements 20, 22 are uncoupled and permitted to articulate relative to one another. This temporary stabilisation of the first and second elements is accomplished by the present invention, without the requirement of a second surgical procedure, through the use of medium-term stabilising means formed from bioreabsorbable material. Examples of bioreabsorbable materials include polyglycolate polymers or analogues, lactides, polydioxanone, polyglyconate, lactide/glycolide copolymers. By appropriate selection of the material(s) of construction, the length of time required to biodegrade the stabilising means can be effectively controlled. After the stabilising means are dissolved and absorbed by the body, the first and second elements of the implant 10 are uncoupled, allowing articulation. In one example embodiment, depicted in Figure 3, the stabilising means can comprise one or more biodegradable shims 82 wedged between the first element 20 and the second element 22, to prevent relative motion therebetween. In another example embodiment, the first and second elements 20, 22 are placed in their coupled configuration, as shown in Figs. 2-3, with the spaces between the articulating surfaces 40, 42 then being injected or filled with a biodegradable polymer, which provides the medium term temporary stabilising means to couple the elements in position. Care will be taken to avoid filling the fusion chambers 30, 34 and the openings 32, 36 to the fusion chambers with the polymer, which could inhibit bone ingrowth. The threads 82 will also remain exposed to assist in implantation of the device. In another example embodiment, depicted in Figure 2, the stabilising means comprise a removable and/or bioreabsorbable endcap 90, which releasably engages the trailing end 92 of the implant 10 to couple the first and second elements 20, 22. The endcap can comprise one or more clips 94 for engaging the implant 10, and one or more keyways 96 for engaging a wrench, driver or other actuation device used to advance the implant 10 into the intervertebral space. A second removable and/or absorbable endcap can be installed on the leading end 93 of the implant 10. The endcaps may additionally function to retain the bone fragments within the chambers 62,72 of the fusion chambers 30, 34, as will be described in greater detail below, until sufficient bone ingrowth and fusion has occurred.

Another embodiment of the present invention is depicted by Figure 5, which shows an implant 10, generally comprising first and second elements 20, 22, substantially as described above, and further comprising an intermediate articulation element, which in the depicted embodiment comprises a generally hemispherical bowl-shaped cap 90 interposed between the concave surface 46 of the first element 20 and the convex surface 48 of the second element 22. The cap 90 is preferably fabricated from a wear-resistant, low friction material of construction, which may be somewhat resilient to absorb impact loading. The provision of the cap 90 allows articulation at the interface between the top surface of the cap and the concave surface 46 of the first element 20, and between the bottom surface of the cap and the convex surface 48 of the second element 22, resulting in a bipolar articulation. This arrangement reduces frictional wear on the articulation surfaces by distributing wear over two articulation interfaces. The engagement of the concave lower surface of the cap 90 with the convex

surface 48 of the second element 22, and the engagement of the convex upper surface of the cap 90 with the concave surface 46 of the first element 20, prevents the cap 90 from becoming dislodged when the implant 10 is installed.

The present invention further comprises a method of maintaining a desired intervertebral space 5 between a first vertebra 12 and a second vertebra 14. The method preferably comprises removing a section of the first vertebra to form a cavity therein, mounting a first element of an articulating spinal implant into the cavity, and connecting a second element of the implant to the second vertebra. The articulating spinal implant used to carry out this method is preferably substantially similar to the example embodiment described above, having first and second internal articulation surfaces which 10 adjoin to form a joint allowing relative pivotal movement between the first and second elements, but preventing relative axial compression therebetween. At least one of the elements preferably further comprises a fusion chamber, including a chamber and at least one opening communicating with the chamber, for facilitating bone ingrowth into, through and around the fusion chamber from the respective vertebra. In a preferred form, the method of the present invention comprises attachment of 15 both the first and second elements of the implant to the respective vertebra using fusion chambers for bone ingrowth. In this embodiment, a section of the second vertebra is preferably removed to form a cavity therein for receiving the second element of the implant. The method of the present invention can further comprise the insertion of bone fragments, which may be the fragments formed in the above-described removal of vertebral sections, into the fusion chamber(s) of the implant. The 20 presence of these bone fragments has been shown to stimulate and enhance bone ingrowth into the fusion chamber. In another embodiment, the method of the present invention anticipates the application of means for stimulating bone growth into, through, and/or around the fusion chamber(s). The means for stimulating bone growth can comprise, for example, electrical or magnetic bone growth stimulators, bone morphogenetic protein (BMP), hydroxyl apatite compounds, demineralised bone 25 compound, and/or other bone growth stimulating devices or compounds. It is also anticipated that the introduction of a cyanoacrylate material, commonly referred to as surgical glue, onto the outer surface of the fusion chamber(s) may be used to fix the implant in optimal position awaiting bone ingrowth.

Implantation of the articulating spinal implant according to the present invention may be carried out in a manner generally similar to previously-known methods for the implantation of non-articulating, 30 rigid-fusion implants, with exceptions as set out herein. For example, the method of the present invention may utilise standard surgical approaches to the spine from either an anterior approach for the cervical and thoracic spinal segments, or from an anterior or posterior approach to the lumbar spinal segments. The removal of vertebral sections may be accomplished by drilling or chipping a generally circular bore having a diameter and depth adapted to generally match the implant to be 35 utilised, bridging the first and second vertebra. Additionally, the circular bore may be tapered with the leading end diameter being smaller than the tail end diameter. The bore is preferably centred over the intervertebral space, approximately midway between the first and second vertebra. Threads may then be tapped into the bore to facilitate insertion of the implant.

In an alternative method, the removal of vertebral sections may be accomplished by using an 40 unique surgical instrument, as shown in Figure 14, for drilling an elliptical bore having a major and

minor diameter and depth adapted to generally match the implant to be utilised, bridging the first and second vertebra. Preferably, the surgical instrument is affixed to a drill to provide rotational power to the cutting portion. The cutting portion of the surgical instrument consists of a circular flute drill bit sheathed within cutting blades formed in an elliptical shape. The flute drill bit extends out beyond cutting blades to cut a circular section between the first and second vertebra. As the drill bit cuts into the vertebra the cutting blades then remove the remaining material to form an elliptical bore having a major and minor diameter and depth adapted to generally match the implant to be utilised, bridging the first and second vertebra.

Alternatively, the implant can be provided with self-tapping threads. The implant is assembled with the first and second articulating surfaces engaged, and the first and second elements of the implant are rigidly coupled by stabilising means substantially as described above. The stabilised implant is advanced into the bore to the desired depth. Preferably, the implant is advanced until the tailing end 92 is flush or slightly recessed relative to the outer surface of the vertebrae, thereby eliminating the possibility that outwardly projecting portions of the implant may interfere with or injure adjacent or regional vascular, neural or visceral structures.

In the lumbar area, where greater load bearing is required, two articulating implants can be placed in parallel positions with the lengthwise axis of each adjacent one to the other, in a generally parallel arrangement, allowing flexion/extension movement alone. This arrangement will typically require removal of vertebral material to form two openings, or an extended opening to accommodate both implants. Alternatively, a single, appropriately sized implant could be placed in the interspace utilising the transabdominal open surgical approach, the transabdominal laparoscopic approach, or the retroperitoneal open anterior approach allowing pivotal motion around the single point of articulation as described above for use in cervical and thoracic intervertebral disc spaces.

Post-operatively, bone ingrowth will occur, fusing the first and/or second elements of the implant to the respective vertebra. After sufficient passage of time, the stabilising means is dissolved and absorbed into the body, uncoupling the articulation means to permit relative motion between the first and second elements, thus preserving spinal flexibility and minimising destructive stress upon adjacent intervertebral joints. The implant resists axial compression between the first and second elements, and thereby prevents relative compression between the first and second vertebra, thus maintaining the desired intervertebral space. Further, the implant is recessed into the recipient vertebral site, eliminating impingement on next adjacent vascular, neural or visceral structures.

While the invention has been disclosed in its preferred forms, it will be apparent to those skilled in the art that many modifications, additions, and deletions can be made therein without departing from the spirit and scope of the invention and its equivalents as set forth in the following claims.

The claims defining the invention are as follows:

1. A spinal implant comprising: a first element comprising a first articulation surface and a first threaded outer surface adapted to engage a first vertebra; a second element comprising a second articulation surface and a second threaded outer surface adapted to engage a second vertebra; and
5 wherein said first and second articulation surfaces cooperate to allow relative movement between said first and second elements.
2. The spinal implant of claim 1, wherein said first and second threaded outer surfaces cooperate to form a generally cylindrical implant body.
3. The spinal implant of claim 1, wherein said first and second threaded outer surfaces
10 cooperate to form a generally conical implant body.
4. The spinal implant of claim 1, 2 or 3 wherein said first and second threaded outer surfaces cooperate to form a substantially continuous threaded outer surface to facilitate threading advancement of the implant between the first and second vertebra.
5. The spinal implant of claim 4, wherein said substantially continuous threaded outer
15 surface is self-cutting.
6. The spinal implant of any one of claims 1 to 5, wherein said first articulation surface abuts said second articulation surface to form an articulation means.
7. The spinal implant of any one of claims 1 to 6, wherein one of said first and second articulation surfaces defines a convex portion and the other of said first and second articulation
20 surfaces defines a concave portion, at least a portion of said convex portion being engaged within said concave portion to allow said relative movement between said first and said second elements.
8. The spinal implant of any one of claims 1 to 7, wherein one of said first and second articulation surfaces defines a rocker and the other of said first and second articulation surfaces defines a channel, at least a portion of said rocker being engaged within said channel to allow said
25 relative movement between said first and said second elements.
9. The spinal implant of any one of claims 1 to 8, further comprising a stabilising element for temporarily engaging said first element with said second element.
10. The spinal implant of any one of claims 1 to 9, wherein at least one of said first and second elements includes: a fusion chamber; and at least one opening extending through said outer
30 surface and in communication with said fusion chamber to allow bone ingrowth into said fusion chamber.
11. A spinal implant, comprising:
a first element comprising a first articulation surface and a first outer surface defining a first convex lateral curvature extending substantially entirely across a width of the implant and adapted to
35 engage a first vertebra;
a second element comprising a second articulation surface and a second outer surface defining a second convex lateral curvature extending substantially entirely across said width of the implant and

adapted to engage a second vertebra; and wherein said first and second articulation surfaces cooperate to allow relative movement between said first and second elements.

12. The spinal implant of claim 11, wherein said first and second convex lateral curvatures cooperate to form a generally cylindrical implant body.

5 13. The spinal implant of claim 11, wherein said first and second convex lateral curvatures cooperate to form a generally elliptical implant body.

14. The spinal implant of claim 11, wherein said first and second convex lateral curvatures cooperate to form a generally conical implant body.

10 15. The spinal implant of any one of claims 11 to 14, wherein said first and second outer surfaces are threaded and cooperate to form a substantially continuous threaded outer surface to facilitate threading advancement of the implant between the first and second vertebra.

16. The spinal implant of any one of claims 11 to 15, wherein one of said first and second articulation surfaces defines a convex portion and the other of said first and second articulation surfaces defines a concave portion, at least a portion of said convex portion being engaged within
15 said concave portion to allow said relative movement between said first and said second elements.

17. The spinal implant of any one of claims 11 to 16, wherein one of said first and second articulation surfaces defines a rocker and the other of said first and second articulation surfaces defines a channel, at least a portion of said rocker being engaged within said channel to allow said relative movement between said first and said second elements.

20 18. The spinal implant of any one of claims 11 to 17, wherein at least one of said first and second elements includes: a fusion chamber and least one opening extending through said outer surface and in communication with said fusion chamber to allow bone ingrowth into said fusion chamber.

19. The spinal implant of any one of claims 11 to 18, further comprising a stabilising element
25 for temporarily coupling said first element to said second element.

20. A spinal implant, comprising:

a first element comprising a first articulation surface and a first outer surface adapted to engage
a first vertebra;

30 a second element comprising a second articulation surface and a second outer surface adapted to engage a second vertebra; and

wherein one of said first and second articulation surfaces defines an elongate rocker and the other of said first and second articulation surfaces defines an elongate channel, at least a portion of said rocker being engaged within said channel to allow relative movement between said first and said second elements.

35 21. The spinal implant of claim 20, wherein said channel has a varying channel width.

22. The spinal implant of claim 21, wherein said channel width varies along a depth of said channel.

23. The spinal implant of claim 21 or 22, wherein said channel width varies along a length of said channel.

24. The spinal implant of any one of claims 20 to 23, wherein said channel has an hour-glass shape.

5 25. The spinal implant of claim 24, wherein said rocker has an hour-glass shape.

26. The spinal implant of any one of claims 20 to 25, wherein said rocker has a varying rocker width.

10 27. The spinal implant of any one of claims 20 to 26, wherein said first and second outer surfaces are threaded and cooperate to form a substantially continuous threaded outer surface to facilitate threading advancement of the implant between the first and second vertebra.

28. The spinal implant of any one of claims 20 to 27, wherein said first outer surface defines a first convex lateral curvature adapted to engage the first vertebra, said second outer surface defining a second convex lateral curvature adapted to engage the second vertebra.

15 29. The spinal implant of any one of claims 20 to 28, further comprising a stabilising element for temporarily engaging said first element with said second element.

30. A spinal implant, comprising: a first element having a first outer surface adapted to engage a first vertebra; a second element having a second outer surface adapted to engage a second vertebra; and a stabilisation element adapted to temporarily stabilise said first and second elements to facilitate fusion with the first and second vertebra.

20 31. The spinal implant of claim 30, wherein said stabilisation element is formed of a bioabsorbable material adapted to be absorbed subsequent to implantation.

32. The spinal implant of claim 30 or 31, wherein said stabilisation element is formed of a biodegradable material adapted to degrade subsequent to implantation.

33. The spinal implant of claim 31 or 32, wherein said material is a polymeric material.

25 34. The spinal implant of claim 31, 32 or 33, wherein said material is selected from a group consisting of polyglycolate polymers, polyglycolate analogues, lactides, polydioxanone, polyglyconate, lactide copolymers, and glycolide copolymers.

30 35. The spinal implant of any one of claims 30 to 34, wherein said stabilisation element comprises an endcap adapted to releasably engage a portion of said first element and a portion of said second element.

36. The spinal implant of any one of claims 30 to 35, wherein said first element includes a first articulation surface, said second element including a second articulation surface, said first and second articulation surfaces cooperating to allow relative movement between said first and second elements.

35 37. A method of maintaining an intervertebral space between a first vertebra and a second vertebra, comprising:

providing a spinal implant having a first element and a second element, the first element having a first articulation surface and a first threaded outer surface, the second element having a second articulation surface and a second threaded outer surface;

engaging the first threaded outer surface of the first element against a portion of the first vertebra;

engaging the second threaded outer surface of the second element against a portion of the second vertebra; and

adjoining the first and second articulation surfaces to permit relative movement between the first and second elements.

38. The method of claim 37, wherein the engaging comprises threadingly advancing the spinal implant between the first vertebra and the second vertebra.

39. The method of claim 37 or 38, further comprising temporarily coupling the first element to the second element prior to the engaging.

40. The method of any one of claims 37 to 39, wherein each of the first and second elements includes a fusion chamber and at least one opening extending through the convex outer surface and in communication with the fusion chamber; and the method further comprising inserting a bone growth promotion substance into the fusion chamber to facilitate both ingrowth.

41. A spinal implant, substantially as hereinbefore described with reference to the accompanying drawings.

42. A method of maintaining an intervertebral space between a first vertebra and a second vertebra, said method being substantially as hereinbefore described with reference to the accompanying drawings.

43. A spinal implant according to any one of claims 1 to 36 or 41 when used for maintaining an intervertebral space between a first vertebra and a second vertebra.

Dated 25 August 2004
SGDI HOLDINGS, INC

Patent Attorneys for the Applicant/Nominated Person
SPRUSON & FERGUSON

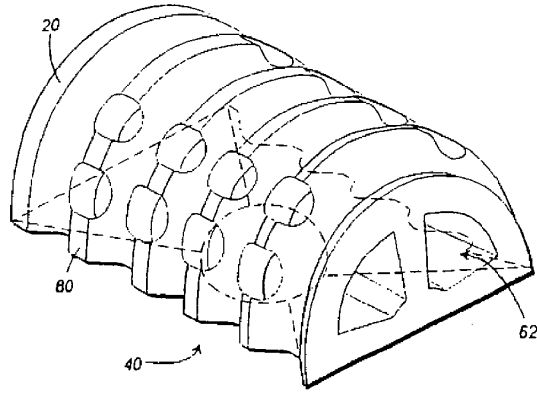

FIG. 1A

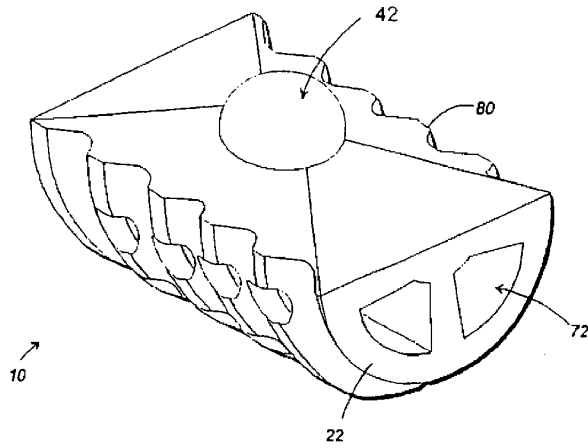

FIG. 1B

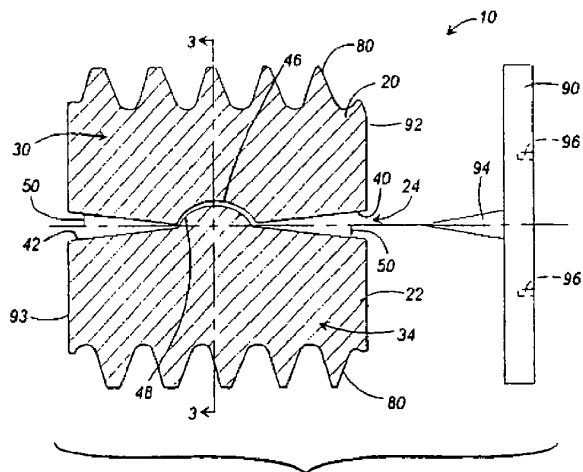

FIG. 2

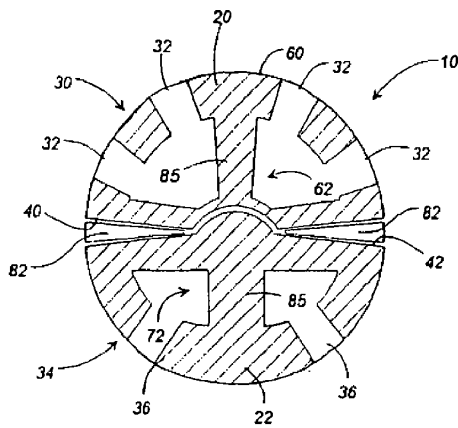

FIG. 3

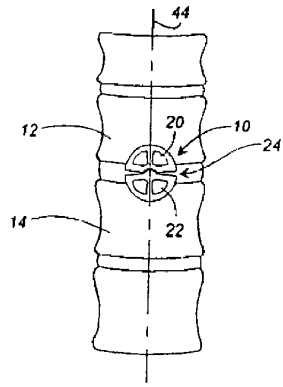

FIG. 4A

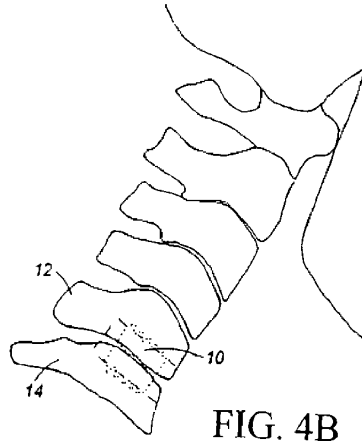

FIG. 4B

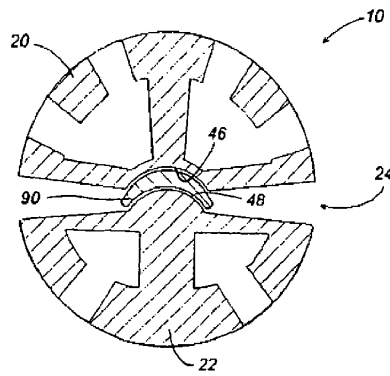

FIG. 5

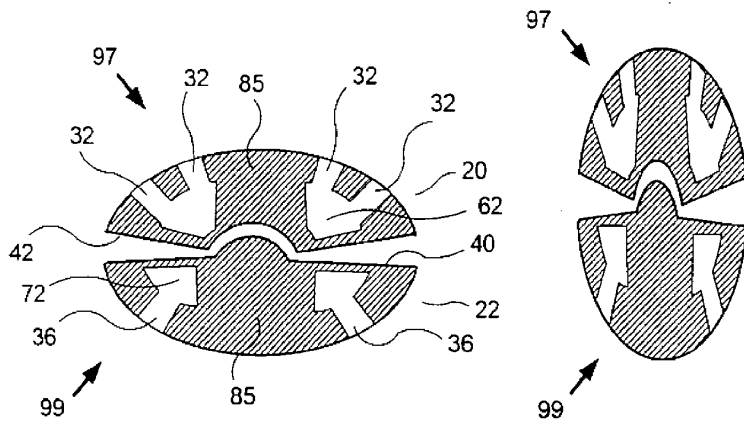

FIG. 6A

FIG. 6B

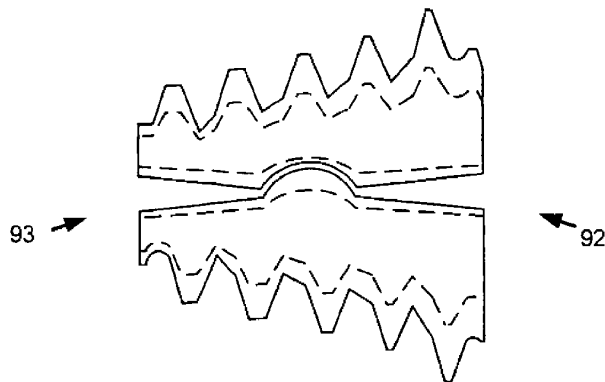

FIG. 7

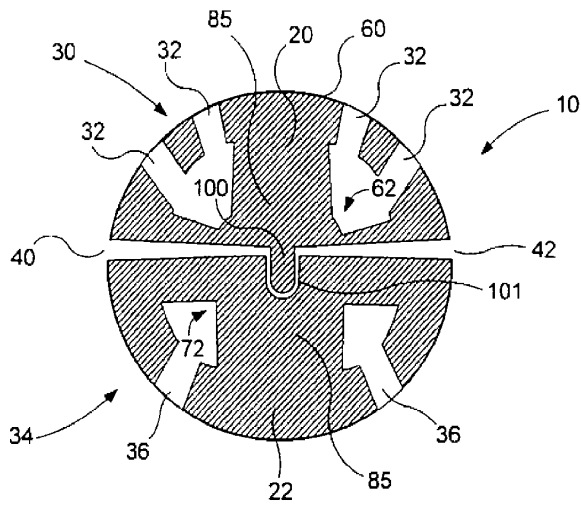

FIG. 8

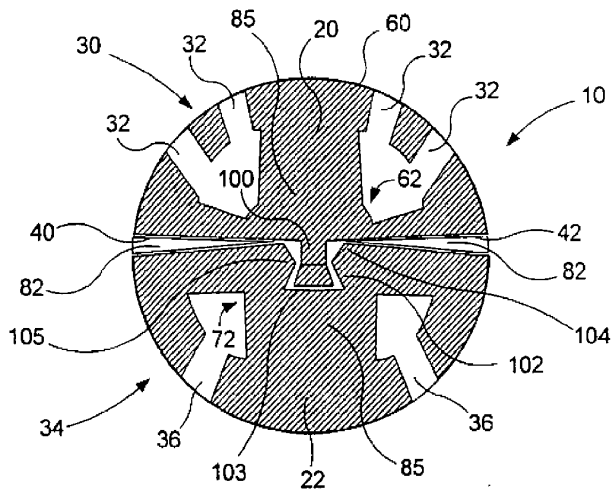
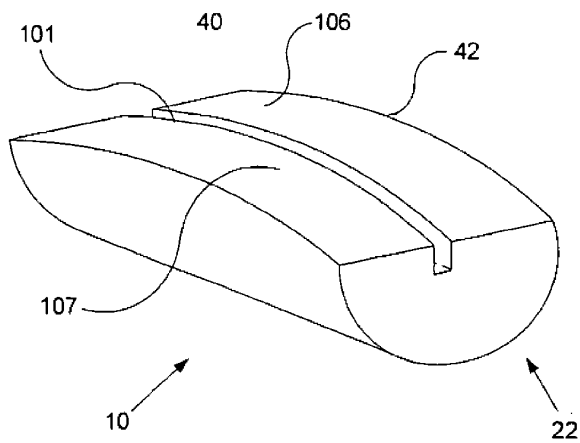
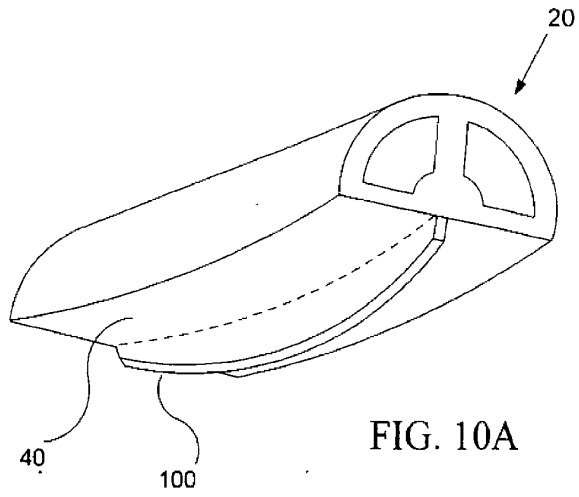

FIG. 9



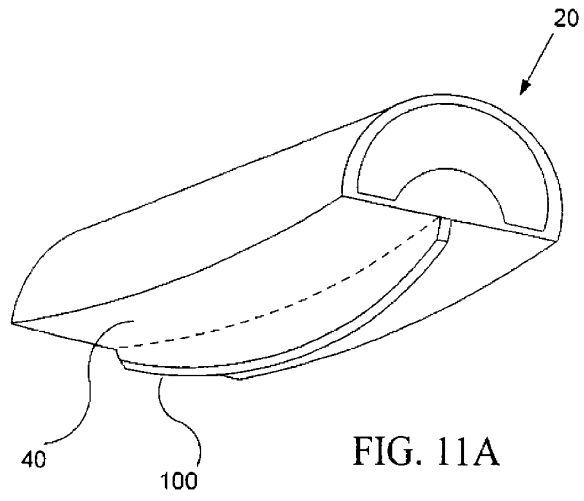

FIG. 11A

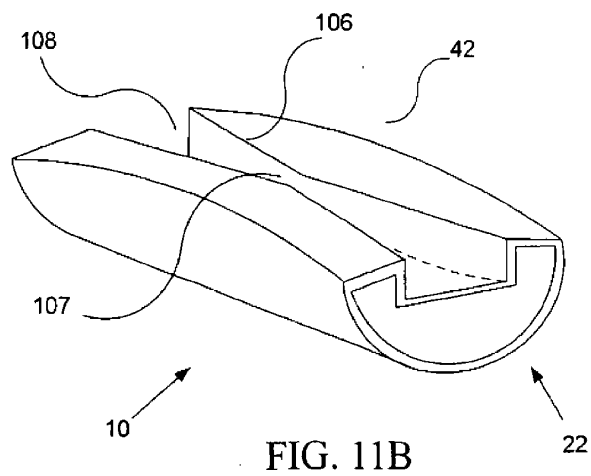

FIG. 11B

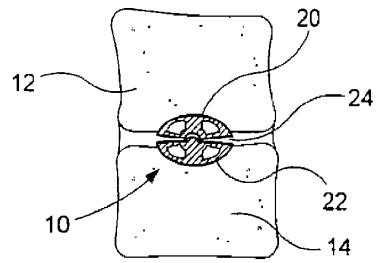

FIG. 12

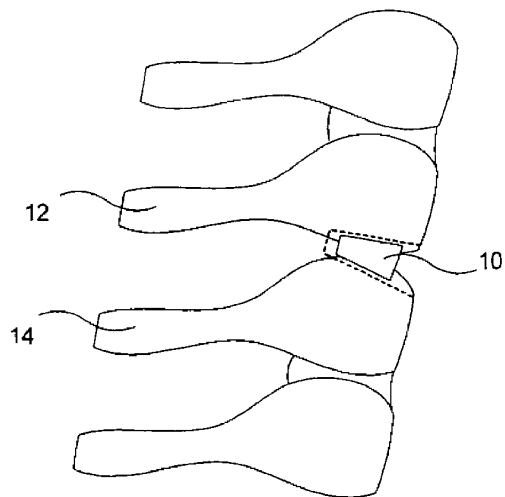

FIG. 13

9/9



FIG. 14A

FIG. 14B

