

*L. D. Phillips.*  
*Diving Armor.*

*N<sup>o</sup> 15,898.*

*Patented Oct. 14, 1856.*

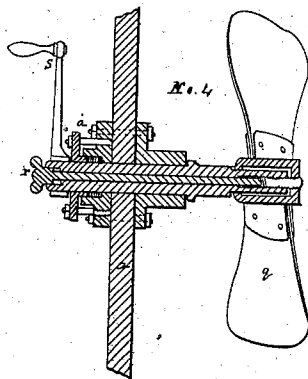
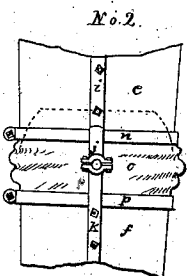
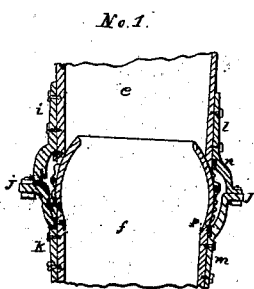

*Fig. 3. Section.*

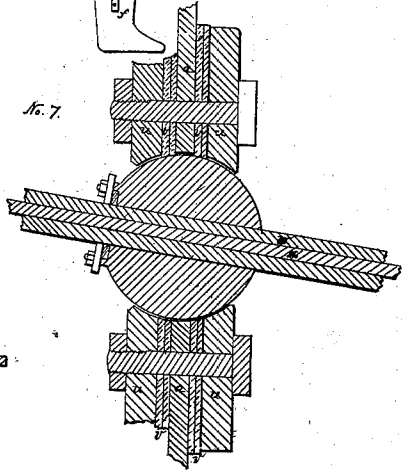
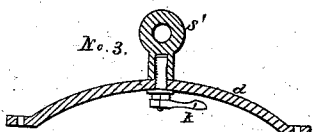
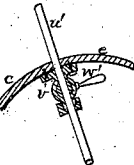
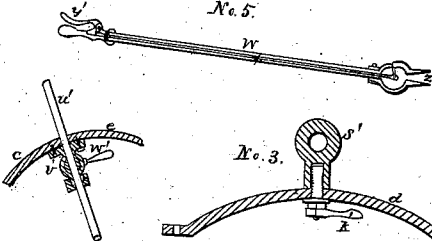
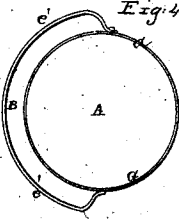
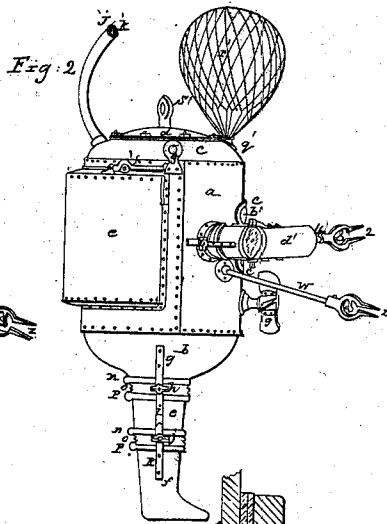
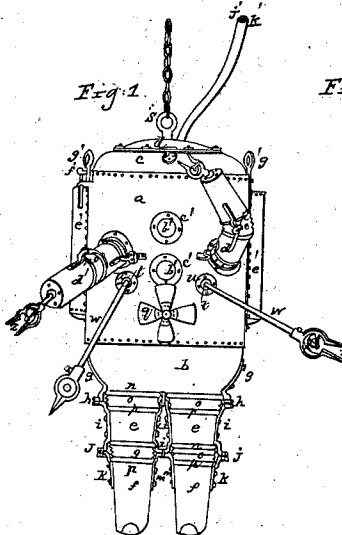
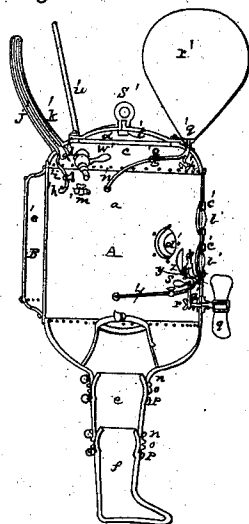

# UNITED STATES PATENT OFFICE.

L. D. PHILLIPS, OF CHICAGO, ILLINOIS.

## SUBMARINE EXPLORING-ARMOR.

Specification of Letters Patent No. 15,898, dated October 14, 1856.

*To all whom it may concern:*

Be it known that I, LODNER D. PHILLIPS, of the city of Chicago, in the county of Cook and State of Illinois, have invented certain new and useful Improvements in Submarine Armor or Exploring Apparatus; and I do hereby declare that the following is a full, clear, and exact description thereof, reference being had to the accompanying drawings, and to the letters of reference marked thereon and forming part of this specification, in which—

Figure 1 represents a front view of the apparatus; Fig. 2, a side view of the same; Fig. 3, an upright section; Fig. 4, a horizontal section, with several other sectional views and parts of the apparatus which will be more particularly named hereafter.

In general my invention relates to the construction of a metallic vessel or apparatus so apportioned, arranged and equipped with tools or instruments for sub-marine explorations, and of proper form to admit a man in its principal cavity, and in furnishing such metallic casing with air chambers and other apparatus for the convenience and safety of the person operating the same; also suitable joints of peculiar construction to allow the free use of the legs and arms of the operator; also attachments by means of which the operator can ascend, or descend, or change his position and give locomotion to the machine without assistance from others.

*a*, represents a cylinder of boiler iron having the dome head *c*, of cast iron, furnished with a "manhole" which is covered with the cap *d*. This cap is bolted to the head, having a gasket of leather or india rubber in the joint. The lower end of the cylinder *a*, is fitted with a cast iron concave bottom as shown at *b*. There are two circular openings in this bottom, cast with flanges to receive the legs of the machine.

*e*, represents the upper and *f* the lower part of the legs.

The joints at the hips and knee are constructed on the "ball and socket" principle, as shown at Nos. 1 and 2.

The legs *e*, *f*, are of cast iron, and are suspended from the bottom *b*, by the iron straps *g*, *i*, and *h* on the outside and by the straps *l* and *m* on the inside. The up-

per ends of the lower straps have journals, or pivots, fitted in boxes formed in the lower end of the upper straps. These joints are shown at *h* and *j*. An iron stud or pillow block is attached to the bottom *b*, between the legs, in which the pivots of the upper ends of the straps *i*, are fitted. These pivots are concentrated with and form the axis of the socket joints. To prevent the passage of water through these socket joints I envelop them with a ring of india rubber or other suitable elastic substance, as shown at *o*. The edge of this elastic ring is secured above and below the joint by the hoops *n* and *p*. These hoops have their ends flanged and are drawn tight with a screw bolt in the usual manner.

*e'* is an exterior casing also of boiler iron placed at the back of the cylinder *a*, at a distance from it, and concentric to it. This casing *e'*, forms a chamber, as shown on Fig. 3 and at B on Fig. 4. This chamber is for the purpose of containing air forced into it, to any desired degree of density, and forms a reservoir upon which the operator may draw as required.

*j'* and *k'* are two elastic tubes inclosed in a circumscribing tube, of any desired length. The tube *j'*, is connected by the small pipe *h'*, to the side of the cylinder *a*, and opens into the air chamber B. The upper end of the tube *j'*, connects with an air forcing pump. A cock *i'*, is inserted in the connecting tube *h'*. The pipe *k'*, opens into the principal cavity, and is the escape pipe for the vitiated air, a valve being fitted to the inner end of the pipe, and is opened by the operator as occasion may require. Signals are also made through this pipe by means of the voice or discharges of air.

*m'*, represents a cock by means of which the air is admitted from the air chamber into the principal cavity A.

*b'*, *b'*, are two glass plano-convex lenses inserted in the cylinder *a*, and secured by the rings *c'*, *c'*. A lamp, as shown at *y*, is placed inside and near the lower lens. This lamp is furnished with a concave reflector, as shown at *z'*. The upper lens acts as a window, through which the operators may observe the objects sought, aided by the light emitted through the lower lens by the lamp. A small pipe *w'*, communicates with

the chamber B, and conducts a sufficient supply of air to the lamp, where it is properly distributed to feed the flame. A cock is placed in this pipe to regulate this supply or cut it off as desired.

5  $d'$ , represents two arms, constructed with two socket joints each, on same principle as joints in legs before described, except that the axis at the shoulders is horizontal, and  
10 the axis at the elbow is vertical.

$q$ , is a small spiral fan wheel attached to the front of the cylinder  $a$ , and made to rotate by the crank  $s$ . The axis of this wheel passes through proper stuffing boxes,  
15 as shown at  $a'$ . This axis is hollow and fitted with a spindle, as shown at  $r$ . By means of this spindle  $r$ , the operator can disengage the fan wheel  $q$ , and let it drop from the machine should occasion require it.

20 An enlarged section of this wheel is shown at No. 4.

$f'$ , represents a safety valve placed on top of air chamber B, the valve being retained on its seat by means of a lever and spiral  
25 spring in the usual manner.

$g'$ ,  $g'$ , represent two eyes attached to the apparatus, to which ropes or chains may be attached for the purpose of handling the machine.

30  $s'$ , represents the principal suspension eye bolt which is made with a female screw-cavity, into which is fitted the screw bolt, and attached to the cap  $d$ , as shown on Fig. 3 and enlarged at No. 3. The operator can  
35 detach this bolt by means of the handle  $t'$ .

$q'$ , represents a neck of metal attached to the head  $c$ . I thus attach to this neck a balloon shaped bag of india rubber, or other suitable elastic substance, as shown at  
40  $v'$ . The bag  $v'$ , is inclosed in a net of cords, which are attached to the neck  $q'$  on head  $c$ . A small hole is made through the neck  $q'$ , and a small pipe  $n'$  connects it with the air chamber B. A stop cock is fitted in this  
45 tube at  $o'$ . A branch of this pipe also fitted with a cock opens into the principal cavity A.

$w'$ , represents a small metallic tube of indefinite length, which the operator carries with him in the machine, and on reaching  
50 the surface of the water he may insert the tube through the valve  $v'$ , as shown at No. 5, the valve being moved by the handle  $w'$ , the tube extending upward above any  
55 surging or splashing of water. The operator by applying his mouth to the tube may inhale air from above the surface of the water.

A leathern girdle is buckled around the  
60 loins of the operator, and is attached by two straps to the inner surface of the bottom  $v$ , for the purpose of firmly attaching the operator to the machine and to facilitate the motions which he may wish to impart to the legs or body of the apparatus.  
65

No. 6, represents in section one of the tools used in operating with this machine.  $w$ , is a smooth metallic hollow bar having its outer end formed in movable tongs, as shown at  $z$ , the upper jaw of the tongs being moved by the hand lever  $y'$ , and rod  $x$ ,  
70 passing out through the cavity in the bar  $w$ , as shown on the drawings. The bar  $w$ , passes through the socket ball  $t$ , as shown in section enlarged at No. 7, where  $v$ ,  $v$ , represent a packing of leather held by the  
75 metallic rings  $u$ ,  $u$ , secured by bolts and forming a socket in which the ball can move in any direction. A saw, or an augur, or other implement may be placed in the  
80 jaws of the tongs and such motion be given it as may be required by the operator. The ends of the arms  $d'$ , are fitted with balls and sockets, as represented at No. 7.

The operation of this machine is such  
85 that a person placing his feet in the lower extremities  $f$ ,  $f$ , of the machine and attaching the leathern girdle firmly about his loins, the air chamber  $e'$ , being filled with condensed air, the cap  $d$ , firmly bolted to  
90 the head  $c$ , the apparatus may be let down to any required depth in water. The operator experiences no additional pressure than when exposed to the common atmosphere. The air in the cavity A, becoming  
95 vitiated he turns the cock  $m'$ , and receives a fresh supply from the air pressed in the reservoir B. The operator opens the valve  $v'$ , and allows the vitiated air to escape through the tube  $k'$ . If the operator wishes  
100 to ascend without assistance he turns the cock  $o'$ , and admits the compressed air into the bag or sub-marine balloon  $r'$ , which by displacing the water gives additional buoyancy to the apparatus; then if wishing to  
105 descend again he closes the cock  $o'$ , and opens the cock  $p'$ , in the branch pipe, and the pressure of the water gently collapses the balloon  $r'$ . The air passing into the  
110 cavity A, supplies the operator with fresh air instead of drawing direct from the air chamber.

The advantages of this machine over all others are, first, the operator is freed from  
115 all pressure of water at any depth; secondly, he has ample locomotive control over the apparatus; thirdly, he can ascend to the surface on his own account and without the assistance of others.

I construct the bolts of cap  $d$ , so that the cap may be loosened and removed by the operator from the inside.  
120

Having thus fully described the construction and operation of my invention what I claim therein as new and for which  
125 I desire to obtain Letters Patent is—

1. A sub-marine armor with which the explorer can be wholly invested, composed  
130 entirely of metal, having free and easily moving jointed limbs, and from within

which the explorer may give motion to the armor and operate the external means as set forth in this specification.

5 2. Connecting with such armor a collapsible exterior vessel so united with the interior air chamber as to allow of its being inflated and buoy up the armor as described.

3. Arranging the rods for operating the external tongs or nippers within the tubular arms as set forth. 10

L. D. PHILLIPS.

Attest:

JOHN S. HOLLINGSHEAD,  
H. PELLSON.