

M. G. BUNNELL.
 MEASURING AND DISPENSING MACHINE.
 APPLICATION FILED JULY 13, 1917.

1,291,759.

Patented Jan. 21, 1919.

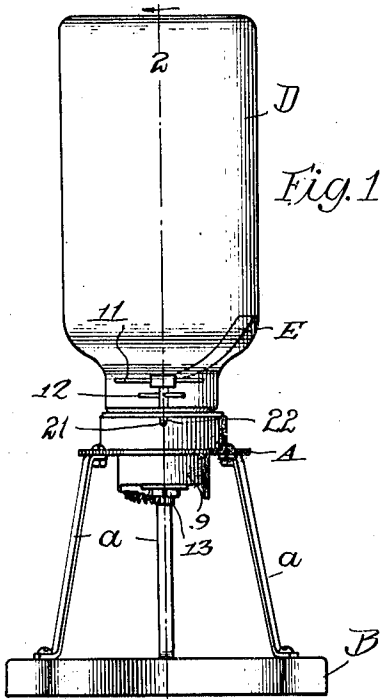

Fig. 1

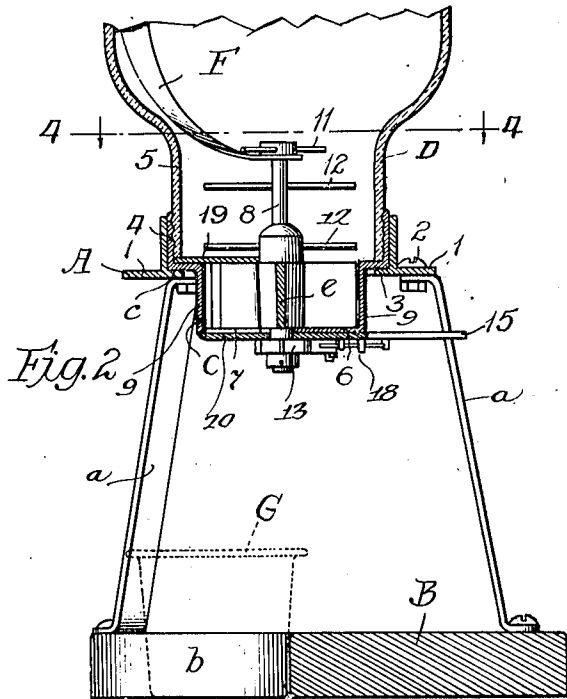

Fig. 2

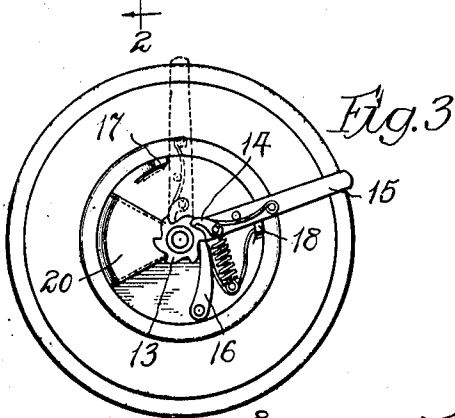

Fig. 3

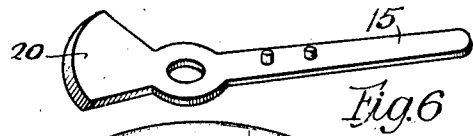

Fig. 6

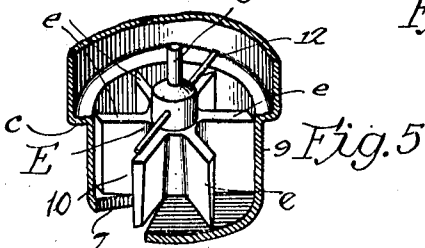

Fig. 5

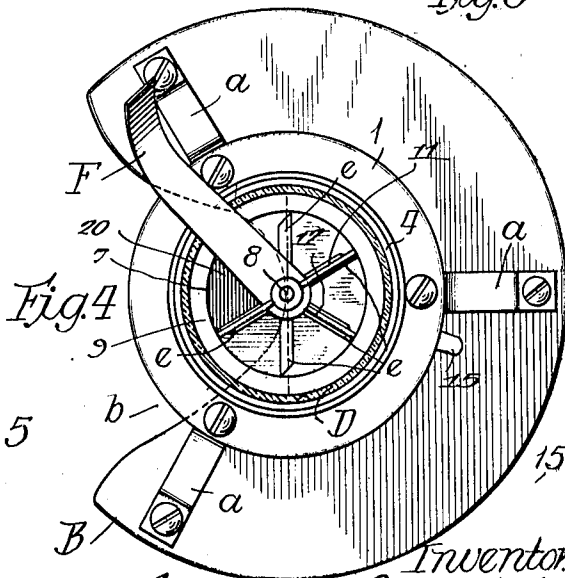

Fig. 4

Witness
 Chas. R. Kourshak

Inventor
 Morton G. Bunnell
 By: Arthur F. Duval, Atty.

UNITED STATES PATENT OFFICE.

MORTON G. BUNNELL, OF DECATUR, ILLINOIS, ASSIGNOR OF ONE-HALF TO JOHN A. HARRELL, OF DECATUR, ILLINOIS.

MEASURING AND DISPENSING MACHINE.

1,291,759.

Specification of Letters Patent.

Patented Jan. 21, 1919.

Application filed July 13, 1917. Serial No. 180,282.

To all whom it may concern:

Be it known that I, MORTON G. BUNNELL, a citizen of the United States of America, and resident of Decatur, Macon county, Illinois, have invented a certain new and useful Improvement in Measuring and Dispensing Machines, of which the following is a specification.

This invention relates to measuring and dispensing machines of that kind in which means are provided for feeding the contents of an inverted bottle or other container downward therefrom in measured quantities.

It will be seen that this is an improvement over the construction shown and described in application Serial No. 157,330, filed March 26, 1917, in which the invention is claimed broadly.

The objects of these improvements are, to provide means whereby the feed device may be attached to the bottle, or removed therefrom, while the bottle is right-side-up, and whereby the feed device is readily removable from the machine for that purpose; to provide means to scrape the interior of the bottle, thereby to loosen the contents thereof; to provide a valve which will automatically open and close the opening in the bottom of the feed device; to provide the feed device with blades which are tapered downward in cross-section, so that the spaces between the blades are larger at the bottom than at the top, and whereby the feed device will not become clogged; to provide a feed device in which the blades are beveled at the ends thereof, with the bevel of each blade on the rear side thereof, so that the materials will be less liable to accumulate within and to interfere with the proper operation of the feed device; to provide a base having a recess in which a cup may be placed to receive the materials from the feed device; and to provide certain details of construction tending to increase the general efficiency and desirability of a measuring and dispensing machine of this particular character.

To the foregoing and other useful ends, this invention consists in matters hereinafter set forth and claimed.

In the accompanying drawings:—

Figure 1 is a side elevation of a measuring and dispensing machine embodying the principles of this invention.

Fig. 2 is an enlarged vertical section of said machine, on line 2—2 in Fig. 1, with a

portion of the bottle broken away for convenience of illustration.

Fig. 3 is a bottom plan view of the feed device.

Fig. 4 is a plan of the structure shown in Fig. 2, with the bottle shown in horizontal section on line 4—4 in Fig. 2, and with the feed plate omitted to show the feed wheel below.

Fig. 5 is a perspective, partly in section of a portion of the feed device.

Fig. 6 is a perspective of a handle and valve which are mounted on the bottom of the feed device.

As thus illustrated, the invention comprises a ring or member A of annular form, mounted on legs *a*, which latter are supported upon a base B, so that the member A is supported in suitably elevated position. Said member A has an outer flange 1 to which the said legs are secured by bolts or screws 2, and has an inner flange 3 which forms a shoulder. The feed device comprises a hollow member C provided with a shoulder *c* to rest upon the flange 3, and formed with an upper screw-threaded portion 4 to receive the screw-threaded neck-portion 5 of the bottle D, which latter may be of any suitable form or character. Said member C has a bottom 6 provided with a feed opening 7, and contains a rotary feed-wheel E provided with blades *e*, said feed-wheel being mounted on a vertical shaft 8 which is mounted to rotate in the bottom of the member C, in any suitable manner, whereby the blades *e* scrape the bottom 6 and also the cylindrical sides 9 of said hollow member. The blades *e* preferably taper downward in cross-section, so that the spaces between the blades are larger at the bottom than at the top thereof, thereby to prevent the materials from clogging in the feed device. Also, the outer ends of said blades have beveled edges 10, the bevel of each blade being at the rear side thereof, whereby the blades scrape the cylindrical inner surface of the member C, and so that the materials will not be compressed by the ends of the blades against the said cylindrical inner surface of the chamber in which the feed-wheel rotates. The upper portion of the shaft 8 is provided with transverse rods or wires 11 and 12 which serve as agitators to stir the materials in the neck of the bottle, thereby to facilitate the feeding of the

materials downward from the bottle and through the feed device. Also, with a view to preventing the materials from bridging in the bottle, and from failing to feed downward, a thin flexible sheet-metal scraper F is secured to the upper end of the shaft 8, and is disposed in position to scrape the inner surface of the bottle at the sides thereof, thereby to insure proper feeding of the materials from the bottle through the operation of the feed device. The shaft 8 is rotated by a ratchet-wheel 13 secured to the lower end of the shaft and a dog or pawl 14 pivoted on the handle 15, which latter is suitably mounted to fulcrum on said shaft. A detent 16 is pivoted on the bottom of the member C, to engage said ratchet-wheel, and suitable springs are provided to control said detent and also the dog or pawl 14, whereby the vibration of the handle operates the ratchet in a manner that will be readily understood. Stops 17 and 18 on the bottom of the member C limit the swinging movement or vibration of the handle 15, so that for each vibration of the handle the ratchet is advanced one notch, and the feed-wheel E is turned one space forward. The plate 19 covers one-half of the feed-wheel, directly above the opening 7, whereby a wide feed opening is formed by this plate, so that the materials feed into the pockets of the feed-wheel and are then carried around and discharged through the opening 7, when the handle 15 is swung over to a position to engage the stop 17, it being understood that this carries the valve 20 out from under the opening 7 to permit the materials to discharge from the feed device. This valve 20 is preferably rigid with the handle 15, and with the arrangement shown the valve and the handle are disposed at opposite sides of the ratchet, so that when the handle is swung toward the stop 17 the valve 20 is swung toward the detent 16, thereby to open the bottom of the feed device and operate the feed-wheel by one and the same manual operation of the handle.

The machine can be used for any suitable or desired purpose. For example, it can be used for dispensing malted milk, at soda fountains, or for any similar purpose. Malted milk and other similar materials are often packed or tamped into the bottles, but with the provision of the scraper F this will not interfere with the proper discharge of the contents of the bottle. When the handle is against the stop 18, being yieldingly held in this position by spring means, the valve 20 is closed, and moisture is prevented from entering the feed device at the bottom thereof. The threaded portion 4 is preferably provided externally with a pin 21 to engage the notch 22 in the upper edge of the member A, thereby to prevent rotation of the member C in the member A when the feed

device is operated. To attach the feed device to a bottle, all that is necessary is to remove the usual screw-threaded cap from the bottle, and to then screw the member 6 onto the threaded neck of the bottle. Then the bottle is inverted and the feed device is inserted downward in the member A, in the manner shown in the drawings, and the pin 21 is brought into engagement with the notch 22, whereby the machine is then ready for use. When the bottle is empty, it is removed with the feed device, and the latter is unscrewed and placed on another or fresh bottle. The base B, it will be seen, is provided at one side thereof with a notch or recess *b* to receive the cup or glass G when it is desired to draw off a portion of the contents of the bottle. The base B is preferably heavy enough to hold the machine upright, and against tipping over, and with the provision of the notch or recess *b* the glass or cup will rest on the table or counter upon which the machine is placed.

What I claim as my invention is:—

1. A machine for dispensing powdered materials, such as malted milk, by discharging measured quantities from the original bottle in which the product is sold, comprising a cup having an upper internally threaded portion to receive the threaded neck of said bottle, so that the bottle will be supported upside down, with a shoulder extending around the bottom of said threaded portion, a plate formed to provide a feed opening and having its edges supported on said shoulder to be clamped thereon by the mouth of said bottle, the bottom of the cup having an outlet disposed out of register with said feed opening, a central shaft extending upward through said cup and into the neck of said bottle, a feed wheel mounted on said shaft to rotate in said cup below said plate and provided with blades forming pockets between them to feed measured quantities of the product from said feed opening to said outlet, means on said shaft for stirring the product in the neck of the bottle, a ratchet mechanism on the lower end of said shaft, below the cup, to intermittently rotate said shaft, a horizontally movable lever to operate said mechanism, means on the bottom of said cup to limit the lateral swing of said lever to insure the advancement of said pockets, one at a time, to feed the product, a spring to retract said lever to normal position, a ring to support said cup and from which the cup is removable upwardly with the bottle, so that the bottle is attachable while right side up, and means to support said ring in elevated position, with space below for a glass to receive the discharge after each operation.

2. In a machine for dispensing powdered materials, the combination of a structure as specified in claim 1, and a valve pivoted on

said shaft to control said outlet, said valve being rigid with said lever.

3. In a machine for dispensing powdered materials, the combination of a structure as specified in claim 1, and a flexible scraper on the upper end of said shaft, adapted to scrape the sides of said bottle, being flexible to permit insertion of the bottle in said cup and removal therefrom.

4. A machine for dispensing powdered materials, comprising a ring, means to support said ring in elevated position, a cup removably supported in said ring, so that the cup hangs below the ring and is removable upwardly therefrom, a bottle disposed upside down and having its neck screwed into said cup, feed mechanism in said cup to discharge measured quantities from said bottle, and means on the bottom of said cup to operate said mechanism.

5. A machine for dispensing powdered materials, comprising a cup, feed mechanism in said cup, a receptacle forming a hopper over said mechanism, a ratchet provided with a handle to operate said mechanism to discharge measured quantities from said

hopper, and a valve rigid with said handle to control the discharge.

6. A machine for dispensing powdered materials, comprising a cup, feed mechanism in said cup, a bottle disposed upside down and having its neck screwed into said cup, means to operate said mechanism to discharge measured quantities from said bottle, and a flexible scraper secured to the upper end of said feed mechanism, adapted to scrape the sides of the bottle, being flexible to permit insertion of the bottle in said cup and removal therefrom.

7. In a machine for dispensing powdered materials, a structure as specified in claim 1, the feed opening provided by said plate being of a size and shape to uncover only one half of said feed wheel, so that a plurality of said pockets receive powder at the same time, and said outlet being below the covered half of the feed wheel and being substantially the same in size as one of said pockets.

Signed by me at Decatur, Illinois, this 5th day of July, 1917.

MORTON G. BUNNELL.